

VOL. XXIX. No. 1

JANUARY 1944

MECCANO

MAGAZINE



Nº 2747

SMOKE AND STEAM

6^d

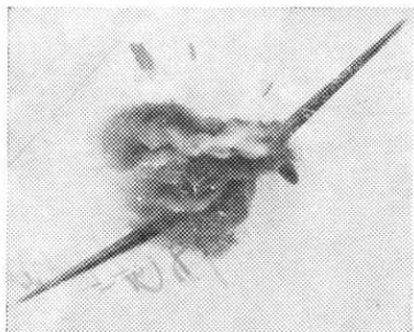

Destruction of a Heinkel III photographed from the attacking Spitfire by camera-gun. Such records are a small part of photography's great contribution to the War effort. Photography is mobilized for war, so don't blame your dealer if he says "Sold out of Selo!" Claims of the Services, Industry and Science come first. After victory, Selo films will be plentiful again, faster and better than ever. Till then our chief task must be **SERVICING THE WAR.**



FILMS made by **ILFORD LIMITED**
Ilford, London

ELITE

"AIRBORNE" GLIDER

Just the Model YOU Want

Span 42"

Contents of Kit: Dopes, Cement, Tissue, Strip, Wire, Sheet, CUT-OUT RIBS and Full Size Plan. **Price 11/1 Post Free**

SPITFIRES, HURRICANES, Etc., Etc.
Flying Models, from 5/4 Post Free

16-inch Span Flying Models from 2/- Post Free

SEND 3d. for **NEW CATALOGUE**
illustrating a **FULL RANGE** of **KITS**

ELITE MODEL AIRPLANE SUPPLIES
14, Bury New Road, MANCHESTER 8

*Here are more
U.S.A. RANKS!*



1. Officer's U.S.
2. 2nd Lieutenant.
3. 1st Lieutenant.
4. Captain. 5. Major.
6. Lieut.-Col. 7. Colonel.
8. General (one, two and three stars for Brig.-Gen., Maj.-Gen., and Lieut.-Gen.)

**HOW TO
RECOGNISE
OFFICERS
INSIGNIA**

**... and this is how you
can recognise Britain's
largest retailers of Cycles
and Cycle Accessories**

*Look for
the name*
HALFORDS

220 Branches in England,
Scotland and Wales. For the
best advice and service.
HALFORD CYCLE CO. LTD.
Head Office:
BIRMINGHAM

*There's a HALFORDS
in YOUR district*



THE MECCANO MAGAZINE



FROG

SCALE
MODEL
AIRCRAFT



TRADE MARK

REGD.

MADE IN ENGLAND BY
INTERNATIONAL MODEL AIRCRAFT LTD

For the sole Concessionaires

LINES BROTHERS LTD · TRI-ANG WORKS · MORDEN ROAD · MERTON · LONDON · S-W 19 · ENG

When this aim



turns to this



Webley

will be waiting

to supply sportsmen
the world over with
their celebrated
**WEBLEY AIR
RIFLES AND
PISTOLS**

Webley & Scott Ltd.
Birmingham
England
(Est. 150 years ago)



WORKING HARDER THAN EVER

To-day all our activities are being devoted to the supreme effort of victory. And Bassett-Lowke are proud of the part they are able to play in helping to hasten the day when you, a free man in a free country, can walk into any one of their branches and choose the best of everything in the model-making world, made by craftsmen who love their work.

Our London and Manchester branches are still open. We invite you to call on them. Our Wartime Staff will be pleased to give assistance and advice on any model matters.

Wartime Stock List (L/17) price 4d. post free.

BASSETT-LOWKE LTD.
NORTHAMPTON

LONDON: 112, High Holborn, W.C.1
MANCHESTER: 28, Corporation Street

BECK'S CHEMISTRY

Experiments at Home for Black-out Evenings

SPECIAL OFFER!

PARCEL OF USEFUL APPARATUS

with Booklet: "Experiments in Chemistry"

Post **10'6** Paid

Send stamped (1d.) addressed envelope for Price List of other equipment.

BECK (Scientific Dept. G), 60, High Street
STOKE NEWINGTON, LONDON N.16

During the National Emergency only limited supplies of

VITALITY BULBS

are now likely to be available.

If your Dealers cannot supply you with the type you require, do let us have full particulars, together with their name and address, because it might just happen that we know of factors who may be able to supply them.

VITALITY BULBS LTD.

NEVILLE HOUSE,
NEVILLE PLACE.

WOOD GREEN
LONDON, N.22

TRI-ANG

ALL BRITISH TOYS

LOOK OUT FOR THESE TRADE MARKS



TRADE MARK

International
Model Aircraft Ltd.

**FROG
MODEL
AIRCRAFT**



Lines Bros. Ltd.
TRI-ANG TOYS



Pedigree Soft Toys Ltd.
DOLLS

*Pedigree
Pets*

Pedigree Soft Toys Ltd.
**Hygienic
SOFT TOYS**



Unique & Unity
Cycle Co. Ltd.
**JUVENILE CYCLES
TRICYCLES
FAIRYCYCLES**

LINES BROS. LTD.

AND SUBSIDIARY COMPANIES
Unique & Unity Cycle Co. Ltd., Pedigree Soft Toys Ltd.
International Model Aircraft Ltd.

TRI-ANG WORKS, MORDEN ROAD, LONDON S.W.19

FREE! ANOTHER £10 IN CASH PRIZES FOR YOU

Here's your chance to win a prize! Read this spy story and fill in the missing words.

THE SPY-CLISTS. Very soon the spy came out, mounted a bicycle and rode away. There was very little —(1)—by then and it was difficult to keep far enough —(2)— to avoid being seen, yet never to lose sight of him. But the B.S.A. went like a bird, and the spy stopped at last at a lonely cottage on the common. When he was safely inside, Michael — (3)— to a window through which he could just see three men studying a plan. He crept closer to the window to see better, and a moment later heard the —(4)— of motor cycle engines coming rapidly nearer. After that things happened so fast that he was never very sure of the details. Several shots were fired but the spies were taken so completely by surprise that they put up no more than a feeble resistance, and it seemed only a few —(5)— before Sergeant Bailey was saying "Well, young man, we've certainly got to thank you and Monica—not to mention those splendid B.S.A. bikes of yours—for all this. It's hard luck on Monica," he added, "not being here to see the finish."

"I am here," cried Monica, arriving a little —(6)— but determined not to —(7)— all the excitement. "I couldn't quite keep up with your —(8)—cycles," she explained, jumping off her bike, "but it's marvellous what a —(9)— will do at a pinch!"
"It certainly is!" Sergeant Bailey agreed, admiringly.

All you have to do is to supply the 9 words which have been left out of the story. Write each one against the proper number in spaces provided on this form. Fill in your name, address, and date of birth, cut out, paste on the back of a postcard (Postage 2d.) and post to B.S.A. Cycles Ltd., Missing Word Competition, Dept. M.6, Small Heath, Birmingham 11, to be received not later than Feb. 12th, 1944. There are 3 prizes of £5, £3 and £2 for the best and most apt sets of answers. If two or more entrants tie for any one or more prizes, the prize or prizes will be divided equally between those entrants. Not more than one solution may be submitted by an entrant. The competition is limited to boys and girls under the age of 15 on the 1st January, 1944. The decision of B.S.A. Cycles Ltd. is final and no correspondence can be entered into. Names of winners will be published later in this paper.



ENTRY FORM No 6

Name.....

Address.....

Date of Birth.....

And don't forget to get your parents to put your splendid new B.S.A. Bicycle on order for you. They're scarce because of wartime, but you'll get your B.S.A.—if you're patient.

BSA THE BICYCLE
YOU CAN'T BEAT

(M.6)

1
2
3
4
5
6
7
8
9

A HAPPY NEW YEAR TO EVERY READER—The Editor

MECCANO

MAGAZINE

Editorial Office:
Binns Road
Liverpool 13
England

Vol. XXIX
No. 1
January 1944

With the Editor

Victory in Sight

Last January I ventured to say there was every reason to hope that the end of the year would bring within sight the end of the war, and events have shown that I was right. The wonderful agreement reached by Churchill, Roosevelt and Stalin at Teheran means that this year the Allied forces will attack with a concentrated power that Germany cannot withstand. The Nazis are doomed and there are plenty of signs that they know it.

This will be a year of terrible sacrifice, but it will be the year of victory.

Stainless Steel

A Sheffield Reply to C. G. Grey

I fully expected that C. G. Grey's article "*Those Wonderful Sword Blades*," in last month's "*M.M.*," would stir up something in Sheffield, and so it has proved. I print below an interesting letter I have received from Mr. E. N. Simons, joint author with Dr. E. Gregory of the splendid "*Simply Explained*" series of books on steel and its manufacture.

DEAR SIR,

Referring to the article "*Those Wonderful Sword Blades*," by C. G. Grey, in your last month's issue, we have read with interest the various points made by Mr. Grey.

We should like to take exception to his statement that stainless or rustless steel will not hold a razor edge. This is one of those "legends" to which Mr. Grey refers in an earlier paragraph. Some time ago, at a conference, I met exactly the same legend, and was able to demonstrate, both in description and in practice, that the legend had no foundation in fact. The legend arose in this way. When stainless steel was first produced, the cutlers knew next to nothing about it. They accordingly treated it pretty much in the same way as they treated the steels to which they were accustomed, and in consequence, a large number of inadequately hardened blades were put on the market. There was a rush by the market to buy these novel stainless knives, but they soon found that the edge went, and ever since, the story has gone round that stainless steel knives will not cut. Actually in

my possession is a stainless steel carving-knife, which is the equal of any ordinary steel knife, and which has already been used for about 20 years. The only type of steel that might excel it is genuine double shear steel, and as far as I know, there is only one firm making this steel at the present time—Messrs. Edgar Allen and Co. Ltd. Even users of modern, properly heat treated and hardened stainless steel knives do still complain that the knives are not so sharp as ordinary knives. On investigation, one finds that, whereas the old carbon steel knife was always put through a sharpening machine, or sharpened on a stone, the stainless steel knife is seldom or never sharpened, with the result that, after a time, the edge becomes blunted, and naturally will not cut so well as that of a sharpened knife. If users take the same trouble to keep their stainless knives sharp as they do to keep ordinary knives sharp, there will be no complaint whatsoever.

Actually, it can be proved that a stainless steel knife by virtue of its composition and treatment must be harder and keener than an ordinary carbon steel knife, with the solitary exception indicated.

It should also be noted that there are still firms who will not give to the steel the correct treatment, either through ignorance, idleness, or false economy. Probably the knife to which your contributor refers came in this category.

The last paragraph of your contributor's article is a statement that, while true of some products, is certainly not true of others, and if only we had time and opportunity, we could provide the evidence that would refute it.

Yours, etc.,

EDGAR ALLEN & CO. LTD.

(Signed) ERIC N. SIMONS,
Publicity Manager.

Any comments, readers?

This Month's Special Articles

	Page
P. R. U.—I, by C. G. Grey	.. 2
From "Mikado" to "Pacific"	.. 4
Lockheed "Lightning" 5
Through the Rockies in a C.P.R. Cab—I, by Edward H. Livesay	.. 6
"Stringbags" the Sailor, by John W. R. Taylor	.. 14

P.R.U.

I—The Development of Air Photography

By C. G. Grey

Founder of "The Aeroplane" 1911, Editor until September, 1939

THE simple letters P.R.U. stand for Photographic Reconnaissance Units. They are units of the R.A.F. mounted in extra special aircraft and equipped with extra special cameras which take photographs of enemy territory from heights, at distances and at speeds which before this war would have been unbelievable—and the figures keep on going up and up.

P.R.U. people are very modest. We hear little or nothing about them in the Air Ministry's official stories, although we see a lot of the pictures which they take of ruined cities and burst dams and so forth. One of the most important jobs of the P.R.U. pilots is to keep out of sight and hearing of the enemy, because they want to get pictures and get home, not to stay and fight. So P.R.U. stands for prudence, but they carry their self-effacement and modesty so far that it might almost stand for prudishness as well.

In fact the P.R.U. are the eyes of the Air Force, and consequently of the Army, and largely of the Navy as well. Before a bomb-raid or an attack on land, or a naval bombardment, over go the P.R.U. and bring back precise pictures of the target. And after it is over, soon after and long after, out they go again to see the results.

And they keep tab on enemy warships as well, as I will show later. They tell the Navy where the enemy's ships are, and they bring back pictures of empty anchorages or docks to show that the enemy fleet has escaped again. But that is another story.

Photography from the air was naturally one of the first developments of flying, just as was bombing. As soon as men

flew, intelligent soldiers began to talk of seeing "behind that hill." And of course photographers thought of recording what was to be seen—I took some quite good photographs from the air of the Army's first aeroplane sheds on Lark Hill, on Salisbury Plain, and of the Navy's first air station at Eastchurch in the Isle of Sheppey, in 1912; and there were lots before that.

The war 1914-18 soon forced forward air photography. One of the people who did most to push it was young Captain Moore-Brabazon, of the Royal Flying Corps, who had been one of our few first-class racing motor-drivers, in about 1907-8, and became No. 1 air pilot in the Aero Club list in 1909. He got a Military Cross for his gallant photographic work during that war. He is now Lieut. Col. the Lord Brabazon of Tara, P.C., M.C., and he is doing great work in planning our Air Transport for after the war, and in criticising our air



Some Camera! An airman of the P.R.U. is here seen toting a Williamson "Eagle" Camera to a "Spitfire."

activities, or inactivities, whenever and wherever they need it.

Between wars air photography went ahead well, chiefly along two lines. The first, and most important was Air Survey. This produced a huge crop of elaborate instruments with which to make proper maps from vertical photographs. The Germans, with their scientific skill and patience, produced an astonishing apparatus, about the size of a motor bus, which when you gave it a vertical or oblique photograph to look at, presented to you at the other end, complete plan and elevations of the object, or a contour map of the country.

I may say that the leader in Air Survey

in this country was my friend Major Hemming, who had specialised in photographic reconnaissance in 1917-18. He, with Mr. Alan Butler, now Chairman of the great de Havilland Aircraft Co. Ltd., who make the "Mosquitoes," built up the Air Survey Co. Ltd., and made maps in all sorts of places in Africa, Asia, and Australia. They tried to induce the High Authorities to let them revise our Ordnance Survey maps, which were half a century old and hopelessly out of date, but apparently nobody other than a party of Royal Engineers with chains and theodolites may touch those sacred objects. Also Major Hemming, just before this war, imported one of those huge German contouring machines, with quaint results which I will tell later.

A secondary activity of air photography between wars was the taking of pictures, from low levels, of private houses and estates, and industrial property, factories, and such-like, and of civic centres, public parks and so on, as souvenirs, or for town-planning, or as guides to builders—their uses seemed endless. There is a funny story hereabouts.

A friend of mine, who specialised on this work, made a habit of flying round and snap-shooting any striking-looking house which he might pass on his way back from his ordered job, if had some films left. He would "pin-point" the house on the map, find out who owned it and send some sample prints to the owner and ask whether he would like to buy some. From this side-line he made quite a nice little addition to his income.

One day he took a fine looking place, which he found belonged to Sir John Reith, then the boss of the B.B.C. and later of Imperial Airways, which was absorbed into British Overseas Airways. He is now Lord Reith. Instead of an order for pictures, the first thing the photographer got was a visit from the police, who wanted to know all about him and what right he had to go photographing gentlemen's property unasked, and so forth and

so on. The police seemed to think that he was part of a new sort of burglary gang, who made a photographic reconnaissance of the premises to be burgled.

I still do not know whether Sir John Reith thought so, or whether sending the police was a deep Scottish joke—as might



The same airman loading the camera into the "Spitfire." These aircraft carry two of these big cameras set at an angle to one another so that they cover a strip of country on each side of their track, and overlap in the middle. Smaller cameras also are carried.

be inventing the name British Overseas Airways Corporation, or the B.O.A., for the boa-constrictor which swallowed Imperial Airways and all our smaller air-lines.

During the last years before this war the R.A.F.'s photographic section was very good. The famous Williamson Mfg. Co. Ltd., whose air cameras had been created and then developed during 1914-18, had gone still further ahead, and we certainly had the best cameras and lenses and films and methods in the world, when war broke out. But the imagination of those in charge had not quite looked far enough ahead to see what particular demands would be made on the photographic squadrons of the R.A.F.

They thought in terms of the last war, of photographing trenches for the benefit of the artillery, or to help in planning infantry attacks—so we had the quaint and slow "Lysander" for Army Co-operation. Or they thought of photographing the enemy's lines of communications or back areas, or supply bases—and for that we had the rather quicker "Blenheims" and "Battles."

They also thought of taking pictures of enemy towns from very high up. But some of our photographic (Continued on page 34)

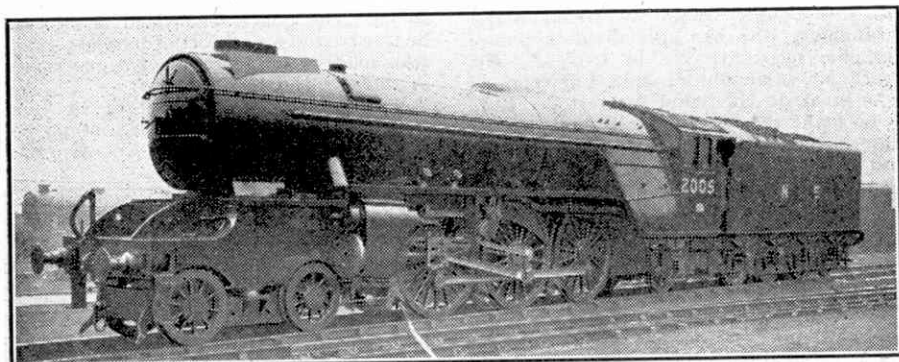

L.N.E.R. No. 2005, formerly of the 2-8-2 wheel arrangement, now reconstructed as a "Pacific." Photograph by courtesy of the L.N.E.R.

From "Mikado" to "Pacific"

An Interesting L.N.E.R. Locomotive Conversion

ARE-BUILDING that has just taken place on the L.N.E.R. foreshadows the disappearance of the only 2-8-2 express passenger locomotives that have appeared in this country. These were six in number, forming the "P2" class. The first two were built in 1934, to the design of Sir Nigel Gresley, and the remainder followed in 1936. The engines were introduced for operation on the difficult route between Edinburgh and Aberdeen, and apparently they have not fulfilled expectations in regular service.

The 2-8-2 wheel type has been known as the "Mikado," a name that is now being replaced in the United States by the name "MacArthur." The range of operation of the L.N.E.R. representatives of this class, working in the Scottish area, will be greatly extended when all of them have been re-built. In their new form they have the 4-6-2 or "Pacific" wheel arrangement and their rigid wheelbase is reduced from 19 ft. 6 in. to 13 ft., a change that will give the engines much more freedom on the curves that abound on the Scottish lines of the L.N.E.R. The first engine to be transformed in this manner is No. 2005, which is doing good work in the Scottish area.

The new bogie, which takes the place of the existing pony truck and leading coupled wheels, is largely of welded construction. It is of the side support pattern taking the weight of the main frame through spherical surfaces on to bronze slippers, and the centre line of the slippers

is in direct line with the main bogie frame. The side control of the bogie is by means of helical springs. The original engine already incorporated a spliced front end portion to the main frame and the renewal of this front end only was necessary. The frame from immediately behind the original leading coupled wheels backward has been retained unaltered.

Although as many as possible of the original parts, including the outside coupling and connecting rods and the outside motion details, have been used again, the conversion has included the substitution of a separate Walschaerts valve gear for operating the valves of the inside cylinder, which in the original engine were operated by a lever from the outside gear. The new inside motion plate which is thus necessary, and which also forms the main front end support for the boiler, is of welded construction, thereby eliminating the need for the provision of any new steel casting frame stays.

The main drive has been divided between the leading and second pair of coupled wheels. The outside cylinders drive on the second pair of coupled wheels and the inside cylinder on the leading pair of coupled wheels. The exhaust passage from the outside cylinders is taken outside the main frames to the inside cylinder casting, making a single blast pipe base in the smoke-box to take a double blast pipe and chimney similar to that fitted to the other 2-8-2 engines in service in Scotland.

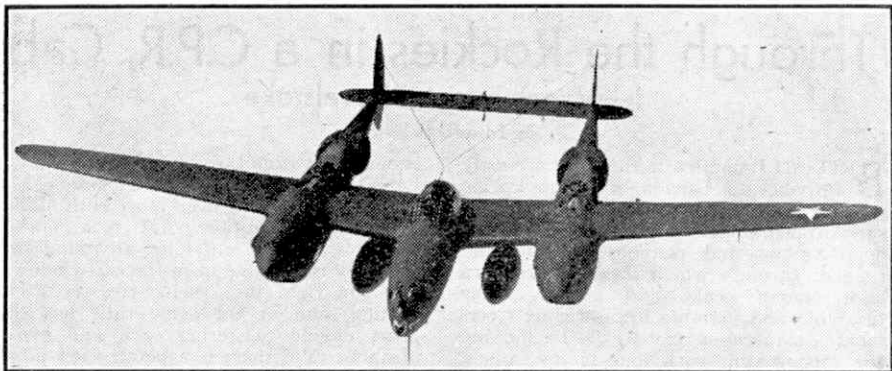

Lockheed P-38 "Lightning" with extra fuel tanks carried under the wings. Photographs by courtesy of the Lockheed Aircraft Corporation, U.S.A.

The Lockheed "Lightning"

HARDLY a day passes without official mention of Lockheed P-38 "Lightnings" in action on one or more of the war fronts. They have been in service with the Royal Air Force since the summer of 1942, and are now being extensively used by the U.S. Army Eighth Air Force in Great Britain. Operating as fighters and fighter-bombers from bases in this country they have carried out very many successful "sweeps" over enemy-occupied countries in Western Europe, and in their latest role of long-range escort fighter they provide protective cover to U.S. heavy bombers making daylight raids on targets far inside France and Germany. "Lightnings" played an important part in the victorious North African campaign, and in air attacks on Sicily and Sardinia, and they are now being used with good effect in the conquest of Italy. On the other side of the world aircraft of this type operating with the U.S. Army Fifth Air Force have repeatedly proved their superiority over Japanese fighters.

The "Lightning" first appeared in public in February, 1939, when it flew across the United States in 7 hrs. 4 min., averaging 400 m.p.h., but it marred this achievement by crashing near its destination.

Modifications made to the design since then have done away with the tail flutter noted in the original machine, and have included the fitting of improved engines and guns of heavier calibre. It is an interesting example of the twin-boom type of all-metal middle wing monoplane, with a wing span of 52 ft. and length of 37 ft. 10 in., and it is only 9 ft. 10½ in. high. In place of the usual long fuselage it has a streamlined nacelle that projects a fair distance in front of the wings and has its rearward end in the wing trailing edge.

The fixed 20 mm. cannon and the four machine guns are grouped in the nose of this nacelle, and farther aft in it is the pilot's cockpit. The machine guns are placed so that their bullets stream straight ahead instead of converging to form a "cone of fire" concentrated at one "ideal" range, as in the case of

most wing-mounted armament. As far as the "tracers" reach, the fire from the "Lightning's" guns is withering, and its deadliness in combat was proved when a flight of these aircraft in the Aleutians shot down five Japanese "Zero" fighters and a 4-engined flying boat during a single dive.

The two 1,150 h.p. "Allison" engines of the "Lightning" give it a top speed of about 360 m.p.h., and the slightly more powerful engines of the same type fitted in the "Lightning" II increase the speed to 380 m.p.h. In both versions the engines are mounted in nacelles that extend backward behind the wing in the form of long tapering booms connected at their stern by the horizontal elevator of the wide tail unit. The vertical fins of this unit are built integral with the booms.

The "Lightning" has a normal range of about 1,000 miles, and the fuel is carried in tanks in the wing centre section. When employed as a bomber escort on long-distance raids it requires more fuel, and this is carried in two detachable tanks clamped, with releasable brackets, under the wings. These tanks increase the range by at least 50 per cent., and after their contents have been used they can be

jettisoned at will by the pilot. Much care was taken to ascertain the most efficient shape of tank, and the Lockheed research engineers tested 31 types of droppable tanks in a wind tunnel before designing the streamlined shape adopted.

The tanks are made in two halves, stamped out in huge hydraulic presses, by sub-con-

tractors who deliver the half-shells to Lockheed Plant No. 4, where the tanks are assembled by scores of men and women working in three 8-hr. shifts. Specially designed welding plant and a conveyor system planned just for this tank assembly job enable the employees to complete a total of 130 tanks per shift. The average output for all three shifts is one tank every 4½ min.

When employed as a fighter-bomber the "Lightning" carries two 500 lb. bombs in place of the detachable extra tanks.

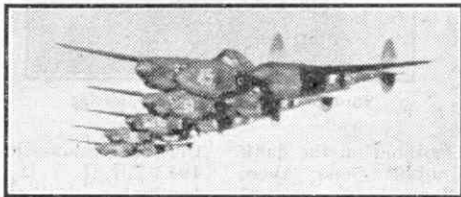

"Lightnings" flying in formation.

Through the Rockies in a C.P.R. Cab

I—Vancouver to Revelstoke

By Edward H. Livesay

BRITISH Columbia is the most westerly Province of Canada, and the Pacific laps its shore. Picture a sea of mountains, snowcapped, mist enshrouded, scarred with deep valleys and canyons, fir-clad and rugged, through which icy torrents born high among peaks and glaciers come tumbling and foaming into swirling rivers making a tortuous way to the Pacific and the setting sun; with four major ranges, the Gold, Cascade, Selkirk and Rockies ribbing the Province from North to South. That is British Columbia.

Through this awe-some wilderness the C.P.R. follows a winding trail from tidewater at Vancouver to "The Great Divide" at Stephen in the heart of the Rockies, 5,337 ft. above sea-level, on the ridge of the Continental roof. Here an eastbound locomotive reaches the summit, with its heaviest work well done; there is nothing more to worry about in comparison right through the 2,000-odd miles to Montreal. Twisting and turning, rising and falling, threading canyons, diving through tunnels, the line picks a determined way through this primal wilderness, here finding a precarious foothold on the flank of a towering mountain mass, there running along a shelf cut in the vertical side of a precipice high above Fraser or Kicking Horse river, boiling along either far below or close alongside. If you revel in magnificent scenery, here you have it; if you are a railway enthusiast, fascinated by great engines tackling steep gradients with heavy loads, you will be more than satisfied with what you will find in B.C.

As seen from the train it is all absorbing

enough, but from the cab of the thundering Leviathan hauling "*The Dominion*" or "*Mountaineer*" it is even more enthralling. From that vantage-point you watch Nature's wonders unfolding all round you in a way impossible from the car-windows; you run right into them; you see them coming, and at the same time feel the great engine mastering each and every obstacle. Yet there is a better view-point still—the cowcatcher! This beats even the cab as a grand-stand seat. Well, we are

going to see these wonders from both positions, so let's "get cracking!"

Space limitations make it impossible to do full justice to the whole 641-mile stretch from Vancouver to Calgary, though it is all spectacular; we shall have to be rather sketchy as far as Revelstoke, where the really big engines come on for the tremendous work through the Selkirks and Rockies. However, we'll join the engine at Vancouver Shed, just to get used to things—to "get our engine legs" as it were. It will be either a "Pacific" of the older 2700 class, with 5 ft. 9 in. drivers, or a modern "Hudson" 4-6-4 of

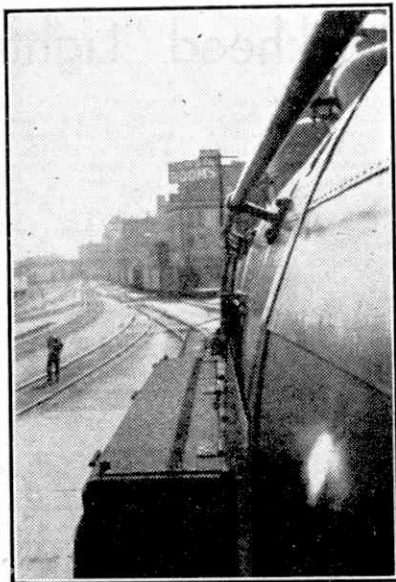

Through the fireman's window, leaving Vancouver.

the 2800 class described in the March 1943 "*M.M.*" If the train is heavy and our luck is in, it will be of the latter type, so let us assume it is No. 2864, which personally I much prefer, as the cab is roomier and more comfortable, and the riding better, thanks to the trailing 4-wheel truck. (Incidentally, did you know there is only one express engine in Britain with four wheels under the cab? No. "10000" L.N.E.R., made up from the "left over" parts of the water-tube boiler

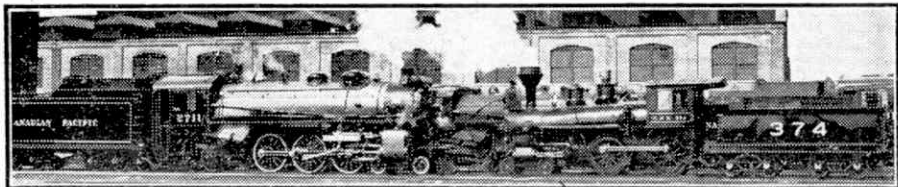

No. 2711, one of the 2700 class "Pacifics," at the locomotive depot. In striking contrast is No. 374, a replica of the first engine to reach Vancouver, in 1885. Photograph by courtesy of C.P.R.

compound "Hush, hush" experiment). Both classes are oil-burners, because oil on the Coast is cheap and forest fires are expensive.

Everything being "all set" for the run, the beautiful chocolate, black and gold engine shoves off for the Depot (station in English) through a mile-long tunnel under the city, backing on to the train, which may weigh anything from 700 to 1,200 tons; the former load is considered light. The Conductor (Guard) hands the "Train Orders" up to the crew, the air-whistle in the cab sounds its "Right away" signal, two blasts, and with cylinder-cocks hissing viciously No. 2864 moves majestically out of the station, 379 gradient-canyon-infested miles to Revelstoke ahead of her. There she will come off to make way for a gigantic 350-ton 2-10-4, but the coaches will go right through to Montreal, a

For some distance after leaving Vancouver most of the scenery is on the left; *your* side. You will be sitting in a comfortable seat behind Fireman Pike, looking across the cab at Engineer Fee. Fee, by the way, handled No. 2850 on the Royal train over this Division; he has recently retired after 45 years with the C.P.R. We are running along the shore of Burrard Inlet, the inner part of Vancouver's fine harbour; across the water are towering mountains, snow-capped in winter, but this is summer, and they are mist-shrouded.

When I am running along this stretch of track, somehow I always think of the "Royal Scot's" visit in 1933, and how, aching with home-sickness, I watched her leave Vancouver in pouring rain on the first lap of her long trip back to England. I never dreamed that a year or so later I should see her in Willesden Shed, and

subsequently spend an evening at Carlisle with Gilbertson, her driver on that memorable N. American tour, in his pretty home, listening to him "fighting the battle o'er again"; nor that next day *he* would be coming to the station to see *me* off on the footplate of "Duchess of Hamilton" hauling the southbound "Coronation Scot." It is the unexpected that often happens!

The level Fraser

river delta ends at Ruby Creek, 81 miles, double track becomes single, and we begin to climb into the first mountain range. It is very pleasant in the clean, comfortable cab, so roomy and dustless, thanks to oil-firing, and the big "Hudson" rides well. Pike attends to most things without leaving his seat, thus being more generally available as additional look-out, and as guide,

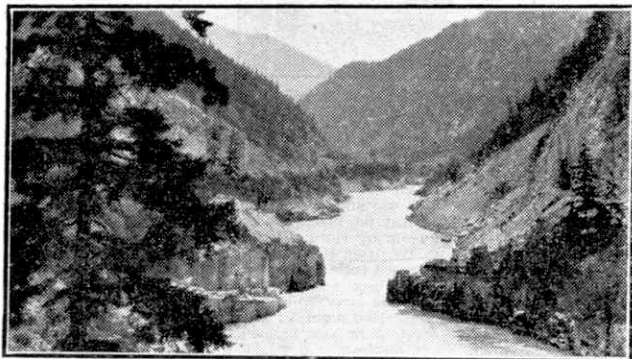

Fraser Canyon: C.P.R. on left, C.N.R. on right.

total distance of 2,882 miles.

The booster gives us a "chuck up" at the start, a boost, in fact, and here may I say that No. 2850, the "Royal" engine, which I rode out of Fort William, as described in the March 1943 "M.M.," *did* have this useful auxiliary on that occasion—I must have been wool-gathering to have forgotten it!

philosopher and friend to me—or you in imagination. Sometimes he feeds sand through an inspection-hole in the fire-door, to be sucked through the tubes, cleaning off the sooty deposit that forms in them. By the way, the L.M.S. "Princess Coronations" have a sand-gun to do this.

The air-whistle sounds at intervals with a message from the Conductor, two blasts for "go" or "stop," three for "stop next station," and so on, the engine whistle repeats it to show it has been understood. Its deep-toned, mellow note gives tongue too 'before' every level-crossing, in two longs, a short and a long. Trackside signals are automatic colour-light, "upper quadrant"—that is, rising to "clear," instead of falling. Readings are always repeated across the cab viva voce: "Clear Board!" when "off"—"Red Board!" when "on."

A peep into the fire-box reveals a swirling mass of dazzling white flame, all from one burner at the back, smoke only showing from the chimney when shutting of the regulator upsets the fuel-air ratio and catches Pike napping, or when otherwise engaged—he is generally on the look-out to forestall this.

We are running through the spectacular Fraser Canyon now, high above the river, looking down into it, or across at the C.N.R. on a similar shelf the other side. The historic Cariboo Trail comes through with us, the first road to reach the Coast, hacked out by the pioneers of a century ago because "there was gold in them thar hills," and the "rush" was on. It finds a foothold where it can, sometimes above us, sometimes below; long stretches were buried under the C.N.R. grade, and a fresh location had to be found. Hell's Gate is passed, where the river boils through a mere 100-foot gap in the rocky ramparts, the white water foaming and tossing, and salmon leaping as they fight their way upstream to the spawning grounds. And so into North Bend, where Fee and Pike hand over to Blakeley and Harkness, at 2.25 p.m., 129 miles in 265 stops—this is not "The Dominion," but "Train No. 2." Average speed 29 m.p.h., not at all bad under the circumstances.

Leaving North Bend we enter the "dry belt," and the soft air and misty cloud-capped mountains give place to yellow-brown soil, sage-brush and stunted tamarack trees. We and the C.N.R. change sides at Lytton—named after Bulwer Lytton, the Victorian novelist, who was Colonial Secretary at the time of the '58 Gold Rush. The Thompson Canyon begins here, wider and less rugged than the Fraser, through sun-baked naked hills. It was delightful, this warm summer day, sitting in a comfortable "stuffed seat," the soft breeze fanning in at the open window off the shining waters of the Thompson river, here placid, and wide as a lake, No. 2864 forged sturdily ahead on the winding shelf, snaking round curves, diving through little tunnels, rumbling over culverts under which white snow-water cascaded down from the mountains, with the train coiling and uncoiling behind like a whip-lash. The exhaust kept up its

harsh continuous snarl, and faintly brown, rocketed straight up into the warm air from the quivering stumpy chimney before curling back high over the cab. Section-gangs (platelayers) were passed, working stripped to the waist, tanned and copper-coloured like Red Indians. They wove to train-crews, who always return the greeting; it is traditional, and rank bad manners not to do so. A rival C.N.R. train winds along its ledge across the river, and a white plume of steam shows above the engine; long after, the wailing note of its whistle comes across the canyon. And so into Kamloops, "The Meeting of the Waters," the N. and S. Thompson rivers, the second Divisional point; time 7.10 p.m., 121 miles from N. Bend in 275 minutes, 26 m.p.h., with over a dozen stops.

The ground-crow services the engine, fitting pneumatic grease-guns to nipples here and there; if No. 2864 were a coal-burner the ash-pan would be raked out. Again the change-of-watch is made, Engineer Dixon and Spenser coming on.

We are out of the Canyon now, and near the western end of Shuswap Lake the shades of night begin to fall, so cab-lamps and headlight are switched on, current for them being generated by a turbine-driven dynamo on top of the fire-box. A single lamp in the cab roof throws shafts of light through a slotted screen on to various gauges, preventing dazzle. A stiff climb from Chase up to Notch Hill, over 500 ft. in 10 miles, does not call for a pilot, our 700-ton load being light. I remember on a previous trip a big 2-10-2 backing on with a tremendous shock, and the engineer remarking dryly: "I guess

he did that so we'd know he'd come!"

It was quite dark by this time, and the headlamp flooded the track with silver just as the lamps of a motor car light up a road, making every projection and wayside object stand out white and ghostlike against ink-black shadow. Mysterious shapes flitted by among trailing wisps of steam, seen but faintly in the train light, and disappeared in the darkness. I sensed rather than saw the mountains that I knew were there outside the narrow field of light, and the lake over which a blanket of mist had crept. Cool, clean night air drifted off the water, bringing a scent of fir and bracken into the cab. We seemed cut off from the world, a little community of our own, rumbling on into measureless black space. But it was warm and cosy in there, dimly lit by the shaded lamp, and this, combined with the long hours of vibration and mountain air, began to have their effect. I found myself nodding, occasionally taking forty winks and waking with a jerk to find my pencil and notebook on the floor, and when finally I fell clean off the seat it was evidently time to quit. So at Scamous I retired to the train, "to get my head down," as they say in the Navy, knowing nothing more until the voice of the Conductor roused me with "Revelstoke—you're stopping off here, aren't you?"

Sleepily collecting my gear, I staggered off to the hotel: time, 12.30 a.m., 129 miles (Cont. on page 34)

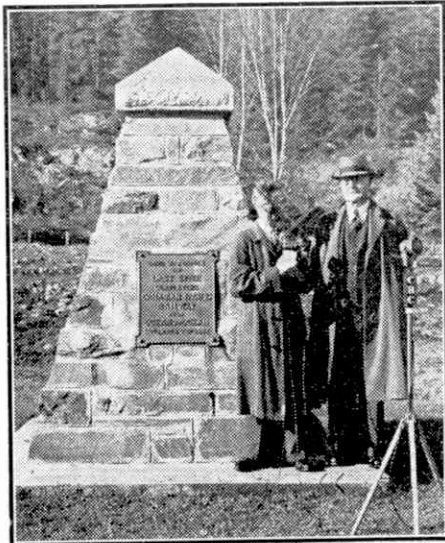

Cairn at Craigellachie where "the last spike" was driven on 7th November, 1885.

Have You Ever Thought About This?

How Do Electric Clocks Keep Time?

WHY are clocks always slow when we want to catch buses or trains? Perhaps it would be truer to say that they are too often blamed by people who miss trains or by office boys and typists who arrive late at work. Clocks do not really deserve to be treated in this manner, and it is fortunate for those who vilify them that they cannot strike back!

All the same, adjusting an old-style clock to keep it exactly right has aroused the worst instincts in many men. The bob on the pendulum has to be raised or lowered by turning a screwed nut, and the adjustment is so fine that the correction is easily overdone and repeated efforts are necessary. Even when everything seems right the wretched clock usually begins to creep ahead or to fall behind, and perhaps it will go completely astray in a day or two, when it thinks it is forgotten. The wireless time signals too, although they help very considerably, may only call attention with maddening frequency to the need for fiddling with a contrary-minded clock. No wonder therefore, that we have welcomed the electric clock, which looks after itself in an almost uncanny way. We just plug it in to the mains supply, provided this is alternating current, and everything is all right—unless of course the current fails!

A Special Motor Does It

Like most apparent miracles the accurate timekeeping of an electric clock has a remarkably simple explanation. The electric motor that drives the works is synchronous. This is a fine high-sounding word with which to impress those who, unlike "M.M." readers, know nothing of electricity, but all it means is "at the same time." It is used to describe the kind of motor fitted in electric clocks because these all run at the same rate, that is they take the same time for a revolution. Their speed depends on the frequency of the electric current, or the rate at which it changes direction, and in most parts of the country this is now standardised at 50 cycles, or 50 times a second. Gearing is used, as in an ordinary clock, to reduce the motor speed to that wanted for the hour and minute hands. A motor of this kind has to be started by giving it a flick,

but special arrangements can be introduced to make an electric clock self-starting.

A Master Control

What all this boils down to is that an electric clock will keep the right time so long as the mains current changes its direction just 50 times a second, no more and no less. If the changes take place more than 50 times in a second the clocks will run too fast: office boys and typists who get up late should pray for fits of laziness that will make the changes less than 50 times in a second, for then the clock too will be a laggard. There is a guardian angel at the power station, however, whose mission is to see that the clocks get current that behaves properly. This is the engineer in charge, who has in front of him a meter that tells him exactly what the frequency is. Nowadays this meter in effect is a very accurate electric clock, which he compares with a standard clock that is guarded and cared for to such an extent that it practically never varies. The two clocks drive indicator hands at a steady rate round the same dial. One hand is red—that is driven by the current; the other, a black one, is controlled by the master clock. As long as the two hands go round together all is well, but if one lags behind the other something has to be done. If the red hand falls behind, the generators are speeded up to make up for lost time; and they are slowed down if it is the black hand that falls behind in this strange race, in which the competitors never get far away from each other and are brought together again by a master hand if they part company.

Hard-worked Slaves

The large electric clocks seen in a huge building or in a great railway station are not driven by synchronous motors but are governed by impulses transmitted to them electrically from a master clock. The clocks so controlled are sometimes called slave clocks. As would be expected, each master has many slaves bound to obedience, each made to show the right time by a tireless series of impulses given to them at half-minute intervals. There is no rest or escape for these slaves.

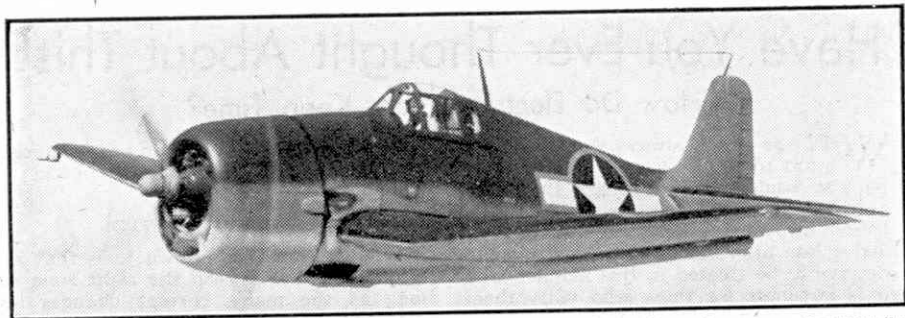

The U.S. Grumman "Hellcat," one of the largest single-engined fighters in service, and now operating with the Fleet Air Arm. Photograph by courtesy of Grumman Aircraft Corporation, U.S.A.

Air News

Grumman "Hellcat" Fighter

The latest U.S. ship-board fighter, the Grumman "Hellcat," is now in service with the Fleet Air Arm. It was first used by the Americans during the carrier raid on Marcus Island on 1st September, 1943, and looks very similar to its forebear, the "Wildcat" ("Martlet"), but has a 2,000 h.p. Pratt and Whitney "Double Wasp" engine which gives it a speed of over 400 m.p.h. Grumman engineers report that compared with the "Wildcat" it has an increased range, greater ammunition capacity, provides better all-round vision, and has a wider undercarriage to facilitate carrier landings in heavy seas; also it has the same excellent manoeuvrability as the earlier machine. The wings fold backward in the British style, and armament includes six .5 in. machine guns in the wings.

The price of £6,000 for the "Hellcat" compares favourably with that of £11,000 for the "Wildcat," and proves that the new machine has been carefully designed for ease of production. J. W. R. TAYLOR.

Another Record Transatlantic Flight

A new record for a non-stop transatlantic flight from Montreal to the West coast of Great Britain was set up on 29th November last year by Capt. Richard Allen, who covered the 3,100 miles in 11 hrs. 35 min. He was flying a Consolidated B 24 "Liberator" on the R.A.F. Transport Command North Atlantic Ferry Service for British Overseas Airways. The aircraft was helped by a tail wind which averaged 45 m.p.h. but no attempt was made to achieve a record crossing, and the machine never exceeded its normal cruising speed. The full weight of machine and cargo was 56,000 lb. Among the cargo was a great deal of Christmas mail for the Canadian Forces in Great Britain and the Mediterranean war zone.

Capt. Allen beat the previous transatlantic record for a flight from Montreal by 21 min. This earlier record was set up in October, 1943, by Capt. M. B. Barclay, who was piloting an Avro "Lancaster" on the Canadian Government Atlantic service operated by Trans-Canada Air Lines.

Within a week of Capt. Allen's notable flight a "Liberator" of R.A.F.

Transport Command took off from Halifax, Nova Scotia, and 13 hrs. 43 min. later landed on an airfield in the London area. This was the first transatlantic flight from Canada direct to the London area. On board the aircraft were Air Marshal L. S. Breadner, the new Air Officer Commanding-in-Chief, Royal Canadian Air Force overseas, and Air Vice-Marshal M. R. Anderson, the new Deputy A.O.C.-in-Chief of that overseas force; and other high officers.

Brazilian Air Line Developments

The Brazilian air transport company formed to replace the banned Syndicate Condor, the German Lufthansa organisation, have taken delivery of four Douglas DC-3 transports sold to them by the U.S. Defence Supplies Corporation. The United States also sent to Brazil 12 technical experts to train Brazilian personnel in the operation and maintenance of U.S. transport aircraft.

Canadian Air Route Survey

Plans for an all-Canadian air route to the Far East are behind surveys now being made from Edmonton down the Mackenzie River, according to the Canadian Minister for Trade and Commerce. He also said recently that preparations for a direct air service between Edmonton and Winnipeg. to be worked by Trans-Canada Air Lines, are to be put in hand.

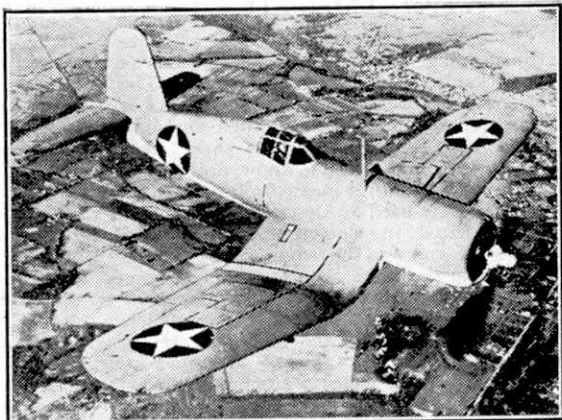

Another U.S. naval fighter, the Vought-Sikorsky "Corsair." It has a top speed of over 400 m.p.h., and is armed with three 0.5 Browning machine guns in each wing.

The Heinkel He 178 Heavy Bomber

The Germans claim that the Heinkel He 178 4-engined bomber had been used recently in raids on this country. The He 178 presumably supersedes the disappointing He 177 that at one time was put forward as being capable of raiding New York from Dakar. The He 177 was intended to have extending wing-tips to reduce wing-loading for take-off, but apparently this device proved too complicated for production, and the new machine is assisted on take-off by a winch. Once in the air rockets are used to increase the speed and enable it to carry out tip-and-run raids in the best German tradition, with a heavier bomb load than that carried by the fighter-bombers that recent heavy losses have forced the Luftwaffe to employ.

With the Heinkel factory at Rostock in its present heavily-damaged condition after R.A.F. raids earlier last year, it is extremely unlikely that the Germans have a very strong force of these aircraft, and well-informed circles put the number at a maximum of 100.

Record Flight by World's Largest Flying Boat

"Mars," the biggest flying boat in the world, and now in use by the U.S. Naval Air Transport Service as a cargo transport, began its duties recently by making a record non-stop flight of 4,375 miles, from Maryland, U.S.A., over the Atlantic to Natal, in Brazil, with 13,000 lb. of Christmas mail for the armed Forces overseas. The round trip to Natal and

the Heinkel He 178 used recently in raids

U.S. Aircraft Modifications

Many modifications are being made to aircraft in service with the U.S. Army Air Forces, to meet the

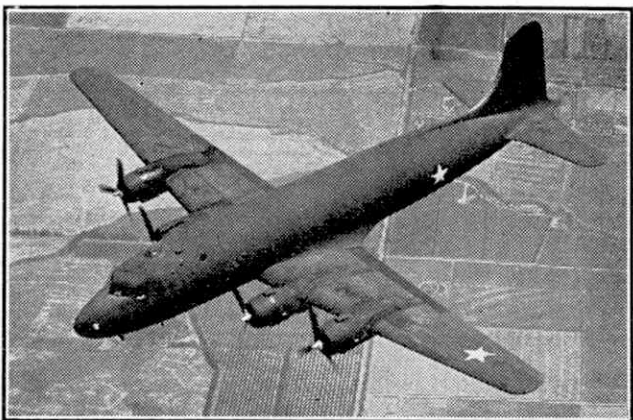

A fine photograph of a Douglas C-54 "Skymaster" transport. Originally designed as a commercial air liner, it has been modified to U.S. Army requirements, and is now in service as a troop and cargo transport.

J. W. R. TAYLOR.

ever-changing requirements of modern air warfare. Recent modifications announced include the fitting of 75 mm. guns to North American "Mitchell" bombers in the "Pacific" for attacks on enemy shipping and armour; planes so modified would prove a valuable asset to the Allied Air Forces as a tank-buster when the invasion of the Continent begins. The gun, which fires a 12 lb. shell, is loaded by the navigator and fired by the pilot.

Some "Mitchells" and Douglas "Havocs" have been modified to include an armament of four cannon mounted in the nose for bomber escort and "intruder" operations. Other "Mitchells" incorporate three large cameras in bulges in the nose, for photographic reconnaissance.

Douglas "Bolo" ("Digby") bombers, which have been used for training purposes in Canada, are now seeing action in the Pacific with modified nose and tail for anti-submarine work.

J. W. R. TAYLOR.

When a "Fortress" bomber of the U.S. Army Eighth Air Force crashed on the village of Deenethorpe, Northants, on 5th December last year, it was stated to be

carrying a bomb load of 6,000 lbs. This is the first intimation of the weight of bombs carried by these machines on operational sorties, and is considerably better than unofficial reports would imply. Most of the bomb load is carried in the fuselage and the remainder in racks under the wings.

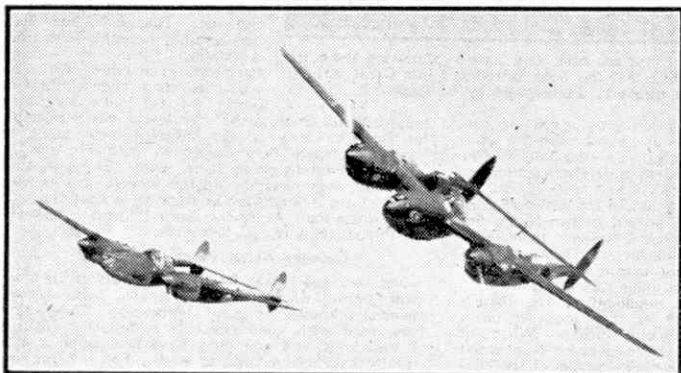

This flying view of Lockheed P-38 "Lightnings" shows well the wide tail unit and the dihedral of the wings. (See special article on page 5). Photograph by courtesy of the Lockheed Aircraft Corporation, U.S.A.

back took eight days, and the 8,972 miles were flown in 55 hrs. 31 min. flying time, an average of 161 m.p.h.

This giant flying boat has a wing span of 200 ft., and is 170 ft. long and 35 ft. high. It was built by the Glenn L. Martin Company, of Baltimore.

Our Wonderful World

Open-Cast Coal Mining

Great interest has been aroused in recent months by the unusual form of coal mining that has been introduced in this country. It is not always necessary to sink deep shafts and drive galleries far underground to win coal; in many places there is coal of good quality near the surface, and all that is necessary to get at it is to dig off the earth, or "overburden" above it to lay it bare. For this work efficient digging machinery is required, and our illustration shows a scene at an open-cast mine, as workings of this kind are called, in which giant mechanical shovels are digging out coal that has been brought to light by the removal of the overburden.

Although new to this country, open-cast mining has been carried on in the United States and in Germany for a considerable time. As long ago as

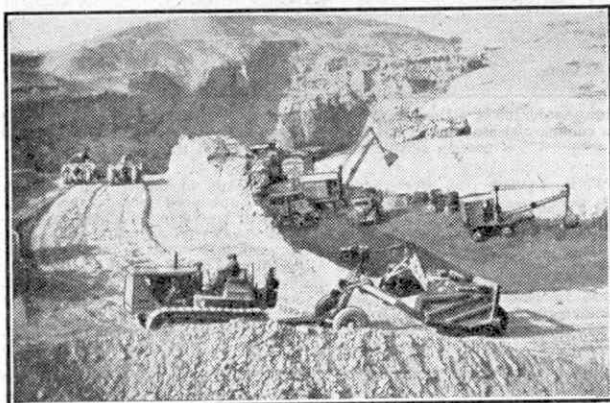

Excavators digging out coal that has been laid bare by removing the earth covering it, a form of mining that has been introduced into Great Britain as a wartime measure. Photograph by C. Tingle.

December, 1930, a description was given in the "M.M." of a giant electrical shovel used for this purpose in the United States. So enormous is the machine that the bucket, a comparatively insignificant item, was large enough to hold 16 tons or so of coal, an amount that in these days would be thought sufficient to provide for the needs of several British homes for an entire year! In fact a small saloon car made a comfortable load for the bucket, which was swung round on the end of its long arm at about 20 m.p.h. when it was being used to gouge out the coal.

Although the machines employed in the British open-cast mine illustrated on this page are on a smaller scale, they are equally efficient. When all the coal has been removed the overburden is returned and levelled by means of carryall scrapers of the kind that have several times been described and illustrated in the "M.M."

Figs and No Figs

Although such things as figs are scarce to-day there is no harm in thinking about them and in anticipating the pleasure of again eating them in unlimited quantities if we wish. A prospect such as this made the mouths of Americans water years ago when the bright idea was entertained of growing figs in California, where the climate is warm and in other respects suitable for them. Fig tree cuttings from

Smyrna, in Asia Minor, were taken over in large numbers and distributed among Californian fruit growers, who had no difficulty in getting them to take root and to grow into fine trees. There was only one drawback—they produced no figs.

When it was realised that something was wrong an expert was sent over to Smyrna in order to find why the trees produced figs there, but not in California. The result of his visit was very surprising, for he discovered that a tiny fly forced its way into the flowers of the fig tree, only to realise apparently that they were of no use to it, and to emerge again as soon as possible. The short stay was sufficient to pollinate the flower, however, and to cause the fig to develop. This strange insect came from wild fig trees growing in the neighbourhood. They themselves yielded no figs, but without them the fig harvest was impossible, for the pollinating insect can only live on the wild trees.

This of course solved the Californian growers' problem. Wild fig trees were grown in California and when they were ready colonies of the insect were rushed over at high speed from the nearest point of North Africa to the New World. Speed was necessary, for the insect passed through its entire useful life course in a fortnight. The plan was successful and the Americans got their figs.

Saving the Orange Groves

There are many wonderful insect stories connected with the Californian fruit industry. One of these concerns the orange groves of that State, which at one time were threatened with destruction by a small scale insect that infested the trees and caused them to wither and die. The scale had been accidentally brought over from Australia, where it seemed harmless. Detective work by scientists soon showed that a pretty red and black Australian

ladybird that lived on the scale insect was responsible for this. Colonies of the ladybird were taken to California, where they descended with glee on the hoard of food awaiting them, with the result that the trees were cleared and the orange groves were saved. Care is necessary in such cases that the cure is not worse than the disease, but no ill results followed the introduction of the ladybirds.

Growing Better Plants from Seed

Not long ago it was found that plants of all kinds grow better when they are treated with certain chemicals known as plant hormones. These have been used with good effect in stimulating cuttings to take root, and now they have been applied with equally beneficial results to seeds. For this purpose the hormones are incorporated in a powder that is dusted over the seeds, either dry or wet, before they are sown.

Rough seeds are dusted dry, and smooth ones are treated wet to encourage the powder to stick to them, and in both cases the seeds germinate quickly and easily, and yield better plants, with stronger roots, than similar seeds untreated with hormones. An interesting discovery is that plants grow best of all when the seed from which they grow is dusted and the hormones are also included in the fertiliser supplied to them.

Sea and Shipping Notes

New Motor Life-boat for Wales

A new life-boat has been built for Pwllheli, Caernarvonshire. She is of the powerful Watson cabin type, 46 ft. long, and fitted with two 40 h.p. Diesel engines that give her a speed of 8½ knots. She can travel 233 miles at full speed without refuelling. Each engine is water-tight and could continue running even if the engine-room were flooded. The boat is lighted with electricity, and has an electric search-light, a line-throwing gun, an oil-spray and a radio telephone.

The new boat is the 29th life-boat to be given to the Institution by Manchester and Salford, and is named "Manchester and Salford XXIX."

Gallant Rescues at Sea

The R.N.L.I. has awarded its silver medal to Coxswain John Matthews, of its life-boat at Moelfre, Anglesey, for his courage and skill in rescuing four airmen. It has also awarded bronze medals to Richard M. Evans, the second coxswain, and Robert Williams, the motor mechanic. Coxswain Matthews already holds the Institution's silver and bronze medals.

The night was very dark, with rain, and the wind was blowing very hard. The airmen in their dinghy had been carried close to the rocks, where fierce seas were breaking. The coxswain could see nothing, but calling on his crew to "hold on to yourselves in case she strikes," he boldly steered for where, somewhere among the rocks, he supposed the dinghy to be. That the life-boat found it without striking the rocks herself was a miracle. One of the airmen had been washed out of the dinghy, but Second-coxswain Evans, the strong man of the crew, lifted him straight out of the water, a great feat of strength.

Bronze medals have been awarded to Mr. James O. Moore, the motor mechanic of the Barrow life-boat, and his son, Mr. Frank Moore, the assistant mechanic, for putting out in a punt, in a gale and pitch darkness, and at great risk to their own lives, to rescue two men from a fishing vessel that was driving ashore and was sunk immediately after the rescue. There was no time to launch the life-boat.

The "Lafayette" Afloat

The former French liner "Lafayette," originally known as the "Normandie," has at last been refloated. It will be remembered that the vessel caught fire almost two years ago while berthed in New York harbour, and later sank and capsized owing to the weight of the water that was poured into her.

The task of salvage has been a particularly difficult one, for the ship lay on her side and 10,000 cu. yds. of mud had entered her hull. The mud had to be removed by blowing it out with compressed air, and

water was admitted in its place so that there should be no sudden uncontrolled change in position. All openings in the hull were made good, and the decks were made watertight to points above the surface of the water and strengthened where necessary, a large force of divers being engaged in these difficult tasks. Pumping operations then began with the purpose of righting the vessel and bringing her to the surface. Altogether 93 pumps were used, and pumping from the various watertight compartments within the hull was carefully controlled so that the vessel slowly and steadily turned over from her position on the mud bottom, and finally came upright and afloat. She broke away from the mud easily, and without

any sudden movement that might have been disastrous, air and water jets being used to prevent any suction effects. The total quantity of water pumped out was 100,000 tons.

Fast Standard Cargo Vessel Design

An interesting feature of wartime shipbuilding in Great Britain is the production of a standard cargo vessel of about 10,000 tons gross with a speed of 15 knots. Some of these ships are being fitted with geared turbines, and others with Diesel engines. They have a single screw and their cruiser sterns give them an attractive general appearance.

There is limited accommodation for passengers in 12 single state rooms, which can be adapted to accommodate two passengers if necessary. Excellent accommodation is provided for officers, and quarters for the

crew are in accordance with modern improved standards. The equipment for handling cargo is elaborate, including four derrick-post masts, and loads up to 80 tons can be dealt with at the main mast. Electric power is used in auxiliary machinery. The upper deck has been made capable of supporting heavy loads without special reinforcement, so that deck cargoes can be carried when necessary.

High Level Docks

When ships are being fitted out much of the material required often has to be lifted through considerable heights by means of cranes. In order to avoid as much of this as possible high level outfitting docks have been introduced in shipbuilding yards in the United States. The new docks have their floors about 30 ft. above water, so that the vertical lift to the deck of the ship being fitted out is reduced to about 10 ft. Inclined roadways allow motor lorries to reach the dock floor easily from ground level. Besides saving power the new docks show economy in time, for tools, stores and other material kept on them are at deck level and workmen do not have to climb up and down between ship and yard so much.

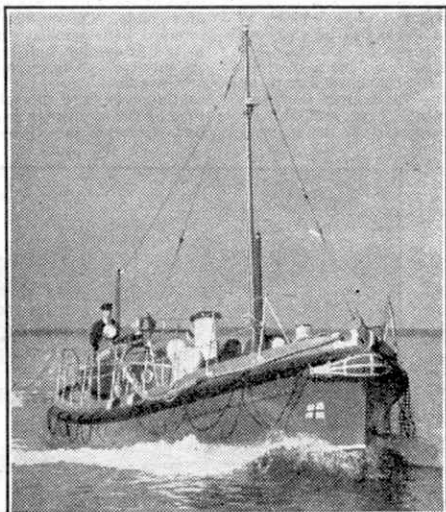

"Manchester and Salford XXIX," a new life-boat stationed at Pwllheli. Photograph by courtesy of the Royal National Life-boat Institution.

"Stringbags" the Sailor

By John W. R. Taylor

VERY few aeroplanes have been subjected to as much unjust criticism as has the Fairey "Swordfish" during the last four years, and yet few aeroplanes could have discharged the varied and exacting duties assigned to this type with such success.

The "Swordfish" was designed in 1935 when the world had just become conscious of the menace of the new Luftwaffe. The latter was equipped with the finest machines in the world, designed for war when the other powers were thinking of peace, thus it had a great technical advantage where warplanes were concerned. The British Air Ministry, fortunately aware of the danger of letting Germany gain supremacy in the air, immediately issued specifications for new types of aeroplanes, and displayed more interest in some of the excellent types developed as "private venture" aircraft by various firms.

The aircraft industry rose nobly to the task given to it, but many of the aircraft developed had to be put into production hurriedly to counter the ever-growing threat. The aeroplanes were undoubtedly good, but they did not incorporate all the features that their designers would have liked to give them. So it was with the "Swordfish." The need for a new torpedo-reconnaissance aeroplane for the Fleet Air Arm was very urgent and no time could be spared to consider the finer points of design. Thus an aeroplane was produced that needed no new methods of construction to hamper production, and yet would perform all the tasks that might be assigned to it.

It was not a handsome aeroplane. It appeared to be held together by a vast number of struts and bracing wires, and soon earned the nickname "Stringbags" from its Fleet Air Arm pilots, who, nevertheless, grew very fond of their new mount in spite of its primitive appearance and slow speed. As will be seen later, its lack of speed more than once proved an asset to the "Swordfish."

It was a three-seat biplane, the pilot occupying the front seat, with the navigator in the middle cockpit and the gunner behind him. The last was provided with a Lewis gun on a ring-mounting and the pilot had a fixed forward-firing Vickers gun. It was capable of carrying a standard 18 in. torpedo or 1,500 lb. of bombs, and was powered by the 775 h.p. Bristol "Pegasus" III engine.

Several squadrons of "Swordfish" were on active service when the war started, both at sea on our aircraft carriers, including the new "Ark Royal," and as shore-based torpedo-planes to protect our coast-wise shipping.

Since then more exploits of gallantry and self-sacrifice have been performed in "Swordfish" than in any other type, and it has earned a great reputation for sturdy construction, ability to take punishment, and reliability, in spite of overloading to an extent that its designers could not have foreseen and which would probably have been considered impossible by them.

As an example of dogged perseverance on the part of the crews, and reliability of equipment, there is probably nothing in the history of flying to compare with the mine-laying operations carried out by F.A.A.

"Swordfish" in the difficult days after the evacuation from Dunkirk. Desperate measures had to be taken to destroy as much German shipping as possible and try to keep the remainder in port. "Swordfish" were the only type available, so, with a very large additional fuel tank occupying the navigator's position and bulging over the top of the cockpit, and with a massive parachute mine slung under the fuselage, the "Swordfish" time and time again plodded at a cumbersome crawl to the Baltic Sea, delivered the mines, and flew the long course back to base with hardly one messer fuel left, and not far from the lairs of the "Messerschmitts" that could have made piecemeal of the almost helpless "Stringbags" in a matter of seconds. This story of unsurpassed heroism has received little publicity but its value is well known to the Admiralty, and the results of the mine-laying are only too well-known to the German High Command.

"Swordfish" from the "Ark Royal" were in action continuously until the "Ark" was "sunk" for the last time by the enemy. In September, 1939, they attacked and damaged the U-Boat that torpedoed the S.S.



The first Fairey "Swordfish" T.S.R. biplane.

"Fanad Head." While participating in the hunt for the "Graf Spee" in the South Atlantic, "Swordfish" sighted the German steamer "Uhenfels," and their signals led to the capture by the Royal Navy of this valuable prize with its £250,000 cargo. During the Norwegian campaign they bombed the Germans day after day against incredible odds.

In July, 1940, the "Ark's" "Stringbags" were called on to perform their most distasteful duty. Attempts to persuade the commander of the French Fleet at Oran to carry on the fight in spite of his Government's collapse had failed, and in order to prevent the Germans from capturing and making use of these mighty vessels there was no alternative but to destroy them. Accordingly Force "H" of the Mediterranean Fleet bombarded the French ships while "Swordfish" laid mines in the harbour. A battleship, the "Bretagne" and two destroyers were soon sunk and the battleship "Dunkerque" beached; the battleship "Strasbourg" made good her escape in the darkness but not before "Swordfish" had secured one torpedo hit on her. The next day "Swordfish" finished off the "Dunkerque," one wave alone scoring four torpedo hits on her.

Actions followed thick and fast for the "Ark's" "Swordfish"; participation in the disappointing De Gaulle expedition to Dakar on 23rd September

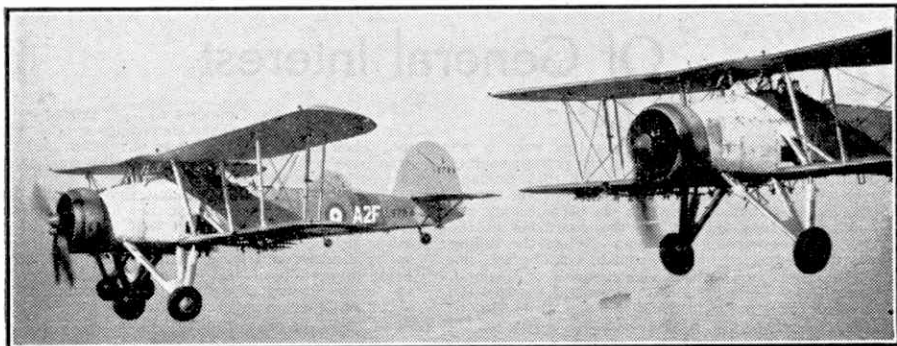

A flight of "Swordfish" circling over the "Ark Royal." Photographs on this page by C. R. Peckham.

1940, bombing raids on Sardinia and Italy, and a torpedo hit on one of Italy's finest battleships, the "Vittorio Veneto" on 27th November.

When the German battleship "Bismarck" ventured out into the North Atlantic in company with the cruiser "Prince Eugen" the "Ark Royal" was again well to the fore. Having sunk H.M.S. "Hood" with a lucky shell in the magazine, the "Bismarck" set off at full speed for home, and it was found necessary to slow her up if the British capital ships were to catch her and avenge the "Hood." Once more the "Ark's" "Stringbags" came to the rescue. A striking Force led by Lieut.-Comm. E. Esmonde scored a hit on the enemy ship that reduced her speed. Later other "Swordfish" helped to shadow the German warship, and two waves of 15 "Swordfish" set out to bomb the enemy. The first wave achieved no success, but the second battled through driving rain and low cloud, with ice forming on their wings, to score another hit that slowed down the "Bismarck" sufficiently to enable the British battleships to establish contact and finish the job. Much of the credit for this success must go to the "Stringbags" which triumphed over seemingly impossible flying conditions to "find, fix and strike" in the teeth of heavy fire. One "Swordfish" came back with 175 holes in her wings and her crew wounded; a number did not come back at all, but Germany's proudest warship had made her first and last sortie.

On 11th November, 1940, the "Stringbags" achieved its greatest success against a powerful fleet in its

own harbour. Two squadrons from the new aircraft carrier "Illustrious" carried out a devastating attack on the Italian fleet in Taranto Harbour. The results were incredible—eleven torpedoes crippled half the Italian Fleet. Two battleships of the "Cavour" and "Duilio" class were badly damaged and beached, and one "Littorio" class battleship damaged for the loss of two "Swordfish."

On 12th February, 1942, the German battle cruisers "Scharnhorst" and "Gneisenau" left their base in France where they had lain since their short but successful sortie into the Atlantic to prey on our merchant shipping. Both ships were required urgently by the German Admiralty for further raids and had gone to Brest for re-fit. Constant bombing by the R.A.F. had prevented this, and the German Admiral finally decided to make a dash for the North German ports where the work could be carried out more easily.

The day chosen for the battle cruisers, escorted by minesweepers, destroyers, flak-ships and aircraft, to slip through the Channel, was foggy, and they were well on their way before being spotted by a reconnaissance aircraft. From that moment every available aircraft of the R.A.F. and F.A.A. was directed against the array of ships, but the heavy bombers were prevented by low cloud from dropping their armour-piercing bombs from a high level and these simply bounced off the warships' armour-plating. Once again desperate measures were needed, and once again "Swordfish" were the aircraft chosen. The only other torpedo aircraft available—"Beauforts"—were too fast to drop between the cruisers and their destroyer screen low enough to launch their torpedoes; a slow, steady aeroplane was needed.

The crews were volunteers, and when Lieut.-Comm. E. Esmonde led the formation of six "Swordfish" in to the attack he knew well that his little force could not escape being blasted to pieces by the massed guns of the German ships. But he also knew, how much depended on the success of his mission, how many sailors' lives would be saved; how many snips would escape destruction, and consequently how many Britishers might be saved the horrors of starvation. Straight into the muzzles of the guns he led his sections; large naval guns, anti-aircraft guns, pom-poms, and even machine-guns, shattered machine after machine out of the sky, but still the remainder flew on. It was not possible to zig-zag to avoid the fire or the torpedoes could not have been launched. The pilots had to maintain a straight, steady course at a fixed height.

Not one "Swordfish" flew out of that hail of death, and it is not even known if they secured any hits on the battle-cruisers, the only indication of their probable accuracy of aim being the fact that the German ships have not yet been out to raid. (Continued on page 14)

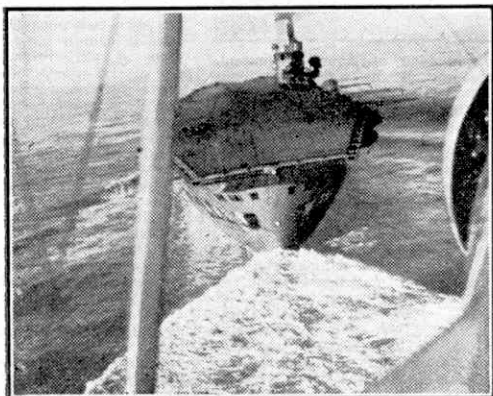

Coming in to land on the "Ark Royal."

Of General Interest

Fire Over England

The photograph reproduced on this page is an interesting reminder of what, until the present conflict must have been the strangest night that England ever had. It was a night of fires, lit however not by enemies, like those with which we became only too familiar in 1940-41, but by the guardians of the land to give warning of danger. When the sailing was daily expected of the Spanish Armada, the aim of which was the invasion and conquest of England, great chains of beacons were organised so that the news of its approach could be signalled without delay. The beacons were placed on towers or hill tops, from which they could be seen for miles, and our illustration shows a typical bearer of the fiery messengers that carried the news of the Armada's approach from Devon to London, and on to the north, leaping from hill to hill and ranging over the entire land until, in Lord Macaulay's words in the well-known poem, "The red glare on Skiddaw roused the burghers of Carlisle."

Prehistoric Fish Brought Up in Trawl

A fish of a kind that flourished 100 million years ago or more, and was thought to have been extinct for 50 million years at least, has been brought up out of the sea off the coast of South Africa in a trawl. At first nobody believed the report, but to the general astonishment it has proved to be true. Here then is a fish that has no business to exist at all, and certainly became a back number millions of years ago, but of which a few specimens obviously lurk, presumably in deep waters.

The name given to this relic of the past is the coelacanth. It is about 5 ft. long and is covered with brilliant blue scales. The specimen brought up in the trawl was almost identical in every respect with coelacanths whose fossilised remains have been dug out of rocks in the Bavarian Alps that were laid down some 250 million years ago, so the fish has made no progress in the long interval and indeed appears to have been a sort of dead-end in evolution. Somehow it has discovered a safe corner in which it could continue its existence.

Fish with Armour

This fish is not the only one that was known as a fossil for many years before it was discovered to survive on Earth. Two of these freaks were found in Australian rivers. They belong to the tribe of fish in armour, for their bodies are covered with thick heavy plates, like those of many others that

are known from fossil remains to have existed on the Earth in bygone ages. They are strange in other ways too. Their fins resemble the legs of reptiles, and they even have good lungs to make it possible for them to live on land as well as in water.

The depths of the sea have never really been explored, and it is certain that they have many other surprises in store for us. All that we know of the fish in them has been learned from specimens brought up by dredges, and these can represent only a very small proportion of the life of the depths. What we know already is sufficiently surprising. Many weird and hideous creatures have been brought up, some of them with brilliant searchlights to light

their way, others glowing with phosphorescent light, and still others with rows of illuminated circles in various colours along their sides that must make them look like liners lit up at night. Lights appear to be necessary to many of these fish, which live in the dark depths of the sea, but there are many that are blind and find their way about by means of sensitive feelers. Many of those carrying lights are able to switch these off or on as they please, using them freely when chasing their prey, and extinguishing them, to vanish in the darkness, when they in turn are threatened.

An Angler of the Deep Seas

To our eyes most of these fish are ugly and fearsome, and huge mouths filled with needle-pointed teeth are common among them. One of them indeed, the sabre-toothed tiger fish, has such enormous teeth that it cannot close its jaws at all. Probably the most fantastic of all these fish, however, is the deep sea fisherman, black in colour and with an enormous head,

which actually carries a rod and line equipped with hooks and bait. The rod sprouts from the top of the upper jaw and has at its end a long filament carrying three horny hooks. As it swims slowly through the water the line is dangled before it and the hooks are lit up brilliantly to attract the fisherman's victims.

A well-known angler fish that lives on Atlantic shores, dangles in front of its jaw a bait carried on a small line growing from its nose. Small fish, crabs or lobsters that are sufficiently curious to touch the bait are instantly seized by the angler, whose jaws then snap involuntarily. This fish even catches wild ducks when fish are scarce, but it is a mere novice in comparison with the triple-hooked deep-sea fisherman, and even the wily catfish, which lies in the mud at the bottom with only its feelers waving in the clear water, to be mistaken by other fish for worms, is not so skilful an angler.



An ancient fire beacon high up above Richmond, Yorkshire. This was one of the warning beacons lighted when the Spanish Armada threatened the country. Photograph by J. D. Robinson.

BOOKS TO READ

*Here we review books of interest and of use to readers of the "M.M." With the exception of those issued by the Scientific and Children's Book Clubs, which are available only to members, and certain others that will be indicated, we can supply copies to readers.
Order from Book Dept., Meccano Limited, Binns Road, Liverpool 13, adding 6d. for postage.*

"AIRCRAFT OF THE FIGHTING POWERS" Vol. IV

Edited by D. A. RUSSELL, M.I.Mech.E.

(The Harborough Publishing Co. Ltd. £1/1/-)

The publication of each new edition of this excellent annual book is eagerly awaited by enthusiastic aircraft model-builders who wish to make scale models of current types of Allied and enemy military aircraft. The book is planned also to appeal to others who are keen on aircraft. Each annual volume deals with machines in service in a particular year, and this new edition covers Service aircraft operating in 1943. It is compiled on the same lines as the previous issues, is printed on good paper and in easily-readable type, and contains 140 splendid half-tone photographs and 1/72 three-view scale drawings of 77 Allied and enemy aircraft. Many of the types dealt with are included for the first time, and the remainder are revisions showing important modifications made to the machines concerned. In each case the specification is supplemented by details of all known performance figures, interesting notes on the history and development of the machine and, in some instances, brief details of its outstanding achievements in the war.

A feature of military aviation last year was the intensive development of gliders and glider training, and illustrations and data concerning the Airspeed "Horsa" heavy transport glider are included in the section of the book dealing with British military aircraft. Among the "front line" aircraft in this part of the book the Hawker "Typhoon" fighter will be a great attraction to model-builders. Several less-known types of aircraft engaged on unspectacular but important duties are included, such as the Taylorcraft "Auster" and Wicko "Warferry" communications machines.

Just over half of the book is devoted to American military aircraft, mostly training types of which three are gliders. Heavier stuff included ranges from the outstanding Lockheed P-38 "Lightning" and North American "Mustang" fighters to the big 4-engined Lockheed "Constellation" transport, capable of carrying about 60 troops and their equipment, to the slightly smaller 4-engined Consolidated "Liberator," which is giving such fine service with R.A.F. Coastal and Transport Commands.

There is one example of current Russian military aircraft. This is the Lagg-3 fighter and fighter-bomber, which has been taking very heavy toll of the enemy on the Eastern Front.

On the enemy side, Japan is represented by a solitary type, the Mitsubishi OB-01 twin-engined bomber, and the 10 German types dealt with range from the well-known Messerschmitt Me 109G and Me 210A-1 to the big Junkers Ju 90S, the latest development of the military version of the pre-war Junkers Ju 90 transport. The uncouth Gotha 242 glider also is included. There is also a valuable summary of the varied international markings used on the military aircraft of the countries mentioned and in the case of Great Britain, the United States, and Germany some useful notes on the regulation colour schemes applied to the various classes of machines.

The book is published by The Harborough Publishing Co. Ltd., Allen House, Newark Street, Leicester, price 22/- post free.

"WHEN THE WORLD WAS YOUNG"

By M. M. MORREL (Harrap. 8/6 net)

Here is a fascinating book on the world, not as it is to-day but as it was, showing how it and life on it have fared through past ages. There is nothing more attractive than the story of the Earth and the growth on it of life in countless strange forms, ending in the triumph of man, its present ruler, and the author has told this wonderful story in a delightful manner that will awaken enthusiasm among her readers.

We begin with the birth of the Earth, the coming of rain and the formation of the seas, in which the first known forms of animal life appeared. Then we trace the slow evolution of the strange creatures of all kinds that have in various ages multiplied upon the Earth. All of us know something about the great reptiles of the dinosaur age, and here we have vivid accounts of all the more important or exciting of these, with stories too of fishes and the shelled and other creatures that came before them.

In these stories we learn something of the Earth itself at various times, with its climate and its plant growth, and finally we come to the development of the mammals, which now pre-

dominate. It is fascinating to read of the first horses, the earliest elephants, primitive birds and other pre-historic creatures, and it is even more exciting to trace the history as far as we know it of Man himself, whether we have learned it from the fossilised bones of the earliest human beings, from their tools dug out of the earth, from their drawings and paintings hidden in the darkest recesses of caves, or from the rubbish they carelessly thrust aside to be patiently dug over and examined in recent years. All these and many other periods in the Earth's history are admirably dealt with, making up a clear account of the most remarkable story in the world.

The book is vividly illustrated with 52 excellent maps and drawings.

"THE RAILWAY HANDBOOK 1943-44"

(Railway Publishing Co. 4/- net)

The 1943-44 edition of this valuable reference book is a mine of information on almost every phase of railway work. It has been revised and brought up to date, and new sections dealing with railways and the war, "Express" traffic in North America and the Railway Companies' Association have been introduced.

The handbook deals chiefly with the railways of Great Britain and Ireland, but gives interesting glimpses of overseas railways in certain sections, notably the one on electrification. Enthusiasts will find in it accounts of train speeds and records, longest tunnels, highest railways, notable accidents, outstanding events in railway history and so on, in addition to a wealth of information on locomotives, rolling stock, permanent way, signalling and railway statistics. Every one of the 120 pages in the book in fact is closely packed with information of some kind, and there is an excellent index.

The book is produced by the Railway Publishing Company Limited, 33, Tothill Street, Westminster, London S.1, from whom it can be obtained direct, postage 3d. extra.

Owing to wartime difficulties, it is impossible to guarantee prompt delivery of books ordered as described at the head of this page, but every effort will be made to ensure speedy despatch.

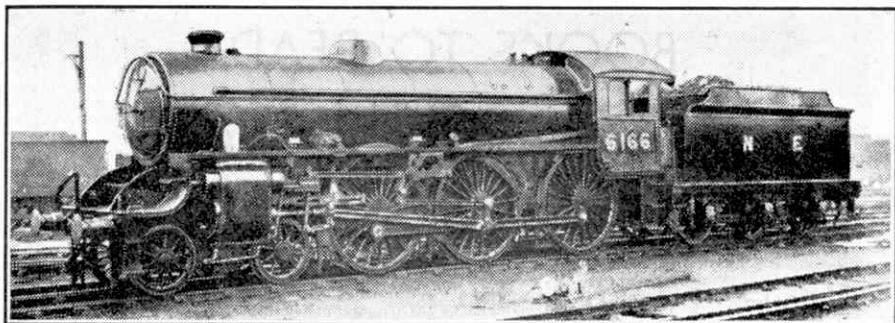

L.N.E.R. No. 6166 Class "B3" locomotive, as now rebuilt with two 20 in. by 26 in. cylinders and a Class "B1" type of boiler. Photograph by courtesy of the L.N.E.R.

Railway News

Another L.N.E.R. Locomotive Conversion

One of the six 4-6-0 class "B3" locomotives of the L.N.E.R. originally built by the former Great Central Railway during 1917-1920 with four cylinders and piston valves actuated by Stephenson link motion, recently fractured its cylinders. The opportunity was therefore taken to rebuild the engine with two cylinders exactly similar to those used on the class "B1" mixed traffic 4-6-0 locomotives and with the "B1" type of boiler, thereby eliminating cylinders and boiler of non-standard design.

The engine thus converted is No. 6166, originally named "*Earl Haig*." Along with No. 6168 "*Lord Stuart of Wortley*" of the same class, she was fitted with Caprotti valve gear in 1929 and re-classified "B3/2."

Before rebuilding No. 6166 had a boiler of length 17 ft. 3 in. and boiler pressure of 180 lb. per sq. in. Now these dimensions are 15 ft. 11½ in. and 225 lb. per sq. in. respectively. The original cylinders were of 16 in. diameter and 26 in. stroke; the new cylinders are of 20 in. diameter and 26 in. stroke, and the tractive effort is now 24,555 lb.

L.N.E.R. Locomotive Notes

New "V2" mixed traffic engines with 6 ft. 2 in. driving wheels of the latest series are out up to No. 3689. Nos. 3686/7 stationed at York have been seen a great deal on heavy East Coast expresses working through between Newcastle and Grantham. British "Austerity" 2-8-0 W.D. engines have appeared on the Great Eastern section, where the American similar type is also numerous. One of the latter, No. 2033, worked a special train over the Cambridge route to King's Cross, G.N. section, where it was the first U.S. 2-8-0 engine to appear.

The locomotive stock for operating the outer suburban passenger services from Marylebone over the joint lines to High Wycombe, Aylesbury, etc. has been augmented lately by two of the 4-6-2Ts built by the L.N.E.R. in 1925 for semi-main line work in the North Eastern area. These engines follow the Great Central design, apart from some boiler fittings and longer valve travel. The two transferred to London are Nos. 1760 and 1766 which were actually constructed by Hawthorn, Leslie and Co. Ltd. Three of the G.N. type Gresley "N2" superheated 0-6-2Ts, Nos. 897, 4612 and 4763, have also been on trial over the comparatively long runs from Marylebone.

The first "C7" "Atlantic" of standard type to be withdrawn is No. 2170. The engines of this class are

the large N.E.R. 3-cyl. "Atlantics" built between 1911 and 1918 to the design of Sir Vincent Raven, having three sets of link motion between the frames actuating piston valves. The three cylinders are 16½ in. in diameter with a 26 in. stroke, and boiler pressure is 175 lb. per sq. in. The boiler is longer than on the Great Northern big "Atlantics," but does not contain so great a tubal or combined heating surface and the grate area is less; the firebox is much deeper, but narrower. The driving wheels are rather large, of the unusual diameter of 6 ft. 10 in. Of the earlier two-cylinder N.E.R. 4-4-2 express series, L.N.E. class "C6," No. 649 is another to be scrapped. Before the coming of "Pacifics" in large numbers these North Eastern "Atlantics" played a leading part in the haulage of the East Coast expresses between York and Edinburgh.

Two curious instances were recently noted near Grantham on the main line from Peterborough of "Pacific" and 0-6-0 engines running "light" coupled together. No. 2744 "*Grand Parade*" of type "A3" was attached to No. 3074, of "J2" class, and "A1" No. 2548 "*Galtee More*" to "J39" No. 1974.

New Locomotives for the Canadian National Railways

No. 6235, the first of 30 new "6200" class 4-8-4 locomotives, was recently delivered to the Canadian National Railways from the Longue Pointe shops of the Montreal Locomotive Works, being formally taken over and inspected by the Chairman and President of the C.N.R. These engines are for mixed traffic and, as in the case of the first "6200" series, they will be equally suited for passenger trains or fast long-distance freight work. The dome is enclosed in one casing with the sandbox, as is now frequently the practice overseas; in this case the external mountings are neat and material has been economised. These engines and tenders are 94 ft. 9 in. long and the big bogie tenders have a capacity of 11,600 gall. of water as well as 18 tons of coal.

The bells carried on the front of the engines in accordance with invariable practice in the Dominion are made of steel plate as a wartime measure; they are usually of bronze, but war priorities have rendered that metal scarce.

On the G.W. main line one Sunday a short time ago L.N.E.R. No. 3283, an ex-G.N. "Atlantic," was working the through Sheffield-Swindon and back train between Oxford and Didcot West. The next train that passed was hauled by G.W.R. small 4-4-0 No. 3283, this being a local goods from Didcot!

The Wainwright "C" Class

The sturdy "C" class 0-6-0 engines have been familiar for 40 years all over what is now the Eastern section of the S.R. The first example of the type was built in 1900 for the South Eastern and Chatham Joint Committee, as it then was, to the design of Mr. Harry Wainwright. The first batches were turned out by two of the firms now forming part of the North British Locomotive Co. Ltd., Glasgow; later ones were constructed at Ashford (Kent), and at the Longhedge Works, Battersea, London, which were at one time the locomotive headquarters of the former London, Chatham and Dover Railway, but have long since ceased to be used for engine buildings. Eight years later 108 had been put into service. They are all still on the active list in practically unaltered form, being decidedly the most numerous class of 0-6-0s on the Southern system. They are numbered variously from 1004 to 1725, having had "1000" added to their original S.E.C.R. numbers under the group scheme in order to avoid confusion with former London and Southern Western locomotives carrying similar numbers.

The "C" class engines have long been the "maids of all work" in Kent. During the first world war they rendered invaluable service with heavy freight and military trains and they are still playing their part to a more local extent to-day. Until there were sufficient "U1" 3-cylinder 2-6-0s available, "Cs" were seen regularly in summer hauling through

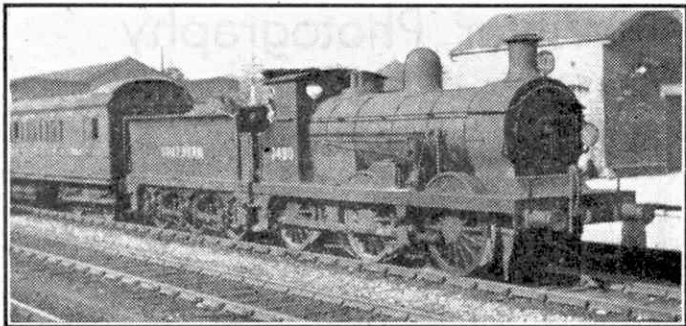

S.R. "C" class 0-6-0 No. 1480. The story of this class is told on this page. Photograph by G. O. P. Pearce.

is 4 ft. 7 in. in diameter and is rather high-pitched; steam pressure is only 160 lb. per sq. in., but the locomotives will stand being driven hard, and they often are!

Our illustration shows one in latest S.R. finish working a main line empty stock train.

New Canadian 2-8-2 Type on the C.P.R.

Nos. 5417-36, of class "P2h," were completed early this year by the Canadian Locomotive Co. Ltd. for the Canadian Pacific Railway. These are very useful two-cylinder goods engines for main-line work. They incorporate a considerable amount of Canadian-made steel plate, thus saving shipping space. There is a wide fire-box with a short combustion chamber; water top-feed and feed-water heater are mounted outside the boiler, and the running plate is high above the coupled wheels, which are 5 ft. 3 in. diameter. The outside cylinders are of greater size than would be practicable in this country, having a diameter of 22 in. with a 32 in. stroke. Working pressure is 275 lb. per sq. in. and the total evaporative heating surface is 3,436 sq. ft., with no less than 970 ft. superheater area in addition. Leading and trailing wheels have outside bearings; the former are 2 ft. 9 in. and the latter 3 ft. 9 in. in diameter.

Equipment includes Walschaerts gear, mechanical stoker, air compressor, electric lighting generator and hydrostatic and force-feed lubricators. The tender is carried on two four-wheeled bogies with 3 ft. wheels and a wheel base of 26 ft. 4 in. Its capacity is 10,000 Imperial gallons, with 18 tons of coal.

American Bogie Tank Wagons Here

A number of American 40-ton "tank-cars" have been shipped across the Atlantic in parts and fitted together in works adjacent to the G.W.R.

system. They are intended for war service in Europe. The cylindrical tanks have a capacity of 9,900 gallons. The vehicles have a total length over buffers of nearly 41 ft., and they are carried on two four-wheeled bogies, so that they are of decidedly unusual appearance to British eyes. Bogie freight vehicles of any kind are comparatively unusual here.

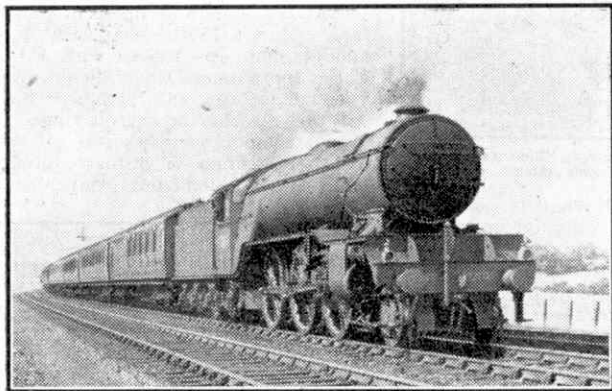

L.N.E.R. Doncaster—King's Cross express hauled by "V2" No. 4801. Photograph by C. R. L. Coles.

passenger trains over the steeply-graded North Kent main line between London and Ramsgate, although their driving wheels are only 5 ft. 2 in. diameter. Such duties on busy Saturdays even included hauling corridor Pullman car express from Victoria to Whitstable and beyond.

The inside cylinders of the "C" class engines are 18½ in. diameter with a 26 in. stroke. The boiler

Winter Photography

By A.R.P.S.

JANUARY is the month when we can expect winter conditions, snow, frost and ice, to be present, but really pictorial subjects in these conditions are not easy to find. It is a good plan to make notes in advance of suitable places for photographing when they are covered with snow.

I have no regard for a snow scene without a spot of sunshine and nice shadows. But that beautiful texture in

with shadows caused by fitful bursts of sunshine.

Frost will help, not only with regard to snow scenes, but also with "close-ups." In the early morning after a

night's frost some very beautiful pictures may be got of hoar frost on bushes and twigs and sometimes on spiders' webs. For this kind of photography I have found a focussing cloth, or any piece of dark material, very useful as a background. Such a cloth is valuable also in taking pictures of frost patterns on windows.

For most winter photography I do not think anything is to be gained by using very fast films. The main factor is to be able to gauge the exposure, and this obviously must be determined by the amount of space covered by snow because of the light reflected from it. I suggest that for ordinary open subjects you should try with any make of extra rapid film 1/150th sec. with F.8 and for close-ups 1/50th with F.11. These approximate times should give you fair results and possibly they will prove to be the correct times.

In developing aim for soft negatives and use medium or ordinary grade papers for making your prints.

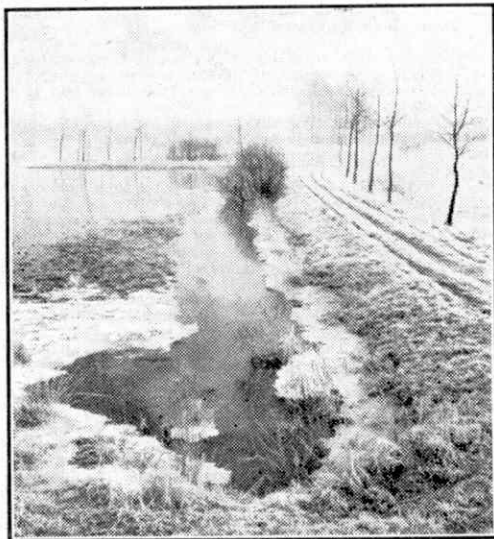

A Winter Scene. The upper photograph, "Look out!," is by S. S. Pethybridge, Newton Abbot.

the snow when it is fresh that is so essential in our prints can only be obtained by correctly exposing and developing. What are we to look for when out for snow pictures? Heavy or hard contrasts must be avoided, and there must be objects for half-tones such as thin open hedges or a cottage or farm building that will photograph grey. A haystack is good and so are elm trees or the silver birches. These of course are only details in the setting for the purpose of breaking up the contrasts. A good sized ditch, a farm track, a pathway through the trees, the bank of a pond, or an unpaved road leading to a church or cottage form very good main objects, as the snow will be found usually in uneven surfaces on such,



A Swan Conference.

From Our Readers

This page is reserved for articles from our readers. Contributions not exceeding 500 words in length are invited on any subject of which the writer has special knowledge or experience. These should be written neatly on one side of the paper only, and should be accompanied if possible by original photographs for use as illustrations. Articles published will be paid for. Statements in articles submitted are accepted as being sent in good faith, but the Editor takes no responsibility for their accuracy.

L.M.S. 5 ft. 3 in. GAUGE LOCOMOTIVES

In 1903 the Midland Railway took over the Belfast and Northern Counties Railway, with the result that the L.M.S. now possess a stock of engines of 5 ft. 3 in.

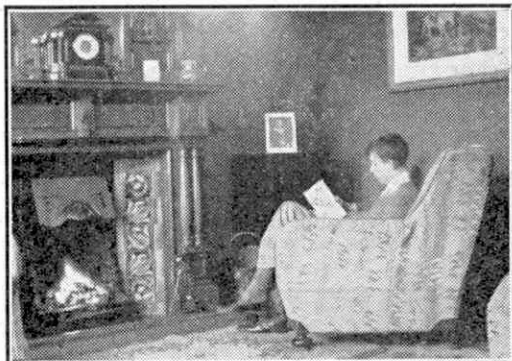

An indoor portrait for which the sitter himself made the necessary exposure, as explained on this page. Photograph by J. D. Wilson, Blundellsands.

gauge running on this line in Northern Ireland. Of these, the chief are the 2-6-0 "Moguls," one of which is shown in the lower illustration on this page. These mixed traffic engines have 19 in. by 26 in. cylinders and 6 ft. driving wheels. They are 15 in number; the first four, Nos. 90 to 93, were built at Derby in 1933, and Nos. 94 to 104 were built at Belfast. With the exception of Nos. 101, 102 and 104, all are named. Nos. 90 to 93 have recently been equipped with new boilers. In pre-war days these engines hauled "The North Atlantic Express" covering the 65½ miles between Belfast and Portrush in 80 min.

The other principal locomotives on this line are of the 4-4-0 type, with 6 ft. driving wheels and 19 in. by 24 in. cylinders.

In addition to the standard gauge lines there is a branch line of 3 ft. gauge running from Ballymoney to Ballycastle; this line is worked by tank engines of the 2-4-2 and 4-4-2 types.

W. P. McCORMICK (Belfast).

A SELF PORTRAIT

The accompanying photograph is rather an extraordinary one. It is of myself reading, yet I opened the shutter before I sat down and then after the exposure I got up and closed the shutter.

The photograph is not blurred. It was taken on a rainy day just after New Year's Day of 1943. The only light was that from two lamps, one of 60 and the other of 100 watts, and the exposure was 1 minute.

The camera I used is one I had found in a drawer in several pieces and had repaired. It is a 2A Brownie, model B, dated 1916. The film was a Sclochrome—and this also was of an old kind, the

date of expiration marked on it being October, 1939.

J. D. WILSON (Blundellsands).

A REOPENED G.W.R. BRANCH LINE

The G.W.R. branch line from Plymouth to Yealmpton was opened some 50 years ago, and it was operated for many years as the only means of transport between the two places. In those days prospective passengers from Newton Ferrers, a village two or three miles from the line, had first to travel by ferry up an estuary to Steerpoint, a halt two miles from Yealmpton, in the hope of catching the train there. The ferry often had to wait for the tide to rise before it could get near enough to the shore for the passengers to land, which meant waiting for the next train.

With the institution of a bus service, the passenger service was closed down, and traffic on the line was confined to a solitary goods train once a week, carrying chiefly bricks from a works at Steerpoint, though an unofficial load once witnessed was of peasticks stacked up round the engine! A passenger service is now again operated by a railcar unit that makes eight journeys in each direction every day. The speed is not exactly enormous, the journey of 7½ miles being made in 27 min. but this is quite good, as in that short distance there are four separate stretches of 1 in 60!

At one point there is a gradient post of which one arm is level, while the other bears the figures "68.17." Can any reader tell me what this means? Another interesting feature that I have noticed is a set of railings at Yealmpton made of the "Bridge Rails" designed by Brunel for the original G.W.R. In cross section these were shaped like a shallow arch. They were secured to hardwood planks, and fixed directly to the sleepers. On Brunel's original G.W.R. track the sleepers were not laid across the track, as they are on all railways to-day, but along it, under the rails, with cross-ties at the ends of the sleepers. Piles were driven into the ground to provide support for the track, but this elaborate system proved unsuitable.

R. B. BENSTED-SMITH (Newton Ferrers).

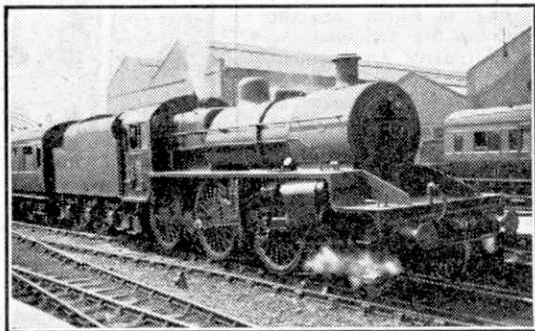

A "Mogul" of the L.M.S. Northern Counties Committee line of 5 ft. 3 in. gauge. Photograph by W. P. McCormick, Knock, Belfast.

Suggestions Section

By "Spanner"

(626) A Novel Bevel and Contrate Reduction Gear (T. Griffiths, Bristol)

Fig. 626 shows an interesting and novel method of using Bevel, Contrate and Pinion Gears in constructing a reduction gear that has been suggested by T. Griffiths, Bristol. The mechanism is essentially an epicyclic gear and gives various ratios according to the manner in which it is driven. The general construction is clear from the illustration. The axle Rod 1 carries a $\frac{1}{2}'' \times \frac{1}{2}''$ Pinion 2 that is fixed to it, and a Double Arm Crank that is free on the Rod. The Crank has attached to it a $1\frac{1}{2}'' \times 1\frac{1}{2}''$ Double Angle Strip and is retained in position between two Collars. An Obtuse Angle Bracket 3 at each end of the Double Angle Strip carries a $\frac{3}{4}''$ Contrate Wheel which is free to rotate. The two Contrate Wheels are so arranged that they mesh with the Pinion 2 and also with a $1\frac{1}{2}''$ Contrate Wheel mounted on Rod 1.

To use the mechanism as a reduction gear the Contrate 4 can be secured to the Rod to prevent it from rotating, and the Rod driven from the power unit. The drive is then taken from the Double Arm Crank of the frame by means of a Socket Coupling, in which case the Collar 5 is removed. An alternative arrangement is to secure the cage and drive between the Rod 1 and Contrate Wheel 4.

An alternative and, I think, a better method, of constructing this mechanism is to use two $\frac{3}{4}''$ Bevel Wheels in place of the $\frac{3}{4}''$ Contrates and a Small Bevel Gear, Part No. 30a, in place of the $\frac{1}{2}'' \times \frac{1}{2}''$ Pinion.

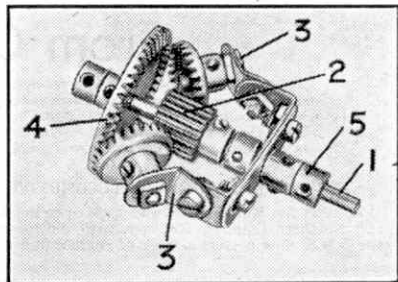

Fig. 626

(627) Simplified Clock Escapement ("Spanner")

Meccano clocks are always popular subjects with model-builders, who are continually experimenting and trying out new ideas for their construction. Among the various mechanisms that are included in a pendulum-type clock is an escapement device, and a very neat and simple method

of building up such a device is shown in Fig. 627. The escapement wheel in this is a 2" Sprocket Gear, which would normally be mounted on the final drive shaft of the clock gear train. Working in conjunction with this Sprocket is a pallet, which consists of a $1\frac{1}{2}'' \times \frac{1}{2}''$ Double Angle Strip to which is bolted a Double Bracket. To each arm of the Double Bracket is bolted a Crank, as shown, and the Cranks are locked on the ends of two short Rods. The other ends of the Rods are carried in suitable bearings, but only one bearing is shown in the illustration in order to make the construction clear. When fitting the Cranks, great care should be taken to see that they are exactly in alignment, and care also must be taken in adjusting the ends of the Double Angle Strips in relation to the teeth of the Sprocket Wheel.

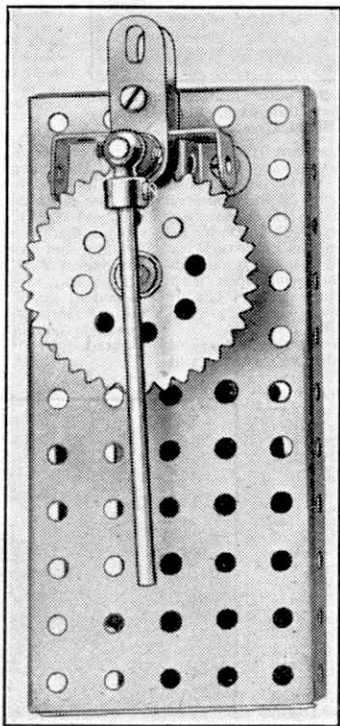

Fig. 627

The pendulum rod should be fixed to the outer short Rod of the pallet by means of a coupling or a Hand-rail Support as shown.

An advantage of this type of escapement over some others is its compactness. It is smooth and silent in operation, and absorbs very little of the driving power.

(628) Internal Front Wheel Expanding Brake ("Spanner")

In the design of brake mechanisms for the front wheels of vehicles it is essential to keep the distance between the road wheels and the stub axle supports as short as possible.

In designing the interesting Meccano brake device shown in Fig. 628 this point has been kept in mind. It will be seen that the stub axle pivot 1, which is journalled freely in the two portions of the front axle, has mounted on it a Coupling that carries the stub axle. The latter has fixed to it a Face Plate, in the opposite holes of which $\frac{1}{2}$ " Bolts 2 are free to slide. Two Washers are placed under the heads of each Bolt, before inserting them in the slots, and Collars are secured on the shanks of the Bolts. The Collars form the brake shoes, and a short length of Spring Cord is attached to their set-screws to keep them in contact with the cam 3, by means of which they are actuated.

The cam 3 consists of two small radius Curved Strips bolted to a $2\frac{1}{2}$ " Strip.

(629) Screw Jack ("Spanner")

The simple jack mechanism shown in Fig. 629 is a miniature reproduction of a typical motor car screw jack. The base of the device consists of a Flat Trunnion to which a Threaded Coupling is secured rigidly, with its tapped hole uppermost. A Cranked Bent Strip also is secured to the Flat Trunnion, as indicated in the illustration, and this serves as a bearing for a short Rod carrying a Universal Coupling at one end with a $\frac{3}{4}$ " Contrate Wheel at the other.

An Axle Rod is secured in the remaining portion of the Universal Coupling, and its upper end is fitted with a handle consisting of a Collar having two

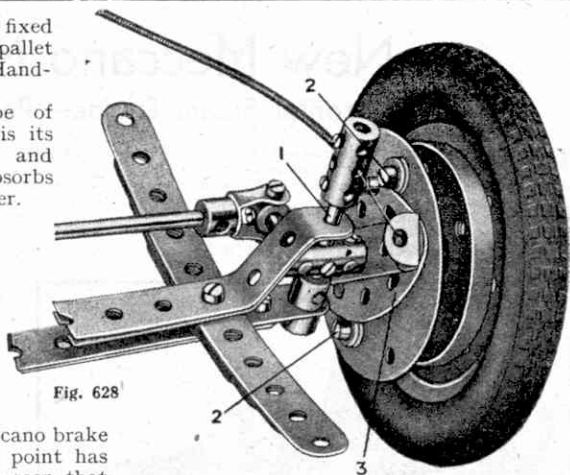

Fig. 628

Threaded Pins screwed into its tapped holes. The $\frac{3}{4}$ " Contrate Wheel meshes with a $\frac{1}{2}$ " diam. $\frac{1}{2}$ " face Pinion secured on a Screwed Rod, 2" in length. The Screwed Rod works in the threaded bore of the Coupling and the jack is raised or lowered by rotating the Contrate Wheel.

(630) A Note on Lubrication ("Spanner")

Many Meccano model-builders are inclined to overlook the necessity for lubricating their models. It should be remembered that most of these models run at comparatively high speeds, and adequate oiling is necessary to prevent the bearings from wearing.

Meccano Lubricating Oil is specially provided for this purpose and is of the proper consistency for both models and Motors. It should always be used when possible, but if a supply is not available the oil that is used for sewing machines and typewriters forms the best substitute. On no account should a thicker oil be used, and in oiling an Electric Motor it is important to see that only a very slight amount is applied; otherwise the oil will be certain to be flung on to the commutator segments and brushes, where its presence will give rise to loss of efficiency.

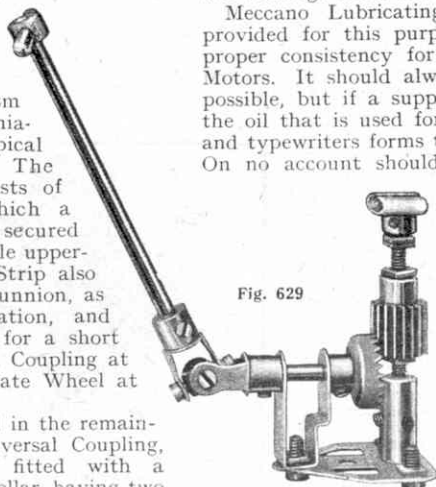

Fig. 629

New Meccano Models

Horizontal Steam Engine—Potato Digger

THE horizontal steam engine shown in Fig. 1 is a splendid model that works most realistically when set in motion by means of a Meccano Clockwork or Electric Motor.

The bedplate of the engine is simply constructed. It consists of four $12\frac{1}{2}$ " Strips spaced apart by two $2\frac{1}{2}$ " \times $2\frac{1}{2}$ " Flat Plates and two $5\frac{1}{2}$ " \times $2\frac{1}{2}$ " Flat Plates 2.

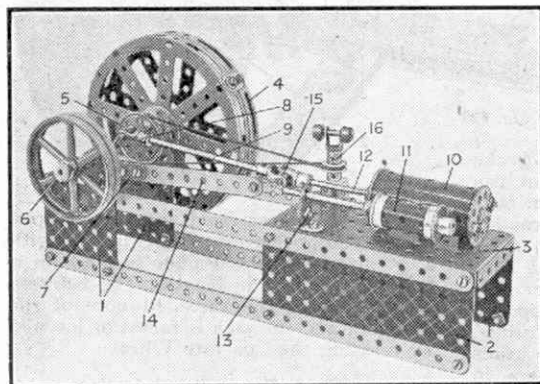

Fig. 1. An attractive working model of a horizontal steam engine that is easy to build.

These form the sides, which are then bolted to a $5\frac{1}{2}$ " \times $2\frac{1}{2}$ " Flanged Plate 3 and spaced apart at the opposite end by two $2\frac{1}{2}$ " \times $1\frac{1}{2}$ " Double Angle Strips.

Bearings for the Crankshaft, Part No. 134, are formed by Flat Trunnions bolted to the upper $12\frac{1}{2}$ " Strips. The Crankshaft carries a built-up flywheel 4, consisting of two Flat Discs connected together by Flat Brackets, and a $2\frac{1}{2}$ " Pulley 5, a Flywheel 6 and an Eccentric 7. Also on the Crankshaft is a Small Fork Piece 8 to which the connecting rod 9 is fixed.

The steam cylinder 10 is a $2\frac{1}{2}$ " Cylinder fitted with end covers consisting of Bush Wheels held in place by nuts on two Screwed Rods passed through the Cylinders. The valve chest 11 is a Sleeve Piece bolted to the Cylinder end fitted at each end with a $\frac{1}{2}$ " dia. Flanged Wheel.

A $1\frac{1}{2}$ " \times $1\frac{1}{2}$ " Angle Bracket 13 is bolted to the Flanged Plate to form a guide bearing for the valve rod, which carries at its outer end a Rod and Strip Connector that is pivotally connected by a lock-nutted bolt to a $4\frac{1}{2}$ " Strip 14. The other end of this Strip is bolted rigidly to the arm of the Eccentric 7. The piston rod 12 carries a Universal Coupling, the other boss of which is fixed to the connecting rod 9. The other end of the connecting rod is held in the boss of the Small Fork Piece 8.

A short rod journalled in a Double Bent Strip bolted to the Flanged Plate carries a $\frac{1}{2}$ " Pulley and a Small Fork Piece 16. The Rod itself is held in place by a Collar below the Flanged Plate, and the Fork Piece carries in its arms a $1\frac{1}{2}$ " Rod, fitted at each end with a Collar. This unit forms a realistic speed governor, and it is rotated by means of a Driving Band passed round the $\frac{1}{2}$ " Pulley and the $2\frac{1}{2}$ " Pulley on the

Crankshaft.

If a Clockwork or an Electric Motor is available it may be used to drive the model; the driving pulley of the motor should be connected by a Driving Band to the Flywheel 6. Before setting the engine in motion a little oil should be applied to the bearings, and also to the piston and valve rods so as to ensure their easy movement.

Parts required to build model Horizontal Steam Engine: 4 of No. 1; 1 of No. 9a; 3 of No. 10; 1 of No. 12B; 1 of No. 15a; 1 of No. 15b; 1 of No. 16b; 1 of No. 18b; 2 of No. 20b; 1 of No. 21; 1 of No. 23a; 3 of No. 24; 32 of No. 37a; 14 of No. 37b; 1 of No. 45; 1 of No. 52; 4 of No. 59; 2 of No. 70; 2 of No. 72; 2 of No. 111; 1 of No. 116a; 2 of No. 118; 2 of No. 126a; 1 of No. 132; 1 of No. 134; 1 of No. 140; 1 of No. 163; 1 of No. 170; 1 of No. 212; 1 of No. 216.

Our other new model this month is a novel type of agricultural machine known as a potato digger. It is shown in Fig. 2. The chassis of the model consists of a $2\frac{1}{2}$ " \times $1\frac{1}{2}$ " Double Angle Strip, the arms of which are extended by Strips, as shown. A $2\frac{1}{2}$ " \times $1\frac{1}{2}$ " Double Angle Strip bridges the U-shaped frame so formed. The road wheels are mounted on a Rod journalled in the front end holes of the Strips, and this Rod carries also a $\frac{1}{2}$ " Contrate Wheel 1 that meshes with a $\frac{1}{2}$ " Pinion 2 on the Rod that carries the digger 3.

The driver's seat is a Trunnion bolted to a Swivel Bearing, which in turn is fixed to a Double Bent Strip. A $2\frac{1}{2}$ " Strip 4 is bolted to one side of the chassis and carries in its lower end hole a $\frac{1}{2}$ " loose Pulley. The $2\frac{1}{2}$ " Strip is linked by a second short Strip to a pivoted lever 5. By moving this lever to and fro the digger can be raised from or lowered to the ground. A Flat Bracket 6 forms a stop to prevent the $2\frac{1}{2}$ " Strip from going beyond the vertical position.

Parts required to build model Potato Digger: 1 of No. 4; 3 of No. 5; 1 of No. 6; 1 of No. 10; 1 of No. 15; 2 of No. 16; 2 of No. 19b; 1 of No. 23; 1 of No. 24; 1 of No. 26; 1 of No. 28; 2 of No. 35; 24 of No. 37a; 19 of No. 37b; 1 of No. 45; 1 of No. 47; 3 of No. 48a; 1 of No. 51; 1 of No. 111; 1 of No. 115; 1 of No. 116; 1 of No. 126; 2 of No. 142; 1 of No. 165.

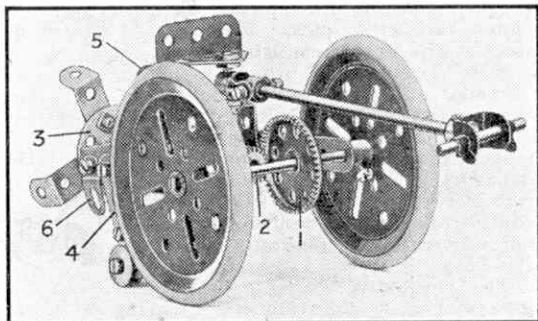

Fig. 2. The mechanism of this potato digger includes some very interesting movements.

Meccano Model-Building Competitions

By "Spanner"

A Grand New Year Model-Building Contest

Even in wartime this is the season of the year when model-builders are busiest, planning new models and devoting all their leisure time to construction. This applies to experienced model-builders and beginners alike, and for this reason we think it a good time to introduce a great general model-building competition, one in which all can take part, young and old, veterans and novices, with a good chance of winning one of the many fine cheques or Postal Orders that are offered.

In order to give every entrant a chance to show his best work no restriction whatever is being placed on the subjects of models submitted in this competition. These may be cranes, motor cars or lorries, or machines with ingenious mechanisms, or simple structures of an architectural kind, with no movement at all. Although full credit will be given to large and complicated models, it must be emphasised that these are not at all essential. What the judges will look for is skill in design and in the use of Meccano Parts, and soundness in construction. If desired a group of models may be submitted, but they will be regarded as a single entry.

Preparing an entry for this contest is very easy. The model itself is not required, all that should be sent being a photograph or drawing, with any notes required to explain special constructional features. On the back of each photograph or drawing sent in the competitor must write his name, address and age, and his entry should be forwarded to "1944 New Year Model-Building Contest, Meccano Limited, Binns Road, Liverpool 13."

Entries will be divided into two sections according to the ages of competitors. Those from readers of 14 years of age or more will be placed in Section A, and those from competitors under 14 will be grouped together in Section B. The Contest will remain open for entries until 31st March.

The following prizes will be awarded in each Section of the Contest to the builders of the most interesting models received. First, Cheque for £2/2/-. Second and Third prizes will consist respectively of cheques

for £1/1/- and 10/6. There will be also five further prizes, each consisting of a Postal Order for 5/-, and Certificates of Merit will be awarded to competitors whose models fall just short of prize-winning standard.

I shall look forward to a very fine entry in this contest, in which entrants are being given plenty of time to design and build their models and to prepare the necessary photographs or drawings.

COMPETITION RESULTS

September Model Judging Contest (Home Section)

In the September, 1943, issue of the "M.M." we gave details of a novel competition in which competitors were asked to select which one of seven simple models they thought the best, and then arrange the seven models in the order in which they thought the masses would vote of all competitors would place them. In addition, competitors were asked to suggest three new subjects for future model-building contests.

The seven models that formed the subject of the contest appeared in the "M.M." between July and September last year. No competitor succeeded in placing the seven models in the exact order in which they were placed by the combined votes of all competitors, and the prizes therefore were awarded to those competitors whose entries forecast the result most nearly.

The actual order in which the models were placed is: 1, Tricycle; 2, Army Mule; 3, Mobile Crane; 4, Watch Stand; 5, Aerial Flyer; 6, Swing Boat; 7, High Jump. The list of prize-winners is as follows:

1st Prize, Cheque for £2/2/-: P. I. Addison, Navenby; 2nd, Cheque for £1/1/-: T. Fogden, Tunbridge Wells; 3rd, Postal Order for 10/6: E. G. Smith, Manchester. Postal Orders for 5/-: J. Bass, Leicester; W. Whitaker, Dewsbury.

Many of the suggestions for new competitions which were submitted with the prize-winning entries were most interesting, and contests based on some of the most suitable of these ideas will be arranged from time to time as opportunity allows.

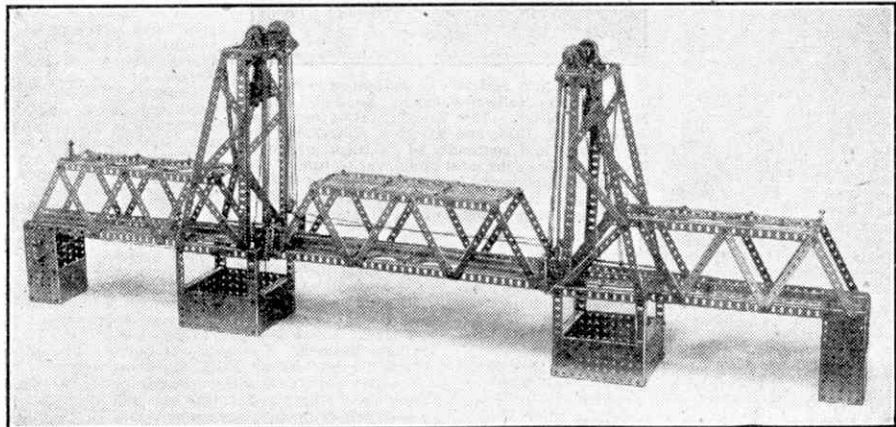

A plainly constructed and realistic model of a famous lifting bridge in Holland. It was built by W. van der Brock, Utrecht, Holland, before the war.



Club and Branch News



WITH THE SECRETARY

BEST WISHES FOR THE NEW YEAR

To all Guild and H.R.C. members I send New Year greetings, with wishes for a happy and prosperous time for each one of them in 1944. Last year I wrote that we could then see at last a certainty of victory within a reasonable time. The outlook is even brighter this year, and we can have confidence that it will not be long before the cause of the United Nations triumphs. We must not forget those of our members who are actively engaged in the fight, and I know that all at home will join in greetings to them, wherever they may be.

CLUB MODEL-BUILDING

It is astonishing to realise how efficiently model-building is being carried on in all active Clubs, when the difficulties caused by the cessation of supplies are taken into account. Clubs in which a good stock of parts had been accumulated are now reaping the benefit of their foresight. In other Clubs the construction by groups of members of large and attractive models may no longer be possible, but good fun can still be enjoyed if a little thought is applied to the form that Model-building Competitions and construction efforts generally are given. "Simplicity" Contests are familiar to all Leaders and now is the time to make good use of them, and so to encourage the development of ingenuity and resource in making the most of somewhat limited resources. In other competitions the subjects chosen can be such as to encourage the construction of small models, with ingenious movements or distinguished by original and realistic use of only a few of the more common parts, such as Strips and Plates. Nuts and Bolts offer perhaps the chief difficulty; if these are not available in sufficient quantity the small bolts and nuts used in small electrical gadgets are the best substitute, and it is better to have them in models than to have no models at all.

MERIT MEDALLIONS FOR 1943

I am now completing my 1943 list of Merit Medallions for publication next month. There is still time for Leaders who have not sent in nominations to do so, and I hope that those who wish to have Merit Medallions awarded for good work performed by any of their members during the past Session will let me have the names of the winners at once.

CLUB NOTES

PLYMOUTH M.C.—On one evening the Club received a visit from members of the Christ Church Boys Club. Cinematograph Shows continue and talks on Woodwork are being given. The Printing Section is producing Club literature. Good scenery is being provided for the Hornby-Dublo layout, and steady progress is being made with the Gauge 0 Railway. Club roll: 94. *Secretary:* S. Finmore, 5, Mutley Plain, Plymouth.

Navenby M.C.—A new feature is Carpentry Night, held weekly, for which Rev. L. T. S. Barratt, Leader, has kindly provided facilities. Members have repaired

toboggans, for use when snow comes. The Club's first birthday was celebrated by a Lantern Lecture, given at an open meeting, when a collection realised 9/- for Club funds. A Library is being formed. Club roll: 19. *Secretary:* P. I. Addison, High Street, Navenby, Lincoln.

BRANCH NEWS

THREE BRIDGES—Excellent plans have been made for operations during the present indoor sessions. The official positions to be occupied by members have been settled, and an engine head code and a bell call system for communication have been introduced. Details of orders to be followed at track meetings are laid down in the "Stock Book" and the "Running Book." Members work splendidly together and operations on the line are really good fun. *Secretary:* O. J. Baldwin, 27, St. Mary's Drive, Three Bridges, Sussex.

CANFORD MAGNA—The track laid down in the Club room is well provided with stations, sidings, etc., and running operations are being greatly enjoyed; each member being given a position where strict attention to business is required. Extra meetings are being

arranged. *Secretary:* R. M. Jellis, 1, Broadway Court, Broadstone, Dorset.

WARNHAM—A timetable has now been worked out and put into operation. Realistic scenery has been laid down, and greatly improved the appearance of the track. Visits are being exchanged with the Three Bridges Branch. *Secretary:* S. Delves Broughton, Home Farm, Pondtail Road, Horsham, Sussex.

LOUGHTON—Attendances at meetings are excellent. Throughout the summer members met regularly for games outdoors and for indoor work in the Club room. The Forces have now claimed 11 members. *Secretary:* L. F. A. Smith, 38, Meadow Road, Loughton, Essex.



L. F. A. Smith is Secretary of the Loughton Branch of the Hornby Railway Company, No. 360, Leader, Mr. E. T. Driver. This Branch was incorporated in November, 1939, and has been remarkable for the interest and continuity of its track meetings, which have been the most prominent feature of the programmes followed. In addition Meccano Model-building has been carried on and outdoor games have been enjoyed whenever possible.

A Hornby Railway Miscellany

IN the layout and operation of a successful miniature railway system there are many points that are given attention almost automatically by the older enthusiast simply because he is experienced. For the benefit of younger readers we now deal with a few of these points.

With regard to the actual layout, the space available usually governs the character of the line. A common fault in laying down a line, whether it is a temporary one to be put away when operations are over, or a permanent system, is that there often appears to be too much actual railway! This may sound silly at first, but the point is that little bits of space here and there are filled up with odd sidings that have no real purpose. On the whole it is usually

and the bogie stock, it is advisable that the vehicle should be one that we have fitted with die-cast wheels, otherwise we may have trouble on the curved stretches of line. Where both triplane wheeled and die-cast wheeled vans are in use we may consider the latter as suitable for express freight or passenger train working, just as applies in actual practice to those vehicles fitted with automatic brakes.

Another point in running concerns the use of two clockwork engines together, "double-heading" a train. The best combination of course is to have two engines of the same type or at least with the same pattern of mechanism. They will then keep "in step" satisfactorily and a good load will be taken smoothly over the usual length of run for the type of engine

employed. Where engines with different mechanisms have to be used it is advisable to let the faster engine of the two be the leader. Then there will be no over-running of the slower leading engine on curves such as can occur at times. Two engines with greatly differing lengths of run should not be used to double-head; uneven running results, and the journey will be disappointing, as the longer runner will be checked and perhaps stopped as the "works" of its partner run down.

Another engine running detail concerns speed. Shunting and backing movements are often spoiled by being carried out at too high a speed. This may cause derailments and similar troubles. Gentle handling of the controller is necessary

with electrically-driven engines. With clockwork ones it is far better to wind them up just sufficiently for the particular movement to be made, and then wind again for the next, than to wind up fully and then have to call out the breakdown train as a result! "Little and often" is a golden rule in this as in other matters, such as lubrication, and far greater realism and fun is obtained. Clockwork engines must be wound up in any case, so a few more times makes no very great difference! Patience and practice in these matters soon brings about good results in smooth and trouble-free running.

A good instance of careful planning and operation is seen in the railway that is run jointly by J. Blanchard and J. Dennison, both "M.M." readers, of Blandford, Dorset. This line operates principally during the summer holidays, being 'out of doors, and it includes a splendid "dock area," as it skirts a small artificial lake. One track is carried across the water by means of a Meccano vertical lift bridge. An "avoiding" line allows passenger trains to keep clear of the actual dock area, where there is an extensive marshalling yard in which import and export traffic is sorted out. Goods traffic on the water itself is carried by barges that are towed by a Hornby cabin-type Speed Boat. Another of these vessels is used to make passenger runs from end to end of the lake, thus providing virtually a ferry service. Good use is made of Dinky Toys personnel to people the waterfront and railway premises generally, and a special feature is made of the conveyance of actual loads both in the railway wagons and the barges. The railway in its rolling stock and locomotives represents the practice of the S.R.

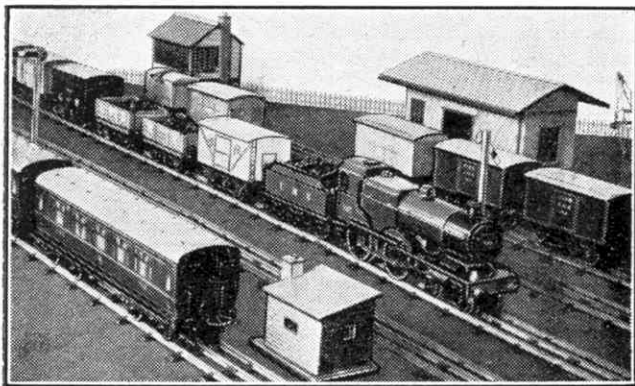

A mixed goods train on a Hornby layout. The engine is a No. 2 Special L.M.S. Standard Compound.

better to arrange the main line to run practically to the limits of our space, and to have our sidings and so on within the main oval, than to spread odd bits of line here and there outside the main track just to fill up space. A little less track and a little more attention to the use of accessories and lineside features can make a wonderful difference to the realism of a system.

It is of little use under present conditions to deal in detail with the use of the larger accessories such as Signals, Engine Sheds, Footbridges, and so on. On the whole it is fortunately the little things that make such a difference in the way of accessories — little gadgets for the lineside, the station platform, the goods loading bank and elsewhere. Miniature luggage and merchandise, boxes and barrels, platform machines, seats and fencing are all within the capacity of the average boy who is handy with his penknife. The advantages of Plasticine too make it specially suitable for this type of thing as Dublo enthusiasts will recall from previous articles in the "M.M." Many little oddments about the house can be made use of; small bottle corks make quite presentable milk churns, and from cartons and labels it is possible to make up quite a few realistic posters.

So much for the line and its looks; let us now turn our attention to the operating side. Unsatisfactory running, even on a well-laid track, can be caused by the mixing of different types of vehicles in the same train. Bogie stock should be kept together for instance, and this specially applies to the heavier vehicles that have die-cast wheels. Such vehicles should for preference be at the head of a train. If we want to attach a four-wheeler between the engine

A Useful Dublo Two-Track System

THIS month our Hornby-Dublo layout incorporates two main tracks, as will be seen from the accompanying diagram. These can be used either as the up and down lines respectively of a double track system, or as independent routes used for traffic in either direction.

The system is specially adapted to the use of Dublo Isolating Rails, which are indicated in solid black in the diagram and lettered "X." If we have none of these Rails, or we are operating a clockwork layout, we shall have to use standard Straight Quarter Rails in their place. Then we shall have to make our own isolating arrangements on our electric line. There are no special features in either of the ovals that form the main tracks, but the method of using the left-hand Points that form a crossover between them should be noted. The curved branch of each of these Points is separated from the other by means of an Isolating Rail or a Straight Quarter Rail according to our particular arrangements. On a one-engine railway no isolating schemes are necessary, and the two tracks can be used as independent routes, for each has a Station.

Let us suppose that we have a passenger train composed of a Two-Coach Articulated Unit standing alongside the platform of the Main Line Station served by the inner track. Our engine, a standard 0-6-2 Tank, is in the yard, so we run it forward for the last stages of "preparation" by the "crew." Then out it goes on to the inner main line where a halt is made beyond the points; these are set, the engine is reversed, and run in an anti-clockwise direction until it comes round to the train. After a short pause it can begin a journey round the inner track this time of course in a clockwise direction.

We can make our train cover as many circuits as we wish, stopping as required at the Main Line Station. This same station has to change its identity

at each stop, but this is a well-known bit of "make believe!" At one stop we can assume the train has reached a junction where it requires to turn off the original route. This is easily arranged. The points forming the crossover are set and the train is diverted to the outer track; it can then carry on as before

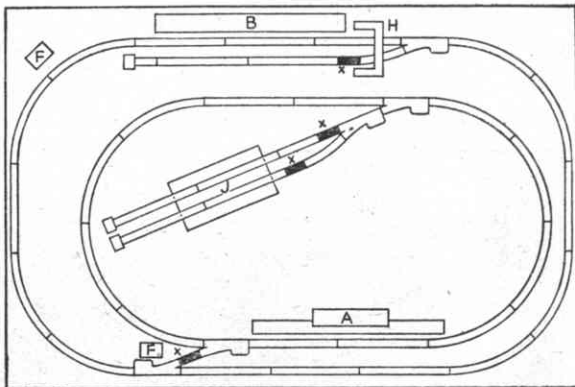

Key to the layout referred to on this page: A, Main Line Station; B, Island Platform; F, Signal Cabin; H, Footbridge; J, Engine Shed; X, Isolating Rails.

until it reaches its destination, stopping alongside the Island Platform on the upper side of the outer track.

Now we can shunt the train if we wish to, into the siding, and return the engine to the Shed. Alternatively the engine can run round the train by making a journey "light" round the complete outer circuit until it comes up to the other end of the train. A return to the starting point can then be made, the crossover points being set at a suitable moment to bring the train on to the inner circuit again.

If we have two engines, the second one can have been waiting on the longer of the two shed tracks, while the first train has been working its outward journey. On electric layouts the isolating arrangements make it possible to hold the ready-made-up train on the shed road while the other one is running. Once the first train has left the inner track and is continuing its journey, we can isolate the inner and outer circuits from one another, and can then have a train in operation on each track. This requires the use of Dublo Transformer No. 2, each separate output being connected with a Dublo Controller No. 1 to one of the tracks.

A point of importance in connection with the controlling arrangements where the one train is in motion as already described, concerns the passing of the train from one track to the other. As the engine passes from the influence of one Controller to that of the other it is necessary for the two Controller handles to be correctly adjusted so that the crossing is made smoothly. Both handles must be in the forward or reverse position according to the way the engine is running, or there will be trouble as soon as the engine bridges the gap between the two circuits. The winding up of the various items also must be made exactly as shown in the instruction leaflets.

With a Dublo No. 1 Transformer and a single Controller only one train can be in motion at once and it can be run from the inner to the outer circuits at will.

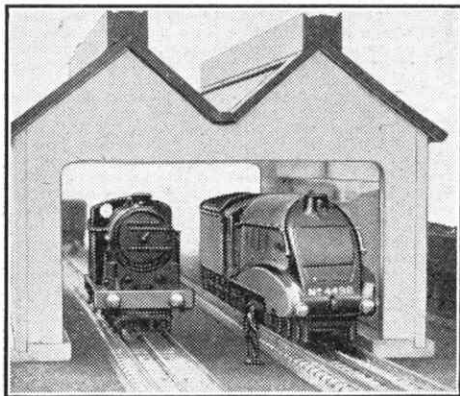

Dublo engine at the Shed before commencing a running programme.

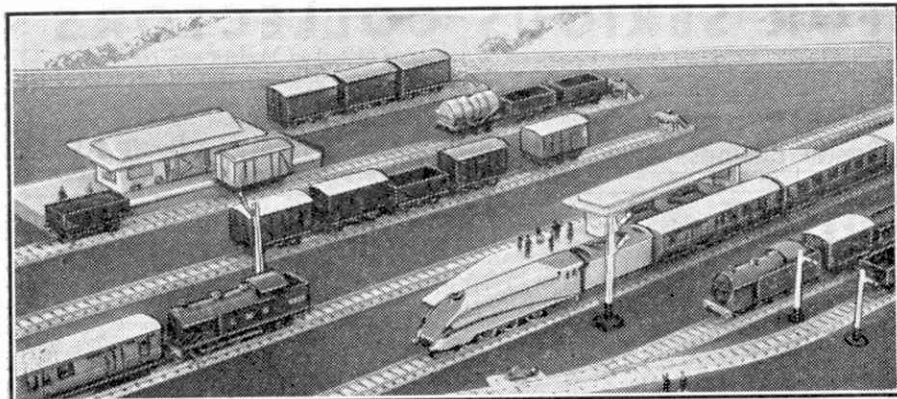

Dublo trains at work; note the L.M.S. engine with a train of L.N.E.R. stock as referred to in this article.

Some East Coast Trains in Dublo

THE L.N.E.R. main line from King's Cross to the north has long been a popular subject with model railway enthusiasts and Hornby-Dublo equipment is specially well adapted to the reproduction of the train working that is characteristic of it. With the Dublo passenger train components we can run practically any of the important L.N.E.R. expresses, except of course those such as "*The Silver Jubilee*," for which special vehicles were used. In any case this and the other streamlined "flyers" do not operate under present conditions. The Dublo Two-Coach Articulated Unit represents the real "twins" as they are often called. These, together with a main line coach such as the Dublo Corridor Coach D1, make up a standard formation employed in the composition of many of the real L.N.E.R. trains.

Remembering the well-known slogan "*King's Cross for Scotland*," we can have a great deal of fun working a miniature "*Flying Scotsman*" or some similar express between London and the north. The actual formation of the train will depend on exactly what stock we have available. If we are fortunate enough to possess a "twin" and a single Coach these will do quite nicely. A three-coach "set" makes a train of convenient length for most miniature stations.

With one three-coach "*Scotsman*," however, we can follow up the working stage by stage as we have shown previously on the run from, say, "*King's Cross*" to "*Aberdeen*." The engine of course should be the well-known streamline "*Sir Nigel Gresley*," a splendid "A4" in miniature, which will deal with our train just as capably as do its big relations in actual practice. Engine changing at various points can be carried out, if we have just the one express engine, by detaching the engine from the train and running it off to the Shed or engine siding. Here it can wait a moment or two and then can return to the train at the platform as if it were a fresh locomotive taking over for the next part of the run. This is the kind of "make believe" that often comes in useful in miniature operations!

If two engines are available, so much the better; one can relieve the other at suitable points on the journey. On electrically-operated layouts this type of working involves the use of several insulated sections of track so that the running of one engine does not interfere with the other. To form such sections the standard Isolating Rail and special Switch for it are most useful. Ingenious readers who do not

possess these items can, however, devise various substitute methods of getting the same results. On clockwork systems no special equipment is necessary; the locomotives need careful handling, however, to ensure that they make the various movements slowly, especially when backing on to the stationary train.

If our train is supposed to serve more than one destination, as the real "*Scotsmen*" do, then we shall have further interesting operations to perform at the stop representing "*Edinburgh*." Here the train can be divided; the main portion consisting of perhaps the Articulated Unit carrying on to "*Dundee*" and "*Aberdeen*," while the remaining part can make a separate journey to represent the working of the Glasgow section of the real train. For this, of course, it is preferable to have another engine, but the same engine can be used on each part of the train.

Similar methods can be applied to other services such as the important West Riding trains serving Leeds, Bradford, and so on. A little variety in working can be introduced here, Leeds being a terminal station. Our "*Bradford*" portion in miniature can consist of the single Corridor Coach D1 at the rear of the main or "*Leeds*" section. On arrival of the whole train at the stop representing "*Leeds*" a standard Dublo Tank engine can come on to the rear and work the "*Bradford*" coach away in the opposite direction. Actually the Dublo 0-6-2 Tank closely resembles the real Doncaster type of tank engines that are often used on this service.

Another duty with which these typical engines are particularly identified, and for which they were originally introduced, is the haulage of the London local services. For these again we must rely on the two-coach Unit, as it has not yet been possible to introduce proper suburban stock in the Dublo System. Articulated trains, however, are a feature of King's Cross suburban workings, so the use of our "twin" is quite reasonable. One point to notice here is that the local tank engines generally work bunker first to Town, and chimney first out into the country.

To these L.N.E.R. services may be added trains operated from the North London section of the L.M.S. to stations in the L.N.E.R. suburban area. Sometimes formed of L.N.E.R. stock nowadays, these are hauled by L.M.S. engines. So if we have an L.M.S. 0-6-2 Tank on a layout that is in other respects mostly L.N.E.R., here we have a realistic way of using it.

FOR SERIOUS COLLECTORS

Our Bargain "Discount" Approvals contain a fine range of picked Modern and New Issues, Pictorials, Comems., etc., from 1d.—6d. each, less a generous discount (**GENERAL SELECTIONS ONLY. NO SINGLE COUNTRIES OR G.B.**). Approvals or details are post free, and we do NOT send again unless requested. Br. Colonial or Mixed selections available, but no All-Foreign.

Postal Business Only **THE BIRKDALE STAMP CO. (P.T.S.)**
Dept. M, 104, Liverpool Road, Birkdale, Lancs.

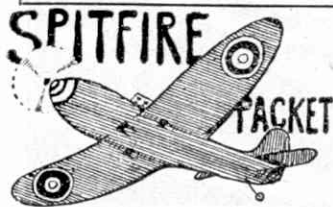

PACKET contains 33 air, triangular, and stamps with aeroplanes, etc.—2 LIBERIA triangular (with aeroplane; NIGERIA; F. OCEANIA; MOZAMBIQUE (Elephants); INDIA; 2 Canada; S. AFRICA (Pictorial); 2 TANGANYIKA; PALESTINE; 4 BRAZIL (aeroplane design, etc.); 5 U.S.A.; ICELAND (Fish); Australia; NEWFOUNDLAND; NEW CALEDONIA; CAMEROONS; ST. PIERRE; MOZAMBIQUE; (Pictorial); MADAGASCAR; THAILAND; CEYLON (Pictorial); EGYPT; BELGIUM (Lion) o.c. Price 51d., post 2d. extra. Applicants for approvals receive 6 Pictorial S. Africa and in addition, those sending addresses of stamp collecting friends get set of 4 JAMAICA. **BARGAINS**—100 B. Cols. 2/3; 12 Free French (Cols.) 7d.; 20 Rhodesia 1/6. ASK for LISTS 1d. **H. C. WATKINS (MM)**, Granville Road, BARNET

FREE TO ALL

collectors sending postage (3d.)
This Unique Triangular Health Stamp



G. P. KEEF, WILLINGDON, EASTBOURNE

THE FIRST STAMP EVER ISSUED

(British 1840 Penny Black) for P.O. 6/91 It is guaranteed genuine in every respect. (Better-grade copies also available at 9/6, 12/6 and 15/6 respectively). Its companion stamp (1840 2d. blue) nice used at 8/9 (better grade at 11/6, 14/6 and 17/6 respectively). Other "Classics" which every collector should have are the **CAPE OF GOOD HOPE TRIANGULARS**; we offer 1d. rose (cat. 42/6) at 15/-; 1d. brown-red (cat. 55/-) at 18/6; 4d. blue (cat. 17/6) at 6/9; 6d. pale lilac (cat. 42/-) at 15/-; 1/- yellow-green (cat. 80/-) at 26/9; 1/- deep dark green (cat. 85/-) at 28/6; and 1/- emerald-green (cat. 26) at 46/6; also **VICTORIA 1850-55 Half-Length Queen 1d.** (cat. to 70/-) at 10/- (fair) to 25/- (very fine); and 3d. (cat. to 50/-) at 7/6 (fair) to 17/6 (very fine); 1854-55 Queen on Throne 2d. (cat. to 25/-) at 5/- (fair) to 12/6 (very fine);

SUPERB APPROVALS (general, or by countries for really serious collectors and specialists) against approved English references or a deposit.

1943 price list, price 1d. post free.

NORRIS & CO. (Dept. M), SOMERCOTES, DERBY

APPROVAL BOOKS

containing low and medium priced Colonial and Foreign stamps still sent to applicants. Good discount and a list of 90 FREE GIFTS varying in value according to money sent for purchases. These gifts can be chosen by you from this list which contains King George VI, Jubilees, Free French, ALL the Coronation Sets Mint, etc. 3d. stamp please.

C. A. RUSH, 38, Queen's Avenue, Whetstone, London N.20

Catalogued 10d., 2/6, 6/-—penny each! Approval, 3d. postage please. J. Baguley, 133, Woodstock Avenue, London N.W.11.

For other Stamp Advertisements see pages 32 and viii.

K.G.VI MINT

Our APPROVAL BOOKS contain almost the entire range of Current Mint Colonials from Aden to Virgin Is., in sets to 3d. or to 1/-, with nearly all stamps priced separately. Postage is paid each way and discount given. Other attractive stamps are also included. A postcard will bring the first selection, and others will be sent at intervals of your own choosing.

GEM STAMP CO. - TADWORTH - SURREY

FREE—STAMPS CATALOGUED 5/-

to applicants for 3d. approvals.

COX, 17, STONELEIGH PARK ROAD, EWELL

DUTCH ROYAL FAMILY PKT. FREE!



This beautiful stamp just issued by CURACAO depicts Queen Wilhelmina of the Netherlands, her Daughter and Husband, and the Royal Children. Three Generations on one stamp. It is included in this excellent packet of all different stamps from British Colonies, unused issues, U.S.A., old French, Australia (K.G.VI), Bohemia, and many others which space does not permit us to mention. Finally a rare Great Britain 100 years old. Just send 3d. postage and request our famous approvals. If new illustrated Catalogue and Price List required, add a further 1d.

Lisburn & Townsend Ltd. (MM), 41, Norton St., Liverpool
Stamp Collections purchased for cash.

KING GEORGE VI

A fine packet of unused British Colonials of the present reign from the Leeward Islands, Cyprus, Grenada, Dominica, Mauritius, Kenya and Uganda, also Southern Rhodesia* Jubilee sent free to all applicants for approvals enclosing 24d. postage.

R. D. HARRISON, ROYDON, WARE

FINE FREE GIFT PACKET including set of mint Transjordan, and mint Cayman Isles Pictorial, to all requesting our bargain discount approvals of PICTORIALS, COMMEMORATIVES and TRIANGULARS.

ALLCOCK, 74, Tynyparc Road, Rhiwbina, CARDIFF

Stamp Collecting

How to Make a Good Start

By F. Riley, B.Sc.

SOONER or later every boy turns to stamp collecting as a hobby. More often than not he does this because he sees and envies the collections of his friends, or perhaps he is inspired by the gift of an album or a parcel of stamps. Many of us became collectors when we found partly-filled albums stored away, or were given albums begun years earlier by uncles or other relatives.

We all enjoy arranging our stamps so as to show them to the best advantage, and keeping a keen lookout for other stamps to add to them. To begin with, the young collector can ask his friends for stamps and enlist the aid of all grown-up relatives who work in offices where stamps from overseas are received regularly. These sources of supply, useful as they are, are not sufficient, however, and it is at this stage that the collector turns to the many dealers who are prepared to meet his needs. The usual advice he is given is to buy a large miscellaneous packet, the larger the better. Most dealers prepare packets of this kind containing say 250, 500 or 1,000 stamps, and these are reasonably priced. The cost of such a packet indeed is considerably less than would have to be paid for the stamps in it if they were bought separately, so that this is certainly an economical way of enlarging a general stamp collection.

One word of warning should be given. Do not be surprised to find that a packet containing 1,000 stamps costs more than twice as much as one containing 500 stamps. It should be remembered that the larger packet must contain a greater proportion of somewhat rarer and highly-priced stamps.

Filling in Gaps in the Album

A packet such as this undoubtedly will give the greatest delight to the beginner, who will revel in the task of going through it, examining his stamps carefully one by one, and arranging them. But he will find then that he is only at the beginning of the most interesting part

of his hobby. There will be gaps in his collection, and he cannot fill these by buying more large stamp packets, as the chance of finding the stamps he wants in them will be very small indeed. Then is the time to see what is offered in the pages of magazines that specialise in the hobby, or at least devote part of their space to it. Perhaps the collection so far is weak in one particular

country. Then it will be found that dealers offer what are called long sets of that country, and these provide exactly what is wanted to fill in the gaps. The

latter probably occur chiefly among the more highly priced stamps and for this reason it is well not to worry if such a set contains lower priced stamps already included in the collection. As in the case of the large envelopes, long sets cost much less than they would if the stamps in them were bought singly, so that there is no real loss, and the duplicate can be "swopped," or perhaps even given to a younger brother who has also been seized with the desire to collect.

By this time the collector will have begun to realise the immensity of the task that he has set himself. The number of postage stamps issued throughout the world in the century or so that has gone by since the appearance of the first adhesive stamp, the famous British "Penny Black," amounts to tens of thousands, and it would be a life's work to collect and arrange a display of the stamps of all countries. A good general collection of the more usual stamps can well be got together, and will give its owner the utmost pleasure, but as he proceeds with his hobby he will find that his interest tends to centre on certain countries or certain kinds of subjects, and he will then begin to specialise in these.

Collect Stamps That Interest You

It may be that the young collector will not wait until this stage to pick out special fields in his hobby. He may have had some idea of this in mind at the very beginning, and a very good thing too, for after all it is as well to know exactly where we are going before we set off.

The advice we have already given will be helpful to those who just wish to become general stamp collectors. Those who think over the position first, and decide that from the very beginning they will specialise in certain fields, will make a start in a different way. Their first task will be to decide upon the countries or issues in which they are interested. They may have family associations with a particular country, or they may have seen certain stamps, issued from another, that appeal to them strongly because of their quality or their subjects. They may even have in mind the financial side of stamp collecting. We do not advise readers to think for a moment about this, however, for to give it prominence would lessen the pleasure derived from the jolly pastime of gathering attractively printed slips of paper and arranging them artistically. At the same time, most of us like to feel that whatever we are collecting will at least not lose its value. Many romantic stories have been told of the discovery of stamps that now command fabulous prices, and possibilities of this kind are (Continued on page 33)



The "DIAMOND AIR" Packet



FREE! A Unique Diamond-Shaped Large Air Stamp, also grand Br. Solomon Is. (as reduced illus.), and 10 other fine stamps—Set "Aeroplane over Beira," old "Cape." Map stamp, etc. Just send 3d. postage and ask to see my special "Mercury" Approvals.

Philip J. Dyke (P. T. S.), 35, Buckleigh Ave., London S.W.20

OBSOLETE GEORGE VI MINT

*BERMUDA. Rare 2/- Mottled Blue (S.G.116a) at 8/6.
*MALTA. Old Colours to 3d. (7) at 2/6.
BAHAMAS. 2½d. Blue at 9d. 3d. Violet at 1/6.
*GAMBIA. Obs. 2d. at 9d. 1½d. at 6d.
*HONG-KONG. War Printing inc. 8c. (7) at 10/6.
*NYASALAND. Old Colours to 2d. (4) at 1/3.
*SUDAN. Scarce Palms, 5v. to 5m. at 3/6.
* Blocks pro rata. Prices nett, C.W.O. S.A.E. Please.

THE BIRKDALE STAMP CO.

104, Liverpool Road, Birkdale, Lancs.

COUNTRIES MENACED BY "THE YELLOW PERIL"



8 FREE stamps from Australia, New Zealand and India to all applicants for our World Famous Approvals sending 3d. to cover cost of postage.

Dept. 397, ERRINGTON & MARTIN
South Hackney, London E.9. Est. 1880



NEW YEAR OFFER!

Up to the minute, "Globe-Trotter" offers you FREE, a mint Curacao "Happy Event" Commemorative stamp, and one of the 1943 F. Polish Issue (attack on U-Boat), Rhodesia, 2 1943 Reunion, etc. A grand packet to begin the New Year. Send 3d. now asking for a Globe-Trotter Approval Book and Leaflet to: Globe-Trotter, 70, West Ave., B'ham 20

BARNET & FORD

The Stamp Shop, 5b, High Street, CONWAY, N. Wales
JANUARY 2/6 BARGAIN PARCELS.

G.B., containing Free Gift of 3 Ed. VIII (inverted W/mks), Geo. VI 4d.—1/-, 2/6 Green, P.U.C. comp., G.V. 2/6 and 5/-.

EMPIRE, containing FREE GIFT of 2 N.Z. 1943 Health D's, M. Straits O/P, 5 Geo. VI Malaya, 4 Cyprus, 3 Barbados, 10 Malta (Ed. VII—Geo. VI), Newfoundland, Grenfell m.

Reliant 1944 Catalogue 6/6 post free.

ATLANTIC WAR STAMP FREE

On November 1st, 1943, the FREE POLISH GOVERNMENT IN LONDON issued a new set of pictorial postage stamps for use by the FREE



POLISH FORCES in this country and by POLISH SAILORS at sea. We have been fortunate in obtaining a supply of these historic War Stamps and have pleasure in offering YOU same ABSOLUTELY FREE. The stamp as illustrated depicts an actual incident of a Wellington bomber of a Polish Coastal Command Squadron sinking a German submarine in the

Atlantic. It is inscribed, in Polish of course, Polish Air Force in the Battle of the Atlantic and the stamp is printed in pink colour.

You can get your copy of this most interesting stamp from us ABSOLUTELY FREE by writing to us and asking for our lists and a selection of our stamps "on approval." This Polish issue can only be supplied FREE with an approval selection and if you also send us 3d. in stamps (to cover cost of list and postage of approvals to you). Do not delay; write immediately for this wonderful

FREE OFFER to:

WINDSOR STAMP CO.
(DEPT. M), UCKFIELD, SUSSEX

AUSTRALIA

All Fine Used. Postage Extra.
S.G. SIMPLIFIED Catalogue Numbers.

- 1d. ea. 2, 21, 23, 25, 29, 30, 31, 33, 57, 65, 67, 72, 76, 78.
2d. ea. 1, 3, 10, 22, 27, 28, 47, 49, 53, 54, 58, 61, 70, 75, 76A, 77A, 79, 80, 81, 82, 84, 89, 04.
3d. ea. 37, 41, 78A, 79A, 99, 102.
4d. ea. 32, 39, 44, 45, 93, 100, 101, 103, 09.
6d. ea. 13, 38, 73, 77, 83, 92. 9d. ea. 43, 55, 59, 64, 96.
1/- ea. 12, 46, 50, 52, 97. 1/6 ea. 40, 48, 74, 85, 011.
2/- ea. 42. 2/6 ea. 51, 86, 94, 98. 3/6 ea. 14, 60, 08.
7/6 ea. 010. 30/- ea. 56.

High Values, Overprinted "Specimen," less than quarter Catalogue, SG 15, 5/-, SG 17, 7/6, SG 18, 10/-, SG 87, 3/-.

Any of the above Stamps on Approval against Cash or References.

FRED HARLOW, B.P.A.

133, Bradbourne Vale, Sevenoaks, Kent
*Phone 742 Sevenoaks. Bankers: Barclays Ltd.

TO YOUNG STAMP COLLECTORS

25 different Stamps Free, including St. Vincent, Gambia, Aden, Obsolete Foreign, used and unused. Only to applicants for my famous cheap single and sets of Stamps. Without approvals 9d.

S. H. FLEMING, Newhaven, Glyn Avenue, COLWYN BAY

A FEW ATTRACTIVE BARGAINS

Coronations complete, 202 values, mint 63/-, used 70/-. Coronations and Jubilees, single sets, ask for special price lists, price 1d. each. Gr. Britain Jubilees mint 1/6. Almost all K.G.VI mint in stock, send want list. Sch. Rhodesia Coronations 2 val. 1d. & 2d. mint 8d. New Zealand 1940-Cent, complete, mint 16/-, used 13/6. Liberia 1918, 13 val. used to \$5, Gibbons 36/-, our price 4/6. Liberia Airmail 1936, 6 val. used 1/-, Zanzibar Jub. mint complete 2/6. Ceylon K.G.V Pictorial complete. 11 val. used 7/6. 100 diff. Whole World 1/9. 500 diff. Whole World 12/6 each. Second hand loose leaf Album covers, in excellent condition with leaves as new, prices on application. Postage extra on all orders under £1. Cash with order.

A. LANG LTD. — 213, PICCADILLY — LONDON W.1

For other Stamp Advertisements see pages 30 and viii.

Stamp Gossip

and Notes on New Issues

New Zealand Health Stamps

This month we have two new issues of unusual interest to illustrate and describe. First place must be given to the handsome triangular New Zealand Health Stamps, two in number, which are remarkable for their shape. Triangular stamps are always attractive, if not quite so convenient to handle—and to lick—as the more usual rectangles. The designs add to the interest of the issue, for they show portraits of Princess Elizabeth and Princess Margaret Rose. The portrait of Princess Elizabeth is on the 2d. + 1d. value, which is brown, and that of Princess Margaret Rose on the 1d. + ½d. value, the colour of which is green. Both stamps are illustrated on this page.

The second special issue to which we have to refer comes from the Netherlands Colony Curacao, and has been issued to commemorate the birth this year of a third princess of the Royal Family of Holland. The issue appears in four values, all with the same design: 1½ c., orange; 2½ c., carmine; 6 c., black; and 10 c., blue. As will be seen from our illustration the Royal Family of Holland is portrayed in the design. An issue of the same design has appeared in Surinam, also a Netherlands Colony. The colours of this are the same too, but the values are 2½ c., 7½ c., 15 c. and 40 c., respectively.

By the way, at the time of writing an overprinted set of four values of the current air stamps of Curacao is expected. These stamps are on sale at a premium in aid of a fund for the relief of prisoners of war, and carry the overprinted inscription "Krijgsgevangenen."

The issue is limited to 20,000 sets, and readers who can obtain sets should certainly do so.

The fourth stamp illustrated on this page is one of a series featuring the arms of Algerian cities. The issue appeared in 1942, with seven values showing the arms of Algiers, Constantine and Oran. The arms of Oran were shown on the 2 fr. and 4 fr. 50 values as well as on the green 5 fr. value illustrated here, but the 2 fr. has now been withdrawn.

The Second Free Polish War Issue

The Free Polish Government in London has issued a second wartime set of stamps illustrating events in which Polish soldiers, airmen and sailors have been concerned, together with those who remain in Poland to carry on the war underground. The series contains eight stamps, with values and designs as follows: 5 g., claret, a Wellington bomber attacking a U-boat in the Atlantic, a picture of an actual incident described by the Polish airmen who sank the enemy vessel; 10 g., green, a fine picture of a convoy at sea, with Polish sailors training a Lewis gun on an attacking German bomber; 25 g., violet, a Polish anti-tank gunner in action during the battle of France; 55 g., deep blue, Polish troops

who took part in the Allies' operation in Norway looking down on Narvik Fjord; 75 g., brown, Polish soldiers in the Western Desert, marching towards Tobruk; 80 g., carmine, the late General Sikorski talking to Polish soldiers; 1 7½., dark olive, Polish patriots destroying a railway track, two loosening rails and a third keeping watch, revolver in hand; 1 7½., black, the staff of a Polish underground newspaper at work secretly in an attic, with a revolver handy for use in the event of surprise.

All these stamps are noteworthy for their fine design and their intensely dramatic but truthful character. The range of subjects is very wide, and altogether the set is one that should readily command the attention of collectors.

New stamps that are expected at the time of writing are a Free French set from Reunion, and a Newfoundland issue.

Stamp Collecting — (Cont. from p. 31)

always in our minds, although we know that such things occur very rarely indeed.

Whatever the reason for doing so, there is nothing to be said against starting out with a definite scheme of collecting. For instance, what could be more natural in a reader of the "M.M." than to concentrate on the stamps of British Dominions, or those issued in British Colonies and dependencies. In any of these fields there is ample room for the collector, and there is no doubt whatever that in each of them there is to be found a wealth of stamps that are attractive in themselves and of the greatest interest, while in most cases values are kept up, or even rise steadily. It would not be difficult to make up specialised collections, following out some definite idea, that would always be sources of pride and would represent good investment at the same time.

Whether the collector begins as a specialist, or becomes one after a spell of world stamp collecting, the question remains: "How am I to get the stamps I want?" The answer is from long and short sets of the countries in which he is interested, and then by the direct purchase of stamps required to fill in the gaps that still remain. He may approach dealers directly for the purchase of the individual stamps, but the more usual plan at this stage, and the one that will give him the greatest fun, is to ask for approvals covering his requirements. These are usually sent willingly to readers of magazines in which they are advertised. The dealers trust these readers, who in return should go through approval books or sheets as soon as they can, and return them promptly after taking out the stamps they want.

So far I have said nothing about how to display the stamps. For this an album is essential, and those who start their hobby with an album presented to them are very fortunate in these days, when albums are scarce. They can be obtained, and there are other ways of meeting the difficulties that the war has brought with it, and next month we will deal with the problem and with the best ways of giving collections an attractive appearance.



SOMETHING NEW IN LIFEBOATS

By ARTHUR LAMSLAY

During the war the problem of saving life at sea has presented almost superhuman difficulties. Perilous conditions break at any moment suddenly, in calm and storm, and maybe hundreds of miles from the nearest land, off recognised ship lanes, which means days of exposure and hardship. Therefore there was a real demand for a different type of ship's lifeboat from the one in general use, in which so many valuable lives have been lost through exposure.

Hoping to meet this need, Hugh Mason Crankshaw, B.Sc., M.I.M.E., a prominent Midland industrialist and President of the Birmingham Exchange, and also a keen racing and cruising yachtsman and Vice-Commodore of the Royal Temple Yacht Club in Kent, has designed and patented an entirely different ship's lifeboat. It is completely enclosed, and may be mass-produced easily. It is constructed of $\frac{1}{2}$ in. steel plating, and is all-welded. The general measurements are length overall 40 ft., beam 11 ft., and depth 4.8 ft. The boat will carry the same number of passengers as three of the 26 ft. craft now in use, approximately 90. It is ketch rigged, like the sturdiest and finest of our deep sea fishing fleet, with a total of 340 sq. ft. of sail.

Besides the sails there is auxiliary power from a 20 h.p. Diesel engine which will give the boat about 7½ knots under engine alone. But the engine is for emergency alone, and for generating electric light, working the fans, the powerful searchlight forward, and for heating purposes. The fuel consumption is very low, being 0.36 lb. of fuel oil per b.h.p.

per hour. The fuel oil is carried in tanks in the double-bottoms, and 175 gallons of fresh water is also carried in tanks, which is far in excess of the Board of Trade requirements for the number of passengers the boat will carry.

The all-metal construction makes the boat fire proof, and the metal deck gives obvious advantages over the improvised canvas awning in use to-day, and provides real protection in exposure and stress of weather.

P.R.U.—(Continued from page 3)

machines would go very high, and when they got fairly high the moisture in the air between the lenses in their cameras condensed and fogged the glass. And there were various other queer effects of height and cold which fogged the pictures.

When I was in Rome in 1939, General Valle, who then commanded all the Italian Air Force (the Regia Aeronautica) showed me photographs of the city taken from 20,000 ft., in which one could see all the cars in the streets and, with a magnifying glass, spot the makes of most of them. But 20,000 ft. seemed a long way up, and pictures from that height did not seem so important in July or August, 1939, as they became in 1940 and since then.

Only when war got going did the full need for photographic reconnaissance thrust itself on us, and

only then did the R.A.F. find out how far short of its needs was its equipment. But fortunately the time found the man. And that was when the P.R.U. in their modern state really began as I will tell.

(To be Continued)

Through the Rockies in a C.P.R. Cab—

(Continued from page 8)

from Kamloops at 28 m.p.h., with 15 stops. No. 2864 had behaved and ridden very well, but the 6 ft. 3 in. wheels seemed somewhat too big for such service; they were wasted where speed was moderate and curvature and gradients severe, though the booster had made the many restarts easy enough. Then to bed, rather like Pepys, "not foxed, but plaguey tired, having travelled high upon 15 hours," my head full of pleasant memories and keen anticipation of the big 2-10-4s I should be riding through the Rockies next day. (Sorry! I meant later the same day.)

While comatose in the train I had missed the cairn marking the spot where the last spike was driven on 7th Nov., 1885, by Donald Smith, afterwards Lord Strathcona, marking the completion of the C.P.R. from ocean to ocean. It stands high in the Selkirk west of Revelstoke, at Craigellachie, in a little grass plot by the track. A legend has persisted through the years that the spike was golden, but Matt Crawford, retired locomotive engineer of Kamloops, who was present at the ceremony, emphatically explodes this myth. He is seen standing on the right in the picture on page 8.

(To be Continued)

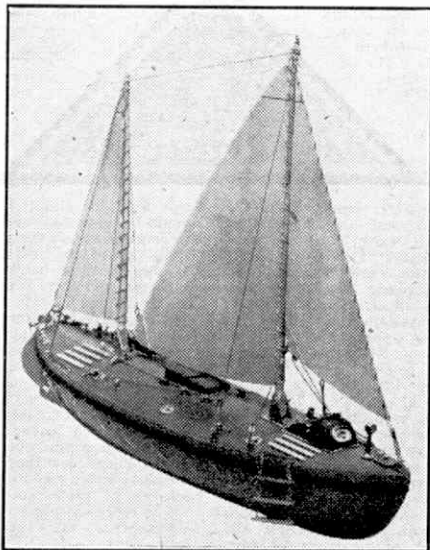

Model of a new enclosed all-metal lifeboat. Photograph by A. Lamsley.

"Stringbags" the Sailor—(Continued from page 15)

our ships in the Atlantic.

Esmonde was awarded the Victoria Cross for the exploit, the only recognition of the part played by the doughty "Swordfish" being a concentrated attack from misinformed folk who once more demanded the "retirement" of "this obsolete death-trap." This was the reward for faithful service, but the "Swordfish" will never be forgotten by its pilots. Whatever new torpedo-planes are produced to carry on the struggle, let us remember with thankful hearts the victor of Oran, Taranto, and the Bismarck action—"Stringbags the Sailor."

RESULTS OF OCTOBER **BSA** MISSING WORD COMPETITION

For the best and most apt sets of answers, of equal merit, the judges have awarded prizes to the following 8 entrants:—

Master Clifford Ashcroft, Orrell, nr. Wigan; Master William Webb, London, N. 15; Master P. Phillip, London, S.E. 23; Miss Christine Harvey, Peterhead; Master C. R. Tuckwell, Hayes, Middx.; Master J. A. Watson, Prescott, Lancs.; each receiving an equal share of the £10 in prizes.

Competitions! Open To All Readers

Which Were the Most Popular Covers in 1943?



Readers thoroughly enjoy our annual Cover Voting Contest, and this month we ask them to tell us which of the 1943 covers they like best. These covers are illustrated above. The reproductions do not give any idea of the brilliancy and colour of the originals, but they will serve as a guide to competitors.

All that is necessary in this contest is that each entrant shall state on a postcard: A, the cover that he likes best; and B, what he thinks will be the order of popularity as decided by the votes of competitors. The covers must be referred to by the names of the

months in which they appeared, and it is not necessary that a competitor's own favourite should be at the head of list B.

The names and addresses of entrants must be written on their postcards which should be addressed to "1943 Cover Voting Contest, Meccano Magazine, Binns Road, Liverpool 13." There will be separate sections for Home and Overseas readers, with prizes in each of 21/-, 10/6 and 5/- respectively for the best entries. Closing dates: Home Section, 29th February; Overseas Section, 31st August.

A New Year Railway "Quiz"

For the railway-minded among our readers we have this month a competition that will not be too great a strain so soon after the trials they have no doubt undergone during the festive season, just at an end. All of them should be able to cope with the series of questions that we are setting them, and even if they cannot give all the answers immediately they will have little difficulty on looking around, or on searching through the "M.M." or their books on railways, in getting the right "dope" on those left over. Then will come the task of preparing their entry, and here we wish to remind them that in the event of ties the judges will base their decisions on the effectiveness of the entries.

Here are the questions in our railway "Quiz."

1. Which railway has locomotives named after famous types of aeroplanes?
2. What is a retarder?
3. What is a fireless locomotive?
4. Why are the axle boxes of some G.W.R. coaching stock painted blue?
5. Which levers in a signal cabin are painted black?
6. What is the code name of a L.N.E.R. covered bogie wagon?
7. Which British locomotive has four wheels under the cab?
8. Which was the first electric railway in Great Britain?
9. What British locomotive visited America in 1927?
10. Which company runs a Turbomotive?

11. What does a board bearing a large letter C indicate when placed at the lineside?
12. What is the wheel arrangement of the "Mogul" type of locomotive?
13. Which railway company built the Lickey Bank?
14. What is a roundhouse?
15. How can vehicles with end doors be distinguished?

For the best list of replies cash prizes of 21/-, 10/6 and 5/- are offered in Home and Overseas Sections. Entries should be addressed "January Railway Quiz, Meccano Magazine, Binns Road, Liverpool 13." Closing dates: Home Section, 29th February; Overseas Section, 31st August.

January Photographic Contest

This month's contest is the 1st of our 1944 series, and in it, as usual, prizes are offered for the best photographs of any kind submitted. There are two conditions: 1, that the photograph must have been taken by the competitor, and 2, that on the back of each print must be stated exactly what the photograph represents.

Entries will be divided into two sections, A for readers aged 16 and over, and B for those under 16, and all entries must be clearly marked with the section letter. They should be addressed "January Photographic Contest, Meccano Magazine, Binns Road, Liverpool 13." There will be separate sections for Overseas readers, and in each section prizes of 15/- and 7/6 will be awarded. Closing dates: Home Section, 31st January; Overseas Section, 31st July, 1944.

Fireside Fun

Sally: "Mother, why has daddy no hair?"

Mother: "People who work with their brains soon go bald, dear."

Sally: "But you have a lot of hair, mummy."

Mother: "Stop asking silly questions, child."

Judge: "Can you explain how you managed to get this wallet out of prosecutor's pocket?"

Prisoner: "Yes, sir, but my fee for lessons is 10/- an hour."

"Eat an apple a day, old man. Keeps the doctor away, you know."

"Better try an onion a day, and keep everybody away."

Teacher: "Smith, tell me the name of an electrical unit?"

Smith, waking up suddenly: "What, sir?"

Teacher: "Right."

Johnny (at school for first time): "How long do I stop here? I'm tired of school."

Teacher: "You needn't grumble. I have to stay here till I'm 65."

Jones: "The doctor told me he would put me on my feet in a fortnight."

Brown: "And did he?"

Jones: "Rather. I had to sell my bike to pay his bill."

Mother: "Tom, your hands are dirty again. You know I always send you out to wash them when you come in to tea like that."

Tom: "Yes, mum, but you see you did forget once."

"Isn't it funny? The pupil of the eye never learns anything."

"No, and the bridge of the nose is never crossed."

"Well, after all the roof of the month is never repaired, you can't play games with the ball of the foot, and the calf of the leg will never moo."

THIS MONTH'S HOWLER

The Centaurs were half hoarse because they lived in damp caves.



Singer, at end of rehearsal for Naval concert: "How many times do I bow?"

Pianist: "You don't bow; you duck."

BRAIN TEASERS

CAN YOU MAKE THIS READ CORRECTLY?

By putting the same vowel in 10 different positions in the following array of 19 letters, an intelligent sentence can be made. THLMNTSXCLLDTHMSLVLS. Can you do this? Here is a further clue—few visitors to this country will believe it.



"Can I go through that gate, boy?"

"Well, Farmer Brown takes his waggons through, so you might."

EASY IF YOU KNOW HOW?

From this let us turn to a Sunday School treat. The curate tried to arrange the children into teams for a game, in turn dividing them into fives, sixes, eights and twelves, but he always had one left over. In the end he gave it up, but a little thought would have solved his problem. Can you solve it, and at the same time say how many children were present. T.K.C.

FIGURE THIS OUT

On subtracting twice a certain number from its square and adding one the result is 81. What number is this? Then try to find two smaller numbers such that the result of dividing one by the other is the same as subtracting the second from the first. T.K.C.

TIME IN BITS

A boy accidentally dropped his watch, and three cracks on the dial were the result. While looking sadly at the wreck he noticed that the Roman numerals on each of the four pieces added up to 20. Where were the cracks?

SOLUTIONS TO LAST MONTH'S PUZZLES

The letter made up with the fragments illustrated in last month's "M.M." is H, and the pieces are put together in the manner shown on this page.

Our second puzzle involved a square divided into 36 smaller squares. Numbering the first row of small squares 1 to 6, the second 7 to 12, and so on, the coins or buttons must be placed on squares numbered 1, 6, 9, 10, 14, 17, 20, 23, 27, 28, 31 and 36.

The names of countries jumbled in our third puzzle are Poland, Turkey, Brazil, Nigeria and Italy.

In our fourth puzzle nobody lost or gained anything. Numbering the matches in our next puzzle 1 to 8 in turn, the sequence of moves is as follows: 4 to 7, 6 to 2, 3 to 1 and 5 to 8.

Whatever is it? The answer is a foot.

BOND'S

We will again be able to supply all the requirements of the Model Maker when the war is over and many new items are now on the drawing board getting ready for the time when we can put them into production together with all our other well known specialities.

We can supply small quantities of materials, screws, rivets, gears and tools, etc., so we will be pleased to know what you are requiring.

No catalogues are available now.

BOND'S O' EUSTON ROAD LTD.

Estd. 1887

'Phone:

EUSton 5441-2

**357, Euston Road
LONDON N.W.1**

LEARN

M·O·R·S·E

Complete
Practice
Unit

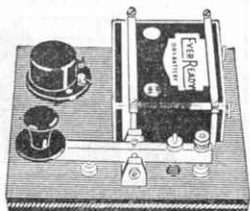

as supplied to H.M. Forces

No. 1261. Complete Key and Buzzer Unit, ready for immediate operation. Heavy commercial key with nickel silver contacts and sensitive triple adjustment. High-tone Buzzer with silver contacts, mounted on bakelite base with cover. Battery Holder, complete with 4.5 Ever Ready battery. All metal parts heavily nickel plated. Polished Mahogany Base, 6½" x 6½". Price **29/6**

Send 1d. stamp for illustrated List

SIGNALLING EQUIPMENT LTD.

Specialists in Morse Equipment

(Dept. 13)

Merit House, Southgate Road, Potters Bar

Boys

Make the most of your holidays. This is just the time for those thrilling cycle runs which do so much to keep you fit.

Be prepared for the blackout with your MILLER DYNAMO SET. It gives PERFECT LIGHTING SERVICE and, taken care of, lasts for years.



Miller Lamps can be bought only through our Dealers, we cannot supply direct.

As supplies are difficult now, consult your dealer as to when he will be able to supply you.

The latest Miller Model No. 526 T.

H. MILLER & CO. LTD., Manufacturers
Aston Brook Street, Birmingham 6

RAILWAYS "Lineside" Plans for "00" Railways give all the necessary detailed instructions for the construction of a very complete range of Architectural and Engineering features. All structures are drawn to conform to B.M.R.S.B. dimensions, with modifications for "Dublo," "Trix" and other established "00" systems clearly shown. Pictorial elevation, elevation, plan, outline and dimensions of every part, are given and listed.

(Below)

SHIPS & PLANES "Planes 1/72. Ships 50 ft. to 1 in. Over 70 Plans released—6d. to 1/-." (Below)

GALLEONS "Planbook," "Building a Galleon," embraces full instructions for building fine models of these grand old ships. It is profusely illustrated and contains in wallet excellent set of eight progress plans for building the "Golden Hind," size 20 in. x 30 in. Price 12/6, by post 13/-." (Below)

YACHT How to build a fast-sailing racing model by new rapid method at cost of only few shillings. Full description, working drawings, scale plans and licence to build model by appt. patent method. Price 3/6, by post 3/8." (Below)

GAS ENGINE Perfect working model which runs on air can be made of simple materials using only ordinary domestic tools. New technique is fully illustrated. "Planbook" costs 2/-, by post 2/2." (Below)

Send 3d. and unstamped addressed envelope. Ask for enlarged January list of over 100 "Lineside" & "Scaleline" Plans, and Modelcraft "Planbooks."

MODEL CRAFT LTD.

77 (M.M.), Grosvenor Road, London S.W.1



MANUFACTURE SUSPENDED UNTIL AFTER THE WAR

STUDY AT HOME FOR MATRICULATION



Wosey Hall (Est. 1894) will coach you by post for London Matric., School Cert., R.A.F. Maths., Engin. Prelim., Lond. B.Sc. Dearee, etc. Tuition continued free if you fail; low fees, instalments. **PROSPECTUS FREE** from Director of Studies, Dept. GK1,

WOLSEY HALL, OXFORD

CRYSTAL SETS

Three excellent types now available.

GAMBRELL W/M type with selector switch, tuning condensers and permanent crystal detector, in closed portable case, 50/-.

VICTORY Pocket type crystal receiver in bakelite box with one earpiece, 35/-.

MARK III type. A two-circuit receiver with tapped inductance, variometer, tuning condenser, perikon and catswhisker detectors, in field case $1\frac{1}{2} \times 10 \times 8"$, with lid and space for headphones. Government model, 85/-.

SUNDRIES. 6-in. Pocket Thermometers, nickel case Vet. Type for animals, 90/100 deg., 1/6. M.H.V. Resistors, glass cased, wire ends, $\frac{1}{2}$ watts, .01, .025, .05, 1/- per set of 3 or 2/6 per doz. **Screened Mike Cable;** flexible sheath, single core, 1/2 per yard. **Multiple Connection Strips** of soldering tags, telephone type moulded mounting, in 25, 50, 75 or 100 watts, at 2/6, 3/-, 3/6 and 4/- each. **G.P.O. Plugs,** 2/- each. **Mentor Battery Indicators,** thermal type signal light, thermal type 2 1/2 in. dial flash panel, 6 volt and 12 volt, 5/-. **Small Solenoids,** "Gemi!" 6 volts 1 1/2 amps., iron plunger, 6/6. **Oldhams Miners' Lamps,** all-metal, for accumulator or dry cell, 7/6. **4-way Cords,** long; suit mikes of handcom phones, 2/-. **Electric Counters** to 10,000 revs., G.P.O., 5/6.

NEW LIST NOW READY. (Limited supply). Regulations require us to charge for this. List sent post free for 6d.

ELECTRADIX RADIOS

214, Queenstown Rd., Battersea, London S.W.8

Telephone: Macaulay 2159

BUILD A MODEL

Corvette Kits 2/3. Submarine Kits 1/9.

Prices include postage.

Agent for Wilson Lorry Kits, Aeroplane Kits.

All dopes, Cements, etc.

1944 list will be ready about March or April.

Three Penny Stamps will bring you a copy.

GEORGE D. CAMPBELL

Dept. MM, 46, High Street, DUMFRIES

35 mm. Films. All description from 6/- Baers, 176, Wardour St., London W.1. Hire Programmes 10/-.

SCALE BUILDINGS:	"00"	"0"
PLATELAYERS' HUTS ..	2/6	5/6 & 6/9
COAL OFFICES ..	3/6 & 4/-	6/6 & 8/6
WEIGHBRIDGE OFFICE ..	5/-	—
SUPER BUNGALOWS ..	18/6	—

Postage 4d. extra

BUILDING LITHOS ..	3d.	3d.
PEA LAMPS, 3.5 v., with Flex, 5d. each, 4/9 dozen		
	Postage extra	

BOOKS:

"A.B.C. G.W.R. LOCOS" ..	1/6, by post 1/8 1/2
"A.B.C. L.M.S. LOCOS" ..	2/-, by post 2/2 1/2
BRITISH RAILWAY ROLLING STOCK	4/6, by post 5/-

WANTED—RAILWAY BOOKS AND MAGAZINES

TYLDESLEY & HOLBROOK

109, Deansgate, Manchester 3

Bla. 7312

CIGARETTE CARDS

This month's selection of interesting sets:

Ardath ... Silver Jubilee ..	3/-
Churchman ... Wonderful Railway Travel ..	5/-
Player ... Army Corps and Divisional Signs ..	10/-
... R.A.F. Badges (with motto) ..	1/6
Wills ... Household Hints ..	1/-

(Postage extra).

Send 3d. for list of 300 different series. Cards purchased—all kinds. From 5/- per 100 paid for cards issued before 1920—perfect condition essential.

R. W. HOUSTON, BCM/EXCHANGE, LONDON W.C.1

WILSON LORRY SCALE MODEL KITS

for boys age 10 and upwards. Built to 4 mm. scale and suitable for all 00 gauge model railways.

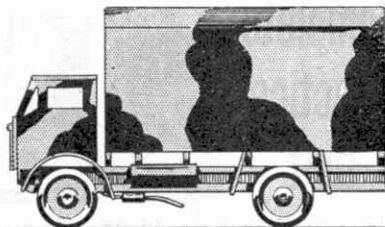

The Commando Battle Wagon in full battle colours as above; complete kit price 4/-, post 3d.

Another good kit is the platform lorry at 2/6 complete, post 3d.

Illustrated price list 4d. and S.A.E.

Agents:

Hamley Bros., Regent Street, London.

Basset-Lowke Ltd. of Northampton.

George D. Campbell, 46, High Street, Dumfries.

WILSON'S LORRIES LIMITED

Dept. M, BRACKNELL, Berks.

Join the Well-Paid Ranks of the TRAINED MEN

MANY THOUSANDS MORE ARE URGENTLY NEEDED. PREPARE YOURSELF FOR A BETTER POSITION AND BETTER PAY

Ambitious men everywhere have succeeded through I.C.S. Home-Study Courses. So also can you. We offer you the benefit of our 52 years' matchless experience as the creative pioneers of postal instruction.



If you need technical training, our advice on any matter concerning your work and your career is yours for the asking—free and without obligation. Let us send you full information regarding the subject in which you are specially interested. DON'T DELAY. Make "ACTION" your watchword.

The successful man DOES to-day what the failure INTENDS doing to-morrow. Write to us TO-DAY.

Special terms for members of H.M. Forces

----- **YOU MAY USE THIS COUPON** -----

(Penny stamp on unsealed envelope)

INTERNATIONAL CORRESPONDENCE SCHOOLS LTD.

Dept. 218, International Buildings, Kingsway, London W.C.2

Please send me the Syllabus of your Courses in.....

Name..... Age.....

Address.....



The I.C.S. offer Courses of Instruction in a wide range of subjects, including:

Accountancy	Insurance
Advertising	Joinery
Aeronautical Engineering	Journalism
Aero Engine Fitting	Machinists Designing
Aero Fitting and Rigging	Machine-Tool Work
Aeroplane Designing	Marine Engineering
Air-Conditioning	Mechanical Drawing
Architecture	Mechanical Engineering
Architectural Drawing	Mine Electrician
Boilermaking	Mine Surveying
Book-keeping	Mining Engineering
Building Construction	Motor Engineering
Building Contracting	Motor Mechanic
Business Training	Moulding
Business Management	Patternmaking
Cabinet Making	Power-House Attendants
Carpentry	Quantity Surveying
Chemical Engineering	Radio Engineering
Civil Engineering	Radio Servicing
Clerk of Works	Refrigeration
Colliery Management	Salesmanship
Commercial Art	Sanitary Engineering
Concrete Engineering	Secretarial Work
Cotton Manufacturing	Sheet-Metal Work
Diesel Engineering	Steam Engineering
Draughtsmanship	Structural Steelwork
Drawing Office Practice	Surveying
Electrical Engineering	Telegraph Engineering
Engineer in Charge	Telephone Engineering
Eng. Shop Practice	Templating
Fire Engineering	Textile Designing
Fitting and Turning	Toolmaking
Foundry Work	Turner
Garage Management	Welding, Gas & Elec.
Gas-Power Engineering	Woodworking
Ground Engineer	Woolen Manufacturing
Heating and Ventilating	Works Engineering
Hydraulic Engineering	Works Management

And most of the Technical, Professional and Matriculation Exams.

STAMP ADVERTISEMENTS

(See also pages 30 and 32)

THOSE GAPS must be filled, ask for Colonial approvals 3d.—6d. and enclose 21d. postage. Purcell, 22, Green Lane, Amersham, Bucks.

STAMPS AT WAR DISCOUNTS

COLONIALS, Coronations and K.G.VI Also EUROPEANS and other FOREIGN Pick any from our celebrated APPROVALS 20/- worth as priced for 5/-, and pro rata OLD AND RARE STAMPS BOUGHT

SAUNDERS & CO., 51, Draycott Avenue. HARROW

MECCANO MAGAZINE

Registered at G.P.O. London, for transmission by Canadian Magazine Post.

EDITORIAL AND ADVERTISING OFFICE:

LIVERPOOL 13, ENGLAND.

Telegrams: "Meccano, Liverpool."

Publication Date. The "M.M." is published on the 1st of each month.

Readers' Sales and Wants. Private advertisements (i.e., not trade) are charged 1d. per word, minimum 1/-. Cash with order. Editorial and Advertising matters should not be dealt with on the same sheet of paper.

Readers' advertisements are published as soon as possible; inclusion in the first issue after receiving them cannot be guaranteed.

Small Advertisements. 1/8 per line (average seven words to the line), or 20/- per inch (average 12 lines to the inch). Cash with order.

Display. Quotations for space bookings, and latest net sale figures, will be sent on request.

READERS' SALES AND WANTS

SALES

Royal Scot Hornby gauge "0" 3a Passenger Set, with large amount of Accessories; excellent condition. Offers—Witham, 60, Airlie Gardens, Glasgow W.2.

Almost 1,000 World Stamps in "Strand" Album; carriage free, 30/-.—Payne, 163, Nansen Road, Leicester.

"Meccano Magazines" perfect condition, January 1924, December 1929, August 1940, October 1943; Six "Boys' Own Paper" 1928; Six copies "The Navy" 1941; Four "Meccano Magazine" Spring Binders. Offers—Morgan, 29, Paignton Road, Wallasey.

Large Hornby Dublo Electric Railway, good condition, £30.—J. Rich, 36, Shrewsbury Drive, Upton, Wirral.

WANTS

Two Hornby L.M.S. Corridor Brake Coaches; One L.M.S. Corridor Composite with Corridor Connections, End Plates and Lamps; One Metro Brake Coach; One Blue Sleeping Car with Corridor Connection and End Plates; and One No. 2 Luggage Van. All in good condition and fairly cheap.—W. E. Buller, 2, Tanfield Road, East Didsbury, Manchester.

"00" Gauge Brass Track, Locos., Rolling Stock and Accessories; any condition; required to start Model Railway for three sons; also "M.M.'s" etc. in good condition. State particulars and price.—Rees, 10, Laurel Road, Prescot, Lancs.

One Corridor Coach and One Corridor Composite Coach; No. 2 Special Hornby gauge "0"; L.N.E.R.; good condition.—Warwick, St. George's Vicarage, Bursley.

Meccano Parts; good condition; state prices.—White, Mavista, Glen Road, Savigbury Green, Hants.

Clockwork gauge "00" Locomotive; Trix Rolling Stock; state condition and price. Also Meccano Nuts and Bolts.—Bridges, Teufyn, Llangoed, Anglesey.

Small Steam Driven Boat required, any type.—H. Bidmead, Walsingham House, Seething Lane, London E.C.3.

"Meccano Magazines," Jan.-Mar. 1943, inclusive; good condition.—Chedgy, 14, Western Road, Mickleover, Derby.

Order your "M.M." Now!

Readers should ask their dealers or newsagents to order a copy regularly for them in order to avoid disappointment. They should write to the Editor if any difficulty arises.

1d. UPWARDS

Every General Collector who can recognise good value should be on our approval service. Not only are our stamps reasonably priced, but also we offer a worth while discount, and other special advantages to regular customers. You need only send a postcard for trial selection. We pay postage.

CAPT. M. CAMPBELL & CO. (Dept. MM)
15, North West House, West Street, Brighton

3 UNUSED

CYPRUS PICTORIALS FREE!

This attractive set will be presented entirely free to serious approval applicants. Only one gift to each applicant. Write to-day.

W. LE MERCIER, 58, LUMSDEN AVENUE SHIRLEY, SOUTHAMPTON

Postal Business Only.

FREE PKT. OF 10 STAMPS (BRITISH COLONIALS) FREE PKT. OF STAMP MOUNTS

To the first hundred applicants requesting approvals the above stamps and mounts will be sent absolutely free together with 2 New Issues. Liberal discount on purchases off approvals. Send at once to secure this valuable gift.

Martin Courtney (Dept. MM), 36, Albert St., Warwick, Eng.

MORE 'IMP' BARGAINS

10 Different	RUSSIA	...	1/6
10 "	RUSSIA	...	2/6
20 "	TURKEY	...	1/6
50 "	BELGIUM	...	1/6
100 "	WIDE WORLD	...	1/6
7 "	GREECE	...	9d.

All above Post Free.

Remember IMP Approvals improve any collection.

STAMP IMPORTERS LTD.

(Dept. M), 12, Jaffray Road, Birmingham 24

To HORNBY FANS and MODEL RAILWAY ENTHUSIASTS

Set of four magnificent Plates of Railway Engines in their correct colouring and details:

- 1.—L.M.S. "ROYAL SCOT"
- 2.—L.N.E.R. "ROYAL LANCER"
- 3.—G.W.R. "KING EDWARD VII"
- 4.—S.R. "LORD NELSON"

Each plate 14 ins. by 9 ins. beautifully printed on stout cartridge paper. Set of 4 complete, post free 21s.

F. WARNE & CO. LTD., 1, Bedford Court, LONDON W.C.2

A Happy New Year to all schoolboys

and may Victory be ours this year. Then we shall all look forward to many new ideas in toys and models. Hamleys will be first with the new lines. With each passing month the departments which war has closed will re-open. Then it will be one of the thrills of your holidays to visit our store. Until these days arrive—and they won't be so very long now—keep on building your own model aircraft or battleship. We have all the best kits and plans. Send a twopenny stamp for the list.

Hamleys
ESTD 1870
HAMLEY BROTHERS LTD

200-202, REGENT STREET, LONDON W.1
(Our only address). Tel. Regent 3161

"R.P." PUBLICATIONS



NEW PUBLICATION: "NAVAL EPISODES"

How often do we read exciting stories of the work being done by our famous warships in this War, of the enterprises in which they are engaged, and of the successes they achieve often against terrific odds. This booklet contains a selection of some interesting episodes in present day naval history, reprinted from our monthly publication "R.P. NEWS"

Price 1/6.

"AIRCRAFT COMPARISONS." Explaining Mark numbers. Part I: Single-engined a.c. Price 9d. Part II: Multi-engined a.c. Price 1/3.

"AIR NAVIGATION." Price 1/6.

"NAVIGATION AT SEA." Price 1/6.

"AIRCRAFT CLASSIFICATION." Price 1/6.

WARPLANES No. 1, "British and Enemy Aircraft." Price 1/6. WARPLANES No. 2, "Interior Details." Price 1/6. WARPLANES No. 3, "The Book of the Spitfire." Price 1/3. WARPLANES No. 4, "British and American Aeroplanes." Price 1/6. WARPLANES No. 5, "The Book of the Wellington." Price 1/3. WARPLANES No. 6, "Allied and Enemy Aircraft." Price 1/6. WARPLANES No. 7, "More Interior Details." Price 1/6.

REAL PHOTOGRAPHS CO. LTD., SOUTHPORT

Two opportunities for Amateur Photographers

Your photography will become much more interesting if you do it all yourself. To help you, we will send, for 3d. in stamps, these three publications. A 32-page booklet called 'Home Photography' which tells you how to develop your own negatives, how to make Gaslight and Bromide prints, how to do Flashlight Photography and how to make Enlargements. A folder about Azol, the concentrated one-solution developer, with full Time and Temperature tables for tank or dish development. There is also a fully illustrated list of Chemicals, useful sundries and accessories to help you in the work.



THESE THREE PUBLICATIONS
WILL BE SENT TO YOU FOR
3d. IN STAMPS

Special Trial Offer:

For 2/3 P.O. Johnsons will send you post free (G.B. only) a trial set of Chemicals, including 1-oz. bottle of AZOL, to develop eight spools 2 1/2 in. by 3 1/2 in., 4-oz. tin ACID-FIXING, making 30-60 ozs. solution, one packet AMIDOL DEVELOPER, enough for 2 to 3 doz. bromide or contact gaslight prints.

Be sure and mark your letter Dept. E/M
JOHNSON & SONS Manufacturing Chemists LTD., HENDON, N.W.4

THE MECCANO MAGAZINE

MECCANO

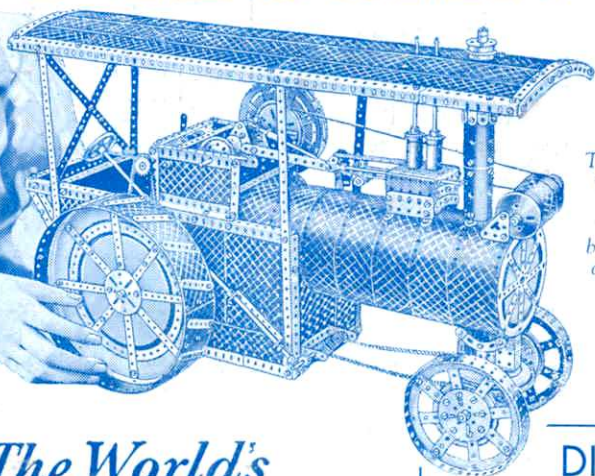

This splendid model of a Traction Engine is built entirely of standard Meccano parts.

The World's Greatest Toys

We are sorry that we cannot supply these famous toys to-day, but they will be ready for you again after the war. Look out for the good times coming!

HORNBY TRAINS

A Hornby Pullman Train passing under a Gantry Signal.

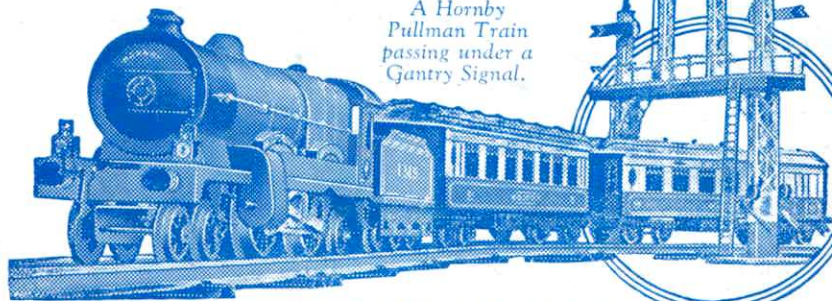

MECCANO LIMITED, BINNS ROAD, LIVERPOOL 13

DINKY TOYS



De Havilland "Flamingo."
Used by R.A.F. for transport and communication work.



Buick "Viceroy" Saloon Car.