

meccano.co.uk
VOL. XXIX. No. 3

MARCH 1944

MECCANO

MAGAZINE



GIANT CREEPER CRANES

6^D

ELITE GLIDER No. 2

36 inch span

COMPLETE KIT 9/1, Post Free

Contents of Kit: CUT-OUT RIBS,
DOPE, CEMENT, TISSUE STRIP, ETC.,
and FULL-SIZE PLAN.

A diamond fuselage machine with high parasol wing mounting, cleverly faired into the wing, giving SUPER STABILITY and that long floating glide which seeks and holds thermals. For its size, this model is unbeatable. Average duration is of 45-50 seconds, without thermals, off 100 foot tow line.

SOLIDS

SPITFIRES, HURRICANES, Etc., Etc.
from 5/4 Post Free

SEND 3d. for NEW CATALOGUE
illustrating a FULL RANGE of KITS

ELITE MODEL AIRPLANE SUPPLIES
14, Bury New Road, MANCHESTER 8

During the National Emergency only limited
supplies of

VITALITY BULBS

are now likely to be available.

If your Dealers cannot supply you with the type you require, do let us have full particulars, together with their name and address, because it might just happen that we know of factors who may be able to supply them.

VITALITY BULBS LTD

NEVILLE HOUSE,
NEVILLE PLACE,

WOOD GREEN
LONDON, N.22

BECK'S CHEMISTRY

Experiments at Home for Black-out Evenings

SPECIAL OFFER!

PARCEL OF USEFUL APPARATUS
with Booklet: "Experiments in Chemistry"

Post **10/6** Paid

England, Scotland and Wales Only.

Send stamped (1d.) addressed envelope for Price List of other equipment.

BECK (Scientific Dept. G), 60, High Street
STOKE NEWINGTON, LONDON N.16

Here are more
U.S.A. RANKS!



1. Officer's U.S.
2. 2nd Lieutenant.
3. 1st Lieutenant.
4. Captain. 5. Major.
6. Lieut.-Col. 7. Colonel.
8. General (one, two and three stars for Brig.-Gen., Maj.-Gen., and Lieut.-Gen.)

HOW TO
RECOGNISE
OFFICERS
INSIGNIA

... and this is how you
can recognise Britain's
largest retailers of Cycles
and Cycle Accessories

Look for
the name
HALFORDS

220 Branches in England,
Scotland and Wales. For the
best advice and service.
HALFORD CYCLE CO. LTD.
Head Office:
BIRMINGHAM

There's a HALFORDS
in YOUR district



THE MECCANO MAGAZINE



FROG

SCALE
MODEL
AIRCRAFT



MADE IN ENGLAND BY
INTERNATIONAL MODEL AIRCRAFT LTD

For the sole Concessionaires

LINES BROTHERS LTD · TRI-ANG WORKS · MORDEN ROAD · MERTON · LONDON · S.W. 19 · ENG

When this aim



turns to this



Webley

will be waiting

to supply sportsmen
the world over with
their celebrated
**WEBLEY AIR
RIFLES AND
PISTOLS**

Webley & Scott Ltd.
Birmingham
England
(Est. 150 years ago)



MASTERPIECES IN MINIATURE!

Long experience and consummate skill in the art of model-making have made the name Bassett-Lowke famous for detail-perfect scale models of all kinds. To-day we are fully engaged on work for H.M. Government, but as soon as victory is won we shall be ready to resume production of Model Railways, Ships and Engines for all our customers.

Our London and Manchester branches are still open and our wartime staff will be pleased to give assistance on any model matters.

"Building a 2½ in. gauge Flying Scotsman," fully illustrated with drawings and photographs, price 1/- post free.

Wartime stock list (L/17), price 4d. post free.



BASSETT-LOWKE LTD
NORTHAMPTON

LONDON: 112, High Holborn, W.C.1
MANCHESTER: 28, Corporation Street



Reconnaissance Flight

R.A.F. photographer making one of photography's many contributions to the War effort. Miles of film are needed for super cameras like his. Photography is mobilized for war, so don't blame your dealer if he says "Sold out of Selo!" Claims of the Services come first. After victory, Selo films will be plentiful again, faster and better than ever. Till then our chief task must be **SERVICING THE WAR.**

ILFORD makers of **SELO** films
LONDON

TRI-ANG

ALL BRITISH TOYS

LOOK OUT FOR THESE TRADE MARKS



TRADE MARK

International
Model Aircraft Ltd.

**FROG
MODEL
AIRCRAFT**



Lines Bros. Ltd.
TRI-ANG TOYS



Pedigree Soft Toys Ltd.
DOLLS

*Pedigree
Pets*

Pedigree Soft Toys Ltd.
**Hygienic
SOFT TOYS**



Unique & Unity
Cycle Co. Ltd.

**JUVENILE CYCLES
TRICYCLES
FAIRYCYCLES**

LINES BROS. LTD.

AND SUBSIDIARY COMPANIES
Unique & Unity Cycle Co. Ltd., Pedigree Soft Toys Ltd.
International Model Aircraft Ltd.

TRI-ANG WORKS, MORDEN ROAD, LONDON S.W.19

BSA Bicycle carries ten times own weight

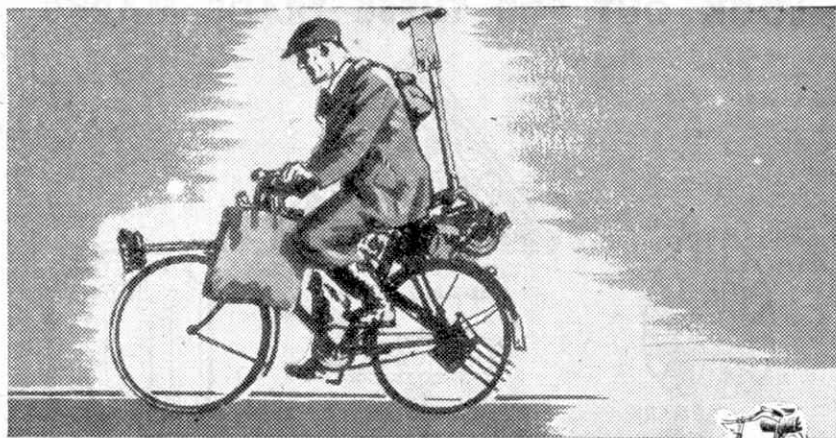

A really strong man may lift twice his own weight but that's about all, and as for carrying it miles and miles that would be impossible.

Yet here's the true story of a B.S.A. Bicycle that cheerfully carries 10 times its own weight — about 300 lbs. The owner loads it with a spade, fork, broom, tools, food, and a heavy lawn mower. Finally he mounts his B.S.A. himself and off he goes to work, thanking his stars his B.S.A. is so enormously strong.

Naturally we don't advise you to follow his example, but it just shows you what these famous machines can do. No wonder everyone wants a B.S.A. Bicycle. But they are scarce nowadays. Just the same, get your parents to put your name on the dealer's waiting list and you will soon have a B.S.A. of your own to boast about.



BSA THE BICYCLE YOU CAN'T BEAT

B.S.A. Cycles Ltd., Birmingham, 11.

Next Month: "THE NAVY AND INVASION." By Capt. B. Acworth, D.S.O.

MECCANO

MAGAZINE

Editorial Office:
Binns Road
Liverpool 13
England

Vol. XXIX
No. 3
March 1944

With the Editor

Meccano on War Service

Many readers have asked from time to time whether Meccano has been used in any way in the great war effort. It certainly has, and if I were free to do so I could tell a wonderful story about this. Until after the war, however, I can only give a very brief outline of the part that Meccano has played.

In Service training schools Meccano mechanisms have been in great demand for demonstration purposes. Working models of gear-boxes of all kinds, differentials, and epicyclic gears have been found very helpful in giving trainees a clear idea of the principles on which Army vehicles and other equipment depend for their operation. Meccano has been used also to build up the actual operating mechanism of an elaborate indicator device used in connection with anti-aircraft defence at an important gun control centre.

Commanding Officers of coastal defence batteries have made use of Meccano mechanisms in various ways. For example, at one station moving targets for automatic miniature searchlights required for training purposes were developed entirely in Meccano. The necessary experimental work in devising these mechanisms would have taken a long time and would have been a costly job if it had been carried out with specially produced engineering parts. The use of Meccano parts made the cost negligible, and within 24 hours of receiving the request for the apparatus our model-building experts had designed and produced a satisfactory mechanism built entirely from standard Meccano parts. Another interesting and useful purpose was served by Meccano parts when a Naval signalling training centre required a number of miniature semaphore signalling mechanisms. These were quickly

constructed in Meccano and have given complete satisfaction to their users.

Meccano parts have played a big part also in the construction of real machines used for producing war equipment in emergency.

After the war I hope to tell the whole story of "*Meccano on War Service*," and I assure readers it will be very interesting.

The Great Invasion

No topic is of such interest just now as the "Great Invasion"—the attack by the Allied Nations on Hitler's so-called "Fortress of Europe." This month Mr. C. G. Grey deals (pages 74-6) in graphic style with the part that air power will play in the coming onslaught and with the men who will be in control. Next month Captain Bernard Acworth, D.S.O., R.N. (ret'd.), will write about the Naval side of the attack.

This Month's Special Articles

	Page
Air Power in the Great Invasion by C. G. Grey	74
This Atom-Splitting Business	.. 77
Remarkable Runs of Years Ago —I, by R. A. H. Weight	.. 78
Creeder Cranes for Bridge Building	80
Through the Rockies in a C.P.R. Cab—III, by Edward H. Livesay	.. 86
Wild Life in Man's Service by Harold J. Shepstone	.. 88

Air News, 82. Engineering News, 85. Railway News, 90. General Interest, 84. Photography, 92. From Our Readers, 93. Club and Branch News, 98. Meccano Suggestions, 94. New Models, 96. Model-Building Contest, 97. H.R.C. Pages, 99-101. Stamps, 103, 105. Competitions, 107. Fireside Fun, 108.

Air Power in the Great Invasion

By C. G. Grey

(Founder of "The Aeroplane," 1911, Editor until September, 1939)

BY the time these notes appear the combined might of the Allied Nations may have started the Great Invasion of what the Germans call "Fortress Europe"—that is all the countries which they have occupied, though most of them will be pretty poor fortresses when things get going. And the combined might of the United Nations by land, sea and air is something terrific, as the Germans will find.

Therefore this seems a good time at which to give our readers a simple explanation of the mechanism of such an invasion, for if all the staff work has been properly done the whole thing will fit together as neatly and as interdependently as do the parts of a Meccano model. And if any part is missing there will be a consequent delay or breakdown in the progress of the invasion.

First bear in mind that excellent definition of modern war produced before this war by Lieut. Col. L. V. S. Blacker, famous as the originator of the "First Over Everest" flight. He was an officer of the Guides, the famous N.W. Frontier regiment, and he flew in the Royal Flying Corps in the last war. He says: "The Air Force is the striking force, the Army is the holding force, and the Navy is the transport Service." The Navy and the Army now recognise that neither of them can operate against an enemy who has an air force unless they have air cover. And, to be effective, that air cover must definitely hold the command of the air against the enemy's Air Force.

Given the command of the air, which will stop the enemy's aircraft from attacking either our shipping or our road transport, or from doing serious damage to our troops in trenches or strong-points, then the job of our Air Forces is to attack the enemy's troops and their defence positions on the ground, so that our Armies can walk in with the least possible opposition and consequent damage. In other words, our Air Force has to blast a way through the enemy's defences along which our troops can advance.

The arrangement of the Air Forces for these jobs is quite simple in general idea, but terrifically complicated in detail. The combined Air Forces of the United Nations—U.S.A., British (including Dominions), Polish, Dutch, Belgian, Norwegian, and some French—are divided, for purposes of the invasion, into the Tactical Air Forces and the Strategic Air Forces.

The U.S.A.A.F. is still part of the U.S. Army, so would naturally come under the combined Army Command. The Tactical Air Force R.A.F., which includes detachments of "free" or "émigré" Continental air forces, would normally co-operate with the Armies, for it was known as the Army Co-operation Command R.A.F. until the Desert

Campaign in North Africa showed that something more than mere co-operation was needed, and that the section of the R.A.F. which was working for the Army must be welded to it, though not absorbed into it. The combination is rather that of a telescopic sight with a rifle. It is essential to the operation of the weapon, and yet is not a part of it.

Now remember the classic definition of Strategy and Tactics. Strategy is concerned with the area of war; tactics are concerned with the field of battle. That will give you a general understanding of the difference, although it is not a hard and fast rule,

because, as a senior officer of the R.A.F. said to me lately, you cannot draw a dotted line in the air between field-of-battle tactics and war area strategy. "Nor," he added, "between strategic and political bombing."

By which, I take it, he meant that the Chiefs of Staffs might want to bomb a munitions centre or a submarine base for strategic reasons, but their bosses, the Politicians, might order them to bomb some non-productive capital city, just to shake the moral state of the enemy or of some wobbly neutral.

The Supreme Allied Commander is General Dwight Eisenhower; commonly called "Ike," by friends and subordinates alike. He proved himself in North Africa to be a great commander and leader of men; and, above all, he proved that he could get our officers and men, of all three Services, to work as gladly and as enthusiastically for him as for their own officers. And there was much joy among our people when he was appointed, after the threat of appointment of a U.S.A. General who had seen nothing of modern war.

The Deputy Commander, Supreme Allied Command, is Air Chief Marshal Sir Arthur Tedder, who has been accidentally the great discoverer of our way. He flew to Cairo to be 2nd in Command R.A.F., Middle East, to Air Chief Marshal Sir Arthur Longmore, after Air Marshal Boyd, on his way out to the same job, had been shot down over Sicily and captured. Soon after that Sir Arthur Longmore came home, and Tedder remained as Air Officer C-in-C. Before long people were saying that he ought to be C-in-C. of all forces in the Mediterranean—Sea, Land and Air. According to his "Middle Easterns" there was not a station or a unit of the R.A.F. in the Command, from Tripoli on the verge of Tunisia to Baghdad in Iraq, that he had not visited. And the number of officers and men whom he knew by name was astounding. He left his Chief of Staff Peter Drummond (since knighted) to run the office while he ran his men and their operations. And he always piloted his own aircraft, which clinched



General Dwight D. Eisenhower, Supreme Commander of the Second Front.

the admiration of the R.A.F. for him.

Now Sir Arthur Tedder has a still bigger job, as Deputy Commander of all the Allied Forces for the Great Invasion. Evidently as an airman he will pay special attention to air strategy and tactics, but in the Middle East he worked so well with General Alexander and General Montgomery that he can handle the Army side as well. Besides which he was himself an infantry officer a year before the last war and in it until 1915.

Under the two big chiefs come the Navy Commanders, who have to operate the troop-transports and supplies by water and protect them against sea attack. They will also use their guns against enemy positions ashore to cover landings or to smash shore fortifications. And they will be responsible for mine-sweeping. Thus the Navy will be a sea-transport auxiliary to the Army and Air Force.

Under the Supreme Command also will come the Armies of Invasion, from the West. As at present understood, the Armies of Invasion from the Mediterranean or through the Balkans, which may draw much of their supplies from India, and their oil from Iraq and Persia, will come under the Mediterranean and Middle East Commands. They will have their own Naval transport and Tactical and Strategic Air Forces.

The British Armies in Western Europe are to be commanded by Sir Bernard Montgomery. A U.S.A. General will command the U.S. Armies. And both will come under General Eisenhower and Air Chief Marshal Tedder. Here I would remark that Eisenhower, or Eisenhauer, to give it the proper German spelling, means an iron-hewer—a man who cuts iron. A hay-tedder is an agricultural implement which

picks up the cut hay, whirls it round, and lays it out in swathes. But "to ted," in some countries, means to give a sharp edge to a tool, such as a scythe or sickle. So the combination of a tedder and an iron-cutter looks promising!

The Air Officer Commanding-in-Chief all the Tactical Air Forces working with the Armies of Invasion is Air Chief Marshal Sir Trafford Leigh-Mallory, who, during the Battle of Britain, commanded No. 12 Group, which covered the East Coast from the Thames to Scotland. After that he took over Fighter Command, which later absorbed Army Co-operation Command, and turned it into the Tactical Air Force. And to-day Sir Trafford commands the combined Tactical Air Forces of the R.A.F. and of the U.S. Army Air Force. The Tactical Air Force, R.A.F., is commanded by Air Marshal Sir Arthur Coningham, who, as will be seen hereafter, developed the tactics of ground attack with the Desert Force in Africa. Fighter Command R.A.F. still has a separate existence under



A group of the Supreme Command. Seated (left to right) are Air Chief Marshal Sir Arthur Tedder; General Eisenhower, and General Sir Bernard Montgomery. Standing (left to right) are General O. Bradley, Admiral Sir Bertram Ramsay, Air Chief Marshal Sir Trafford Leigh-Mallory, and Lieut.-Gen. Bedell Smith.

Air Marshal Sir Roderic Hill, though it comes under the C.-in-C. Tactical Air Force. Which means, as I understand it, that as Fighter Command it does what the original Air Defence of Great Britain Command did, and controls the Anti-Aircraft Guns, and Searchlights, and the Royal Observer Corps, and that includes running the night fighter squadrons and the fighter squadrons which chase day raiders.

When the Great Invasion starts the Luftwaffe will make desperate efforts to bomb our ports of embarkation by day and night, and to attack railways and junctions and marshalling yards through which troop-trains must pass. Obviously the protection of such targets will be the job of Air Defence G.B.

Equally obviously another of the Command's jobs will be the protection of shipping while crossing the Channel or the North Sea, and the Tactical Air Force will doubtless help also.

Coastal Command also will have a hand in this work, primarily watching for submarines or loose mines. But Air Defence G.B. will have to provide the "air umbrella."

In fact the work of the Tactical Air Force will only start properly when the Armies begin to reach the other side. Their work will be to "prepare" the landing beaches, much as the gunners' artillery preparation clears the way as much as it can for an infantry attack.

That work has, in fact, already begun. The light bombers, such as "Mitchells," "Marauders," "Bostons," "Beaufighters," and so forth, and the fighter-bombers such as the older types of "Spitfires," and the "Typhoons" and "Whirlwinds" and "Mustangs" have been hammering away at the gun-positions and fixed defences of what the Germans call the Atlantic Wall, or the



Air Chief Marshal Sir Trafford Leigh-Mallory, Allied Air Commander-in-Chief under Gen. Eisenhower.

West Wall. By smashing those defences now, and keeping them smashed, the Tactical Air Force is giving plenty of practice to the new pilots and crews who are pouring over from the British Dominions Air Training Plan in Canada. And the U.S.A.A.F. Tactical Force men are getting their baptism of fire in the same way.

Moreover, the more the West Wall is smashed now the less smashing there will be to do when the invasion starts, and the more the combined Tactical Air Forces will be free to go ahead and blast a way inland for the advancing Armies.

That is where the Tactical Air Force will properly come into its own. The technique and the tactics of ground attack were developed by the Desert Air Force with Montgomery's 8th Army in Africa. Under Air Vice-Marshal Arthur Coningham, now Air Marshal Sir Arthur, but always known as Mary (which should be Maori, because he is a New Zealander), the R.A.F. blasted the way for the Army from Egypt to Benghazi, covered its retreat to Egypt, and blasted its way forward again from El Alamein to Tunis. To-day Mary Coningham is an Air Marshal Commanding No. 2 Tactical Air Force, based in Great Britain.

An interesting point is that the ground tactics of the R.A.F. did not work in that part of Italy above Naples on the Mediterranean and above Foggia on the Adriatic, because the mountain passes and defiles made close support by aircraft impossible. All that the R.A.F. could do was to keep the air clear of enemy bombers attacking our supply lines, to bomb the German supply lines farther north, and to bomb villages

on the mountain-sides which were held by the Germans. But their ground-attack methods could not work against guns stowed in caves on one side of a defile to shell roads on the opposite side.

In western Europe there are no such mountains and defiles to turn into defensive fortresses, so the Tactical Air Forces will have almost open country on which to work, until they come to the hills along the Rhine and the Black Forest. There is practically not a hill between Hamburg or Holland and Berlin. There is broken country in the Ardennes (East Belgium) and Luxembourg, but the Germans brought their tanks through when they defeated the French, so we can go through the other way.

An interesting point to remember is that, as the Tactical Air Forces advance, so their bases will go forward with them. When the Invasion Armies have driven the Germans back, say, 50 miles or so, then we can set up repair depots and aircraft bases on the coast, which we can supply by sea. The fighters and medium bombers will work from advanced aerodromes 25 miles from the front line, or even less if, as in Italy, we have such command of the air that the Luftwaffe dare not to come over our side of the line—as happened in France after August, 1918. And these advanced airfields will draw supplies from the depots behind.

And so the units of the Tactical Air Forces, whether Wings or Groups, will leap-frog forward, till at last the pilots and themselves flying over what had been German Army Grand Headquarters, with white sheets spread all over them in sign of surrender, as at Pantellaria.

In the meantime the Strategic Air Forces will have been doing their work. That is the hammering of cities, towns, and even villages, where armament is made, or of political centres the destruction of which, in the opinion of our politicians, would create a psychological momentum in favour of surrender. Strategic bombing of armament areas is often called "long view" bombing, because one has to look a long way ahead to see how it will affect the war.

If the Tactical Air Force smashes a lot of aircraft on enemy air elds the effect is immediate. Those enemy squadrons cannot take the air until they get new machines from their depots. Then the depots have to get replacements from the factories, and if our strategic bombers have smashed the factories there are no replacements. But the factories may have machines in store somewhere else to send to the depots.

Then, when the workshops have got going again, they may find that we have smashed the ball-bearing factory or the steel-works or the radio factory, from

which they draw essential parts or raw material, and so the output of machines is stopped. And that is looking a long way back from the front line aerodromes. So you see why Strategic Bombing has to be directed by looking a long way ahead.

The enemy people will never be subdued by bombing, because they can always, in extremities, get out into the open country, as our evacuees have done—and remember there is a lot more country in Germany into which to evacuate than there is here. What our Strategic Bombing has done and is doing and can do, is to smash production and communications,

and so stop supplies of armament to the fighting men and of the needs of life to the workpeople.

In the Great Invasion long-view bombing of munition areas and sources of raw material will matter less than the smashing of communications. Breaking up a great railway and road junction, especially the rail and road bridges along which the enemy has to bring his munitions to his front line, will weaken his defence-troops within a day or two; whereas, smashing the factories where those munitions are made might not affect the fighting-power of the front-line troops or front-line air squadrons for weeks or months. Probably the German troops in North Russia were so badly beaten in January because of the way in which the R.A.F. smashed the great gun works and tank-works and steel-works in the Ruhr a year earlier, and because of the cutting-off of power by the bombing of the Mohne and Eder dams in the Spring of 1943.

The damage done during 1943 has been many times as great as in 1940, 41, and 42. The R.A.F. Bomber Force has been multiplied many times over, and all the big attacks on Germany are now made by modern four-engined "Halifaxes" and "Lancasters" or high-speed "Mosquitoes." A few of the older and slower "Stirlings" are used. "Wellingtons," "Hampdens," "Whitleys" and other two-engined types have now been handed over for mine-laying and anti-submarine patrols, and for bombing in Italy, where enemy fighters and flak are scarce.

Besides that we must remember that on 27th January, 1943—an anniversary (Continued on p. 106)



Air Chief Marshal Sir Arthur Tedder; Marshal of the R.A.F. Sir Charles Portal, and Air Marshal Sir Arthur Coningham.

Have You Ever Thought About This?

What is this Atom-Splitting Business?

FROM time to time we are startled by news about atom splitting, which seems to threaten to provide us with sources of power that will make our great steam engines and electric power stations ridiculous, both in size and in output. We are told that splitting up the atoms in an ounce or two of matter would give sufficient energy to take a giant liner across the Atlantic Ocean and back again; and we have even been alarmed by suggestions that similar processes in certain materials would give us bombs that would not merely explode, but would start everything else around them exploding in a tremendous uproar that would make the latest bombing of Berlin seem like the setting off of a harmless squib. What is there in all this?

Now atom-splitting is not entirely new. As a matter of fact atoms have been splitting themselves for ages, on Earth, and in the Sun and other hot stars, but we knew next to nothing about this until recently, and then we did not know how easy it was to split atoms ourselves. In fact, if anybody had suggested splitting atoms at all, we should have remembered that a mere cubic inch of air has getting on for 1,000 million million million atoms in it, and we should have laughed at the idea of cutting up anything so incredibly tiny. Yet to-day we all split atoms and make the pieces from them work for us. We do it every time we switch on a radio set!

CATCHING THE ELECTRONS

The revelation that atoms split themselves came nearly 50 years ago. At that time everybody was still astounded by the discovery that there were rays, those we now call X-rays, that were invisible and could pass through black paper and pieces of metal and wood almost as if these were not there. It was found that similar rays were given out by compounds of uranium, a metal that had been known for over a century and had not been considered particularly useful or remarkable, apart from the fact that its compounds had a trick of glowing slightly in the dark. Then came the amazing revelation that it was slowly breaking up, continually shooting out little bits of itself as well as giving off a kind of X-ray. One of the chips was soon identified with a mysterious "ray" that comes out of vacuum tubes through which a high-voltage electric discharge is passed—a ray that has turned out to be a stream of extraordinarily tiny particles with practically no weight, but with a negative electric charge. We all know those particles to-day. We call them electrons, and these bits of atoms nowadays do a lot of good work for us.

There are five of these amazingly small constituents of atoms. Besides the electron there is the positron, which is similar except that it has a positive charge. Then there is the proton, which also has a positive charge, but is much weightier than the positron. The two remaining chips are the neutron, which has no charge at all and is of about the same weight as the proton; and a kind of building unit, made up of two protons and two neutrons, to which the name of alpha particle is given.

There may be others, but these are enough to be going on with. Some of them are shot out of their atoms by uranium and other radioactive materials, the best known of which is radium; others can be knocked out of atoms by heating them or letting light fall on them, actions that set free electrons from certain substances, or by bombarding them. The "shells" used in these small scale artillery exercises are protons and alpha particles, and the guns from which they are fired are strange electric devices. In one of them, called the cyclotron, the tiny shells are whirled round and round electrically, like stones

in slings, until they work up a tremendous velocity, and are then shot off into the atoms to be split up. In other forms of electric gun the projectile is speeded up by means of very high voltage.

POOR SHOOTING?

The marksmanship is very poor, for the scientific gunners cannot pin-point particular atoms, but simply shoot into the mass in the hope of scoring a hit. In one set of experiments of this kind, in which alpha particles were shot into nitrogen, only one out of every 45,000 "shells" actually struck its target!

The reason for this is interesting and indeed somewhat startling. The atom, which we once thought of as a sort of round solid affair, turns out to be mostly space. The bricks of which it is made are so very small that the actual material present is no larger in proportion to the space occupied than a cathedral is to the Earth, so it is not surprising to find that even the small particles that hit atoms nearly all pass right through them. The nucleus, a tiny central mass containing protons, is the real target, and on the rare occasions when it is hit strange things happen. For instance, one element may be changed into another, so that the dream of the ancient alchemists is at last fulfilled. Unfortunately for those who would like to make gold out of lead, or make some other profitable transformation, the scale on which the changes take place is far too small to be of any practical value. The bits and pieces knocked out too cannot be handled, and indeed are not seen, as they are so tiny. They reveal themselves by making vapour trails in glass box, of much the same kind as aeroplanes flying too high to be seen sometimes make, or by striking minute sparks on plates coated with special chemicals.

There is another difficulty in making use of atom-splitting for practical purposes. This is that it costs too much. It is true that in many instances splitting an atom releases energy, but far more energy has to be put into the process than can be got out of it. Our ways of releasing the energy bound up within the atom are worse than using a tank and the members of its crew to crack a nut by driving over it. Besides this, too much ammunition has to be wasted, as we have already seen, so that for the present at any rate the idea of splitting the atom as a source of power is just moonshine.

BLOWING UP THE EARTH

Yet something may come of all this. A few years ago the world was startled by the announcement that one of these changes could not be stopped once it had started. It was said that those who made the discovery became really alarmed and stopped their experiments before they got out of hand. A substance was discovered to break up, when bombarded by neutrons, in such a way that neutrons moving with greater speed than those shot into it were set free from it. These shot into other atoms of the substance roundabout, breaking them up and producing a still larger number of the faster neutrons, which in turn took up the good work, so that the explosion spread outward and became more and more intense. Apparently no power on Earth could stop it. It was like setting fire to the centre of a magazine of explosives.

This was certainly startling, and there have been rumours that German scientists were developing this atomic bomb for use as a secret weapon, the effect of which would be overwhelming. Nothing has been heard of it in this guise, however, and it seems likely that little will come of it, for the material that breaks up in this remarkable way is more than scarce; the quantity of it in the world is infinitesimal.

Remarkable Runs of Years Ago

I—Red Letter Days from my Note Book

By R. A. H. Weight

AS I ponder over three decades of railway travel experiences, memories come crowding in of interesting runs totalling hundreds of thousands of miles in Great Britain, on the mainland of Europe and in North Africa. In peace and war, as soldier and civilian, on duty, business or pleasure, my journeys have covered a dozen countries from Eire to Palestine. They have been made under almost every conceivable condition of speed and comfort, or the lack of both, from the fastest and most luxurious Pullman, sleeping and restaurant car expresses, to crawling overseas troop trains composed of four-wheeled wagons.

By far the largest proportion of my mainline and long-distance travels were on English lines, and among these were certain memorable trips, by ordinarily advertised fast trains, which remain veritable "red-letter days" in my recollection.

The first of these took place about 10-12 years ago on the Great Northern section of the L.N.E.R., with which I was closely in touch for more than a quarter of a century. At the end of 1931, when schedules had been more or less stagnant for some time, acceleration was under consideration, and it was decided to make a number of test runs to see what margins existed under varying conditions of load and locomotive power. On the G.N. section the first trial sprints took place from Peterborough to King's Cross, 76½ miles, over a moderately difficult road, with a train weighing about 235 tons full, consisting of the Cromer and Grimsby portions of the north express then due in London at 4.30 p.m., and given the liberal allowance of 92 min. in the public timetable. The test train ran up as a first part, being provisionally allowed 73 min. with a start from Peterborough at 2.51 p.m., but the special working circulars for those occasions contained the following warning in bold type: "*This express must not be delayed and may be expected to run before time.*"

Ivatt "Atlantic" No. 3295 did magnificently on the first test trip, which I did not accompany, and No. 4436 one Sunday created a record by covering the 76½ miles from passing Peterborough slowly to stopping at King's Cross in about 68 min. when working the "Harrogate Pullman." It was then decided to try a "Pacific" of the original "A1" class, fitted with improved valve motion as then standard, and I was privileged to log the run with the assistance of an enthusiastic friend. The engine was No. 2547 "Doncaster," in charge, as on the No. 3295 test, of the redoubtable Driver Bill Sparshatt, with A. E. Smith as Fireman.

We made a fast start, attaining 76½ m.p.h. on the Holme level, and while going up the 1 in 200 Stukeley bank at about 66, "even time" was reached, 12½ miles from the start in 12½ min. From Huntingdon, passed at 82½ m.p.h., the 27 miles, mostly against the engine, to Hitchin took no more than 21½ min., with no speed lower than 71½ m.p.h. We passed Cambridge and Midland Junctions at the north end of Hitchin Yard at 73 m.p.h., when the long rise to Stevenage had steepened from 1 in 264 to 1 in 200,

and we assured ourselves delightedly that never before had an up express sailed through Hitchin at 73-74½ m.p.h. The minimum up to Stevenage was 67-47½ miles passed in 40½ min. Thence, over the 21 undulating miles to mile-post 7½, No. 2547 ran very fast at an average of 79 m.p.h., getting up to 88 in the dip before Hatfield, whence the five miles of broken climb to Potters Bar took only 3 min. 48 sec., with a minimum of 75. Then down the bank speed rose rapidly. As we sped along the embankment at the southern end of Hadley Woods, our stop watches registered 90, 91 and 92, and then my friend shouted "93," as we tore through the important suburban station of New Barnet like a veritable tornado!

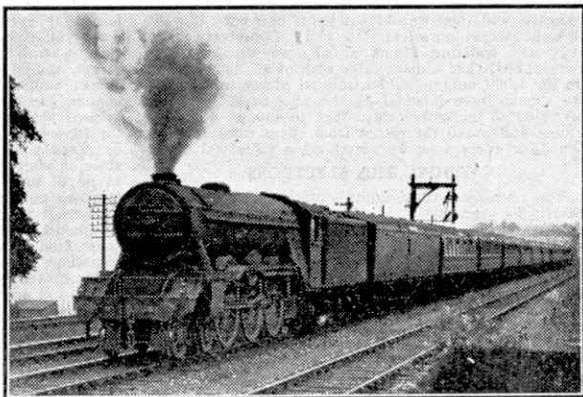

The 1.5 p.m. down Saturday relief Newcastle express near New Barnet. The engine is Class "A3" 4-6-2 No. 2595 "Trigo." Photograph by C. Stevens.

"Doncaster" was still accelerating, and had circumstances permitted might have nearly reached a three-figure speed before the foot of the bank was reached; but steam had to be shut off because less than three miles away it would be necessary to come down almost to walking pace over a new bridge under construction. We emerged from Oakleigh Park tunnel, at mile-post 7½, at 82, having then covered 69 miles from the start in 56½ min., averaging 73 m.p.h. Brakes were put hard on in order to bring speed down to about 10 m.p.h. over that wretched bridge.

Acceleration was terrific once the last vehicle, a fish van that must have been having a pretty hectic trip, was across the new bridge. With a staccato roar from the exhaust at first No. 2547 worked up to 56 m.p.h. in the 1½ miles to Wood Green; then 2½ miles further on, with the regulator still open, she passed the busy inner-suburban junction of Finsbury Park at 69. More thrilling still was the 75 past Holloway North Down Box, 1½ miles from the terminus, and close to the beginning of the 1 in 105 drop down to King's Cross! A fast though comfortable descent was made through the tunnels and we drew up at No. 1 platform at 3.57. The overall time for the 76½ miles was 66 min. 10 sec., but allowing for the severe slack the net time was no more than 62½ min., representing a start-to-stop

speed of 73½ m.p.h. This constituted a record between these points that still stands.

In 1927-8 the late Sir Nigel Gresley rebuilt five 4-6-2 locomotives of the original "A1" type, first introduced in 1922, with a boiler pressure of 220 lb. per sq. in. instead of 180, and considerably enlarged

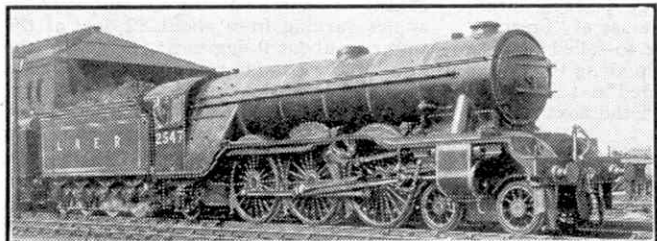

The "Pacific" engine "Doncaster," which made the Peterborough-King's Cross record run described in this article.

superheaters. Four of these retained their 20 in. cylinders and were officially re-classified "A3/1." The remaining engine, No. 2544, "Lemberg," as an experiment that would keep the theoretical tractive effort practically the same as on the "A1's," had her cylinders lined up to 18½ in. in diameter, the stroke of 26 in. being retained. She became the sole representative of class "A3/2" and in the able and enthusiastic hands of Driver C. Molson created a reputation as the fastest "Pacific" at Doncaster shed, and one of the speediest on the G.N. section generally until the coming of the streamliners.

"Lemberg" and Molson were the "star turns" of two of my red-letter runs. One of these was on the 7.50 a.m. breakfast car express from Leeds to King's Cross, for many years one of the principal services on the West Riding route in normal times. This train was one of the quickest of the day and was known in railway travel circles as the "Breakfast Flyer," a nickname that I believe I originated.

On a stormy Monday morning when a heavier load was inevitable I was waiting at Grantham to join this train in high hopes of logging a fine run. The foreman came along and said: "Are you for London, sir?" Receiving an affirmative reply from myself and others, he told us that the express had left Retford full, and that if we would get into the corridor coach standing in the bay it would be attached in rear. We did as bidden, very comfortably, and a 4-4-2F was hauling our coach out on the up relief line when the express ran in, so that I was able only to glimpse "Lemberg" and Molson, but I counted up the load. "Gosh!" I said to myself, "12 on, fully 400 tons already, and there is a strong oblique S.W. wind with portending rain." Our coach was attached and coupled up; we were off, 3 min. behind time with, I felt certain, at least 435 tons gross load.

The first 5½ miles are all uphill at 1 in 198. No. 2544 gradually got up to 43 m.p.h., passing Stoke Box just north of mile-post 100 from King's Cross in 8 min. 40 sec. There now followed a very fast descent of the famous Stoke bank, as the worthy driver was anxious no doubt to get a minute or two in hand. In three miles, at the foot of the 1 in 178, speed was 73 m.p.h., and on the long 1 in 200 we were up to 90 soon after Bytham. Through Essendine,

where the gradient is flattening, our rate of travel hovered around 91-92 m.p.h., being highest in cuttings and slightly lower when the adverse wind caught the train. Past Tallington speed was a steady 88; at Werrington Junction, where the East Lincolnshire line comes in, it was 83½, and we had then averaged 86½ for 17½ miles! Directly after passing mile-post 78 at 79 m.p.h., brakes went on as we passed the busy New England Marshalling Yard and Shed, because Spital Junction signals were against us, and they did not go off until speed was down to about 10 m.p.h. Then we were checked again before passing through Peterborough station at 15-20 m.p.h. Even so the first 29 miles had taken barely 28 min., thus giving a much needed minute in hand.

The performance of No. 2544 over the undulating road thenceforward was superb. Indeed, considering the load and bad weather it was a far finer achievement than that of No. 2547 on test 18 months previously in the run I have already described, thus demonstrating the effectiveness of the higher pressure and drier steam, as well as the incentive and enhanced driving prowess that the accelerations had produced. The wind was felt severely, blowing across the fens as the long 1 in 200 Stukeley bank was ascended; the minimum was 55 m.p.h. After Huntingdon there was less trouble from wind, but showers were frequent. With no lower speed than 71½ over St. Neots "hump," the 17½ miles to Biggleswade were run at an average of 75, but now came a cruelly long permanent way slowing. Over ¼ mile had been relaid on the previous day and the whole length of new track was traversed with scrupulous caution in driving rain. This severe set-back affected the running right on to Stevenage summit.

It was not possible to keep the very fast overall time now, but Driver Molson was evidently determined

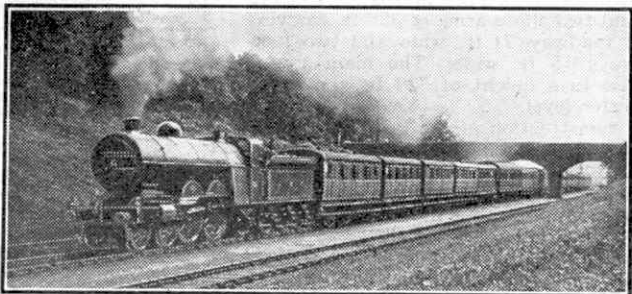

Ivatt "Atlantic" No. 301, in G.N.R. lettering and numbering. This engine is now L.N.E.R. No. 3301. Photograph by W. Beckerlegge.

not to be a second later than he could help. He urged "Lemberg" up the long 1 in 264-200 rise, in torrential rain, at an average of 52 m.p.h., with an absolute minimum of 50. Then beyond Woolmer Green came an exciting "dash for home." After logging a maximum of 84 before Hatfield, I was privileged to record one of the most brilliant little ascents up the 1 in 330-200 to Potters Bar that I ever experienced or heard of under comparable circumstances. The five miles were covered in 4 min. 7 sec., with a minimum of 70 sustained up the last 1 in 200 to the top. Such (Continued on page 106)

Creepers Cranes for Bridge Building

ONE of the most interesting features of the building of large bridges during recent years has been the use of "Creepers" cranes. These cranes are so-called because they are designed to creep along the bridge structure as it is completed and hoist into position the steelwork in the next section to be erected.

The construction of the main arch span of the Sydney Harbour Bridge, the largest arch bridge in the world, was carried out by means of two creepers cranes each of 122 tons lifting capacity, designed and supplied by The Wellman Smith Owen Engineering Corporation Ltd., London and Darlaston, England. The construction of the arch proceeded simultaneously from the two shores, the cranes moving up the main booms as erection progressed, and, in effect, laying their own tracks.

Following this outstanding achievement The Wellman Corporation were commissioned to design and construct suitable crane equipment for the erection of the great Howrah Cantilever Bridge across the Hooghly River in India. This bridge, designed by Messrs. Rendel, Palmer and Tritton, of London, and built by The Cleveland Bridge and Engineering Co. Ltd., Darlington, England, consists of a cantilever structure with a central span of 1,500 ft. and two shore arms of 325 ft. carrying a roadway 71 ft. wide and two footways 15 ft. wide. The main towers rise to a height of 320 ft. above low water level.

Construction of the bridge, embodying 35,000 tons of steelwork, proceeded simultaneously from the two sides of the river, a creeper crane of special design being supplied for use on each side. One of these fine cranes is shown in our cover picture, which is based on a photograph kindly supplied by The Wellman Smith Owen Engineering Corporation Ltd. Each of these units was of a composite nature, comprising two 60-ton slewing and derricking jib cranes mounted on a main frame structure designed to travel along the top chords of the bridge. The main problem confronting the crane builders was to devise a means whereby these load lifters, each weighing with cradles 740 tons, could be made to mount the chords of a shore arm lying at an angle of approximately 30 deg. to the horizontal, pass over the

apex of the tower and descend the main cantilever chords of the central span at angles varying from about 22 deg. at the tower to about 9 deg. near the end of the arm, finally passing on to the level surface of the suspended span.

In order, therefore, to form a path along which the crane could move, "fleeting tracks" were provided, placed on the

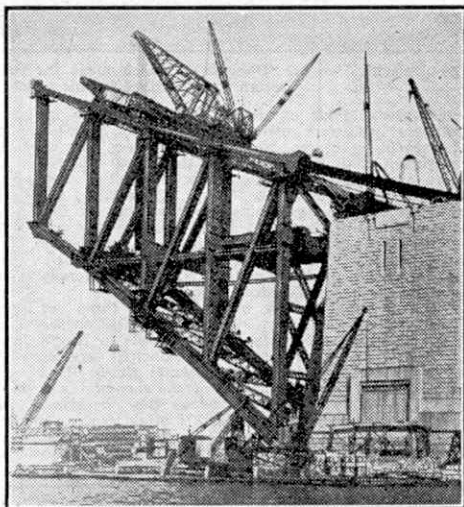

One of the two giant Creeper Cranes of 122-tons lifting capacity, each weighing over 600 tons, supplied for the erection of Sydney Harbour Bridge, by The Wellman Smith Engineering Corporation Ltd., to whom we are indebted for our illustrations.

bridge chords. These tracks, consisting of heavily stiffened box girders, were laid in front of the crane and after it had run forward those it had left behind were picked up and relaid in front. The same tracks were used on the anchor arms as on the cantilever chords, but to provide for the steeper angle of inclination of the former, a cradle was interposed between the anchor arm and the crane proper. The upper surface of this cradle was designed at such a slope that the crane could run off it on to tracks laid on the first section of the cantilever arms when the apex of the tower was reached. The cradles were thus only in use for the erection of the anchor arms, but the "fleeting tracks" were used throughout.

As already mentioned, each undercarriage

carried two 60-ton cranes lifting the full load at 40 ft. radius (or 30 tons at 60 ft.). Each jib also had a 20-ton hoist with a maximum radius of 90 ft. The latter had a change speed gear for light loads up to 5 tons. This auxiliary hoist was also used to give a steadying pull when long members were being lifted by the main hoist, the gears being mechanically interconnected to ensure correct synchronism.

Both gears were then driven by the main hoist motor and the auxiliary hoist motor was declutched. An interesting feature about this motion was that, on account of the great height of lift, which at the maximum was 459 ft., the rope was wound in three layers and a reeling gear provided to lay the rope accurately on the barrel. This feature was of real importance since the increase in effective diameter of the barrel from layer to layer could appreciably alter the relative position of the two hooks if the winding were not accurate.

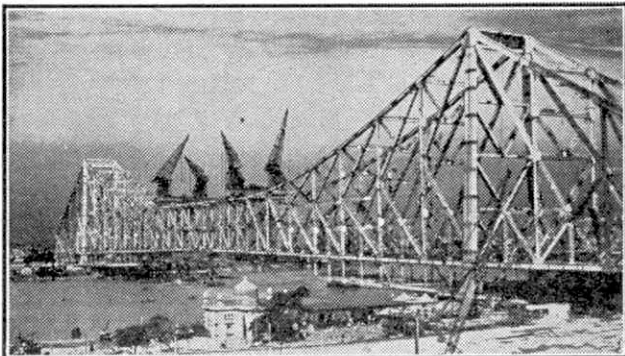

The Howrah Bridge in the final stages of erection.

Overload safety protection was provided on the hoist gears, and in addition to an electro-magnetic brake, a powerful foot brake was provided capable of easily and accurately handling the full load. Interlocks between the auxiliary hoist and the synchronising gear between the gears ensured safe manipulation.

The derricking gear was of the screw type, using heavy steel screws cut with buttress threads. The ends of the screws were fixed to the base of the jib, and heavy bronze nuts holding the screws were held in a cross beam trunnioned in the superstructure. To this beam the operating motor and gearing were attached. The slewing gear was of normal type, but fitted with a clutch to enable the crane to slew freely when standing idle.

The undercarriage on which the two jib cranes were mounted was moved by means of a haulage system, which also travelled the cradle when that was in use on the anchor arm. This haulage system also was an interesting feature, and consisted of winches mounted on the undercarriage, each winding four ropes. The ropes formed two duplicate sets, one on each side of the bridge, and were led over suitably placed sheaves on the carriage and cradle and anchored to a crosshead on the "fleeing tracks." When on the slope, powerful and reliable braking was necessary, and this was provided by pumps delivering oil pressure against adjustable valves. This provision permitted very accurate control.

When the crane was on the level part of the run, that is, on the suspended spar, one of the duplicate sets of hauling ropes with winches was dispensed with in order to reduce weight, and the remaining set of hauling ropes was used as a controlling medium while the crane (Continued on p. 106)

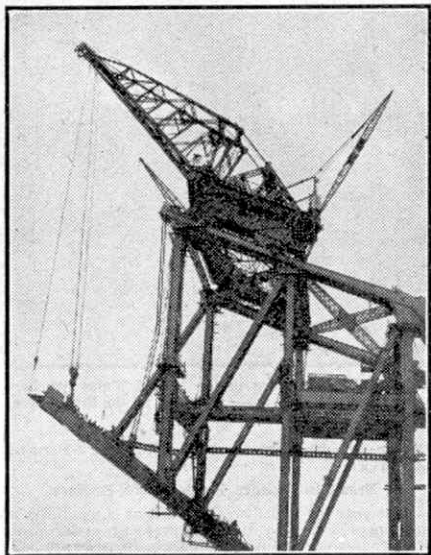

A closer view of one of the Creepers at work on the Sydney Bridge.

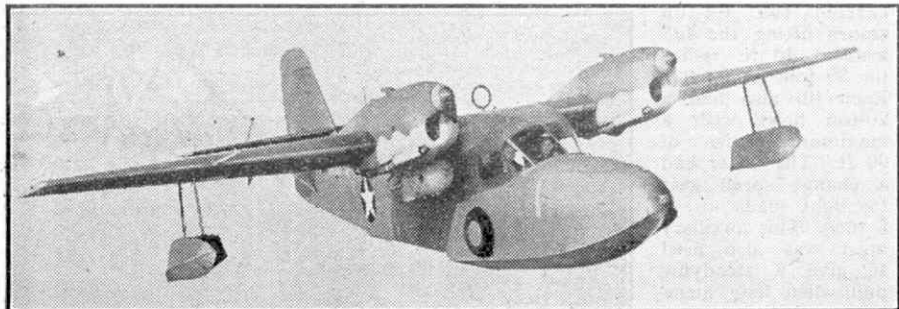

The Grumman "Widgeon" amphibian. In the R.A.F. it is known as the "Gosling." Photograph by courtesy of The Grumman Aircraft Engineering Corporation, U.S.A.

Air News

Grumman Amphibians

Two little known aircraft are the Grumman "Goose" and "Gosling" amphibians, in service with the R.A.F. for air-sea rescue and communications duties, and with the U.S. Army Air Forces under the names of "Grey Goose" and "Widgeon," respectively, for coastal patrol work. The "Widgeon," a smaller version of the "Grey Goose," is a 4 or 5-seater, and, as the photograph above shows, has been adapted to carry bombs for anti-submarine patrol work. It is fitted with two 200 h.p. Ranger engines, and appears to be carrying a bomb of about 500 lbs. weight, a very creditable achievement for such a small machine. The "Widgeon" has a wing span of 40 ft., and at an all-up weight of 4,500 lbs. it has a top speed of 163 m.p.h.

The "Grey Goose" with its two 450 h.p. Pratt and Whitney "Wasp Junior" engines, has a top speed of 201 m.p.h., and can carry a fixed forward-firing machine gun and a movable gun on a mounting above its turtle-deck.

J. W. R. TAYLOR.

New British Transports

In the House of Commons recently Lord Beaverbrook mentioned that two of the new types of British air liners now being built under the "1943 Charter" will be known as the Avro "Tudor" and Bristol "Brabazon" respectively. The former is to be a 32-ton 4-engined transport, designed along conventional lines and with a wing span of 122 ft. It will be able to make transatlantic flights with 12 passengers, their luggage and a load of air mail. The cruising speed of this machine will be about 220 m.p.h. The "Tudor" should be flying long before the 100-ton "Brabazon," which is intended to carry 50 passengers across the Atlantic in great comfort.

Recent Bristol advertisements in the technical press have given some idea of what the "Brabazon" will probably look like. They show a graceful low wing monoplane, with four contra-rotating pusher airscrews driven by eight large radial engines completely enclosed in the wing and intended to give a combined output of some 20,000 h.p.

The "Brabazon" and the "Tudor" are but the forerunners of a series of new designs that may not be flying for another 3 to 5 years, but which will ensure that post-war British air-lines will have the finest equipment in the world. J. W. R. TAYLOR.

American Post-War Air Line Plans

One of the big American air line companies making ambitious plans for extending their operations after the war is American Export Airlines, which, after many setbacks, obtained a license to operate a transatlantic air service from New York to Foynes in the summer and to Lisbon during the winter months. This Company have applied to the Civil Aeronautics Board for permission to operate a North Atlantic air service between Washington, D.C., and Bombay, India, with calls at Foynes, Paris, Rome, Athens, Cairo, and Karachi, and a South Atlantic service between New York and Capetown by way of Puerto Rico, Trinidad, Natal, Dakar and Algiers. In addition permission is being sought to establish a branch air service from Athens to Istanbul, Bucharest and Sevastopol.

The latest news of this Company's plans is that application has just been made to the Civil Aeronautics

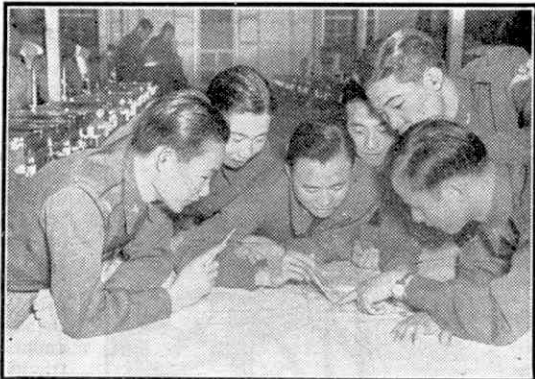

Chinese flying cadets being trained in the United States are here shown mapping a cross-country flight as they lie on the floor of their barracks.

Board or a license to operate a New York-Bermuda air service.

Brazil to Produce Ranger Aero Engines

Last year the Brazilian Government entered into an agreement with the U.S. Government under which Ranger aero engines of up to 200 h.p. are to be produced under license in Brazil. It has just been announced that production of the engines will begin there at a new Government factory near Rio de Janeiro on the 19th April next, the birthday of President Vargas.

Improved "Lancaster" Bomber

Shortly after the appearance of the Avro "York" freight transport it was announced that the "Lancaster" heavy bomber, from which the "York" was developed, is in production with four Bristol "Hercules" XVI engines instead of the familiar "Merlins." This means an increase in power of about 1,500 h.p. Other modifications to the "Lancaster"

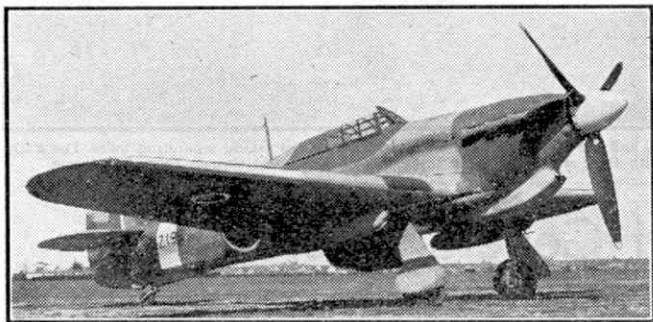

An "improved" Hurricane Mk IIb tank-buster with "Merlin" 32 engine, giving increased power low down. Note the deeper radiator bath. Photograph by courtesy of Hawker Aircraft Ltd.

include the provision of an extended bomb bay capable of housing the largest bombs at present in general use. The maximum bomb load is somewhere in the region of 8 tons, although loads are considerably smaller than this on a long-range operation. The top speed of the "Lancaster" II is still secret, but is known to be well above 300 m.p.h. J. W. R. TAYLOR.

British Overseas Airways News

Last year aircraft of British Overseas Airways flew a total of 12,500,000 miles, equal to 500 times round the world or $1\frac{1}{4}$ times round it every day of the year. This impressive mileage was 25 per cent. more than that flown during 1942. The total number of passengers carried in 1943 is given provisionally as 65,667, almost one-third greater than the number flown during the previous year.

The Corporation are now operating about 50,000 miles of air routes. Probably the best known of their

wartime services is the North Atlantic Return Ferry which operates in both directions over the 3,200 miles between the United Kingdom and Montreal, and takes delivery pilots and crews of Transport Command, R.A.F., back to Canada. On their eastward, or return, flights the machines carry Government passengers and freight. British Overseas Airways also operate a transatlantic air service between the United Kingdom and Baltimore, U.S.A., services from the United Kingdom to West Africa and Egypt, and two trans-African services. There is also the 8,000-miles Durban-Calcutta air service by the "Horseshoe" Route, flown with "Empire" flying boats, and an important network of services from Cairo through the Near and Middle East.

The great fleet of aircraft used by British Overseas Airways now totals just over 100 machines. The British types include the Armstrong Whitworth "Ensign," D.H. "Flamingo" and modified "Mosquito" landplanes, and "Empire" and modified "Sunderland" flying boats. American types of aircraft used by B.O.A. include Boeing 314As, Consolidated "Liberators" adapted for civil operation, Douglas "Dakotas" of various Marks, and several versions of the Lockheed 18 "Lodestar" transport. An early addition to this varied list will be the Avro "York," the new British 4-engine transport.

Another Canadian Government Transatlantic Service

The twice-weekly transatlantic air service operated by Trans-Canada Air Lines for the Canadian Government, mainly for the rapid transport of mail to and from Canadian Forces in the United Kingdom, is to be supplemented by a similar service operated by the Royal Canadian Air Force, and for which R.C.A.F. crews are being trained. A new Transport Command of that Force is being created to deal with transatlantic flights on which mail is flown to Canadian Forces in the United Kingdom and the Mediterranean zone.



Consolidated B-24 "Liberator" bombers lined up in front of two of the 17 hangars used by the Lockheed Overseas Corporation at a base for repairing, servicing and altering all types of American aircraft. Photograph by courtesy of the Lockheed Aircraft Corporation U.S.A.

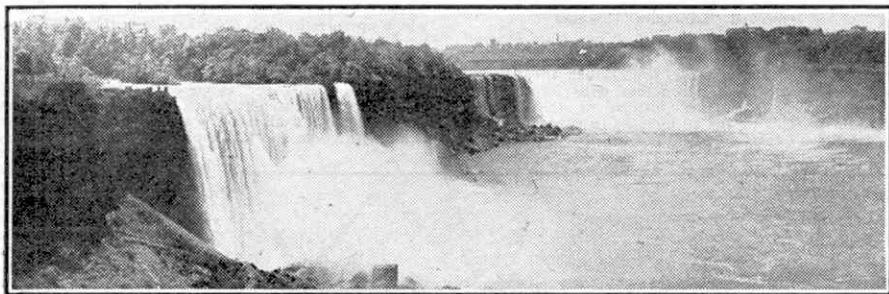

The American Fall, on the left, and the Horseshoe Fall at Niagara, with Goat Island separating them. The Falls are low in comparison with their width, but only three falls in the world surpass them in volume.

Of General Interest

How Waterfalls are Made

The spectacle of water pouring over a ledge or cascading down a hillside, whether to the accompaniment of a thunderous roar or a pleasant burbling, inevitably is attractive to all of us. Few stop to wonder how falls originate, however. Most of us think that the ledges or precipices were there to begin with, and rivers have been compelled to flow over them on their way to the sea. This is not the case; the water often creates for itself the scenes of its leaps.

Waterfalls have carved out their courses in various ways. For instance, a river may pass over some ledge of specially hard rock that it cannot wear away so quickly as the rest of the bed over which it flows. Then the hard ledge remains while the softer material beyond it is eroded, so that a ledge is created over

which the water plunges. Niagara is an example of this. Other waterfalls are the result of breaks or falls in rock strata, the Yosemite Fall in California being of this type. Yet another way in which waterfalls are created is by the formation of great chasms or fissures by earthquakes. The Victoria Falls in Southern Rhodesia are of this kind, the water of the Zambesi River leaping down into a great gap in the hard rock that forms its bed. Sometimes too the course of a river is blocked up by boulders and stones, and then the water rises up behind the mass until it overflows.

The Highest Fall in the World

Whenever we think of waterfalls the mind immediately turns to Niagara. Yet this is not in the first 14 as far as height is concerned, and there are certainly three others that exceed it in volume, immense as the flow of water in it is. The highest in the world is Ribbon Fall, in the Yosemite

Valley, which is 1,600 ft. in height, but it is closely followed by the Yosemite Fall, which has a leap, one of three totalling 2,565 ft., that measures 1,430 ft. British Guiana figures prominently in the list of the highest falls in the world. The best known of three in that country is the Kaieteur Fall, a gigantic cataract 741 ft. high; but there are two other falls with heights of 1,200 and 840 ft. respectively. Although Niagara is not in the list, Canada is represented by the Takakaw Fall, which is 1,200 ft. in height; and in New South Wales there is the Wollomombie Fall, with a total drop of 1,700 ft., and one leap of 1,100 ft.

As far as volume is concerned the world's greatest cataract appears to be the little known Khom Fall, in Indo-China, which has a width of 42,000 ft. In Brazil there are the Guayra Falls, with a width of over 15,000 ft., and then follow the Victoria Falls and Niagara with widths of 4,500 and 3,900 ft. respectively.

The British Isles are not the home of great waterfalls, but there is one British fall more than twice the height of Niagara! I wonder how many readers know its name and position. It is the fall of Glomach, in Rosshire, Scotland, which is 370 ft. in height, but of course is not so massive or spectacular as the famous American fall.

Bees Never See Red!

It is curious to find that bees have no sense of red, although they are able to distinguish other colours. Certain colours with red in them do make an appeal to the bee's sense of sight, however, cinabar and purple-red to them looking dark brown and dark blue. Of the colours that are properly within their range, they get very different ideas from those we have. For instance, whites take on various appearances for them, white lead paints seeming white or pale grey, while zinc white looks blue-green.

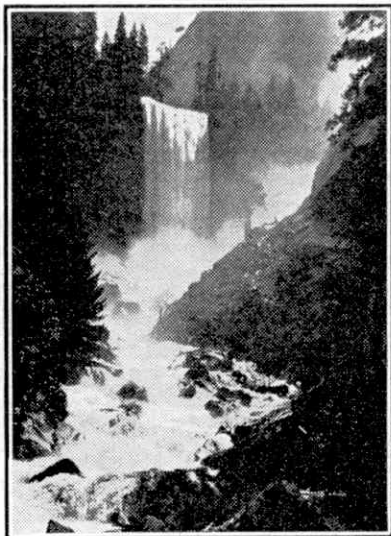

The Vernal Fall, 350 ft. high, in the course of the Merced River, Yosemite Valley, California.

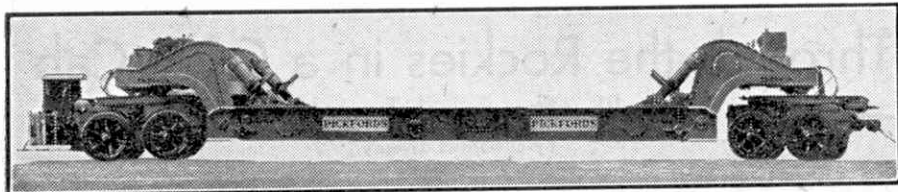

The unique vehicle seen in this illustration is believed to be the largest capacity road trailer in existence. Its overall length is 61 ft. and it is intended to deal with loads of 120 to 140 tons. It will be used chiefly for the transport of transformers. Photograph by courtesy of Cranes (Dereham) Ltd.

Engineering News

Road Trailer to Carry 140 Tons

The illustration at the head of this page shows one of two giant trailers for unusual loads that have been built for Pickfords Ltd. by Cranes (Dereham) Ltd. This is believed to have a larger capacity than any road trailer ever built. It is designed for loads of 120 tons to 140 tons and has a length of 61 ft., with a wheelbase of 44 ft. 2½ in. and a 24 ft. loading deck.

The trailer can be hauled from either end as desired, and it can even be moved bodily sideways. It is carried on two bogies, each with eight wheels. The two ends are identical. Both can be steered, and when the vehicle is on the move the rear end is controlled by a tractor, exactly as the front end is. When a second tractor is not available, however, or if there is no room in which to use one, the steering can be done by hand, and a special platform is fitted for the steersman in charge; while the rear wheels can be locked in line with the main frame if desirable, the vehicle then being steered by the front end only.

The general construction of the trailer will be evident from the photograph. The main frame is built up of girders of box construction, with ample cross members of great strength to ensure rigidity. At each end is a "swan neck," so called from its shape, which rests on the corresponding bogie and is hinged to the ends of the main girders of the frame. In addition the upper end of each swan neck is connected to the main girders by hydraulic jacks. A petrol engine and pump is provided at each end to operate the jacks, and the effect of this is to raise the girders from their least height of 2 ft. 3 in. to their greatest of 5 ft. 1 in., an operation that can also be carried out by hand. The ability to place the loading platform at any desired height within this range is a very great advantage, and in addition the load can be lowered when necessary to pass under low bridges, or raised when hump-backed structures have to be crossed.

The eight wheels of each bogie are fitted with 771 mm. by 15 in. solid rubber tyres, and there are four axles to each bogie. All the wheels are equipped with hydraulic brakes having shoes of 20 in. diameter and 4 in. width.

Fighting Rust on the "Lafayette"

One of the problems met with in salvaging the "Lafayette," formerly known as the "Normandie," was that of preventing damage by rusting, especially in the case of the engines. The danger arose as the water in the hull of the vessel was pumped out. Immersion in deep water does not cause serious rusting, as there is little free oxygen there, and this gas is essential for rusting. Exposure of the wet machinery to the air would have caused rapid corrosion, however, and a special form of treatment therefore was followed. The parts to be protected were sprayed as soon as they emerged from the water with special oils that penetrate water in contact with metal,

spreading out over the surfaces and actually pushing water away from them. Thus they form a protective coating, excluding both water and oxygen.

How effective the process was in salvage work on the "Lafayette" is shown by the fact that only one turbine shows damage from corrosion, and this is one that was alternately in air and water several times before it could be treated. Even the gyroscopic compass, a delicate and complex mechanism, was so successfully protected by this treatment that only two parts and the motor had to be replaced. Hundreds of tons of metal equipment of all kinds, from the pans in the kitchens to the main turbines and motors, were preserved for use again in the vessel, with an immense saving of cost and manufacturing time.

A British Salvage Achievement

An outstanding example of successful salvage in Great Britain has been the raising of the hull of H.M.S. "Caledonia." This vessel was a naval training ship, stationed in the Firth of Forth, and was more familiar as the "Majestic," the name she bore for many years while in the Atlantic service of the White Star Line. She was built in Hamburg and was handed over at the end of the last war to be completed by the British company. Until the coming of the "Normandie" she was the largest ship in the world, with a gross tonnage of 56,000.

In the early days of the war the "Caledonia" was badly damaged by fire, and sank after being towed out to what was thought a safe anchorage. It was decided to refloat her in order to make use of the immense quantity of scrap metal that she would give. Part of the vessel projected above the water, and this was dismantled, yielding over 8,500 tons of steel. All cracks, portholes and inlets of all kinds in the hull were then sealed, much of the work necessarily being done under water by divers; and a battery of pumps driven electrically and by steam was brought into play to remove the water, the system being capable of dealing with 10,000 tons an hour.

The ship was afloat again after about nine months' work. The task of removing steel from her was then continued for a time, after which the remains of the hull were towed to a ship-breaking yard. About 14,000 tons of steel have been obtained already from the ill-fated vessel.

Mass Production of Light and Power

The hydro-electric generators of the Coulee Dam recently produced sufficient current throughout a 24½ hr. period to illuminate two 60 w. bulbs in every home in the United States. The actual production was 16 million kilowatt-hours, and stands as a record. The whole of the vast production of the power units of the Coulee Dam scheme is used in the homes, factories and workshops of the north western States, bordering on the Pacific Ocean. The Dam itself is three times the size of the Great Pyramid.

Through the Rockies in a C.P.R. Cab

III—The Spiral Tunnels

By Edward H. Livesay

BEAVERMOUTH lay at the foot of a 1,345-ft. drop in the 18 miles from the Connaught Tunnel, and brought a stop for water. The Columbia valley opens out here, and stretches of level and lengthy straights made higher speeds possible. Over 50 m.p.h. was reached at times, and the gale swirling past banished the last traces of Laurie sulphur from my lungs, pumping me full of oxygen and making me sleepy. Awakening suddenly as we rounded a bend in a cutting,

and with the blast of cylinder-cocks in my ears, I was just in time to see a great glossy-black bear lumber hurriedly off the track and up the bank, showing snarling white teeth as he went. Brier had opened the cocks to scare Bruin from the path of our Juggernaut rather than whistle, which presumably might have misled the Conductor. Deer I had seen several times, leaping gracefully away into the bush; mountain goats, too; beaver, busy on their dams, and squirrels galore, skittering up trees; eagles, making great lazy circles high in the central blue. It was all very fascinating, but locomotives are our business, not ornithology, so let's get back to them!

Golden was the next stop, where we picked up the Kicking Horse river and another pilot to help us up the heavy climb to Leancoil, a 2-10-0 somewhat old and well-stricken in years, but nevertheless a very present help in time of trouble, which we might have run into had we tackled this stretch unaided. I stayed with good-riding 5926, the action of our ancient

leader looking a bit turbulent; curvature was incessant through this wilderness of rock and torrent as we neared the Rockies, seen ahead as another and final wall barring our way to the prairie. It is only 18 miles to Leancoil and here the pilot came off though the gradient went on to Field, but moderated, and within the compass of 5926 unassisted. This is the fourth and last B.C. Divisional point, in the heart of the Rockies, nestling at the foot of Mount Stephen, with other giants, Ogden, Cathedral, and so on, soaring up all round. We had only averaged 22 m.p.h. over the 35 miles from Golden, but considering we had climbed 1,489 ft. in the distance, and were now 4,072 ft. above sea level, you need not be contemptuous. You should see the profile and the surroundings—then you would understand the reason why!

Putting our watches on an hour, "The Dominion" pulled out at 3.25 p.m. headed by 5926 and a big 2-10-2 pilot, with the culminating 14 mile 1,265 ft.

pull up through the famous Spiral tunnels to the summit, "The Great Divide" at Stephen, in front of it. Unique in North America, these tunnels merit description. When the C.P.R. was built in the 80s the Kicking Horse Pass was chosen as the best route through the Rockies, though it meant a four mile 1-in-22 descent, "The Big Hill," over which trains were worked for many years with great difficulty and expense. Finally it was

decided that the gradient simply had to be reduced, and Schwitzer, the engineer, worked out a better location. Clearly if an incline between two points is to be reduced there is only one way to do it—by lengthening it; but the Kicking Horse Pass being narrow, zig-zagging was impossible. So "doubling back" had to be the scheme, and two spiral tunnels driven under the near-by mountains, Ogden and Cathedral, a method often adopted in Switzerland and other rugged countries. Thus four miles of 1-in-22 became eight miles of 1-in-45, the gradient being still further reduced in the tunnels to 1-in-62, to compensate for the increased friction due to pulling the trains round the curves. Work began in 1907, the tunnels being driven from both ends simultaneously through water-bearing fissured limestone—I proved this at some discomfort in 1942 when "riding the front end" through the Spirals, getting unexpected shower-baths—and was completed in 1909. The new layout enables an engine of given power to haul three times the load it could have done

previously over "The Big Hill," and runaways are not likely to occur. Schwitzer did not live to see the completion of his work; I think a plaque should have been put on the portal of one of the tunnels, similar to Wren's splendid and appropriate epitaph in St. Paul's Cathedral: "If you seek his monument, look around."

Away from Field we climbed steadily higher and higher into the mountains round incessant curvature as the valley narrowed to the climax, and plunged into the lower Spiral. Total blackout at once, with choking heat and sulphur fumes, plus a thunderous roar from the two great engines stretching their thews and sinews with 1,200 tons behind them. Beastly—decidedly unpleasant! I was on the second engine, which made things all the worse. Trains have been known to stall in these tunnels, and as they are unventilated, crews have been "flaked out" as a result. With eyes and mouth tight shut, and a bunch of waste held over my face, I suffered tortures until

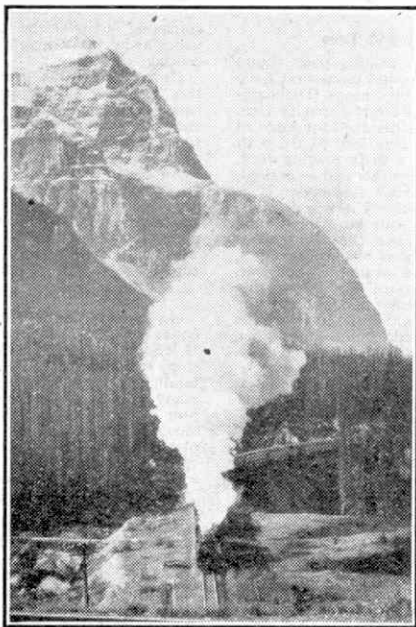

Train entering the lower Spiral under Mount Ogden. Mount Stephen is in the background.

we burst out into the open—the lower Spiral was past, thank goodness, and a breathing space ahead, literally. Over the Kicking Horse river, still climbing and into the upper Spiral, where things repeated themselves; out into the purity of mountain air and sunshine reflected from dazzling white

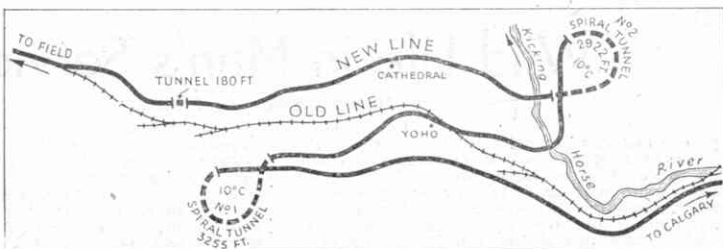

Diagram showing the course of the old line and of the new line with its spiral tunnels.

peaks standing out against blue sky. As the cab cleared of smoke and fumes I stood in the open door looking back down into the Kicking Horse valley, tracing the tangled course we had followed, to see our steam still lazily curling up from the mouths of the Spirals, and Field crouching at the foot of majestic Mount Stephen, the finest and most inspiring view, I always think, in the Rockies—at least, to a railway! And then on to a stop at Stephen, where the pilot came off, 4.12 p.m., the 14 miles from Field having taken 47 minutes, 18 m.p.h., raising us 1,265 ft. to the "peak" of the trans-Canadian route, 5,337 ft. above sea level at Vancouver, 519 miles from our starting point. From Stephen right away to the Atlantic, a matter of roughly 3,000 miles, there are no more mountains to cross, or any really heavy gradients to climb.

Incidentally, it is curious to note that there are heavier inclines on a British main line than any we have tackled in the Selkirks or Rockies. I made a trip on the "Cornish Riviera Limited," "King William III," just before the war, to Plymouth, and back on the "Castle," "The South Wales Borderers," and was amazed to find from my gradient book that between Newton Abbott and Plympton we were mastering such pitches as 1-in-36-41-42, the latter being a mile-and-a-half long, the Hemerdon Bank. The C.P.R. has nothing worse than 1-in-45 in B.C.

But to resume; at Stephen we are astride the ridge of the Continental roof, proved by a little rivulet that runs under an archway at the trackside, "The Great Divide," and then forks, one half being directed into the Pacific, via the Kicking Horse and Columbia rivers, and the other into the Atlantic via the Bow, Saskatchewan and Hudson Bay. "A quaint conceit!" We halt alongside to grasp this fact, that water runs downhill, and will go on doing so until it is stopped.

Over the top, and the best of luck—downhill practically all the way into Calgary, 123 miles, and 5926 speeds up, her 5 ft. 3 in. wheels turning over faster and faster, making 60 m.p.h. at times, at which the riding is roughish. Small drivers and tremendous coupling

and connecting-rods are not really happy at such velocities, eased though they are by flange-lubricators. Near Lake Louise the explosion of torpedoes (that is detonators, fog signals) brought "The Dominion" to a stand, a red-flagged sectionman (plate-layer) reporting a broken rail ahead. We negotiated it on tip-toe at 5 m.p.h. Steel here, by the way, is 130 lb. to the yard, some of it welded.

Then came Banff, the famous mountain summer-resort, and the last stop on the long downhill dash to Calgary. We really began to move now, faster and faster, much of the descent being done at 50-60 m.p.h.; and as we went lurching and swaying down through the foothills I was reminded of the existence of those huge side-rods and massive balance-weights threshing round tied to 63 in. wheels—and looked at them, too, hanging out from the door—imagining the tremendous strain on engine and track, and on the cars swirling after us round the incessant curves. The riding was rough; I was nearly pitched off my seat several times. And now 5926's only defect showed up; at speeds above 50 the cab-floor vibrated

in tune with the throw of the side-rods—or balance weights, perhaps—showing the balance to be a little out. It seems to be personal to this engine, as no other 5900s on which I have ridden had this trait; and once, mentioning it to an engineer well used to the class, forgetting her number, he said: "Ah, that must have been 5926!" Looking up my past notes lo, it was even so.

Nevertheless, she is a fine engine; so are her sisters, and as we ran into Calgary, the tall yellow stone buildings glowing rose-pink in the level rays of the setting sun, I was quite sorry my acquaintance with her was soon to end. "The Dominion" came to a stand at 8.03 p.m., and had covered the 82 miles from Banff in exactly two hours. The whole trip from Vancouver had been fascinating; 641 miles of magnificent scenery, coupled with fine engines, heavy grades, ditto trains, and every kind of interest, physical, operational and human.

Don't you agree with me? Of course. Then make the trip yourself someday, and you'll enjoy it as much as I did!

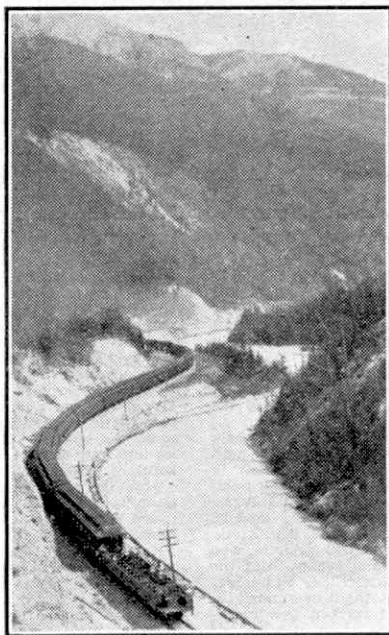

Kicking Horse Canyon and River.

Wild Life in Man's Service

By Harold J. Shepstone, F.R.G.S.

IN our February issue an account was given of the work of the elephant and of how this great creature was employed in the Indian Army and also in the timber yards of Burma. The elephant, however, is by no means the only wild creature that man has tamed and trained to do his bidding. There are the reindeer, water buffalo, yak, llama, and many other creatures, including even birds and fishes.

In the semi-Arctic regions the reindeer is extensively employed for all kinds of purposes. To the dweller in the northland this animal is horse, cow, sheep and goat rolled into one. It supplies milk from which butter and cheese are made; its flesh equals first-class venison; the hide is made into robes, wraps and rugs; the bones are converted into all sorts of tools and implements, while the sinews take the place of cotton and thread. Then it is the recognised beast of burden. A reindeer will easily pull a load of 300 lb., travelling at an average speed of eight miles an hour over the rough, uneven, frozen ground.

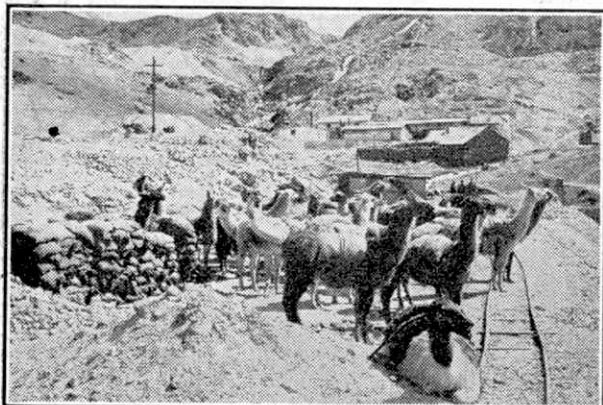

Llamas at a South American copper mine. They are used for carrying stores.

In Alaska reindeer are used for carrying the mails between outlying settlements; and in Lapland the Laps have for years employed reindeer for a similar purpose. The Finns made extensive use of this creature when Russia invaded their country just before the present conflict. They were employed first on evacuation work, carrying women and children away from the mining centres, and later for conveying stores and ammunition to the troops on the various fighting fronts.

The greatest reindeer venture was that recently carried out by the Canadian Government. A herd of some 3,500 selected reindeer was purchased in Western Alaska and driven a distance of 1,500 miles to a specially prepared reserve on the Mackenzie delta. It was the greatest animal trek of modern times, and occupied 5½ years. In the semi-Arctic regions of Canada there are some 6,000 Eskimos, who hitherto have lived by hunting and fishing. But the opening up of large tracts of this territory by mining, and the desire on the part of the Government to protect the remaining herds of caribou and musk-oxen, means that the Eskimo has been deprived of his means of existence. So he is to be taught how to tame and train the reindeer and how to use the

animal for his own benefit.

While the African buffalo is recognised as a wild and dangerous creature, his Asiatic cousin—often alluded to as the water buffalo, from his habit of spending so much of his time in water—has been tamed, and has become one of the most useful servants that man has ever had. He can be found at work in India and Burma, in China and the Philippine Islands. Standing six feet high at the shoulders, and with his two immense horns, he is a picture of massive strength. His ordinary pace is slow and leisurely, but when he is roused he will put his head down and charge with speed and fury. Although outwardly obedient and peaceful, let a stranger come near and he snorts with suspicious dislike.

He works in the great swampy tracts of India and China where rice is grown. Rice, like other crops, has to be cultivated, and the wet ground has to be prepared for it. No horse could pull a plough in

such places, but the slow, mighty buffalo easily does so. His broad hoofs keep him from sinking in the mud, though the latter is often so deep and soft that it closes over his hock. Indeed, for pulling and hauling he is the strongest animal in the service of man—except the elephant. He may often be seen plodding along the banks of a river towing some boat or barge just like a canal-boatman's horse in this country. These unwieldy brutes are controlled by small Indian boys and girls with perfect safety. It is a common sight in India to see a buffalo quietly led along, by means of a thin string attached to a ring in its nose, by a little native girl.

Just as the ancient Hindoos took the buffalo and tamed him, so did the Indians of South America take the llama, and subjugate it to their service. When the Spaniards first entered Peru they found the animal in use as the chief beast of burden. It is essentially a

creature for mountainous regions and is found on the higher ranges of the Andes, from 12,000 ft. to 16,000 ft. above sea-level. The llama treads securely paths so steep that neither an ass nor a mule can keep a footing on them. The burden carried is usually 125 lb. Should a llama, by accident or design, be overloaded, it lies down, and nothing will induce it to move until it is relieved of the excess weight. It can go for a long time without water, and it costs little or nothing to keep as it feeds only on mountain herbage. It defends itself by striking with its fore-feet, and when offended has the disagreeable habit of spitting in the face of the offender.

How the wool of the llama became a great industry is an interesting romance of the animal world. For many years a consignment of 300 bales of this wool remained in one of the warehouses at Liverpool. No one would take it, until a Bradford woollen manufacturer, Sir Titus Salt, decided to experiment with it. By special machinery he was able to make use of the wool, and wove it into the material now known as alpaca. Saltaire, in Yorkshire, was entirely built up upon the wool of this creature.

In Tibet, the yak is found both in its wild state and also in the service of man. It is an odd-looking



How reindeer are harnessed, and the type of sledge used.

beast, its flanks, limbs and tail being clothed with a dense mass of long hair. It is a large animal, standing 5½ ft. and more in height at the shoulders and is strong and hardy. It is extremely impatient of heat, and delights in cold, and is the principal beast of burden throughout Tibet and a great part of Western China and Mongolia. Without the yak it would be impossible to cross many parts of those barren countries. It thrives at an altitude of 14,000 ft. to 20,000 ft. above sea-level.

Falconry is a very ancient sport, and the training of various species of hawks for hunting birds and other creatures is still indulged in, both by sportsmen in civilised countries and by the more backward tribes in the East. But the Mongolians would appear to be the only people who train the eagle to hunt wolves. The golden eagle which the Mongolians use can fly at the rate of 140 miles an hour, and then, folding its wings, drop like a stone upon its prey. It is not such a one-sided contest as it looks, however, and many eagles are lost during their early training. The bird relies not only upon its powerful claws, but on striking its quarry at a vulnerable part of the neck. Should it miss its mark, the chances are that the wolf will get the better of the contest.

A totally different kind of bird from the eagle is the cormorant, but he also is of very useful service to man.

In this country the bird used to be employed in fishing, being trained to bring the fish it caught to its owner; and up to comparatively modern times there was an officer of the Royal household called the Master of the Cormorants. The bird has always been employed in fishing by the Chinese. It is taken when young, and then, with infinite care, taught to catch fish for its owner. A metal ring is placed round its neck, fitting close enough to prevent it from swallowing the larger fish, yet sufficiently loose to allow the small ones to pass down its throat—its reward for working. A sort of harness is rigged about the body of the bird, by means of which it is lowered into the sea and lifted out again into the boat. A cord of spruce fibre, about a dozen feet in length, prevents the bird from straying too far, while it also enables the fisherman to control and guide its movements.

The fishing is always done at night. When all is ready the birds are lowered into the water, and as soon as they have filled their capacious mouths they are pulled into the boat and the fish they have been unable to swallow taken from them. They are then put back into the water, and so the fishing continues. Torches are used to illuminate the scene. It is the light of course that attracts the fish. A well-trained cormorant will catch 100 to 150 good-sized fish an hour—a record that leaves the average human angler hopelessly beaten.

In India otters are used to catch fish for their masters, and are employed also for driving shoals of fish into nets. Even the fish itself has been pressed into human service. In China and elsewhere the remora, or sucking-fish, a sluggish creature which believes in travelling free, and sticks on to any moving object—ship, shark, or what not—by means of a sucking disc on its crown, is requisitioned for catching turtles. A ring is placed round the fish's body, and to the ring a line is attached. As soon as the sucking-fish fastens itself securely to the back of the turtle, both creatures are drawn ashore.

Evidence would go to show that these wild creatures of the plain and the jungle who have been tamed and trained to do man's bidding are perfectly happy and contented in performing their varied tasks and invariably live longer than they would in their wild state.

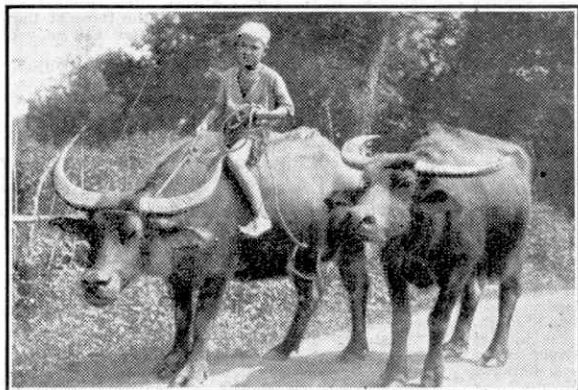

Water buffalo. These animals are employed for hauling heavy loads and for work in the rice fields.

Railway News

Withdrawal of M. and G.N. Joint Locomotives

News is to hand of the scrapping of Nos. 055/6, which were the last "D54" engines as classified by the L.N.E.R. recently. They were large boilered rebuilds of the sole express passenger type, of 4-4-0 wheel arrangement, that had served the Midland and Great Northern Joint Committee so well for over 40 years. Between 1894 and 1899 40 of these were built by outside firms exactly to the long familiar Johnson design on the former Midland Railway, though on account of steep varying gradients with coupled wheels of 6 ft. 6 in. diameter, instead of 7 ft. In course of time all were fitted with extended smoke-boxes. Later rebuildings included the provision of large or small Belpaire boilers, also stovepipe or short chimneys. Those now concerned, with the larger Belpaire boilers, previously known as M. and G.N. class "C rebuild," although of limited size and capacity by modern standards, bravely handled the summer passenger traffic to and from the L.M.S. and L.N.E.R. systems, including heavy corridor trains, at least until 1937; the L.N.E.R. then took over operation of the joint line, and more powerful locomotives began to arrive from their stock.

M. and G.N. engines were at one time yellow, afterwards brown, and carried brass numerals, though they now appear in L.N.E.R. style of livery painted black. Their former numbers have been prefixed by an "0." A good many have recently been withdrawn, so that it is probable that the few remaining 4-4-0s, L.N.E.R. class "D53," "C" rebuilds with small boilers, will soon disappear.

Ten-Coupled "Austerity" Engines

Engines with 10 coupled wheels are being brought into the service on our railways. These are the first of the type to appear on regular main line services in this country, the only previous examples built here being the well known "Lickey Banker" on the L.M.S. and the "Decapod" experimentally built in 1902 by the then Great Eastern Railway, both 0-10-0s. The new engines are 2-10-0s of the "Austerity" type and are being built by the North British Locomotive Co. Ltd. They are Ministry of Supply engines, carrying WD numbers from 3650, and will be loaned to the companies.

Great Western Tidings

More 0-6-0 pannier tanks numbered in the 46xx series have been put into traffic. Engines of this type, old and new, still work local passenger trains a good deal in the South Wales and Midlands regions.

One of the veteran Dean 2-4-0 passenger tank locomotives, No. 3585, one morning lately was piloting 2-6-0 No. 4303, stationed far away at Pontypool Road, on the 9.46 a.m. fast outer suburban train into Paddington, from Henley-on-Thames and Slough. "Castle," "Hall" and "Grange" 4-6-0s, as well as 2-6-0 "Moguls," have been working freight trains regularly over the S.R. electrified track between Reading and Feltham. Southern "Moguls," as reported from time to time in these notes, work trains over the Great Western system in several areas, including the through Ashford-Newcastle service

between Reading and Banbury. The engine on Mr. Churchill's special to London when returning from the Middle East in January was "Castle" class No. 5043 "Earl of Mount Edgumbe."

L.N.E.R. Running News

Of the "H2" class ex-Metropolitan outside cylindered 4-4-4Ts built by Kerr, Stuart and Co. Ltd., those which still remain in service are at work in the Nottingham district, and all but No. 6418 now have the G.C. type of chimney. It is understood that No. 6419 is to be scrapped, so that as No. 6421 is already withdrawn, this will leave six examples of the only 4-4-4 type now to be seen in Britain still on the active list for the time being. These rather imposing looking locomotives have Belpaire fire-boxes, large bunkers, and 5 ft. 9 in. driving wheels.

A considerable number of "04" class 2-8-0 engines of the former Great Central standard type adopted for Government use during the last great war have recently come back to the Southern Area from Scotland, also from loan to the G.W.R.

New 2-cyl. 4-6-0s of class "B1" are Nos. 8304, "Gazelle" and 8305 "Oryx." Two more "04" G.C.

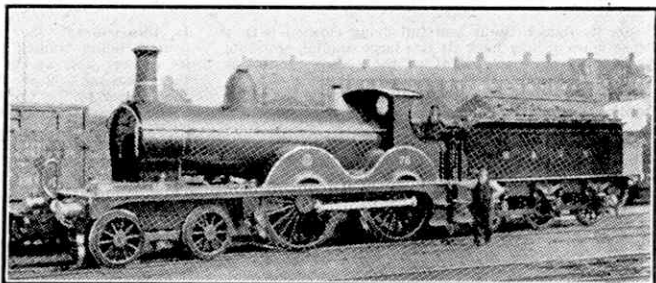

A standard Midland and Great Northern Joint 4-4-0 express engine in its original form.

0-8-0 mineral engines have been converted to "Q1" 0-8-0 shunting tanks. They are Nos. 5044 and 6077.

Up to the end of 1943, at least 29 of the original 52 "A1" 4-6-2 engines had been reboilered and modernised as "A3" or "super-Pacifics"; two more lately so rebuilt are No. 2549 "Persimmon" and No. 4478 "Hermite." We recently learned that nine "A1" class "Pacifics" were stationed at Doncaster shed, also many "Green Arrows," but owing to a re-allocation of streamlined "A4s" the three of that type hitherto remaining at Doncaster had moved to Grantham.

Only three "C2" class Ivatt small "Atlantics" remain in service; they are Nos. 3250, 3252 and 3256, all shedded at Lincoln or Retford. Scrappings of standard large 4-4-2 express engines include No. 5366 of the 2-cyl. G. C. Robinson design class "C4," introduced about 40 years ago, and No. 2202 of the former N.E.R. 3-cyl. more modern "C7" class. More of the Ivatt Great Northern type "N1" 0-6-2T suburban locomotives have gone from King's Cross to Bradford, including some of the superheated ones; in exchange "N7" tank engines of the L.N.E.R. series built by Beardmore and Co. Ltd. in 1927, based on the Great Eastern 4 ft. 10 in. "1000" class, have returned from Bradford to Hatfield duties in the King's Cross district. Most of the engines in this numerous class work London suburban services on the Great Eastern section.

"Austerity" British W.D. 2-8-0 engines have been working freight and also some passenger trains on the difficult West Highland route between Glasgow, Fort William and Mallaig. They also appear on many other parts of the system, as do their American sisters, particularly where there is heavy mineral traffic.

To the South Coast "Via Quarry"

Readers may have noticed in lists of S.R. main line electric train route indications "Brighton" (or some other Sussex coast destination) "via Quarry," as distinct from "via Redhill," and may have wondered what the former actually implies.

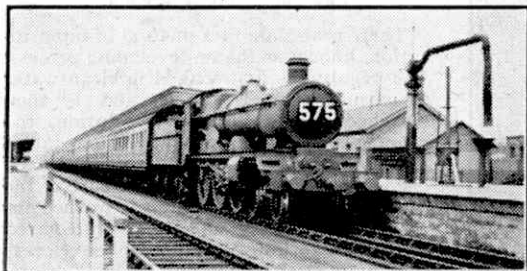

G.W.R. "Star" 4-6-0 No. 4031 "Queen Mary" on a summer Ilfracombe-Manchester express.

Years ago, trains of the South Eastern, afterwards South Eastern and Chatham, and the London, Brighton and South Coast Railways intermingled a good deal between London Bridge and Redhill Junction. In order to reach their own metals on the Coulsdon-Redhill-Reading line, the South Eastern used L.B. and S.C. tracks between London Bridge and Coulsdon. Thence to Redhill through Merstham tunnel and station, however, Brighton trains ran over S.E. lines. To relieve congestion and obtain independence, the Brighton Company opened its own line in 1900 from Coulsdon North, 15 miles from London, to Earlswood, which became the fast down and up tracks used by all expresses from London Bridge or Victoria to the Sussex coast. This cut-off is 6½ miles long and is without an intermediate station. It traverses the chalky region of the North Downs and on it are situated Quarry tunnel and Quarry signal-box, hence the name.

The tunnel is also known as Merstham New Tunnel, nearly 1½ miles long, as distinct from the old Merstham tunnel on the Redhill route, which bores through the same downlands at a lower level. A curious feature of the Quarry line is that it crosses the old S.E. route by an overbridge near Star Lane Box, transferring from the west side to the east. Another unusual feature is that near Coulsdon it passes through a covered way that appears to passengers to be a short tunnel, but has nothing over it except iron sheeting, etc. This was constructed at the request of the management of a large Mental Hospital in the vicinity.

Since 1933 S.R. electric passenger services have been worked by both Quarry and Redhill routes between London and the Coast. Steam freight, parcels and other trains are operated both ways. There are four lines all the way from the London terminus as far as Three Bridges, 29½ miles out, and as already indicated, the up and down Quarry lines constitute the fast tracks, and the Redhill lines the slow ones, between Coulsdon and Earlswood. Important cross-country steam services operate from

Redhill, eastward to Tonbridge and the main Kent lines, and westward to Guildford, connecting to the Western section, S.R., and Reading for the G.W.R.

More Impressive Traffic Figures

By December 30th last, the L.M.S. had run 100,000 wartime special trains on Government account. This total included 52,603 troop and personnel trains, and 47,000 conveying stores, petrol, ammunition and other materials, requiring nearly 1½ million wagons and other freight vehicles of all kinds. The total mileage run by all these special trains was nearly 11 million!

Over 25 million more passengers were booked in 1943 than in 1942, and yet it has been possible to provide very little new rolling stock and large proportions of coaching vehicles have to be earmarked continuously for Services' and workpeople's journeys. On the G.W.R. 19,000 troop and personnel specials were run last year, involving unprecedented demands upon the locomotive and operating staffs. To meet the Services' requirements of armaments and supplies 490,000 wagons had to be pressed into service. Much of the freight rolling stock is "common-user," and is employed to the best advantage by any of the companies, as directed by the Controllers.

Church Services in a Waiting Room

As their nearest Parish Church is 3½ miles away, villagers at Troutbeck, in the Lake District of Cumberland, attend services held in the waiting room at the L.M.S. station, the vicar cycling over each Sunday in order to officiate.

Many More Goods Guards

The great increase in freight traffic on British railways has necessitated the appointment, among other additional operating staff, of some thousands more goods guards for wartime service. They are mainly obtained by withdrawing suitable men from other grades for training in train working, and replacing them by women or other temporary staff. Guards of freight trains may under present conditions have to work long and uncertain hours; frequently they are relieved *en route* at stations or yards far from their homes and the Control Offices arrange their

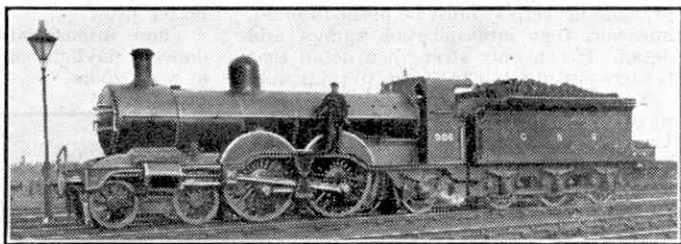

An L.N.E.R. "Atlantic" of class "C2" in its former G.N. colours and lettering, but rebuilt with superheater and extended smoke-box. The engine was scrapped in 1937. Photograph by W. H. Whitworth.

return workings or perhaps order them to travel home by passenger train if excessive working hours would thus be avoided.

Fluorescent Lighting Extended

Fluorescent lighting is being extended by the L.N.E.R. to further booking and enquiry offices at principal stations. This system is said to give the nearest approach to daylight obtainable by artificial means; it is also fireless, so that its use will probably become much more general after the war. Special mercury vapour lamps are employed.

Photography

Improving Thin Negatives

By John J. Curtis, A.R.P.S.

There is also another method of intensification, known as the re-developing process. The negative is first soaked in clean water to ensure regular action, and is then bleached in the Chromium solution, the chemicals for which are supplied in tablet form. The solution bleaches all the black (silver) deposits, and when this part of the process is complete, the film is washed for about 10 minutes and then transferred to a clean working Metol-Quinol developer, such as is used for making gaslight prints. In this the original black image quickly reappears. Do not hurry to take it out, but leave it in the bath for a further five minutes. Then wash and dry it in the usual way. Here again the process can be repeated until considerable density is added to the image.

It is not always easy to decide whether the trouble is due to under-exposure or to under-development, for there is a great similarity, and both give flat prints with little contrast. All negatives that are too thin to print well should therefore be experimented with before being discarded: and the chances are that many will be saved and prove worth keeping. Even if the image is only slightly improved you will find almost for certain that on a glossy gaslight paper you will get a much better print.

These intensification operations can be done in daylight or in the ordinary light of your room.



Portrait of a Nurse. Photograph by M. W. Taylor, Southall.

WHILE it is a common experience to make mistakes when exposing and to produce negatives that fail to yield good prints, it is unwise to destroy these negatives without trying to improve them. For instance, a very thin negative, due to slight under-exposure or to under-development, will often respond very effectively to one of the intensification processes by means of which the image is strengthened or made denser. It must be borne in mind, however, that intensification cannot add detail. It can only strengthen detail that is there already, but too weak to print well.

Try some of your thin negatives with Johnson's Uranium Intensifier. The method is quite simple. Just soak the film thoroughly in clean cold water for about 30 minutes, then place it in the solution. It quickly absorbs colour until it becomes a deep bronze or orange tint. Then rinse it in still water to remove the solution from the surface, but do not wash it until the colour is removed. When the film is dry the image will show in a more defined manner and the resulting print will have greater contrasts. If the effect is not sufficient the process can be repeated.



"The Yorkshire Dales." Photograph by J. Mitchell, Bradford.

From Our Readers

This page is reserved for articles from our readers. Contributions not exceeding 500 words in length are invited on any subject of which the writer has special knowledge or experience. These should be written neatly on one side of the paper only, and should be accompanied if possible by original photographs for use as illustrations. Articles published will be paid for. Statements in articles submitted are accepted as being sent in good faith, but the Editor takes no responsibility for their accuracy.

THE RAILWAY IN MONSAL DALE

Since its construction about the year 1865 the large railway viaduct in Monsal Dale, Derbyshire, has come in for much criticism, both favourable and otherwise. A fierce outburst against what he thought the spoiling of this particular valley was made by Ruskin, who wrote: "There was a rocky valley between Buxton and Bakewell . . . You enterprising a railway through it . . . and now every fool in Buxton can be in Bakewell in half an hour and every fool in Bakewell at Buxton."

Time has softened the scars, and the viaduct is considered by some people as not detracting from the charm of Monsal Dale. The line passes through a tunnel before crossing the viaduct, and in his "*Highways and Byways of Derbyshire*" J. B. Firth describes how he waited for a train to emerge. "A little while and a rumbling began, growing in intensity every second until, with an exultant roar, the express came out from the hill below me, crossed the bridge, and swung round the bend of the embankment towards Monsal Dale station. The engine was straining up the incline, working hard, putting forth obvious effort, and addressing itself to its task. In a few moments another train came gliding down in the opposite direction, not conscious of her load. She flew down the embankment like a skater with the wind behind him, holding her breath in

enjoyment of the pace." How different from Ruskin's scathing words!

In the accompanying photograph three engines can be seen on their way down to Rowsley, where they supplement engines drawing a heavy load up this steep gradient. The line from Rowsley through

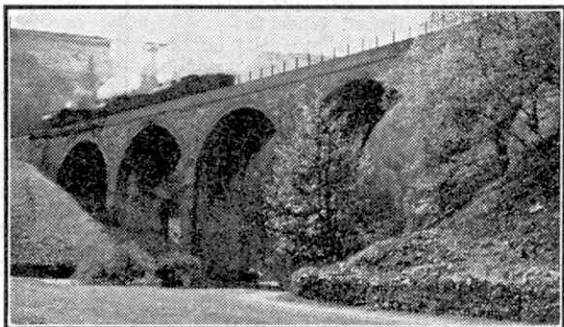

A railway viaduct in a Derbyshire dale. Photograph by F. Rodgers, Derby.

Monsal Dale, Millers Dale, and Chee Dale is a marvel of engineering, and passes through some of the finest scenery in England. FRANK RODGERS (Derby).

AN OUTING ON FATHER THAMES

A trip on Father Thames in times of peace provided many thrills and pleasantries, not the least being the meeting of new friends combined with the possibility of encountering life-time acquaintances. Locks alongside the Thames make ideal meeting places for students, clubs and any other kind of fellowship gathering in search of an outing upon which they can look back with a pleasant memory.

Londoners in general are more or less familiar with the lock-trips made in well appointed pleasure boats, but for one living so far away as the Southampton area of Hampshire such a trip was an entirely new and delightful experience. A lovely day is to be chosen for such an outing and the use of a camera to obtain a snap or two will further serve to stamp the day's happy impressions indelibly on the mind. The accompanying illustration of Teddington Lock is a fine example of the photographs that can be taken and helps also to show how delightful the trip can be.

C. TURNER (Brockenhurst).

A BERKSHIRE BLOWING STONE

Near Wantage in Berkshire, not far from the White Horse Hill, there is a stone known to the local people as "The Blowing Stone." This is believed to date back to before the year 900, but the date of origin has never been fixed. The stone is about 3 ft. high and 1 ft. wide. On it is quite a number of small holes, with one considerably larger than the others, and blowing down one of the small holes with the action of a bugler produces a note that is very penetrating and has been heard often more than seven miles away. It is said that in the far off days of King Alfred this stone was used to call men to Wantage, where they rallied ready to attack any foes of the Realm.

R. G. CATTERMOLLE (Taunton).

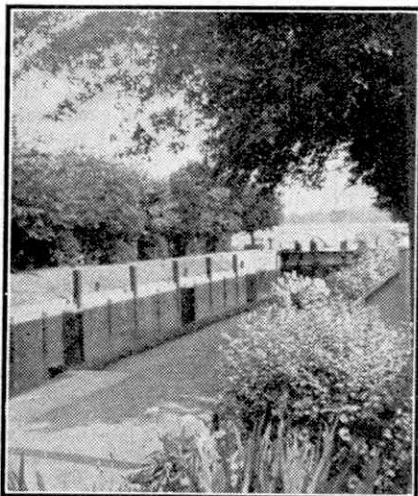

Teddington Lock, on the Thames. Photograph by G. C. Turner Brockenhurst.

Suggestions Section

By "Spanner"

(636) Clutch Mechanism for Small Model Cars (G. Clark, Leeds)

A small and reliable clutch mechanism that can be incorporated in most types of small model cars, is shown in Fig. 636 on this page. It consists of two members; the driving member for a $\frac{1}{2}$ " Pulley 1 fitted with a Dinky Toys Racing Car Tyre, and the withdrawal member a $\frac{3}{4}$ " Flanged Wheel 2.

The $\frac{1}{2}$ " Pulley 1 is mounted on one end of the driving rod, and normally is held in contact with the Flanged Wheel 2 by means of a Compression Spring that is placed on the driven shaft between the Flanged Wheel 2 and a Collar 3 that is secured to the Rod. The Flanged Wheel is mounted loosely on the Rod, but is caused to rotate with it by two Flat Brackets that are bolted to it and lock-nutted by their elongated holes to the Collar 3.

A suitable clutch withdrawal mechanism should consist of two arms resting lightly on the flange of the Flanged Wheel 2 so that when the clutch pedal is depressed, the arms engage the rim of the Flanged Wheel and force it away from the $\frac{1}{2}$ " Pulley 1 and the Motor Tyre.

(637) A Novel Three-Point Cam (R. Roberts, Glasgow)

Many applications for cams arise in Meccano model-building, for very often a simple cam can be used to bring about movements that otherwise would require complicated mechanisms. There are, of course, many different forms and types of cams, some of which are suitable only for specified purposes. A simple cam that gives three operational points for every revolution of the shaft on which it is mounted is suggested by R. Roberts, Glasgow, and his method of construction is shown in Fig. 637. This cam consists of a Triangular Plate, which is bolted securely to a Face Plate, so that the corners of the Triangular Plate project over the rim of the Face Plate.

In bolting the parts together care must be taken to ensure that the Triangular Plate is correctly centred on the Face Plate.

The applications of a cam built in this manner are of course limited, but it would be useful in timing mechanisms and in operating work-table feed mechanisms in certain kinds of machine tools.

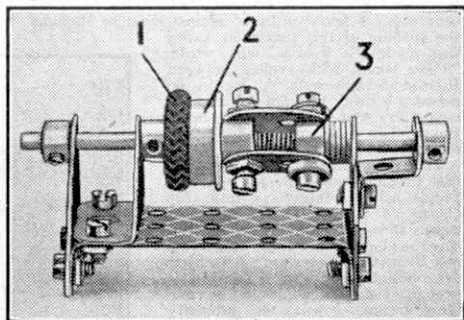

Fig. 636.

(638) Geared Quick Return Motion (“Spanner”)

Quick return mechanisms are used extensively in planning machines for speeding up operations by increasing the speed of the return or idle stroke of the cutting tool. They can be employed also for intermittent feed movements in which a moving Pawl is used for rotating a Ratchet Wheel. In this case the arm carrying the Pawl would be speeded up on the return stroke so that the pause between each movement of the Ratchet would be decreased.

Many different types of quick-return motion can be reproduced in Meccano, and a particularly interesting example appears in Fig. 638 on the next page. This mechanism incorporates a gear movement and gives a very smooth and powerful drive.

A Face Plate is secured to a Rod 1 that is journaled in vertical $5\frac{1}{2}$ " x $2\frac{1}{2}$ " Flanged

Plates, and an Eye Piece 2 is attached to the Face Plate by passing a $\frac{3}{8}$ " Bolt through one of the holes in the latter and fixing the Bolt in the boss of the Eye Piece by the Grub Screws. Two Washers are placed on the shank of the Bolt for spacing purposes.

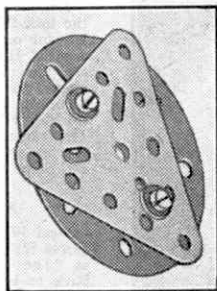

Fig. 637

A $5\frac{1}{2}$ " Strip is mounted pivotally on a $\frac{3}{8}$ " Bolt 3 that is lock-nutted to a Double Bent Strip. The Eye Piece slides on the longer arm of the lever so formed, and the short arm carries a Rack Segment 4 that engages with a 1" Gear 5. The latter is fixed on a Rod journalled in the Flanged Plates and connected by any suitable means to the model it is intended to operate.

When the device is set in motion, the Rack Segment on the end of the $5\frac{1}{2}$ " Strip moves from side to side at a speed which varies according to the distance of the Eye Piece from the fulcrum 3 of the Strip, and this causes the 1" Gear to rotate slowly in one direction and rapidly on reversing.

(639) Solenoids for Magnetic Mechanisms ("Spanner")

Several "M.M." readers have written to me recently for advice on the winding of solenoids suitable for use with various types of magnetically operated mechanisms. For most purposes a Meccano Bobbin wound with 26 gauge S.C.C. copper wire will be found suitable. The end of the wire should first be passed through one of the holes in the fibre end of the Bobbin, and the latter should then be wound to its full capacity. When winding is completed the wire should be cut from the spool and its free end passed through the second hole in the fibre end piece of the Bobbin. Finally a strip of stiff paper should be wound round the Bobbin and secured in place by a touch of glue. A solenoid of this type can be used with a current supply at voltages of from 2 to 6. It will heat up if used with higher voltages, and the insulation of the winding will be destroyed.

It is permissible to connect two or more such solenoids to an accumulator or 6-volt Transformer, provided that they are placed in series with each other in order to give as high a resistance as possible. A single solenoid of the type described should never be connected directly to an accumulator or Transformer, as too large a current will flow. If only one solenoid is required a Meccano 6-volt Resistance Controller should be connected in series with it.

Nearly 20 Years of "Suggestions Section"

In November next year "Suggestions Section" will be 20 years of age, for it first appeared in the November 1925 issue

of the Magazine. Since that time it has always been "Spanner's" aim to describe each month on these pages ideas and mechanisms that may be incorporated with advantage in many different types of models. Sometimes these suggestions have dealt with particularly novel uses for Meccano parts.

We know from letters received from readers living in all parts of the world that these suggestions prove helpful to model-builders, and we think readers will agree that they provide striking demonstrations of the versatility of the Meccano system and the ingenuity of Meccano boys.

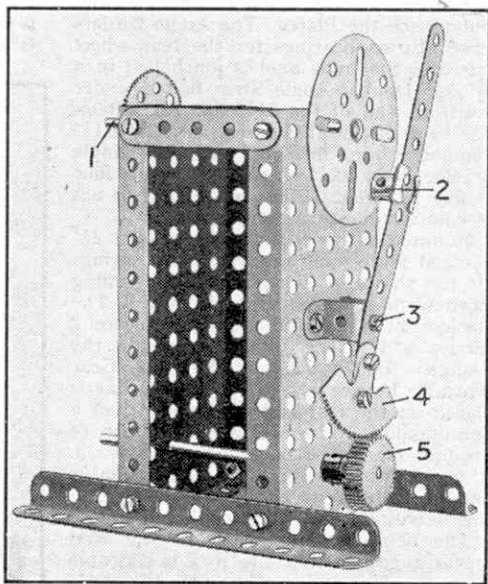

Fig. 638

These pages have been compiled by "Spanner" since the start of "Suggestions Section" in 1925. He has been greatly helped in his task of maintaining the interest of the section by hundreds of contributions sent in by model-builders themselves. Unfortunately the war has brought many difficulties, and many of "Spanner's" regular contributors have been compelled to suspend their Meccano activities temporarily to play their parts as members of His Majesty's Forces. "Spanner" wishes to thank all of these old friends for their great help in the past, and he hopes that in the happier days to come, when Victory has been won, they will again contribute to these pages.

New Meccano Models

Mobile Crane—Truck

THE two new models described this month are a fine mobile crane capable of lifting heavy loads, which is illustrated in Fig. 1, and a simple truck shown in Fig. 2.

In building the fine mobile crane shown in Fig. 1 it is best to commence construction with the chassis. This consists of a $5\frac{1}{2}'' \times 3\frac{1}{2}''$ Flat Plate extended at the rear end by a $2\frac{1}{2}'' \times 2\frac{1}{2}''$ Flat Plate, which is supported by six $3''$ Angle Girders 1 bolted underneath the Plates. The Angle Girders serve also as bearings for the rear wheel axle and the front axle is journalled in a $3\frac{1}{2}'' \times \frac{1}{2}''$ Double Angle Strip bolted under the front end of the $5\frac{1}{2}'' \times 3\frac{1}{2}''$ Flat Plate. The back of the driver's cab is a $2\frac{1}{2}'' \times 1\frac{1}{2}''$ Flanged Plate, held in place by Angle Brackets and to the rear face of this four or five $2\frac{1}{2}''$ Flat Girders are bolted to act as counterbalance weights.

Mounted on the chassis are two $2\frac{1}{2}'' \times 2\frac{1}{2}''$ Flanged Plates, and these provide bearings for the shafts of the hoisting and luffing mechanism, and also support the jib. The mechanism is arranged as follows: A Rod 2 carries a $1''$ Gear Wheel 3 outside the Flanged Plates and a 50-teeth Gear centrally between the Plates. A Collar is placed on the rear end of the Rod and a Compression Spring between the face of the first Flanged Plate and the $1''$ Gear 3. A Crank fitted with a Threaded Pin is fixed on the front end of the Rod, and this serves as the operating handle.

The components carried on the Rod are arranged so that the Rod is slideable in its bearings and can be pushed inwards against the Compression Spring. When the Rod is held in its normal position under the influence of the Spring, the $1''$ Gear 3 meshes with a second $1''$ Gear 4 on Rod 5, but when it is pushed inward the 50-teeth Gear is brought into mesh with a $\frac{3}{4}'' \times \frac{1}{2}''$ Pinion 6 held on a $2\frac{1}{2}''$ Rod journalled in Trunnions. This Rod forms the winding drum for the Cord 7 that controls the luffing of the jib. The Rod 5 forms the winding drum for the hoisting and lowering Cord 8, and is held in place in the Flanged Plates by means of Collars. When the operating shaft 2 is in its normal position therefore the load hoisting gears are engaged, but they are disengaged, and the luffing gears engaged, when the Rod 2 is pushed inward.

A simple but powerful brake is provided to retain the jib at the required angle when the luffing mechanism is disengaged and hoisting or lowering of the load is being carried out. This brake consists of a $2\frac{1}{2}''$ Driving Band wrapped twice around a Coupling—on the rear end of the $2\frac{1}{2}''$ Rod and looped through a hole in one arm of a Boss Ball Crank 10, which is pivoted on a $\frac{3}{4}''$ Bolt locked in the rear Flanged Plate. The other arm of the Ball Crank is weighted by means of a $1''$ Gear which is shown.

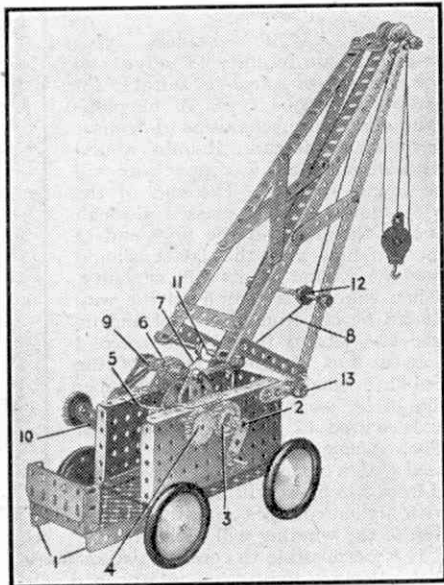

Fig. 1. This fine working model mobile crane is easily built and is capable of lifting heavy loads.

The luffing and hoisting cords are attached to their winding Rods by means of Anchoring Springs, Part No. 176. The other end of the luffing Cord is attached to a $\frac{1}{2}''$ Pulley 11 on a Rod fixed in the jib, as shown.

The construction details of the jib are simple and can be followed from the illustration. The hoisting Cord passes under the Pulley 12 which is fixed on a Rod mounted freely in the $12\frac{1}{2}''$ Strips forming the underside members of the jib,

and then is led over the pulley at the jib head, and around the Pulley of the single sheave Pulley Block. From the Pulley Block the Cord is taken back to the jib-head Pulley and finally is tied to the lug of the Pulley Block.

The jib is pivotally mounted on a 4" Rod 13 journalled in Cranks bolted to the 5½" × 2½" Flanged Plates.

The crane travels on four Road Wheels.

Parts required to build model Mobile Crane: 2 of No. 2a; 3 of No. 3; 1 of No. 4; 3 of No. 6a; 2 of No. 9c; 3 of No. 15a; 3 of No. 16; 1 of No. 16a; 9 of No. 17; 2 of No. 20; 2 of No. 23a; 1 of No. 25a; 1 of No. 27; 13 of No. 31; 42 of No. 37a; 42 of No. 37b; 2 of No. 48b; 1 of No. 51; 3 of No. 52; 1 of No. 52a; 14 of No. 59; 2 of No. 62; 1 of No. 63; 2 of No. 72; 3 of No. 103f; 2 of No. 111; 2 of No. 126; 1 of No. 128; 1 of No. 151; 2 of No. 176; 1 of No. 186; 4 of No. 187.

The truck, shown in Fig. 2, consists of a 5½" × 2½" Flanged Plate 1 to which two 4½" Strips are bolted to form the Shafts. At their outer ends the two Strips are joined by a 3" Rod held in place by Collars as shown. The Wheels are mounted on a 3½" Rod journalled in Flat Trunnions, and they are 3" Pulleys shod with Rubber Rings. The truck is supported by legs 2, consisting of 3" Strips bolted to the Flanged Plate 1 and

made rigid by means of Corner Brackets. At the rear end of the Flanged Plate is bolted a 2½" × 2½" Flexible Plate and the upper edge of this is attached to 5½" Strips 3, the other ends of which are attached to Flat Brackets bolted to the Flanged Plate. Two 2½" Strips 4 brace the 5½" Strips and serve also to form parts of sides of the truck.

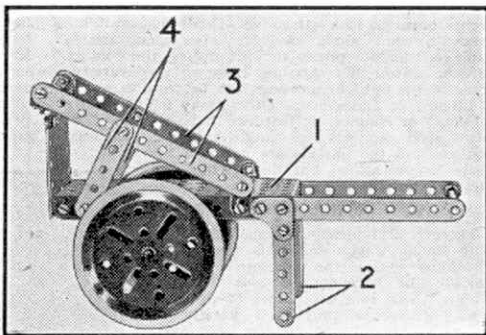

Fig. 2. A simple luggage truck.

Parts required to build model Truck: 4 of Part No. 2; 2 of No. 4; 3 of No. 5; 2 of No. 10; 2 of No. 12; 1 of No. 16; 1 of No. 16b; 2 of No. 19b; 24 of No. 37a; 24 of No. 37b; 1 of No. 52; 2 of No. 59; 2 of No. 126a; 2 of No. 133a; 2 of No. 142; 1 of No. 190.

New Year Model-Building Contest

By "Spanner"

The closing date in this great contest is 31st March. Model-builders, including beginners as well as those with long experience, no doubt will now have completed their models and are ready for sending in the required details. There is still plenty of time for those who have not done so, and we give again the details of the contest, which show how attractive it is. There are two sections in it, one for model-builders in general of 14 years of age or more, and the other for younger readers under 14, so that all will have a splendid chance of winning one of the many handsome cash prizes that are offered. No model-builder should fail to send in an entry, for in addition to the principal awards there will be consolation prizes and Certificates of Merit for other praiseworthy efforts.

There is no restriction whatever on the subjects of models for entry in this competition. Those who favour motor cars, lorries, and other vehicles can send in details of models of this kind they have constructed. Cranes, excavators, earth-moving machinery and machines and mechanisms of all kinds are eligible, and reproductions of buildings, ships, aeroplanes and similar subjects also form suitable entries. In fact a model of anything that the model-builder has seen and is attracted by can be submitted. The judges will not be impressed by size or intricacy, but will look for ingenuity in design and in the use of Meccano Parts, and faithfulness in reproducing structures and mechanisms.

Models themselves must not be forwarded. All that is required is a photograph or drawing, and if necessary more than one of these, showing different

views, should be submitted. Any notes required to explain constructional and other features may be added. Each competitor must write his name, address and age on each sheet of his entry, which should be forwarded to "1944 New Year Model-Building Contest, Meccano Limited, Binns Road, Liverpool 13."

As already explained there are two sections, A for competitors of 14 years of age or over, and B for those under 14. In each section the prizes will be as follows: First Prize, Cheque for £2/2/-; Second Prize, Cheque for £1/1/-; Third Prize, P.O. for 10/6. In each further Consolation Prizes of 5/- each will be awarded and there will be Certificates of Merit for other good efforts. Closing date: 31st March.

Christmas Holiday Contest Results

In this competition readers were asked to submit humorous stories, of not more than 50 words, written round the names of Meccano Parts or terms used in model-building. Many very fine entries were received, and it is clear that the idea of the contest made a very strong appeal. Pawl figures very prominently in many of these efforts, but Archie Trave made a very promising first appearance as an office boy in several of the stories submitted, and it looks as if he will be an inspiring rival to our old friend Pawl.

1st Prize, Cheque for £2/2/-: W. Whitaker, Dewsbury; 2nd, Cheque for £1/1/-: H. C. Burford, London; 3rd, Postal Order for 10/6: C. Page Royston, Herts. Postal Orders for 5/-: T. D. Tasker, Barnsley, and Sheila McEvoy, Manchester.



Club and Branch News



WITH THE SECRETARY

PLAN NOW FOR THE OUTDOOR SEASON

The evenings are now becoming longer and outdoor events begin to look attractive. Don't just wait for these to come along anyhow. Plan them ahead, fixing on definite places to visit during the coming outdoor season and choosing these to give variety. Some of the outdoor meetings can be trips to places of interest or amusement. Others may include visits to works or engineering features that seem likely to form good subjects for model-building. Railway stations and the lineside are splendid for visits in peacetime, but during the war they are best avoided.

NEW CLUB ROOM PURSUITS

There is still plenty of opportunity for Club room work, and this should be continued during the Summer so as to provide for unfavourable weather conditions. Now is a good time to think of new pursuits to provide a variety of interests. Special sections can be formed for such pursuits as aeroplane model-building, or fretwork, and it will be found that in most cases the work of these sections fits neatly into the general schemes of the Club.

It is surprising too how often a special section can contribute to the efficient running of a Club. An excellent example of this is the Printing Section of the Plymouth M.C., which is run to provide an ordinary Club hobby, and yet produces Club literature, and in pre-war days also printed and published the Club Magazine. It is easy to find if members have any special interest that would justify the formation of a special section, and where this interest exists it is usually equally easy to find a Senior member who can take care as Section Leader.

RECENTLY INCORPORATED BRANCHES

452. CANFORD MAGNA—R. M. Jelfs, 1, Froadway Court, Broadstone.
 454. SHEFFIELD—R. Goff, 164, Valley Road, Meersbrook, Sheffield.
 455. DUKINFIELD—L. D. Broadbent, 395, Cheetham Hill Road, Dukinfield.
 456. HILLSBOROUGH—F. Skelton, Jnr., 12, Bickerton Road, Hillsborough, Sheffield 6.
 457. MORDEN—P. C. Haines, 86, Camborne Road, Morden, Surrey.

PROPOSED BRANCHES

- NEWPORT—Mr. R. Edmunds, 31, Fairlee Road, Newport, Isle-of-Wight.
 SOUTH SHIELDS—Mr. J. Colvin, 42, King George Road, South Shields.
 LEEK—Mr. J. White, "Dulce Domum," Huge Street, Leek.
 ALDERSHOT—Mr. L. Alldridge, 38, Guildford Road, Aldershot.

PROPOSED CLUBS

- OXFORD—Mr. G. Barber, 8, Northmoor Road, Oxford.
 RATHFARNHAM—Mr. N. Shannon, "Sallowglen," 16, Rathfarnham Park, Rathfarnham, Dublin.
 MORLEY—Mr. J. V. Chambers, 28, Watson Street, Morley, Leeds.

CLUB NOTES

GRASMERE M.C.—The usual programme of competitions has been followed. In one model motor cars were built, and others included a Quiz and a Spelling Bee, small prizes being awarded out of Club funds. Parents were invited to the Annual Meeting, when Merit Medallions were presented. On this occasion each member displayed what he thought the best model he had made during the year. Refreshments were provided and a collection was made on behalf of British Red Cross funds. The Library has been greatly enlarged. Club roll: 21. *Secretary:* I. H. Hard-

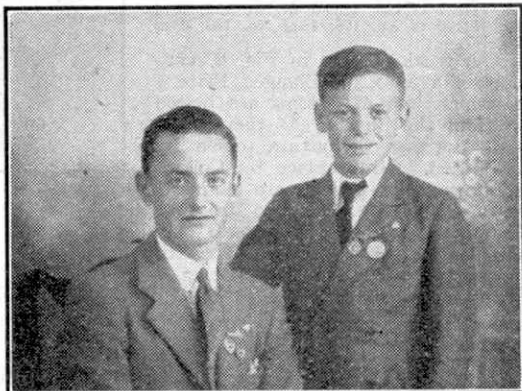

The Exeter M.C., Leader, Mr. M. C. Hodder, is well represented in the Government of the Exeter Parliament of Youth. R. Godfrey, on the left in our photograph, captain of one of the Club's football teams, is Chancellor of the Exchequer; I. L. Coates, on the right, Secretary of the Club, also is a member of the Cabinet. The Exeter Parliament of Youth is representative of all boys' movements and interests in the city.

man, "Greenburn," Wansfell Road, Ambleside, E. Lakes.

KILROOT M.C.—Model-building and Woodwork have been the leading features. The models built included aeroplanes, cranes, motor vehicles and a tank. The Woodwork Section has made letter racks and calendars, some of which were sold at Christmas. Observation and General Knowledge Tests, a Stamp Treasure Hunt, Darts, etc., have added to the fun. Club roll: 14. *Secretary:* J. C. Mulvagh, Dobb's Cottage, Kilroot, Co. Antrim, N. Ireland.

ISLINGTON M.C.—The Club has been bombed out of four Club rooms, but new quarters have been offered and meetings are again being held. All who are interested are invited to get in touch with the *Leader:* Mr. V. Miller, 541, Liverpool Road, London N.7.

LONG ITCHINGTON M.C.—Signals and a large crane have been made in Meccano for the layout of the associated Branch. One room has been converted into an office. The Library has been enlarged and a Magazine is being produced. Club roll: 8. *Secretary:* J. Gaskin, 3, Model Village, Long Itchington, Nr. Rugby.

GRASMERE M.C.—Competitions in building aeroplane models and gear-boxes have been held. Members are hard at work building new models and making experiments in chemistry. Club roll: 30. *Secretary:* I. Hardman, "Greenburn," Wansfell Road Ambleside.

The "Ennis Valley" Hornby Railway

OUR Gauge J layout this month is of special interest in representing a system jointly worked by Hornby G.W.R. and L.M.S. Locomotives and Rolling Stock. At one period of its development it was actually jointly owned and worked by several model railwaymen, but the system as it now stands belongs to our

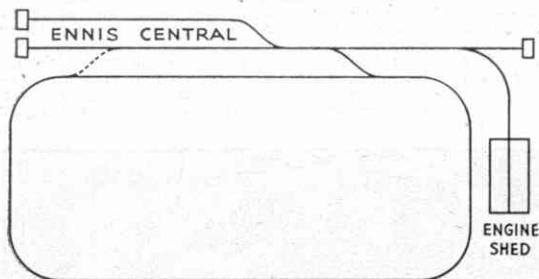

Diagram of the layout of E. G. Libby, Penzance, described on this page.

reader E. G. Libby, of Penzance.

This railway began quite a long time ago with the purchase of a simple Hornby Train Set. In the early days progress was slow, but later an electric line joined forces with the original clockwork one and a "Company" was formed to run the system. More recently the line has reverted to single ownership, and in its present form is admirably suited to the control of one operator.

So much for the history of the "Ennis Valley Railway" as it is called. It is supposed to serve an imaginary part of Wales, where there are valuable mineral deposits. This situation of course permits the use of L.M.S. equipment in addition to G.W.R. Rather wider scope in working is thus afforded than if a local system based on the owner's own district had been chosen.

The actual layout of the track will be clear from the diagram reproduced on this page. "Ennis Central" is the headquarters of the line and the main part of the working is naturally concentrated there. Two parallel tracks, which ultimately merge into one, serve the station, and this is connected, as shown in the upper part of the diagram, to a continuous oval main line. One of these two tracks is also prolonged to form a fairly long spur and from this a short engine shed branch is thrown off. The railway is electrically operated, and to secure independent control the station and attendant tracks are divided into a number of separate electrical sections. This of course prevents all the electrically-driven engines, which are six in number, from trying to move at once, and it helps considerably in the working of the line.

At present there is only a single connection between the station lines and the main oval. As with most layouts, however, projected improvements are in mind, and it is hoped to lay in the additional crossover points indicated by a dotted line in the diagram.

This will considerably improve the traffic working. At the moment, trains that have left the dead end station lines for the main track have to be reversed to re-enter the station premises. The additional crossover will convert the platform track that is nearer to the main oval into a loop line, so that trains crossing off the main line in a clockwise direction can be worked in without any special movements being necessary.

In addition, as the platform line referred to becomes virtually a passing loop, "up" and "down" traffic can be operated, one train waiting in the loop in the accepted manner while the other makes its way round the single line section forming the main oval. This is always an interesting process in miniature as in actual practice, and working arrangements have to be framed so that the "crossing" of various trains at the loop is allowed for. The lower illustration on this page shows a typical "meet" or "crossing" being carried out on a Hornby railway. A train of wagons is held in the loop while a passenger train passes on the adjoining track.

The "Ennis Valley" line is a portable one but it is laid with small scale permanent way, and arrangements are at present being made for the operation of points and signals from a lever frame which is installed in a Hornby Signal Cabin. A novel point in connection with train control is that as a train approaches the buffer stops in the station that particular section is made "dead" for the time being, so that safety first is ensured and buffer stop collisions are unknown. Lineside effects are simple in view of the portable nature of the railway.

The principal train on the line is, suitably enough, known as the "Ennis Flyer." It consists of five Hornby Saloon Coaches and is usually hauled by a "Princess Elizabeth" 4-6-2. Mineral traffic, of which there is plenty, is usually handled by tank engines,

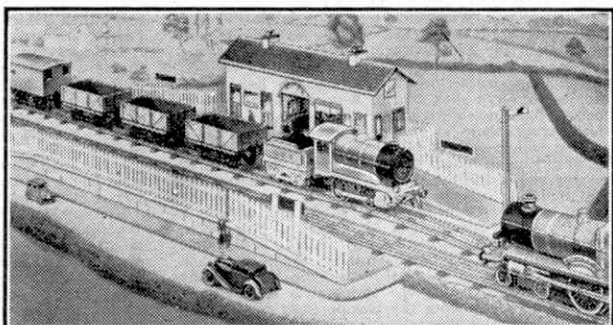

Trains crossing at a passing loop on a Hornby Railway. An express runs through while a goods train waits for it on the loop line.

thus reproducing the characteristic practice of the local railways in South Wales. The engines used are Hornby E120 and EM320 Tanks, there being two of the latter on the line. These also take an important part in suburban train working, and when necessary they share the shunting duties in which another engine, a 0-6-0 saddle tank usually specialises. G.W.R. tender engines are represented by two E220 Specials of the "County of Bedford" type.

A Splendid Dublo Layout

Military Traffic and Lineside Effects

OLDER readers of the "M.M." will no doubt remember the Hornby Railway operated by D. and J. Birkbeck, Newcastle-on-Tyne, which was described and several times illustrated in these pages some years ago. In its later state the system included also a Dublo track running more or less parallel to the main line in the larger gauge. Since that time the Dublo part of the system has expanded and the Gauge 0 layout is no more, the splendid railway shown in the accompanying illustration having taken its place.

The smaller scale of the Dublo equipment has given considerably more scope to the "Engineers" in planning the present layout. Plenty of material is in use, and is laid out effectively so that there is no suggestion of any "crowding in" to incorporate any particular feature. The space available is fairly generous, 7 ft. 6 in. by 4 ft. or so, and the owners are fortunate in having a special table on which the line is accommodated. The layout is not actually permanent but is usually installed for a month at a time when required. This of course is long enough for it to be fixed up in such a way that most of the advantages of a permanent system are secured for the time being.

The space is rectangular and so the main line follows the popular oval shape. Both up and down lines are available, and an interesting feature is that at the city station, shown prominently in the illustration, the centre track forms the connection between the inner and outer main circuits. As these tracks each have their own Controller, insulating gaps are provided in this centre connecting track, and these are so spaced apart that a train can stand on the section between them. When this section is made "dead," or in other words is switched out, the train can remain there alongside the platform without affecting the running of trains on the main tracks.

The inner track throws off a branch line which divides to serve each side of a goods platform and loading bank as shown in the illustration. From the outer track there is also a trailing connection to further sidings, and a set of facing points that lead to the Engine Shed and locomotive sidings that occupy one end of the layout. Most of the accessories and buildings are the standard Dublo items, but the crane seen at the head of the goods platforms is a Hornby one. Although a bit large in proportion, its appearance is not displeasing, while it is of course most useful for loading operations, especially when traffic is heavy. Another Hornby Series detail is the cutting through which the trains pass as the main line swings away from the Engine Shed to the City Station. Hornby Paled Fencing, Trees and Hedging are used effectively and provide lineside detail that is splendidly finished off by the painted background which can be clearly seen in the illustration.

There is a strong military element in the surroundings and in the traffic that is handled on the line, and this is quite appropriate under present conditions. The anti-aircraft gun emplacement near the line will be noted, apart from the pieces of motorised equipment on the roads inside the main oval. Pressure of traffic, and of course convenience in loading, no doubt account for the presence of the troop train that is loading up at the goods platform. The Open

Wagons for guns and vehicles, the Van for stores and the Two Coach Articulated Unit for personnel make up an interesting and effective train for military traffic. "Emergency conditions" are further reflected in the presence near the City Station of a Dinky Toys Motor Van with camouflaged finish, and alongside it a Fire Engine or "red machine" of the latest limousine type.

At the same time normal civilian traffic has not been neglected. There are a Royal Mail Van and Motor Vans providing services connecting with the railway, a Mechanical Horse and Trailer, and one or

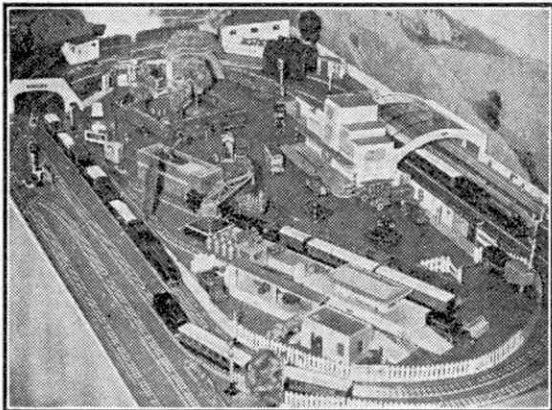

The layout of D. and J. Birkbeck, Newcastle-on-Tyne. Note the troop train being loaded up in the centre.

two other vehicles. Dinky Toys Police and A.A. Patrols are provided to regulate the traffic.

Train services are carried out with a number of the standard Dublo vehicles both for passenger and goods traffic. Both long distance main line and suburban working are practised, and in the illustration there is seen a local train just clearing out of the way ready for the express standing in the station to start off on its journey. Two standard Dublo Tank Locomotives run the local passenger and goods trains, while the main line workings are shared by a couple of the well-known streamliners of the "A4" 4-6-2 class.

Railway traffic is well controlled by the usual Dublo upper-quadrant Signals, while here and there the slightly smaller Dinky Toys Signals are used. At one place at least, near the overbridge in the illustration, there is an interesting combination of a Dublo Junction Signal with a colour-light signal. Several Signal Cabins are in use—one near the city station, one at the point where sidings come off the main track on both sides so that the "boxman" here has a good view of operations, and yet another governing the engine yard.

The actual control arrangements are concentrated at one point, Transformer No. 2, both up and down Controllers being side by side. In addition the "bank" of Switches connected to the Isolating Rails is placed near to hand so that the operator has all controls within easy reach. A point to note is that the wiring connections to the track generally and to the Isolating Rails are carried underneath the table. This gives a neat and "clean" appearance to the trackside that greatly adds to the general effect.

Locomotive Working in Hornby-Dublo

LOCOMOTIVE working, whether in real practice or in miniature, is always a most fascinating subject. This month we hope to show how the arrangement of engine duties on a Dublo line is made easier by the operating conditions of to-day, in spite of the fact that the selection of locomotives available on any Dublo system is at present restricted to two types, streamlined 4-6-2 "Sir Nigel Gresley," and the useful and popular 0-6-2 Tank.

We all know that the 4-6-2 streamliner is the ideal

into the required formation, or in distributing them again after the main line run, the Standard Dublo 0-6-2 Tank is ideal. The lower illustration on this page in fact shows a Dublo Tank engaged on these very duties.

Even the slower and more weighty freight trains can be "Pacific" hauled without being really incorrect. We can of course always arrange special "wartime traffic" requirements in order to account for such things. Similar variety in working is possible with the 0-6-2 Tank; even if we have one or maybe two of these in a finish that is different from "our" line, say the L.N.E.R., we can pretend that these "foreign" engines are on loan to our system, just as there are interchanges of locomotives to-day between the four big groups. Quite a varied appearance will be given to the Engine Shed yard in this way as the upper illustration on this page shows.

There seems to be an impression among

some readers that the Dublo-Tank Locomotive is essentially a goods engine, perhaps because it was included in the Goods Train Set on the introduction of the Dublo system. This is not so, however, as the 0-6-2 tanks on the real railways put in quite a lot of time working passenger trains. The Dublo engine of this wheel arrangement can therefore be considered as a mixed traffic engine, especially for the shorter runs on the line. Modern tank engines do, however, venture on quite long trips at times; in any case we can always arrange for a stop to be made at a convenient point for "train examination," while our Tank engine pops round to the "Loco siding" for "coal and water."

Again we can always work the "engine changing" scheme that has been suggested previously in these articles. The engine comes off the train at an intermediate stop and is run into the shed. It then reappears, apparently as a fresh engine, to take on the train. If we have two engines so much the better, we can then actually change them over.

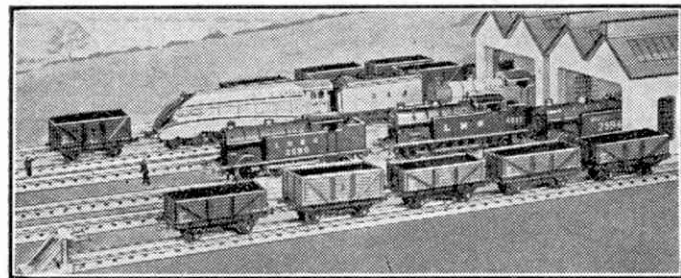

Motive power on a Dublo Railway. Express and Tank Locomotives "on the shed."

engine for our express trains, and the appearance of a Dublo express with this locomotive at its head is very striking and realistic. Frequently, however, we may wish to vary our running programme, or perhaps the working schemes include the operation of secondary or stopping passenger trains. If there is no other engine free at the time, it will be quite in order to use the 4-6-2 for the less spectacular duty. Big express engines, even in peacetime, could often be seen on less important trains. They may thus be used to fill in time in between long-distance trips, or perhaps to work trains to a particular point in order to recommence normal duties from there. We can, therefore, as a regular thing make our streamliner put in a little more mileage after each long-distance turn, in working a purely local train. We shall probably have to use the same coaches as those forming our express train, but that is a regular model railway custom which again is based on real practice.

The regular army of mixed-traffic engines that are so characteristic of modern British practice have as yet no counterpart in the Dublo System owing to the war. The Dublo owner, however, can feel quite happy about using his 4-6-2 on the work that these engines undertake for that is quite a feature of real railway working to-day. We probably have a fast "fitted" goods to run, composed of Hornby-Dublo Vans of various kinds, in every little operating programme or "episode" that we carry out. Our "Sir Nigel Gresley" can do the job most realistically, at least as far as the main line stretch of the run is concerned. For the more local part of the working, such as the picking up the vans and marshalling them

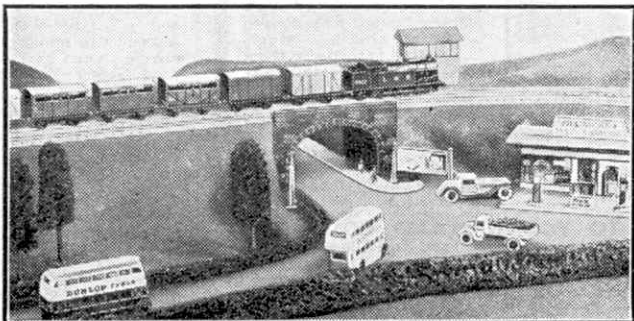

A train of Vans behind a Dublo 0-6-2 Tank. These engines are suitable for a wide variety of duties.

FOR SERIOUS COLLECTORS

Our Bargain "Discount" Approvals contain a fine range of picked Modern and New Issues, Pictorials, Comems., etc., from 1d.—6d. each, less a generous discount (**GENERAL SELECTIONS ONLY. NO SINGLE COUNTRIES OR G.B.**). Approvals or details are post free, and we do NOT send again unless requested. Br. Colonial or Mixed selections available, but no All-Foreign.

Postal Business Only **THE BIRKDALE STAMP CO. (P.T.S.)**
Dept. M, 104, Liverpool Road, Birkdale, Lancs.

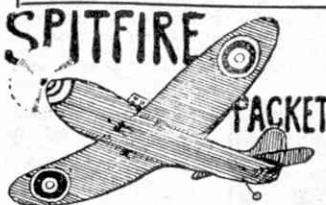

PACKET contains 33 air, triangular, and stamps with aeroplanes, etc.—2 LIBERIA triangular (with aeroplane); NIGERIA; F. OCEANIA; MOZAMBIQUE (Elephants); INDIA; 2 Canada; S. AFRICA (Pictorial); 2 TANGANYIKA; PALESTINE; 4 BRAZIL (aeroplane design, etc.); 5 U.S.A.; ICELAND (Fish); Australia; NEWFOUNDLAND; NEW CALEDONIA; CAMEROONS; ST. PIERRE; MOZAMBIQUE; (Pictorial); MADAGASCAR; THAILAND; CEYLON (Pictorial); EGYPT; BELGIUM (Lion) 60c. Price 5½d., post 2½d. extra. Applicants for approvals receive 6 Pictorial S. Africa and in addition, those sending addresses of stamp collecting friends get set of 4 JAMAICA. **BARGAINS**—100 B. Cols. 2/3; 12 Free French (Cols.) 7d.; 20 Rhodesia 1/6. ASK for LISTS 1d. **H. C. WATKINS (MM)**. Granville Road, BARNET

COUNTRY SETS & PACKETS

25 Bavaria ... 1/6	100 Czechoslovakia 5/-
50 Bulgaria ... 3/6	20 Algeria ... 1/9
15 Cape Verde ... 1/3	50 Luxembourg ... 5/-
50 Denmark ... 2/-	25 Honduras ... 5/6
100 France ... 4/6	10 Porto Rico ... 2/-
25 Finland ... 1/3	25 Estonia ... 2/6
200 Germany ... 3/6	10 Iceland ... 1/3
40 Mozambique Co. ... 3/6	50 France ... 1/6
(Cat. over 22/-) 4/-	10 Mexico ... 9d.
25 Soviet Russia 1/9	25 Turkey ... 1/9
20 Triangulars ... 3/6	25 Ukraine ... 2/6
(Cat. 9/-) ... 3/6	50 Norway ... 2/6
25 Jugo-Slavia ... 1/3	25 Sweden ... 1/-

● Many other interesting offers in our latest list (price 1d.), including special cheap mixture in job lots by weight. We specialise in attractive approval selections of stamps priced from ½d. upwards. Write to-day, and state if approvals required, to:

CAPT. M. CAMPBELL & CO. (Dept. MM)
15, N.W. House, 45, West St., Brighton

DUTCH ROYAL FAMILY PKT. FREE!



This beautiful stamp just issued by CURACAO depicts Queen Wilhelmina of the Netherlands, her Daughter and Husband, and the Royal Children. Three Generations on one stamp. It is included in this excellent packet of all different stamps from British Colonies, unused issues, U.S.A., old French, Australia (K.C.VI), Bohemia, and many others which space does not permit us to mention. Finally a rare Great Britain 100 years old. Just send 3d. postage and request our famous approvals. If new illustrated Catalogue and Price List required, add a further 1d.

Lisburn & Townsend Ltd. (MM), 41, Norton St., Liverpool
Stamp Collections purchased for cash.

TO YOUNG STAMP COLLECTORS

25 different Stamps Free, including St. Vincent, Gambia, Aden, Obsolete Foreign, used and unused. Only to applicants for my famous cheap single and sets of Stamps. Without approvals 9d.

S. H. FLEMING, Newhaven, Glyn Avenue, COLWYN BAY

Write to-day for British Colonial Approvals 1d.—6d. single items, also Coronations and short mint sets. Postage 2½d. Purcell, 22, Green Lane, Amersham, Bucks.

For other Stamp Advertisements see pages 104 and viii.

FREE TO ALL

collectors sending postage (3d.)

This Unique Triangular Health Stamp



G. P. KEEF, WILLINGDON, EASTBOURNE

KING GEORGE VI

A fine packet of unused British Colonials of the present reign from the Cayman Islands, Cyprus, Grenada, Dominica, Malta, Kenya and Uganda, also Southern Rhodesia Jubilee sent free to all applicants for approvals enclosing 2½d. postage.

R. D. HARRISON, ROYDON, WARE

APPROVAL BOOKS

containing low and medium priced Colonial and Foreign stamps still sent to applicants. Good discount and a list of 90 FREE GIFTS varying in value according to money sent for purchases. These gifts can be chosen by you from this list which contains King George VI, Jubilees, Free French, ALL the Coronation Sets Mint, etc. 3d. stamp please.

C. A. RUSH, 38, Queen's Avenue, Whetstone, London N.20

THE GEM STAMP CO.

OF TADWORTH, SURREY (G. E. MOUNT)

regrets to inform their many friends that, owing to the large increase in Wholesale Business, and the impossibility of obtaining further assistance, stamps can no longer be sent on APPROVAL.

If desired, a list of Current Mint Colonials pricing sets to 3d. and to 1/- can be supplied on receipt of 1d. stamp (compulsory charge). These prices are for cash with order, plus postage, and stamps can usually be sent by return of post.

Catalogued 10d., 2/6, 6/—penny each! Approval, 3d. postage please. J. Baguley, 133, Woodstock Avenue, London N.W.11.

Stamp Collecting

Stamps in the Album

By F. Riley, B.Sc.

WE may now suppose the collector to be equipped with an album in which to place the stamps that he has collected, and have seen how these should be mounted. At this point it is well to remind him that he should get a pair of tweezers with which to manipulate his treasures. For those of us who have

"sticky fingers" tweezers are necessities if our stamps are to be kept in prime condition, and they are advisable for all. They are really necessary for lifting stamps floated off envelopes, a task that collectors often have to face.

To attempt to remove a stamp from a dry envelope can only end in the back of the stamp being damaged, or left with bits of envelope attached to it, even if the stamp itself is not torn in two—the most likely result. Instead,

the part of the envelope required should be cut out and floated on cold water in a saucer or shallow dish, with the stamp itself face uppermost. After a time the paper on the envelope will be soaked through and the stamp can then easily be peeled off. Handling a damp stamp may lead to rubbing or tearing, so tweezers should be used. These should be of some non-rusting material, such as brass, and it is worth while practising their use to make the whole process of handling, hinging and mounting one in which the stamp is not touched at all by the fingers.

Another point that should be borne in mind is that the album itself, even if it is designed to stand hard wear, should be dealt with carefully if it is not to become dilapidated. Many stamp albums are supplied in boxes, and in these they should be kept throughout their careers. If no box is supplied a suitable one of cardboard can usually be obtained, and wrappings of good brown paper also are useful for protection. The album is best stored upright, like a book in a bookcase.

It is not always convenient to put stamps in the album as soon as they are received, but they should not be left lying about anywhere while waiting. Small transparent envelopes are plentiful and should be used as containers, not merely kept loose in the pocket, but put in a safe place, say in a book. If they can be obtained; duplicate books are better still; these have pockets into which the stamps are slipped.

With albums providing places for special stamps, arrangement is simply a matter of finding the correct place for each and carefully mounting the stamp in it. To a certain extent this applies also to the simplest form of album, with separate pages for the various countries and squares marked on the pages,

but here there is room for a little care and thought

in order to make a good display. If the suggestions already made in regard to collecting are followed out the enthusiast will be concerned with sets, more or less complete, rather than with individual stamps, and the stamps of these must be arranged in order of price, the lower values first. This may involve leaving one or two blanks, but there should be little difficulty in this.

The albums in which the pages are ruled in fine squares, known as quadrille ruling, and loose-leaved albums, offer more scope to the collector. To begin with, he is able to space out his stamps to suit his own requirements, leaving ample room for headings and details of sets and stamps, or writing-up, as it is called. To this I shall return later in this article. The stamps on each page are usually arranged in rows, and to secure a good effect these should vary in number. The usual plan is to alternate odd and even numbers in successive rows, but the general effect of a page also should be considered. A balance should be maintained about a vertical line through the middle of the page, and also about the central point, which on some pages may be occupied by a stamp. With quadrille ruling the centre of the page is usually marked, and in any case it is only a matter of a few moments to find this by measurement.

The idea is to be well balanced and attractive layout, without overcrowding. A common size for album leaves is 10½ in. by 8½ in., and in general it may be taken that 16 to 18 stamps of average size can be accommodated on a page of these measurements. It is not necessary

to fill every page up to these numbers, however. If in any set of stamps, say of a British Dominion or Colony, there are 10 or 12 different values, designs or colours, then the page should be devoted to the set and the stamps arranged to fill it to the best advantage. For longer sets two pages can be allowed.

Used and unused stamps should be kept separate, and stamps of different sets should not be placed on the same page, unless for some reason the collector

desires to compare or contrast them. An example of an exception to this rule is supplied by the Health Stamps of New Zealand, the latest issue of which was illustrated in the January "M.M." New Zealand has issued Health Stamps over a series of years, and one excellent album page that I have seen shows the issues for the last few years, making up an excellent display that has real value for the

(Continued on page 105)



COUNTRIES MENACED BY "THE YELLOW PERIL"



8 FREE stamps from Australia, New Zealand and India to all applicants for our World Famous Approvals sending 3d. to cover cost of postage.

Dept. 399, **ERRINGTON & MARTIN**
South Hackney, London E.9. Est. 1880

MALAYAN SPACE FILLERS

Postage Extra. Gibbons' SIMPLIFIED Nos. Mint marked *

STRAITS SETTIS: 3d. ea. 135, 141, 142, 167, 183, 184, 187, 198. 4d. ea. *53, 53, 157, 176, 180, D4, D9. 6d. ea. 31, 33, 34, 39, 71, *92, 125, 177, *181, 186, DS, D11. 9d. ea. 13, *119, 185. 1/- ea. *61, *62, *120, 178, 193. 1/6 ea. *44, 194. 2/- ea. 28, *60, 158. 3/6 ea. 195.

JOHORE: 3d. ea. 45, 64, 67, 69. 6d. ea. *5, 52, 70. 1/- ea. *6, *7, 53, 76. 2/6 ea. *29, 54. 6/- ea. 55.

F.M.S.: 2d. ea. 21, 26, 39. 9d. ea. 43, 46. 1/- ea. 47.

S. UJONG: 1/- ea. *13, *14.

SARAWAK: 4d. ea. 90. 6d. ea. 54, 93. 1/- ea. *26.

TRENGGANU: 4d. ea. *1, *20, 25, 27, 29. 9d. ea. 30A, 31, 33.

PERAK: 1d. ea. 38, 39, 40, 41. 2d. ea. 44, 53, 54, 57, 58. 4d. ea. *11, 43, 62. 6d. ea. *12, *13, 47, 60.

9d. ea. *8, 59. 1/6 ea. 50.

Reliant 1944, Br. Empire Catalogues, 6/4 including Postage.

FRED HARLOW, 133, Bradbourne Vale, Sevenoaks, Kent

OUR 1943 PRICE LIST

is now subject to many price revisions.

List of these may be had against 1d. stamp.

(1944 list will NOT be ready for some weeks).

OUR OFFERS ARE STILL THE BEST VALUE IN THE TRADE and include many sets which are to-day quite unobtainable elsewhere.

NORRIS & CO. (Dept. M), SOMERCOTES, DERBY



4 GIFTS IN ONE

(a) 1d. Tonga 1943 Jubilee. (b) Curacao "Happy Event" Commem. (c) F. Poland 1943. (d) 2d. S. Africa War Effort. All the recent issues FREE in one packet! Send 3d. now asking for a Globe-Trotter Approval Book and Leaflet.

GLOBE-TROTTER

70, West Ave., Birmingham 20

SWASTIKA STAMP PACKET FREE



We have been extremely fortunate in obtaining a supply of GERMAN stamps specially issued by the Nazi Government for use on Nazi Official correspondence only. The stamp design shows, as illustrated, the Nazi Swastika.

YOU can get one of these most interesting stamps from us

ABSOLUTELY FREE for your collection. In addition we will also send you some more stamps **FREE** including the FRANCE "Peace" stamp, HOLLAND (Queen Wilhelmina) and nice JAMAICA.

All you have to do to get ALL these interesting stamps **ABSOLUTELY FREE** is to: (1) Ask for **FREE SWASTIKA PACKET**; (2) Ask for an Approval Selection and Price Lists; (3) Write clearly your name and full address; (4) Place 3d. in stamps (to cover cost of Lists and Postage to you of Gift and Approvals) inside your letter and post it to:

WINDSOR STAMP CO.
(DEPT. M), UCKFIELD, SUSSEX

STAMPS AT WAR DISCOUNTS

COLONIALS, Coronations and K.G.VI Also EUROPEANS and other FOREIGN Pick any from our celebrated APPROVALS 20/- worth as priced for 5/6, and *pro rata* OLD AND RARE STAMPS BOUGHT

SAUNDERS & CO., 51, Draycott Avenue, HARROW

The "DIAMOND AIR" Packet



FREE! A Unique Diamond-Shaped Large Air Stamp, also grand Br. Solomon Is. (as reduced illus.), and 10 other fine stamps—Set "Aeroplane over Beira," old "Cape," Map stamp, etc. Just send 3d. postage and ask to see my special "Mercury" Approvals,

Philip J. Dyke (P.T.S.), 35, Buckleigh Ave., London S.W.20

FREE—STAMPS CATALOGUED 5/-

to applicants for 3d. approvals,

COX, 17, STONELEIGH PARK ROAD, EWELL

A FEW ATTRACTIVE BARGAINS

Coronations complete, 202 val., mint 67/6, used 75/-. Coronations and Silver Jubilees, single sets, ask for special price lists, 1d. each. Almost all K.G.VI mint in stock, send want list. Sth. Rhodesia Coronations, 2 val., 1d. and 2d. mint, 8d. New Zealand complete, 13 val., mint 16/-, used 13/6. Newfoundland new 7c. and 30c. mint 3/-. Zanzibar Silver Jubilee 4 val. mint 3/-. Liberia 1918, 13 val. used to \$5. Gibbons 36/-, our price 4/6. Liberia Airmail 1936 6 val. used 1/-. Morocco K.E.VIII 11 val. mint 1/3. 50 diff. Br. Colonials 1/4. 100 diff. Br. Colonials 3/-. 100 diff. Whole World 1/9.

Postage extra on all orders under £1. Cash with order.

A. LANG LTD. — 213, PICCADILLY — LONDON W.1

For other Stamp Advertisements see pages 102 and viii.

Stamp Gossip

and Notes on New Issues

Another Stamp Competition

Here is a further Stamp "Quiz," and in view of the keen interest shown in the previous contest of this kind I am increasing the number and value of the prizes. For the best replies to the set of six questions below I am offering awards of 21/-, 10/6 and 5/-, and there will be other prizes for efforts that fall short of the three best entries, but are deserving of recognition.

1. What country issued the first stamp on which modern aviation was featured?
2. One stamp of Great Britain might be included in a Zoo collection. Which is it?
3. Which countries have issued stamps showing (a) a geyser, (b) a volcano?
4. When and where was mail first carried by air in a regular service?
5. What British Empire stamp bears portraits of four British monarchs?
6. Which country issues the smallest stamps in current use?

Entries must reach me by 31st March and they should be addressed "March Stamp Contest, Meccano Magazine, Binns Road, Liverpool 13."

The Month's New Stamps

We illustrate four recent stamps of great interest. Two of these are the Newfoundland stamps to which I made reference in January. The first is a 7c. air mail stamp, blue in colour, showing a view of St. John's, the capital, and the second, 30c. in value and carmine in colour, illustrates the Memorial University College.

At the head of this page is one of a set of five stamps celebrating the Silver Jubilee of Queen Salote, of Tonga. All bear the same attractive design, showing a full length portrait of the Queen herself, with the dates 1918-1943 at the foot. Each is printed in two colours as follows: 1d., carmine and black; 2d., violet and black; 3d., yellow-green and black; 6d., orange and black; 1/-, brown and black.

The stamps appear to have been printed on two kinds of paper, one thin with the watermark showing through on the back, and the other more opaque and thicker.

The Tonga or Friendly Islands are in the Southern Pacific and form a kingdom over which a British protectorate has been exercised since 1900. They are about 390 miles from Fiji.

Our fourth new stamp



this month, seen at the foot of the page, also is a commemorative, this time from Southern Rhodesia. It marks the passage of 50 years since the rising of the Matabele under King Lobengula. The design shows a typical member of the mounted police who took part in the operations that ended on 4th November, 1893, with the occupation of Lobengula's kraal at Buluwayo.

Previous issues of Southern Rhodesia have been printed in London, but owing to

wartime difficulties the present issue has been produced by the Government Printer at Pretoria. It is in two colours, dark green and brown, and the watermark shows the head of a springbok, the well-known South African mark. Previous issues of Southern Rhodesia have been on paper with no distinctive watermark.

Stamps in the Album—(Continued from page 103)

student of stamp design.

The pages of the album must be varied in pattern, for nothing can be more monotonous than the constant repetition, page after page, of any one arrangement, however attractive in itself. Fortunately there is no limit to the number of excellent page designs, and the different sizes and shapes of stamps too make variations necessary, but the point is one that should be kept in mind.

Some collectors rule lines round sets or special stamps in order to give them prominence, and to make a page more attractive by providing a kind of design for it. This practice should be followed sparingly unless the collector has

real artistic skill, and in particular the use of various coloured inks should be avoided. Otherwise the album may become one in which the stamps merely provide backing for elaborate drawing! It must be remembered that the stamp is the thing, and ornament should be introduced to show the stamps themselves, and not to bury them.

Now we come to writing-up. There is nothing mysterious in this, and indeed there are various aids that make it comparatively easy. Apart from the country and description, that is whether commemorative, charity, etc., the only details that are really necessary are the date of issue, the watermark and the perforation. If all the stamps of a set are alike in this then the information can be given at the head of the set immediately below the name of the country and description. For this neat plain writing is sufficient, but if the collector is good at printing or lettering he can show here what he can do, always taking care not to submerge the stamps themselves. Those who do not feel skilful enough would be well advised to use the printed material that is available. This includes headings for countries, groups, dates, watermarks and perforations, and supplies practically all that is generally necessary. Writing-up can be carried further by entering details of design and of special features of individual stamps. For instance, where a stamp illustrates a famous bridge, interesting notes on the bridge itself could be added.



Air Power in the Great Invasion—*(Continued from page 76)*

which has not been adequately celebrated—the first U.S. bomb was dropped by the U.S.A. Air Force on German ground. Air Chief Marshal Sir Arthur Harris, in a cordial message of congratulation, said: "We have now conclusive evidence that we shall no longer be alone in carrying the war to German soil." Their target was Wilhelmshaven. In 1939 three and a quarter years earlier, during the "phoney war," or "Sitzkrieg," when there seemed to be an agreement that neither side should bomb the soil of the other, but only sea-borne targets, "our Hampdens" used to go into the Heligoland Bight and bomb the German Fleet lying in Wilhelmshaven Roads. So the U.S.A.A.F. had a good precedent.

Since January, 1943, the big bombers of the U.S.A.A.F., protected by .5 in. guns, and compelled thereby to carry only about half the bomb-load of our "Lancasters" and "Halifaxes," have made frequent and gallant forays into Germany, against particularly important targets. And the results have been very good. These, added to the night-after-night attacks by the R.A.F. heavy bombers and "Mosquitoes," have certainly softened German resistance, both morally and mechanically, by breaking the nerves of the factory workers and smashing the factories. And thus the task of the invading Armies and of the Tactical Air Forces will have been made that much easier when they close in for the kill.

Remarkable Runs of Years Ago—*(Continued from page 79)*

a speed was unusual at Potters Bar even with, say, 100 tons less. Down through the London suburbs speed rose to 85 just before Wood Green and was no less than 69 through Finsbury Park.

A normal finish brought us into King's Cross just after 11.27½. We had run in from Hitchin, 32 miles, in 30½ min. instead of the allowed 32, and from Hatfield, 17½ miles, in the very fast time of 16½ min. where 18 were allowed; and although the overall time from Grantham was 104½ min., after allowing for the severe delays the net time was no more than 97 min. for 105½ miles, representing a gain of 3 min. and a net average speed of 65.3 m.p.h. with 440 tons under most arduous conditions.

By the time I had walked the length of the train Driver Molson had been relieved for lunch and a rest before returning with the 1.30 p.m. express, and was just leaving his lovely engine.

"Well done, what a wonderful run!" I exclaimed, flourishing my rough log.

"Were you on board, Mr. Weight?" he replied. "Oh, if I had known that, I'd have tried to do better." "Mr. Molson," I rejoined, "you have done magnificently. I would not have believed it possible under such tough conditions!" He seemed much gratified but he thoroughly deserved my humble tribute.

*(To be continued)***Creeper Cranes for Bridge Building—***(Continued from page 81)*

was hauled forward under the action of hand winches. When in a working position, the crane was securely locked to the "fleeing tracks." Electrical interlocks ensured that the locking was carried out before current was switched on to the hoisting motors.

In addition to the usual cut-out switches to prevent over-hoisting, over-lowering, over-derricking and over-travelling, visible and audible overload signals were provided on the hoisting motions, which, if ignored, led to a shut down of the hoisting movement. The signals were provided by "Wylie" safe load indicators, both on the main and auxiliary hoists, all signals for which were given by a panel in the driver's cabin. A green globe was illuminated while the loads being handled were within the normal working range, and this globe went dark and a red

one lit up when the loads reached or exceeded 95 per cent. of the full rated values. If the loads just exceeded the rated values, a bell rang in addition; but if they exceeded the rated loads by more than 3 per cent. the indicators opened a relay circuit, thus cutting off the main current and bringing the crane to a standstill until the controller was reversed. In addition, special indicators were provided in the cabin to ensure that the cranes moved squarely along the chords.

Separate control cabins were provided for operating the two jibs and an independent cabin to house the haulage control.

The Howrah Bridge is now completed and in use, and as a result of the efficiency of the erecting cranes the whole structure, consisting of 35,000 tons of steelwork, was completed according to plan and without the slightest mishap.

HUMOURS OF A NARROW GAUGE RAILWAY

What few small and private narrow gauge lines that still exist as more or less public concerns are largely found in North Wales and adjoining English counties. One is the 2 ft. 4 in. Snailbeach and District Railway, which is not, as its name might be thought to imply, on the coast, but in Shropshire and mainly concerned with the carriage of locally quarried stone. A train is run over a three-mile route on Mondays, Wednesdays and Fridays. The rolling stock consists of about 50 wagons, chiefly of the hopper type, and there are three locomotives, two 4-6-0Ts built by the Baldwin Works, U.S.A., and numbered 3 and 4, and No. 2, a Kerr-Stuart British 0-4-2T.

The following amusing description of observations on the spot is reproduced from the "Railway Observer." "The shed only holds two engines, those in use No. 2 and No. 4. No. 3, almost identical to No. 4, was some distance away outside the driver's house. These two were rebuilt by W. G. Bagnall in 1918. Information received from the driver was to the effect that he always keeps the engine which is in service by his house because it is handy for lighting up, also he does not use the 0-4-2T very often because its tanks do not hold sufficient water to last all day!"

COMPETITION RESULTS**OVERSEAS**

"Advertisement Letter Square" Contest.—1. A. W. Stewart, Masterton, New Zealand; 2. E. E. Williams, Wanganui, New Zealand; 3. I. Boocock, Oxford, New Zealand.

April "Stamp Picture" Contest.—1. P. R. Johnson, Toronto, Canada; 2. H. Smith, Lovedale, South India; 3. R. H. Frazier, Auckland, New Zealand.

May "Errors" Contest.—1. J. A. Markham, Windsor, Canada; 2. J. R. Clarke, Roseville, Australia; 3. S. T. Carmichael, Sydney, Australia.

May "Go As You Please" Contest.—1. Betty Sykes, Johannesburg, South Africa; 2. H. Smith, Lovedale, South India; 3. F. T. Mackintosh, Vancouver, Canada.

June "Photo." Contest.—1. R. E. Mill, Essendon, Australia; 2. A. C. Seth, Calcutta, India; 3. F. R. Smith, Capetown, South Africa.

June "Railway Vehicles" Contest.—1. G. Myburgh, Claremont, South Africa; 2. M. Laubscher, Johannesburg, South Africa; 3. A. A. Shawky, Egypt. Consolation Prize: E. W. Woodward, Sydney, Australia.

RESULTS OF DECEMBER MISSING WORD COMPETITION

For the best and most apt sets of answers of equal merit, the 1st prize has been awarded to Miss J. Hawkes, Byfleet, Surrey, and Miss B. Newman, Portsmouth, Hants, each of whom has received £2 10s. 0d. The 2nd and 3rd prizes were divided equally among the following, who gave the next best set of answers of equal merit:—Miss M. N. Wood, Bakewell, Derbyshire; Master D. Fry, Axminster, Devon; and Miss M. Christiansen, Yardley, Birmingham.

Competitions! Open To All Readers

A New Shunting Puzzle

Our October railway shunting puzzle, the results of which were announced last month, proved extremely popular with readers, and we are therefore presenting them a similar problem as our principal contest this month. Every reader is invited to send in a solution of this. Railway enthusiasts of course will do so eagerly, but others should not be deterred from attempting it, as the conditions are simple and railway knowledge is not absolutely necessary.

The layout concerned is illustrated in the diagram on this page. A train of five wagons, headed by the tank locomotive L, has just arrived from C, the fifth wagon, No. 5, being a brake-van. Standing in the sidings are seven other wagons, numbered 6 to 12. A new train to include these wagons has to be made up and despatched in the direction of B. In it wagons 1 and 2 are to follow the locomotive, with wagons 6 to 12 in order behind them, wagons 3, 4 and 5 bringing up the rear of the train, which will then have the brake-van at the end.

While shunting is going on the wagons in the sidings must not be brought on to the main line, which they will only enter when the train has been made up

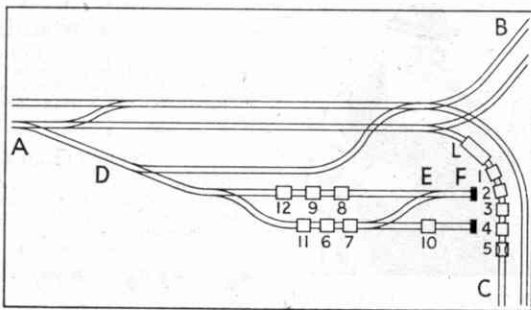

and is on its way towards B. The section of line marked AD is long enough to accommodate two wagons and the locomotive, but nothing more, and in EF there is room for only one wagon. The locomotive has not to be turned; as it is a tank engine it can proceed equally well either forward or backward.

What is required is the simplest and easiest way of marshalling the wagons in the order indicated. Naturally, the fewest moves have to be made, so that neither fuel nor time is wasted, and there is scope for real ingenuity in finding the solution.

The Contest is divided into two sections, for Home and Overseas readers respectively, and in each prizes to the

best solutions. If there is a tie for any prize, neatness and novelty will be taken into consideration by the judges. Entries must be addressed "March Shunting Puzzle, Meccano Magazine, Binns Road, Liverpool 13." The closing dates are: Home Section, 30th April; Overseas Section, 31st October. Do not forget to write your name and address on each sheet of your entry.

A Cypher Mystery

Here is an absorbing mystery for readers to solve. A sheet of paper handed to us had on it the seemingly meaningless jumble that is printed below, and we were assured that this could easily be interpreted to make sense. It proved in fact to be a cypher message, of no particular importance in itself, but interesting as an example of the way in which words and places can be disguised by very simple means.

qjz42if6n 2m6 2gr2tn ja oc6 bm62o6no dno6m6no, rc6oc6m oc6t 2m6 ad6m46gt 24odq6 hjno6n, gd23g6 of np56i 6mpkodji 2o 2it hjh6io, jm 2m6 6sodi4o. 6q6i oc6ne oc2o 2m6 ocjpbco of 36 6sodi4o 2t 62ndgt 4jhg of gda6 2b2di rdoc 5dn2nomjpn m6np6on.

We are sure that readers will revel in the task of decoding this. There is nothing to be alarmed at in it. As a hint we may point out that in the simplest of all cyphers each letter is represented by that a certain number of places forward or backward in the alphabet. A cypher of this kind is easily solved by first writing down the message, or part of it, and then under each letter placing the next one in the alphabet, repeating this process until real words appear instead of an apparent jumble. The cypher we have set is not quite so simple as this, as figures appear in addition to letters, but we have no doubt that readers will penetrate the mystery, even if they have to fall back on the well-known fact that the letters occurring most frequently in English are E, T, A, O and N, in that order, those most rarely seen being X, Q, J and Z.

With these hints readers can hopefully set out to tackle the cypher in this interesting puzzle. When they have completed the passage, which they will find to be a simple extract from last month's "M.M.,"

all they have to do is to write it out on a postcard and send it to "March Cypher Contest, Meccano Magazine, Binns Road, Liverpool 13." There will be the usual two sections in this contest, for Home and Overseas readers respectively, and in each there will be three prizes of 21/-, 10/6 and 5/- respectively, together with consolation prizes for efforts that miss one of the principal awards, but are deserving of recognition.

The closing dates are: Home Section, 30th April; Overseas Section, 31st October. Do not forget to write your name and address on your entry.

March Photographic Contest

This month's contest is the 3rd of our 1944 series, and in it, as usual, prizes are offered for the best photographs of any kind submitted. There are two conditions: 1, that the photograph must have been taken by the competitor, and 2, that on the back of each print must be stated exactly what the photograph represents. A fancy title may be added if desired, but entries on which the conditions stated above are not observed will be disqualified. It is not necessary that developing and printing shall have been the work of the competitor himself.

Entries will be divided into two sections, A for readers aged 16 and over, and B for those under 16, and all entries must be clearly marked with the section letter. They should be addressed "March Photographic Contest, Meccano Magazine, Binns Road, Liverpool 13." There will be separate sections for Overseas readers, and in each section prizes of 15/- and 7/6 will be awarded. Closing dates: Home Section, 31st March; Overseas Section, 30th September.

Fireside Fun

SAY THIS ALOUD

I had a wooden whistle, and it wooden whistle. Then I got a steel whistle, and steel it wooden whistle. Then I got a lead whistle, and they wooden lead me whistle. But now I've got a tin whistle, and now I tin whistle.



"Don't you remember me? We were at school together!"

"Here you are, Johnny, a sixpence for your money box."

"What are you after now, dad? One of my oranges?"

Employer, angrily: "Look here, young Rip van Winkle, I only engaged you yesterday, and I think you have been fast asleep ever since."

New Employee: "Yes, sir. But your advertisement was for a warehouse man to sleep on the premises."

German guard in Denmark: "Ach, I vish de var was ofer."

Dane: "Why?"

German: "I would go through Greater Germany on my bicycle."

Dane: "Yes, but what would you do in the afternoon?"

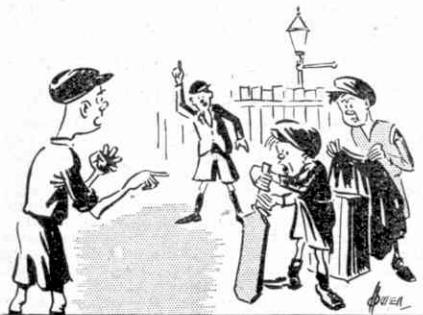

"L.B.W.!"

"Gerraway! Hit the bat. You 'aven't done it yet."

THIS MONTH'S HOWLER

Balboa was called the Great Pacificator because he discovered the Pacific Ocean.

BRAIN TEASERS

CAN YOU MAKE ANYTHING OF THIS?

Add together a leathermaker, the Sun, Moon and Stars, the weight of a pendulum, the head of a state and something he wears. This amounts to £1/6/6¹. How is this sum made up?

SOMETHING MORE STRAIGHTFORWARD

A ladder leaning against a wall has its foot 10 ft. away from it. If the ladder were pushed right up against the wall its top would rise 2 ft. How long is the ladder?

T.K.C.

EASY REALLY

A man putting eggs in a basket doubles the number every minute. It is a large basket so that clearly he becomes a fast worker, but it takes him an hour to fill the basket. How long does it take him to half fill it?"

OVERWORKED LETTERS

Here are clues, of the crossword type, to five words containing the same four letters differently arranged: pillar, vessels, speck, halt, summits. What are the words indicated?

T.K.C.

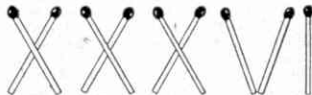
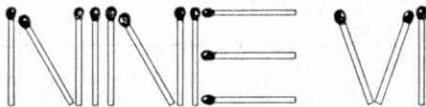

SOLUTIONS TO LAST MONTH'S PUZZLES

The answers to the crazy sums in our first puzzle last month are shown in the above diagrams, and no further explanation is needed.

"MONEY" in our second is clearly about 10 times "MORE" and this suggests 1 for M and 0 for O. Then the remaining figures can easily be fitted in to make up the following sum:

$$\begin{array}{r} 9,567 \\ 1,085 \\ \hline 10,652 \end{array}$$

The least number of packing cases required by the fruit merchant in our third puzzle is 18, each containing 442 oranges.

A glance at the accompanying diagram shows how easy it is to get 10 rows with only 9 dots, 3 dots in each row.

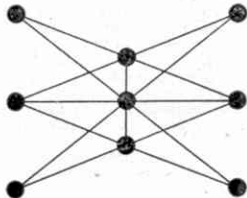

WILSON LORRY KITS

THERE IS NO COMPARISON

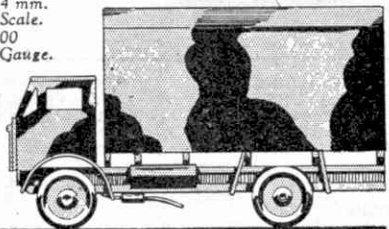
TRADE **PRINTASTRUCT** MARK4 mm.
Scale.
00
Gauge.

COMMANDO BATTLE WAGGON KIT—in full battle colours, price 4/- plus 8d. tax, 4/8, postage and packing 3d.

PLATFORM KIT, cost 2/6 plus 5d. tax, 2/11, post 3d.

Full catalogue price 4d. and stamped addressed envelope

Agents:

Hamley Bros., Regent Street, London.
George D. Campbell, 46, High Street, Dumfries

WILSON'S LORRIES LIMITED

Dept. M, BRACKNELL, Berks.

BOND'S

We will again be able to supply all the requirements of the Model Maker when the war is over and many new items are now on the drawing board getting ready for the time when we can put them into production together with all our other well known specialities.

We can supply small quantities of materials, screws, rivets, gears and tools, etc., so we will be pleased to know what you are requiring.

No catalogues are available now.

BOND'S O' EUSTON ROAD LTD.

Estd. 1887

'Phone:
EUSTON 5441-2.

**357, Euston Road
LONDON N.W.1**

SCENIC RLY. MDG.

Build a realistic setting around your min. Railway. The popular "00" scale permits an extensive layout. A new Planbook has been written by an expert builder and operator. Price 5/6, by post 5/9. (Below)

RLY. PLANS "Lineside" Plans for "00" Rlys. give necessary instructions for the construction of complete range of Architect. and Eng. features conforming to B.M.R.S.B., "Dublo," "Trix," etc. (Below)

MINIATURE AIRCRAFT

Warring reveals art of making models which bear closest scrutiny and look "real" to camera eye. Nearly 60 illus. with plans for representative modern aircraft, Price 4/6, by post 4/8. Also "Three Rapid Methods of Making Identification Models." Price 1/6, by post 1/8. (Below)

SHIPS & 'PLANES "Planes 1/72 Ships 50 ft. to 1 in. Over 70 Plans released—6d. to 1/- (Below)

GALLEONS "Planbook." "Building a Galleon." Full instns. for building fine models of these grand old ships. Profusely illustrated. Set of 8 progress plans for "Golden Hind," size 20 in. x 30 in. Price 12/6, by post 13/-. (Below)

YACHT How to build a fast racing model by new rapid method at cost of few shillings. Working drawings, plans and licence to use patent. Price 3/6, by post 3/8. (Below)

OIL ENGINE Working model (runs on air). Made of simple materials and tools. New technique fully illustrated in book. 2/-, by post 2/2.

Send 3d. and unstamped addressed envelope for list of over 100 Plans and "Planbooks." MODEL CRAFT LTD., 77 (M.M.), Grosvenor Road, London S.W.1

**BOYS**

Veteran riders will tell you that there is no more faithful friend to the cyclist than the MILLER DYNAMO

LIGHTING SET, the lamp that has stood the test and proved the best during 60 years of cycling service.

Supplies are difficult now, therefore consult your Dealer as we, the manufacturers, do not supply direct.

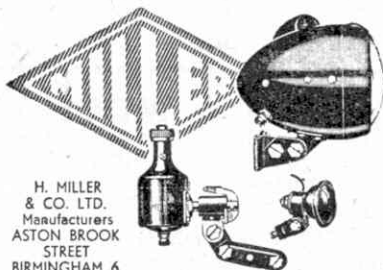

H. MILLER
& CO. LTD.
Manufacturers
ASTON BROOK
STREET
BIRMINGHAM 6



MANUFACTURE SUSPENDED UNTIL AFTER THE WAR

ELECTRADIX BARGAINS



MAGNETS. Massive horse-shoe permanent steel magnets. Various sizes, 3/6 and 4/6 each. Wonder midget 2 ozs. Disc P.M. Magnets, 2/6 each. A.C./D.C. **MAINS MAGNETS,** 2-pole, 110 volts or 220 volts, 5/6. Small 12-volt solenoids with 2 in. x 1/2 in. plunger, 6/6.

RELAYS. Telephone No. 6 twin bobbin polarised S.P. Change-over, 6 volts 25 m/a, 8/6. No. —A "on-off" S.P. 2 volts, 5/-. Less contact blades, 1,000 ohm coil C.T., 2/6. Photo Cell Relays, 10,000 ohms, enclosed, new, 22/6.

LIGHT RAY CELLS, Selenium Bridge, in bakelite case. Raycraft Model, 21/-. Raycraft Ray Set, with relay, 42/-. **TURNTABLES.** Ball-bearing, for table sets, model railways, etc., bakelite body, 4 1/2 in. dia., 2/- each.

MORSE KEYS. Type B1, a strong Key, 5/-. Type M, bakelite base, 6/6. Type P.F., plated movement, first class, well balanced, 9/6. Type IV, a very fine key, 12/6. **BUZZERS.** Bakelite, 3/6. Brass cased small, 5/6. Heavy type bakelite cased, 5/6. The smallest Wavemeter Buzzer, famous Townsend, shrill, tiny, 10/-. **PANEL SWITCH RHEOSTATS.** "Off" and 0 to 1 ohm, 3 amp., 6 volts. Dimmers Charger Sub-circuit Regulators, Model Speed control, etc. Makers, Aetna Co., U.S.A. New for 2/6. Worth 5/-.
Please include postage for mail orders.



ELECTRADIX RADIOS

214, Queenstown Rd., Battersea, London S.W.8
Telephone: Macaulay 2159

STUDY AT HOME FOR MATRICULATION



Wolsey Hall (Est. 1894) will coach you by post for London Matric., School Cert., R.A.F. Maths., Engin. Prelim., Lond. B.Sc. Degree, etc. Tuition continued free if you fail; low fees, instalments. **PROSPECTUS FREE** from Director of Studies, Dept. GK1,

WOLSEY HALL, OXFORD

BUILD A MODEL

Corvette Kits 2/3. Submarine Kits 1/9.

Prices include postage.

Agent for Wilson Lorry Kits, Aeroplane Kits.

*All dopes, Cements, etc.

1944 list will be ready about March or April.

Three Penny Stamps will bring you a copy.

GEORGE D. CAMPBELL

Dept. MM, 46, High Street, DUMFRIES

35 mm. Films. All description from 6/-. Baers, 176, Wardour St., London W.1. Hire Programmes 10/..

SCALE BUILDINGS:	"100"	"0"
PLATELAYERS' HUTS ..	2/6	5/6 & 6/9
COAL OFFICES ..	3/6 & 4/-	6/6 & 8/6
WEIGHBRIDGE OFFICE ..	5/-	—
BUNGALOWS ..	8/6	—
	Postage 4d. extra	
BUILDING LITHOS ..	3d.	3d.
	Postage extra	

BOOKS:
"HISTORY OF THE G.W.R."
3 Parts each 10/6, by post 11/-
BRITISH RAILWAY ROLLING STOCK
4/6, by post 5/-

WANTED—GOOD USED MODELS

TYLDESLEY & HOLBROOK

109, Deansgate, Manchester 3 Bla. 7312

CIGARETTE CARDS

New collectors. Start your collection with an assortment of sets or odd cards.

16 sets, price 10/6 (post 6d.). Value over 20/-,
8 sets for 5/6 (post 5d.). 4 sets for 2/9 (post 4d.).

500 well assorted cards 5/6 (post 6d.).

List of over 300 different series, price 3d.

Cards purchased—all kinds—good prices paid.

R. W. HOUSTON, BCM/EXCHANGE, LONDON W.C.1

LEARN

M·O·R·S·E

Complete
Practice
Unit

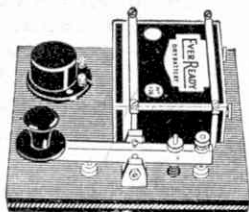

as supplied to H.M. Forces

No. 1261. Complete Key and Buzzer Unit, ready for immediate operation. Heavy commercial key with nickel silver contacts and sensitive triple adjustment. High-tone Buzzer with silver contacts, mounted on bakelite base with cover. Battery Holder, complete with 4.5 Ever Ready battery. All metal parts heavily nickel plated. Polished Mahogany Base, 6 1/2" x 6 1/2".
Price 29/6

Send 1d. stamp for Illustrated List

SIGNALLING EQUIPMENT LTD.

Specialists in Morse Equipment

(Dept. 13)

Merit House, Southgate Road, Potters Bar

Join the Well-Paid Ranks of the TRAINED MEN

MANY THOUSANDS MORE ARE URGENTLY NEEDED. PREPARE YOURSELF FOR A BETTER POSITION AND BETTER PAY

Ambitious men everywhere have succeeded through I.C.S. Home-Study Courses. So also can you. We offer you the benefit of our 53 years' matchless experience as the creative pioneers of postal instruction.



*If you need technical training, our advice on any matter concerning your work and your career is yours for the asking—free and without obligation. Let us send you full information regarding the subject in which you are specially interested. **DON'T DELAY.** Make "ACTION" your watchword.*

The successful man DOES to-day what the failure INTENDS doing to-morrow. Write to us TO-DAY.

Special terms for members of H.M. Forces

YOU MAY USE THIS COUPON

(Penny stamp on unsealed envelope)

INTERNATIONAL CORRESPONDENCE SCHOOLS LTD.

Dept. 218, International Buildings, Kingsway, London W.C.2

Please send me the Syllabus of your Courses in.....

Name..... Age.....

Address.....



The I.C.S. offer Courses of Instruction in a wide range of subjects, including:

Accountancy	Insurance
Advertising	Joinery
Aeronautical Engineering	Journalism
Aero Engine Fitting	Machine Designing
Aero Fitting and Rigging	Machine-Tool Work
Aeroplane Designing	Marine Engineering
Air-Conditioning	Mechanical Drawing
Architecture	Mechanical Engineering
Architectural Drawing	Mine Electrician
Boilermaking	Mine Surveying
Book-keeping	Mining Engineering
Building Construction	Motor Engineering
Building Contracting	Motor Mechanic
Business Training	Moulding
Business Management	Patternmaking
Cabinet Making	Power-House Attendants
Carpentry	Quantity Surveying
Chemical Engineering	Radio Engineering
Civil Engineering	Radio Servicing
Clerk of Works	Refrigeration
Colliery Management	Salesmanship
Commercial Art	Sanitary Engineering
Concrete Engineering	Secretarial Work
Cotton Manufacturing	Sheet-Metal Work
Diesel Engineering	Steam Engineering
Draughtsmanship	Structural Steelwork
Drawing Office Practice	Surveying
Electrical Engineering	Telegraph Engineering
Engineer in Charge	Telephone Engineering
Eng. Shop Practice	Templating
Fire Engineering	Textile Designing
Fitting and Turning	Toolmaking
Foundry Work	Turner
Garage Management	Welding, Gas & Elec.
Gas-Power Engineering	Woodworking
Ground Engineer	Woolen Manufacturing
Heating and Ventilating	Works Engineering
Hydraulic Engineering	Works Management

And most of the Technical, Professional and Matriculation Exams.

STAMP ADVERTISEMENTS 3

(See also pages 102 and 104)

2 UNUSED
NEWFOUNDLAND FREE!

This attractive set will be presented entirely free to serious approval applicants. Only one gift to each applicant. Write to-day.

**W. LE MERCIER, 58, LUMSDEN AVENUE
SHIRLEY, SOUTHAMPTON**

Postal Business Only.

FREE PKT. OF 10 STAMPS
(BRITISH COLONIALS) FREE
PKT. OF STAMP MOUNTS

To the first hundred applicants requesting approvals the above stamps and mounts will be sent absolutely free together with 2 New Issues.* Liberal discount on purchases off approvals. Send at once to secure this valuable gift.

Martin Courtney (Dept. MM), 36, Albert St., Warwick, Eng.

STILL MORE BARGAINS

Rex 1943 B. Colonial Stamp Catalogue, 2/-.

Whitfield King 1944 World Catalogue, 13/1.

Stamp Albums, 1/6 to 1/-.

Save money on your collection by sending 1d. stamp for our Bargain List of sets and packets.

STAMP IMPORTERS LTD.

12, JAFFRAY ROAD, BIRMINGHAM 24

BARNET & FORD

The Stamp Shop, 5b, High Street, Conway, N. Wales

BARGAINS IN MINT SETS

5 Tonga, Jubilee 2/3. 6 F. F. Somaliland Prov. o/p 1/6.

2 N. Z. Anzac 9d. Canada (Royal Visit) 1/-.

6 F. F. New Caledonia Prov. o/p 2/6. 10 F. F. Cameroons

(4 Provis. and 6 permanent issue) 2/6. All Coronation

sets in stock. Send us your want list.

Reliant 1944 Catalogue 6/3. Rex (Geo. VI) 1944 2/9.

Jan. and Feb. offers still available. List 1d.

CORONATION SETS USED

Malta ... 2/- New Guinea ... 2/9

S. Africa ... 7/- S. W. Africa ... 6/6

ALL SETS MINT OR USED IN STOCK.

Postage extra. Price List 1d.

I. GRAY, BCM/FIL, LONDON W.C.1

100 STAMPS — ALSO MYSTERY GIFT — 2/6

Post Only. R. FLATTEAU Post Free.

32, DRYDEN CHAMBERS, OXFORD STREET, W.1

READERS' SALES AND WANTS

SALES

"How It Works and How It's Done"; "General Engineering Workshop Practice"; "Meccano Magazines," 1936-1939 (50); best offers.—Worsfold, 5, Bell Lane, Birmham, Nr. Chichester.

What offers? "M.M.'s," June 1937 to March 1943, inclusive; "Railway Wonders of the World," parts 4, 6, and 21 to 30. All good condition.—Williams, 192, Dover Road, Walmer, Kent.

Complete Hornby Dublo Set with extra Rails and Transformer, all in good order.—A. A. Mackinnon, Great Ivy Mill, Tovil, Maidstone.

Model Colliery Pumping Engine and Pump, £7/10/- or near offer.—Bundock, 67, Gilbey Road, Tooting, London S.W.17.

90 numbers "Meccano Magazine," 1932-42; offers only for whole.—Webster, 10, The Drive, Orpington.

MECCANO
MAGAZINE

Registered at G.P.O., London, for transmission by Canadian Magazine Post.

EDITORIAL AND ADVERTISING OFFICE:

LIVERPOOL 13, ENGLAND.

Telegrams: "Meccano, Liverpool."

Publication Date. The "M.M." is published on the 1st of each month.

Readers' Sales and Wants. Private advertisements (i.e., not trade) are charged 1d. per word, minimum 1/-; Cash with order. Editorial and Advertising matters should not be dealt with on the same sheet of paper.

Readers' advertisements are published as soon as possible; inclusion in the first issue after receiving them cannot be guaranteed.

Small Advertisements. 1/8 per line (average seven words to the line), or 20/- per inch (average 12 lines to the inch). Cash with order.

Display. Quotations for space bookings, and latest net sale figures, will be sent on request.

WANTS

To Complete Models in Course of Construction, $\frac{1}{4}$ in. Bevel Gears, Part 30; $\frac{1}{4}$ in. Bevel Gears, Part 30C; and Gear Wheels all sizes; Nuts and Bolts; also complete Geared Roller Bearings, Part 167; and Four Electric Motors E.20B, reversing. Good prices paid.—

Harrington, "Meaford," Uppingham Road, Leicester.

"Railway Wonders of the World," part 2; "Wilson's Building Construction, Carpentry and Joinery," 4th edition; Maps, Photos, Books, etc., on S.R. and Welsh

Light Railways, past and present; "Railways," part 1 to 20 and 22. Particulars to—Worsfold, Bell Lane,

Birdham, Nr. Chichester, Sussex.

Good Collection of Stamps; give particulars and price. Loose Stamps also purchased.—Price, "Springfield," 36, Tyrtran Avenue, Llanelly, South Wales.

"M.M.'s," April to September 1942, inclusive, in good condition; state price. Write—Hammond, Station House, Barnham Thetford, Norfolk.

Meccano Gears of any kind; single ones accepted; will exchange T20 Transformer or Clockwork Motor for above if desired.—Baker, 1, Boundary Road, Merton, S.W.19.

Clean copy of November 1940 "Meccano Magazine."

—"Whinbrow," Chrystals Estate, Horsnae, Yorks.

For younger brother, "Mickey Mouse" Comics; any date prior to 1943.—G. Watson, 257, Wragby Road, Lincoln.

Hornby Railway, 11 Trucks, Two Pullmans, "Flying Scotsman," Two Small Locomotives, Seven Points, 70 Rails and various extras; all in good condition.—

A. A. Mackinnon, Great Ivy Mill, Tovil, Maidstone.

Hornby E220 Midland Compound Loco. Condition

and price to—19, Weston Crescent, Bristol 7.

Dublo "Duchess of Atholl" and two L.M.S. Coaches.

Price to—Stokes, 33, Silverknowes Drive, Edinburgh 4.

I will buy or exchange 1-2 gallon Glass Fish Tank.

Offers to—PHELPS, "Merley," Bearwood, Kinson,

Bournemouth.

LONDON—TOY AND MODEL SHOP

FLYING & SOLID KITS (Keilcraft, Astral, Skylead, Skyrova, Halfax, Grace, Silverwing, Airyda, Truscate, Skycraft).

WATERLINE & LEYDEN SHIP KITS.

Plans, Aero-Modeller Books, Accessories,

"Building a Galleon" 12/6.

Postage must accompany orders and enquiries.

57, SYDENHAM RD., LONDON S.E.26. Syd. 8320

Convert your Buzzer Set into a long distance Morse and Speed Instrument. Converter 1/6 post free, or booklet and blueprints 1/6. Phillimore, 2, Castle Drive, Whitby, Ches.

GEORGE III became King in 1760

This is one of the facts of history which you are expected to know. A lesser known one, but perhaps of more interest to schoolboys, is that HAMLEYS was established in the same year.

Unlike George III, HAMLEYS still reigns—the King of Toy Shops—and eagerly awaits the post-war days when it will resume its pre-war glory.

Hamleys

ESTD 1760
HAMLEY BROTHERS LTD
200-202, REGENT STREET, LONDON W.1
(Our only address). Tel. Regent 3161

Have you sent your 2d. stamp for the list of Aircraft and Warship Kits yet?

"R.P." PUBLICATIONS



"AMERICAN TYPE DESIGNATIONS"

Explaining the System of Numbering U.S. Aircraft
The American system of designation—apparently somewhat complicated—is quite clear and not difficult to follow, once it is understood. This booklet gives a clear understanding of these designations.

Complete Tables of all aeroplanes of the United States Army Air Forces and of the United States Navy, with Makers' Numbers and Designations, Engines, Maximum Speeds, Spans, U.S.

Army numbers and British Names. Price 1/-.
"AIRCRAFT COMPARISONS." (Revised Editions). Explaining Mark numbers. Part I: Single-engined a.c. Price 1/-. Part II: Multi-engined a.c. Price 1/6.

"WAR IN THE AIR: FIGHTERS." Price 5/-.
"AIR NAVIGATION." Price 1/6.
"SEA NAVIGATION." Price 1/6.
"HISTORY OF THE R.A.F." Price 3/-.
"NAVAL EPISODES." Price 1/6.
"AIRCRAFT CARRIERS." Price 1/6.
"AIRCRAFT CLASSIFICATION." Price 1/6.
"AIRCRAFT RECOGNITION DRAWING BOOK." Price 2/-.
"MOSQUITO" COLOUR PLATE (14 in. x 11 in.). Price 1/2.
MILLS H.E. GRENADE COLOUR PLATE (50 in. x 20 in.). Price 2/6.

Send 2d. for complete list of our Publications.
REAL PHOTOGRAPHS CO. LTD., SOUTHPORT

Two opportunities for Amateur Photographers

Your photography will become much more interesting if you do it all yourself. To help you, we will send, for 3d. in stamps, these three publications. A 32-page booklet called 'Home Photography' which tells you how to develop your own negatives, how to make Gaslight and Bromide prints, how to do Flashlight Photography and how to make Enlargements. A folder about Azol, the concentrated one-solution developer, with full Time and Temperature tables for tank or dish development. There is also a fully illustrated list of Chemicals, useful sundries and accessories to help you in the work.



THESE THREE PUBLICATIONS
WILL BE SENT TO YOU FOR
3d. IN STAMPS

Be sure and mark your letter Dept. FJM
JOHNSON & SONS Manufacturing Chemists LTD., HENDON, N.W.4

Special Trial Offer:

For 2/3 P.O. Johnsons will send you post free (G.B. only) a trial set of Chemicals, including 1-oz. bottle of AZOL, to develop eight spools 2½ in. by 3½ in., 4-oz. tin ACID-FIXING, making 30-60 ozs. solution, one packet AMIDOL DEVELOPER, enough for 2 to 3 doz. bromide or contact gaslight prints.

THE MECCANO MAGAZINE

MECCANO

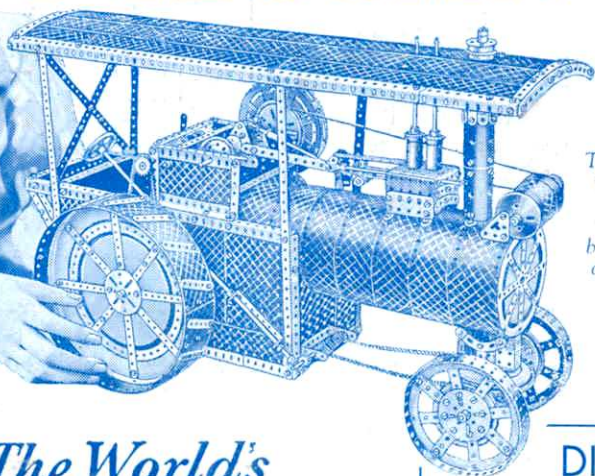

This splendid model of a Traction Engine is built entirely of standard Meccano parts.

The World's Greatest Toys

We are sorry that we cannot supply these famous toys to-day, but they will be ready for you again after the war. Look out for the good times coming!

HORNBY TRAINS

A Hornby Pullman Train passing under a Gantry Signal.

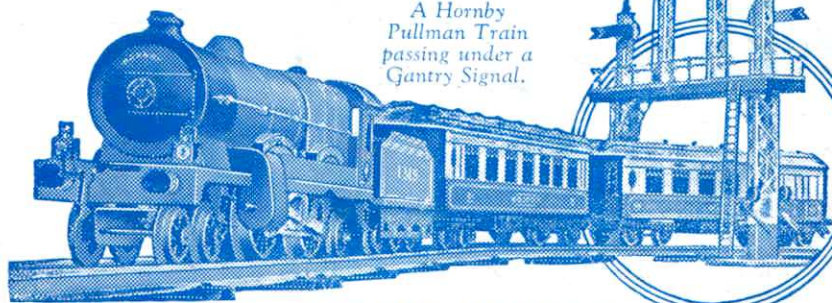

MECCANO LIMITED, BINNS ROAD, LIVERPOOL 13

DINKY TOYS



De Havilland "Flamingo."
Used by R.A.F. for transport and communication work.



Buick "Viceroy" Saloon Car.