

VOL. XXX. No. 4

APRIL 1945

MECCANO

MAGAZINE



THE DRIVER

6^d

During the National Emergency only limited supplies of

VITALITY BULBS

are now likely to be available.

If your Dealers cannot supply you with the type you require, do let us have full particulars, together with their name and address, because it might just happen that we know of factors who may be able to supply them.

VITALITY BULBS LTD

NEVILLE HOUSE,
NEVILLE PLACE,

WOOD GREEN
LONDON, N.22

CHEMICAL APPARATUS



POST FREE
APPARATUS
OFFER

10/6
INCLUDING
CHEMICALS

21/-

(England, Scotland
and Wales only).
Send 1d. stamped
envelope for Price
List.

BECK (Scientific Dept. G), 60, High Street
STOKE NEWINGTON, LONDON N.16
Booklet, "Experiments in Chemistry," 7d. P.O.

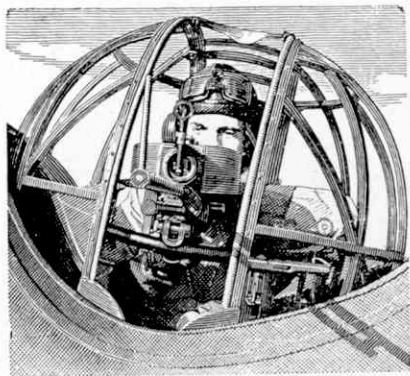

Recording the movements of men and materials. Searching out strategic points and spotting enemy concentrations. These are just a few of the jobs done on Ilford Film by R.A.F. Photographic Reconnaissance Units.

When all this work is finished, Ilford photographic materials, better than ever before, will come back into general use again.

ILFORD makers of **SELO** films
LIMITED

Bullet- proof tyres for the Services

were
invented by

DUNLOP



FROG

MODEL AIRCRAFT

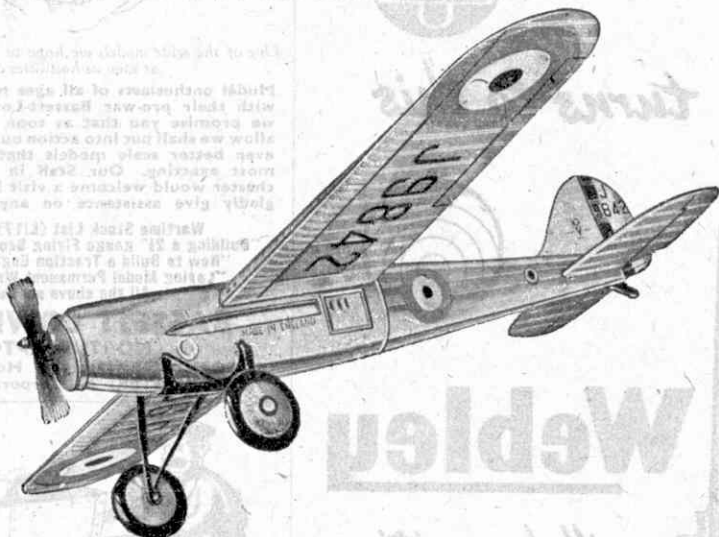

International Model Aircraft have not been producing Model Aeroplanes for 5 years because their experts have been working hard on more important winners, but we hope soon that all the latest models will once again be available to model aircraft enthusiasts. These will include:-

FROG Flying Scale Models, FROG Flying Scale Model Construction Kits, FROG "SENIOR" Flying Construction Kits, FROG "PENGUIN" Non-Flying Scale Model Kits.

Sole Concessionaires:

LINES BROS. LTD.

TRI-ANG WORKS, MORDEN ROAD, LONDON S.W.19



Trade Mark
Regd.

When this aim



turns to this



Webley

will be waiting

to supply sportsmen
the world over with
their celebrated
**WEBLEY AIR
RIFLES, AIR
PISTOLS and
SPORTING GUNS**

Webley & Scott Ltd.
Birmingham
England
(Est. 150 years ago)

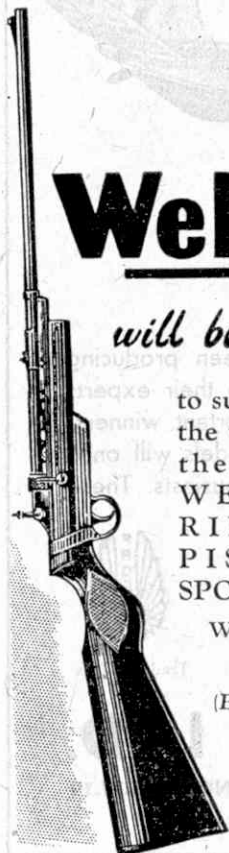

A POST WAR JOY FOR EVERY BOY!



One of the scale models we hope to put into production as soon as hostilities cease.

Model enthusiasts of all ages to-day "make do" with their pre-war Bassett-Lowke models; but we promise you that as soon as circumstances allow we shall put into action our plans for making even better scale models that will delight the most exacting. Our Staff in London or Manchester would welcome a visit from you and will gladly give assistance on any model matters.

Wartime Stock List (L/17). Price 4d.
"Building a 2 1/2" gauge Flying Scotsman." Price 1/-.
"How to Build a Traction Engine." Price 6d.
"Laying Model Permanent Way." Price 3d.
All the above post paid.

BASSETT-LOWKE LTD.
NORTHAMPTON

LONDON: 112, High Holborn, W.C.1
MANCHESTER: 28, Corporation Street, 4.

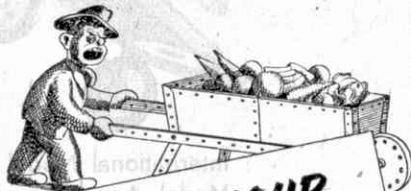

**MAKE YOUR
MECCANO MODELS
Live!**

Add realism to your models with 'PLASTICINE'—the famous modelling medium. This pliant, colourful material is indispensable to all Meccano enthusiasts.

As supplies are strictly "rationed" nowadays please make your "Plasticine" last.

**HARBUTTS'S
'Plasticine'**

TRI-ANG TOYS

We have not been making toys for 5 years but we hope it will not be long now before the world-famous toys appear once again in your local toyshop or store.

Many happy hours are in store for girls and boys of all ages, but remember, it will have to be a TRI-ANG TOY.

The illustrations underneath are just a reminder of what real toys look like.



MINIC
Scale Model Clockwork Toys



LINES BROS. LTD.
World Famous
TRI-ANG TOYS



MINIC
Scale Model Clockwork Toys

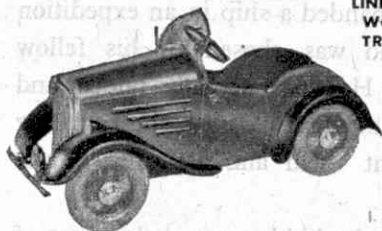

TRI-ANG CHILDREN'S CARS



TRI-ANG DOLLS' PRAMS



**UNIQUE AND UNITY
CYCLE CO. LTD.**
FAIRYCYCLES
TRICYCLES
JUVENILE CYCLES



TRI-ANG "FAIRYCYCLES" (Regd.),



TRI-ANG TRICYCLES (Regd.)

Made at our famous Birmingham Works

LINES BROS. LTD.

AND SUBSIDIARY COMPANIES

UNIQUE AND UNITY CYCLE CO. LTD.

PEDIGREE SOFT TOYS LTD.

TRI-ANG WORKS, MORDEN ROAD, LONDON S.W.19

ROUND THE WORLD WITH **BSA** No. 9



JAMAICA

Of all adventure stories none is more thrilling than the true history of that wild buccaneer Henry Morgan, who, while still a boy, was sold into slavery. Years later he turned up in Jamaica, a desperate man. He commanded a ship in an expedition which seized Providence Island and was chosen by his fellow buccaneers to be their "admiral". He once actually raided and looted Gibraltar! On leaving he found three Spanish ships waiting to intercept him, but he out-fought them and captured a vast amount of treasure.

Much of Morgan's booty is said to be hidden round the coast of Jamaica — what a treasure hunt for a boy or girl with a B.S.A. bicycle! Yes, the same B.S.A. bicycles that are first favourites at home. They are scarce now, but ask your parents to have a word with your local dealer — he'll do his best to get you a B.S.A. bicycle, but you'll have to be patient.

BSA

THE BICYCLE YOU CAN'T BEAT!

B.S.A. Cycles Ltd., Birmingham, 11.



MECCANO

MAGAZINE

Editorial Office:
Binns Road
Liverpool 13
England

Vol. XXX
No. 4
April 1945

With the Editor

All the Fun of the Fair!

The fun of the fair is something to which we all look forward at some time or other, and readers therefore will be greatly interested in the story on page 114 of Frederick Savage, for to him we owe many of the finest developments of fairground rides. He was chiefly responsible for the introduction of steam engines to drive roundabouts and switchbacks, as well as giant swings, and he was always working out some novelty or other for our amusement. Mr. Yarham's article tells us a good deal about this fine engineer, the forgotten genius of the fair world, and I hope to follow it later by another illustrated article.

Among the Model-Builders

I want to draw attention to the section that appears this month under the heading: "*Among the Model-Builders.*" It replaces the "*Suggestions Section*" that has been so popular for many years, and in many respects it will be different from the old feature. It will provide space for readers to put forward their ideas on anything connected with the great Meccano hobby.

After the first few weeks scarcely any two boys use their Meccano in quite the same way. Each one gradually develops a method of his own, and concentrates on certain things that for some reason are of special interest to him. From time to time he gets new ideas, as the result of which his models steadily improve. One of the special purposes of the new section is to gather together some of the best of these ideas.

The war has had a big effect on model-building on account of the famine in Meccano parts. All sorts of difficulties have had to be tackled. Many boys have found new uses for certain parts, and so have been able to build quite good models

in a way that they would never have thought of if new parts had always been available at the local dealer's. Others have used Meccano to make articles they needed but could not buy, or to do temporary repairs of various kinds. So, in one way or another, a lot of very useful Meccano knowledge has been accumulated; but there is a great danger that this will be largely wasted because boys cannot pass on their experiences to other enthusiasts. Here the new pages come in. Through them any boy can convey his Meccano suggestions to every member of the great army of "*M.M.*" readers throughout the Empire and in many other parts of the world.

Read what "*Spanner*" says on page 130 and send your contribution as soon as possible.

This Month's Articles		Page
Welding in Post-War Reconstruction	110
by C. W. Brett, M.Inst.W.		
Driving a Diesel-Electric Locomotive	112
Boeing "Superfortress"	113
A Genius of the Fair World	114
by E. R. Yarham		
New L.N.E.R. Coach	118
Why do Clocks Tick?	119
by T. R. Robinson, M.B.H.I.		
How Fibreglass Wool is Made	120
Facts about Steel—III	124
by Eric N. Simons		
Electric Light for L.N.E.R. Engines	129
Air News, 116. Books to Read, 123. Club and Branch News, 134. Competitions Page, 143. Fireside Fun, 144. From Our Readers, 135. H.R.C. Pages, 136-7. Meccano New Models, 132. Among the Model-builders, 130. Competition, 133. Photography, 128. Railway News, 126. Stamp Pages, 139, 141.		

Welding in Post-War Reconstruction

By C. W. Brett, M.Inst.W.
(Managing Director of Barimar Ltd.)

AS this war draws to its conclusion one hears more and more about winning the peace. The majority of those folk who are pressed to say just what they mean by a statement of this kind are likely to declare that it all depends upon the terms agreed at the peace table. True as this may be, so far as it goes, it ignores the fact that the responsibility for a successful transition from munitions of war to those of peace rests upon the shoulders of each one of us.

Think for a minute of the vast amount of planning implied, and the work involved to carry it out, with not a moment to spare from the instant the signal is given.

A few firms are fortunate. Some Diesel engine builders, for example, were producing in 1939 just what was required for wartime needs, and when official orders cease, commercial requirements will be met with virtually the same type of power unit. With the vast majority of firms the complete opposite is the case, and sometimes scarcely a machine at present in use can be included in the future programme, although a few may be utilised after suitable modification.

The task that lies ahead is sufficient to daunt the most courageous, and yet there are ways and means that are in danger of being neglected. What the position in this country would have been were it not for scientific welding is hard to imagine. It is the development of the welded ship which has allowed the building of a mercantile armada within record time, and this Allied fleet has proved invincible. The Naval authorities too speak in terms of the highest praise of ships that, in expert opinion, must have foundered had the strains imposed come upon riveted plates and angles instead of those that had been welded.

Others have been equally impressed by the wonderful work done in regard to the reconditioning of plant and machinery of

all kinds damaged by normal hazard or enemy action, but always needing dependable reconditioning with the least possible loss of time.

Therefore the feasibility of using similar means to rehabilitate and convert machinery of every description, so that new products can be turned out in large quantities in a matter of weeks or even days rather than after months of delay, is one that has received the closest attention of experts. Specialists pointed out that it is reasonable to make almost any factory machine in the welding shop. Instead of castings, fabricated steel plate can be used; while for forgings, such as

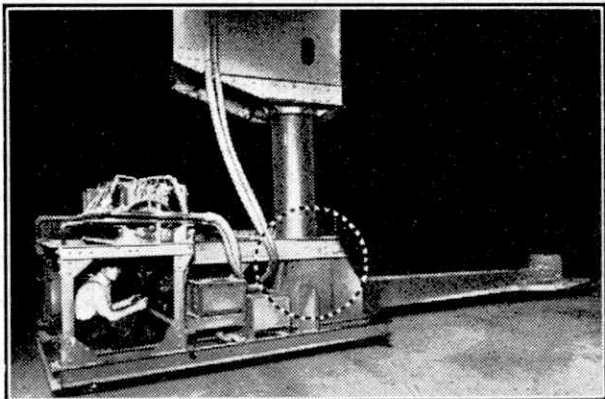

Fig. 1. Cracks in the portion of this crucible loading machine shown inside the dotted ring were repaired on "Barimar" mobile welding plant. The illustrations to this article are by courtesy of Barimar Ltd.

gear wheel blanks and far more complicated items, the cutting flame applied to billets can do all that is necessary.

It is not suggested that most machines will be produced in this way, at least in the immediate future, for castings are still the cheapest method of production where large quantities are concerned. But in cases where special units are required, or even two or three duplicate machines are needed, then welding scores in every respect, including cost, for the chief saving is in patterns which are avoided.

So accurate are gears and sprockets shaped by machine-operated flame that they need no final machining. In contrast

to this, great skill and experience is needed in regard to repair work, for it must pass the most stringent of tests, including X-ray examination, otherwise the work could hardly be guaranteed in the customary manner.

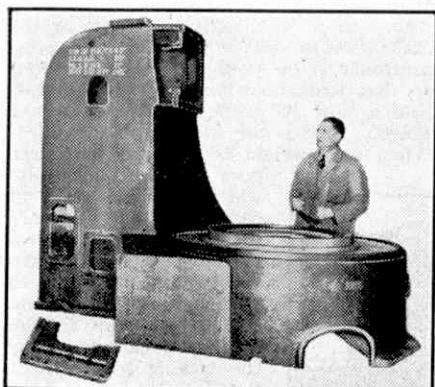

Fig. 2. This picture shows a damaged casting weighing over 6 tons, and in the picture below is seen the repair as completed in the Barimar Works by welding.

All sorts of cracked or broken metal components are made whole again, and machined to within split hair limits leaving no trace of repair. Worn shafts and a multitude of other items have new metal welded to the defective areas so that it becomes homogeneous with the parent material. In most instances increased resistance to further wear or corrosion results. This is not due to the welding solely, but also to the metal used, for the latter is chosen carefully with regard to the duty required.

Some idea of the enormous strength of this class of repair is indicated by the large number of engine crankshafts which are reunited after fracture. The majority of these belong to road vehicles, but there is a liberal sprinkling of large marine engine cranks. Recently this type of mechanical surgery was successfully carried out upon the crankshaft of a main line railway locomotive.

Already there are some who are planning to take over certain types of machinery to recondition and convert on the lines described. Not only will otherwise rejected plant be put into valuable circulation once more, but this scheme, apart from being profitable, will help to reduce the scarcity of suitable factory units.

A vast amount of experience has already been acquired in work of this kind, not

only on account of damage sustained, but also because of the vital necessity for maintaining in efficient service the many thousands of machines operating in this country that are of Continental origin. For this reason they have been cut off from all hope of assistance from the parent factory. Had it not been for the skill of scientific welding specialists who dealt promptly with broken, worn and corroded parts when replacements were out of the question, invaluable machinery would have stood idle or been scrapped at a time when it was most needed. Nothing of the kind happened, and by extending the same methods to meet the dissimilar problems of the vast task that lies ahead, an even greater triumph may be achieved.

Our pictures illustrate two extensive welding repairs. Fig. 1 shows a crucible loading machine that carries three tons of non-ferrous metal on its "tongue." The machine with its load is suspended from the round vertical column, which is drawn up until the loaded tongue is level with the furnace door. Then the operator, seated inside the cage, starts an electric motor, and the tongue and its load are run right into the crucible. The centre member cracked and the machine could not be operated. Obviously it was scarcely practicable to take it through the streets to the welding factory, so a welding workshop on a big lorry was taken to the job. To drive the welding machine was a powerful Diesel engine, and all the necessary tools were ready to hand. From start to finish. (Continued on page 142)

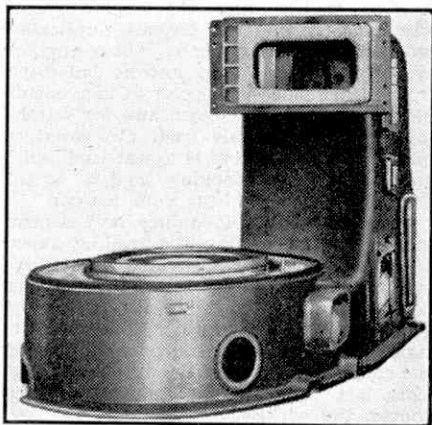

Fig. 3.

Driving a Diesel-Electric Locomotive

Thrills of the Shunting Yard

OUR cover this month shows the driver of a Southern Railway diesel-electric shunting locomotive in his cab. What does it feel like to be driving an engine of this kind? Come with me, climb into the cab and see for yourself.

First of all you will notice that this cab is totally enclosed, with windows at the front, side and back. It is much more

The engine ticks over with the familiar noise made by diesel-engined buses. Take your seat at the controls. There is the brake lever in front of you, and the master-controller is by your side. Put one foot on that loose floor-board under the seat. Notice how it springs down with your weight. That is the "dead-man's treadle."

When your weight is removed the brake goes on automatically, which is a safeguard in case you are suddenly taken ill and lose control of the engine in motion. However, if you want to change over from one side of the cab to the other you can do so, as the treadle has a short time-lag, long enough to allow you to change your position and depress a similar treadle on the other side.

On the panel above your head are gauges showing the air pressure, the oil pressure and the temperature of the engine.

By the way, the temperature of the engine has automatic control too, and as the temperature of the cooling water increases, the radiator fan speeds up to draw more air through the radiator.

Now try yourself out as a driver and push this train of wagons ahead of us. The shunter is waving you on. Release the brake, put the reverser lever to "Ahead" and move the controller handle to the first notch. Inside the engine compartment you hear the engine "rev up" at once, but otherwise you would hardly notice that we are moving. "Chink, chink," go the buffers of the wagons as we push them forward. Move the handle another notch to increase your speed, and notice how the control system automatically increases the diesel-engine speed in proportion to the load which you are pushing. Now "whoa"; the shunter has his arms above his head; return the controller to the "Off" position and apply the brake. Gently, though, or you will cause a snatch, and probably get bumped off your seat!

"Simple!" you say. Yes, the locomotive answers the controls (Continued on page 142)

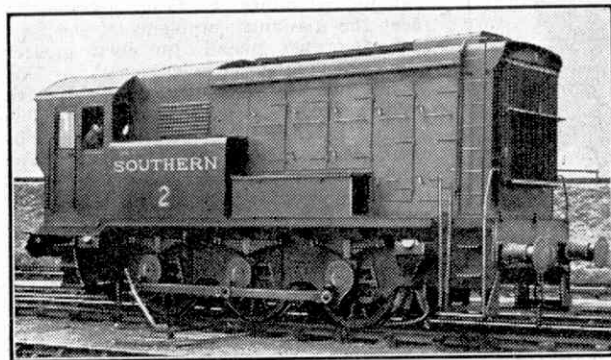

Southern Railway "English Electric" Diesel Locomotive.

comfortable than the steam engine we have just left, with its open, draughty footplate, and with coal dust blowing round your legs. The shape of the cab is roughly the same, but where the fire-box would be on a steam engine there is a door leading into the engine room. The controls, you will see, are duplicated on each side of the cab. These engines are driven by one man, and he can drive from either side, whichever is convenient for seeing ahead or astern and for watching the hand signals from the shunters on the ground. There is a seat each side, and that homely-looking gadget is an electric hotplate to heat your tea-can.

These 52-ton 0-6-0 engines have electric motors on the leading and trailing axles, and the current is provided by a six-cylinder, 350 h.p. diesel engine driving a large generator. There is also a smaller generator which charges the starter batteries and provides current for the lights, the control system and the air compressor. This last operates the brakes and, of course, the whistle.

To start the engine, press that button.

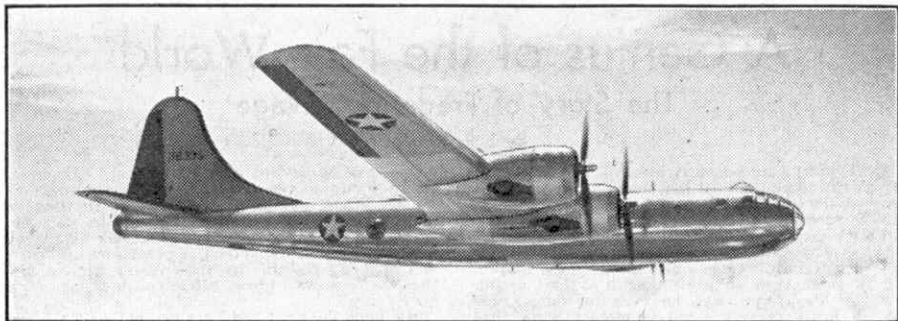

Photograph by courtesy of Boeing Aircraft Company, U.S.A.

The Boeing "Superfortress"

THE largest bomber in the world, the Boeing B-29 "Superfortress," is being used on an increasing scale by the U.S. 20th Air Force in carrying out raids upon Tokio and other Japanese military targets. This huge bomber is half as big again as the "Flying Fortress," and its gross weight is twice as much. Its wing span is 141.2 ft., length 98 ft., and height 27 ft., as compared with the B-17's span of 103 ft., length 75 ft., and height 19 ft. Each of the four Wright "Cyclone" engines of the "Superfortress" is rated at 2,200 h.p. for take-off, nearly twice the power of that of the engines fitted to the "Flying Fortress," and has two exhaust-driven turbo-superchargers.

As it stands on the airfield awaiting its crew the "Superfortress" looks a truly formidable aircraft of war. Its long cylindrical fuselage, with the extensive nose jutting close to the ground, is supported by a massive-looking tricycle undercarriage. The sinister appearance of the machine is increased, if anything, by the exceedingly long slender wing, and the oval engine nacelles with an enormous mouth-like duct on the face of each nacelle—the one duct takes the place of a quantity of them in the wing. The undercarriage is completely retractable. A double-wheeled nose wheel, the first ever built into an aircraft, is placed close under the "greenhouse," or plexiglass nose.

The wing has a huge set of wing flaps that take up nearly one-fifth of the wing area, and give the machine a landing speed in the same range as the "Flying Fortress," in spite of the fact that the B-29 is twice as heavy and much faster. The big flaps also give the machine astonishing take-off performance, and it can operate from normal-size runways. In appearance the dorsal fin of the tail unit resembles the smaller one of the B-17. In spite of its great size the tail can be handled by the pilot without the aid of a power boost.

The "Superfortress" is the first bomber to have two bomb bays. Together, they are designed to carry equal weights of large or small bombs, or a combination load. Bomb loads on an aircraft are always located as near the centre of the machine as possible so that the trim of the machine will not be affected when the bombs are released. Both of the B-29's bomb bays could not be located at the machine's centre of gravity, so one was placed forward of this point and the other aft. This meant that one bomb bay could not be emptied before the other without throwing the machine temporarily out of level flight. The Boeing engineers therefore designed a mechanism that drops a bomb alternately from one bay and then from the other, and in this way the centre of gravity can be maintained.

Three sections of the "Superfortress" fuselage—the pilot's control cabin in the nose, the gunner's compartment amidships, and the tail gunner's section—are pressurised when the bomber is flying at great heights, and therefore the crew do not have to wear oxygen masks. The armament of this heavily defended aircraft consists of power-operated turrets with multiple gun installations of .50 calibre machine-guns and a 20 mm. cannon. A remotely-controlled firing system is employed so that the gunners, in their pressurised compartments, can operate guns outside the compartments. The system is similar to that used on battleships and was developed jointly by the Boeing company, U.S.A.A.F. Material Command, and the General Electric company. The gunners are removed from any manual contact with their guns, and with the exception of the tail gunner, fire them from remote stations. The tail gunner is near his guns, but not in manual contact with them. Sighting accuracy is improved by this system, as with the gunner removed from his guns he is spared the jar and vibration of recoil, and it is easier for him to track his target and hold his sight on it, also he has to move only a small sight instead of swinging heavy guns. The gunners have comfortable seats and ample room to stretch and change position.

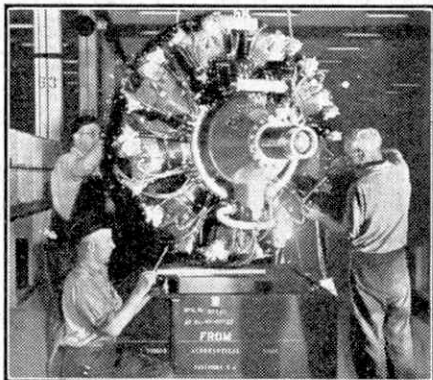

Assembling one of the 2,200 h.p. Wright "Cyclone" engines for a "Superfortress." Photograph by courtesy of Wright Aeronautical Corporation, U.S.A.

A Genius of the Fair World

The Story of Frederick Savage

By E. R. Yarham

ONCE upon a time country folk did their marketing at the nearest annual fair, and after it was done they abandoned themselves to cudgel playing, throwing at cocks, flying dragons, two-headed monsters, fat boys, soaped pigs and all the rest of the fascinating age-old attractions of the fairground, not forgetting Punch and Judy. These will return, for the English fair is more than an institution; it is part of our national life. These days, however, the fair engines are in many cases engaged in sterner work than whirling roundabouts. "Norah," "Princess," and "Demolitious," and "Illuminator" which was serving on the Western Front a quarter of a century ago, know every fairground in England, but they were

young men he devised a primitive "car." He fixed the body on four wheels, and the axles were revolved by side levers, worked by both hands. He used to come home at week-ends on it, and to visit his sweetheart, who lived in the adjoining village of Sloyley. Owing to its method of propulsion his "car" was dubbed "go-cart" by the country people, and thus the expression arose, "Here comes Savage with his go-cart."

His fame does not rest on that, but on his work for that great body of itinerants, the showmen of Great Britain. He was their cleverest engineer and benefactor, and the Showmen's Guild, formerly the United Kingdom Van Dwellers' Protection Society, which has done so much to raise the status of the profession and to protect its rights, owed more in its early years to Frederick Savage than to any other person.

In 1933 the Showmen's Guild paid commemorative honours to Savage during Lynn's Mart, as the town's fair is known, and these included a procession to his monument in the London Road, the only statue to a public man in the borough. It was fitting that such a tribute should be paid to this great engineer, who through his inventive genius applied steam power to the roundabouts and thus created an important industry.

Before the introduction of steam power, pleasure riding devices were very primitive, propelled by a pony or by manual power; and those engaged in the pushing were given a ride in repayment for their energy. Although these devices were not numerous they were well patronised, but because of their antiquated method of propulsion they could not make much of an appeal to the multitude. When Frederick Savage harnessed steam to the roundabout

he placed within the travelling showman's reach an invention that effected the most sweeping changes in the fair world since the Middle Ages.

The improvements did not stop at the roundabouts themselves, for decoration, illumination and music all made marked progress. Decoration consisted of highly gilded carved work; the smelly, smoky oil flare gave place to the electric lamp; and the creaking barrel organ was replaced by the powerful mechanical organ. In more recent years the use of electricity had led to further improvements. Such profound changes could not fail to have their effect upon the showmen themselves, and the proprietors of the fairs too. Often tens of thousands of pounds are invested in the elaborate apparatus of a modern fair, and the attendants must be skilled mechanics.

Frederick Savage, the man to whom this revolution is mainly due, was reared in as humble and unpromising circumstances as any of the showmen he so tremendously aided. He was born in a cottage at Hevingham, near Norwich, on 3rd March 1828. Of education he had little, and he was early sent cross-scaring on a neighbouring farm, taking home the princely sum of half a crown as wages for long tiring hours in the fields. He quickly showed his mettle by determining to leave home, which he did with all he possessed tied up in a small bundle on his back, when he was about 16 years old. At

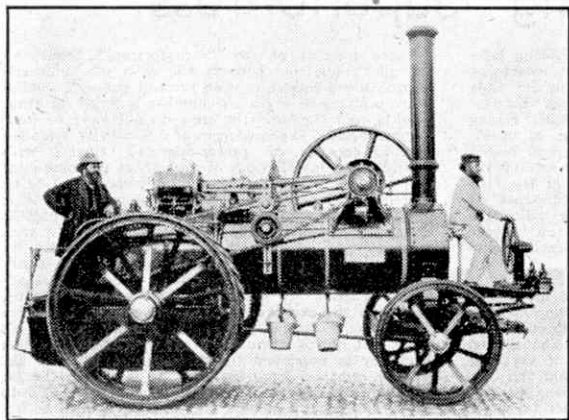

One of the earlier types of Savage traction engines, with Frederick Savage himself standing on the rear platform.

posted to London to pull down great walls that shook but refused to fall when the capital was assaulted from the air. Savages of King's Lynn, the birthplace of the roundabout in its many guises, and home of some of those engines, whose name is a household one in the amusement world throughout the Empire, have also had more urgent work of late to attend to than "all the fun of the fair." Ships must come first, and at this moment an engine stands forlornly in the yard of the firm waiting for the return to peace.

The story of Savages of Lynn is one of the most interesting, but at the same time most undeservedly forgotten chapters in the history of English engineering. Frederick Savage, 1828-1897, was an untutored mechanical genius who revolutionised the amusements of the mass of the people, and only by a mischance that has never been explained did he miss being the first builder of motor cars in England. Towards the end of his life, when his firm had achieved an international reputation, he was approached by American financiers with plans and patent rights for the manufacture of motor cars. Terms were arranged and a large factory was erected in the grounds of the firm for the production of cars, but for some unknown reason the project came to nothing.

Savage had been interested in mechanical propulsion from a lad. When leaving his village home as a

East Dereham he got work at Cooper's, afterwards Gill's foundry, as a rough carpenter, and was able to put a little money by. With this as his capital he moved on to King's Lynn about four years later.

In King's Lynn Savage joined the employ of Charles Willetts as a wheelwright and blacksmith. Willetts had a machine shop in Baker Lane, off High Street, and the young man showed such ingenuity, judgment and industry that when his master retired two years later he was able to set up a forge of his own in the Mermaid and Fountain Yard. He married on the strength of that success, and good fortune continued to follow him, particularly as he proved an unusually skilful mechanic. To begin with he made iron rakes, but soon he turned to something more ambitious. Up till that time farmers had flailed their corn to separate the grain from the husks. Savage devised a winnowing machine that had a hopper to receive the corn, and a fan to blow away the husks, which dropped into refuse bins, while the corn was fed into sacks. Though still hand operated it was the predecessor of the threshing machine.

The young engineer's business expanded so quickly that he required larger premises, and took part of an old workhouse. He stayed there six years and began building threshing machines and portable steam engines. Another move became necessary, and this time he established what became known as the St. Nicholas Iron Works, which stood near the Tuesday Market Place, so that he was in the heart of things. There he continued along the lines that he had begun, and opened up others, such as traction engines. His reputation as an agricultural engineer grew fast, and he gained further renown when he devised the first successful steam roundabout. His firm became the only one in the world making this and similar appliances.

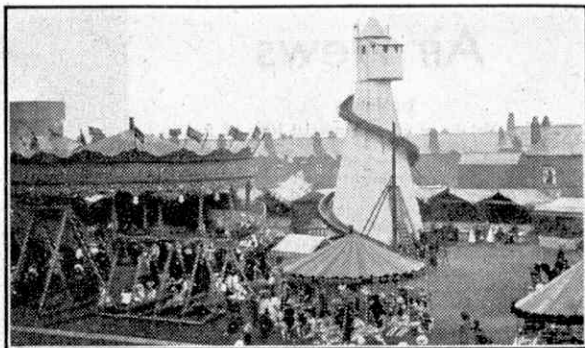

A Savage roundabout, driven by a steam engine, is shown in this fairground scene.

firm built up a great export trade in agricultural implements, steam ploughing tackle, threshing and dressing machines, elevators, etc. and show appliances, so that the names of Savage and King's Lynn became known throughout the world.

Savage took up the fair business as the result of his contact with showmen travelling with primitive hobby-horse machines and swing boats. He showed considerable skill in repairing these, and when one man consulted him about a certain improvement, he replied: "Yes, my boy, and I'll make you one driven by steam-power." He was as good as his word, and this first power roundabout gained such fame and popularity that he was soon asked to build others.

These early contrivances showed signs of being conversions from manual operation, but yet a few lingered on until right after the last war. The small centre-engine was separate from the main pole and was rather like a developed tar-boiler in appearance. Such portability as it possessed was provided by four fixed wheels, more of the order of castors, crudely attached to the boiler, the use of which was confined to manoeuvring to the centre from the truck in which the engine was carried. These roundabouts were built in the 70s and were followed by the more developed centre-engine.

The well-known circus proprietors, the Sangers, mentioned a device they had seen in Paris. Savage developed it into what was known as Sea-on-Land, boats being drawn round a circular track by horses, which were soon replaced by a traction engine in the centre of the ring. Later came the circular Switchback, embodying the principle of this ride, and the ingenious Switchback Gallopers, which consisted of horses galloping over a circular track. The Cake Walk was another invention, and the Tunnel Railway was a covered-in circular track forming a tunnel through which a miniature railway engine drew small carriages.

Frederick Savage's inventions marked a new epoch in the history of the show world, and he was honoured by engineering societies both at home and abroad. He found time to take a prominent part in the civic life of Lynn, and the untutored country lad's crowning honour was his mayoralty in 1889-90. His term was an extremely popular one, and at the end of it the statue in London Road was privately erected as an acknowledgment of his distinguished career.

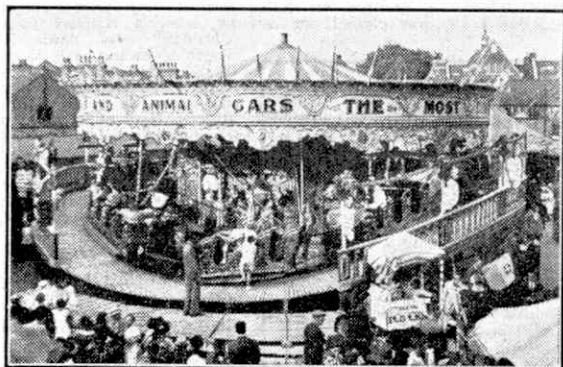

A fine example of a "spinning-top" steam switchback as built by Savage Brothers Ltd. This has been converted to electric drive and the cars are not the original, but it retains its old-world grandeur. Photograph reproduced by courtesy of Mr. P. W. Bradley.

The final move was to newly-established land north of the town, with excellent rail and water facilities. Six acres of land were taken over, and soon 300 to 500 men were employed. In conjunction with an Essex firm Savage patented the steam plough, an invention in which £100,000 was sunk, and the

Air News

Turbinlites

The first details of another special item of British night-fighting equipment—the "Turbinlite"—have just been released. The "Turbinlite"—a small but very powerful airborne searchlight—was first fitted in the nose of some Douglas "Havoc" I and II fighters and "Mosquitos" and "Wellingtons" in the dark days of 1941. With the exception of the "Wellingtons," the searchlight aircraft were unarmed, and were usually accompanied by a flight of three "Hurricanes" or "Defiants" which flew slightly above and behind, maintaining contact by means of lights in the top surface of the wing of the Turbinlite-carrier.

J.W.R.T.

Sikorsky Developments

The Sikorsky R-4B military helicopter is now being built in large numbers for the U.S.A.A.F. and the British Fleet Air Arm at Bridgeport, Connecticut, on the world's first helicopter production line. It will be used for general "spotting" duties with the Army and on anti-submarine patrol. The R-4B is powered by a 180 h.p. Warner "Super-Scarab" engine and promises to be quite useful, but, in its present form is rather tricky to fly. It can be fitted to carry a stretcher and has interchangeable wheel and float undercarriages. It is 35 ft. 8 in. long and has a rotor diameter of 38 ft.

As soon as United Aircraft have fulfilled their contract for the R-4B, they will turn the assembly line over to quantity production of the new R-5, which is a nicely-streamlined two-seat military model. It is powered by a 450 h.p. Pratt and Whitney "Wasp Junior" engine and is thus an entirely United Aircraft product. The R-5 has a rotor diameter of 46 ft., is 40 ft. 10 in. long and weighs 4,800 lbs. fully loaded.

The R-6, another two-seat military helicopter, has a 245 h.p. Franklin air-cooled engine, and will be built in large numbers by Nash-Kelvinator at Michigan under a license agreement with United Aircraft. It is bigger than the R-4B, and can carry two stretchers side by side when used as an air ambulance. J.W.R.T.



A Sikorsky XR-5 helicopter hovers a few feet above the ground. Photograph by courtesy of United Aircraft Corporation, U.S.A.

British Long-Distance Test Flights

The round-the-world flight by an Avro "Lancaster" from the Central Flying School, Flying Training Command, R.A.F., briefly reported in the December 1944 "Air News," has been completed. The purpose of the flight was to test the navigational efficiency of both crew and equipment under varied conditions.

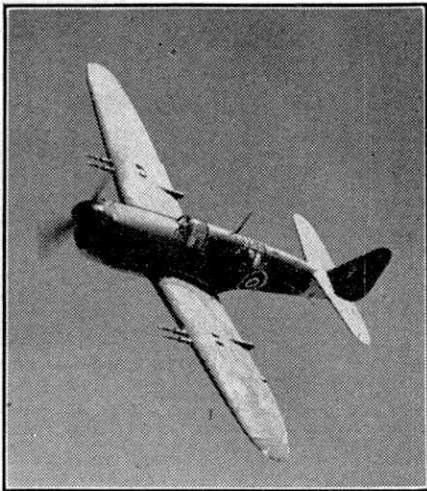

Fairley "Firefly," the first specially-designed cannon-armed British fleet fighter.

The aircraft was away from the base 53 days, 40 of which were spent in flying, and flew 41,454 miles. The outward trip took 71 hrs. 45 min., and the route followed was by way of Iceland to Montreal, on to Washington and San Francisco, and thence across the Pacific to Auckland, New Zealand, and finally to Melbourne and other Australian coastal places. The return trip began with a non-stop flight from Australia to Ceylon, accomplished in 15 hrs. 8 min., and from there was by way of Aden, Cairo and Malta. The weather encountered on this great flight ranged from icing conditions to tropical sunshine and storms.

Another interesting British long-distance flight was carried out recently, when a Handley Page

"Halifax" was flown to South Africa and back, about 12,000 miles, to test the engines and equipment under a variety of weather conditions. Much of the military equipment was removed from the machine, and many special recording instruments were installed, including air thermometers around the nose, and a temperature recorder to each of the cylinders of the four Bristol "Hercules" 14-cyl. engines.

The "Halifax" had more than 2,000 gall. of fuel on board when it took off on the first lap of its long journey, a 1,000 miles flight across France and Corsica to Naples, followed by one of 1,500 miles across the Mediterranean to Cairo that took only 7 hrs. Close

attention was paid to the behaviour of the engines during the next stage of the trip, from Cairo to Khartoum, and special taxiing trials were carried out at a sandy aerodrome in the desert. Later over 50 hrs. experimental flying was done near Asmara, which stands about 7,000 ft. above sea level. The subsequent return trip to England was uneventful.

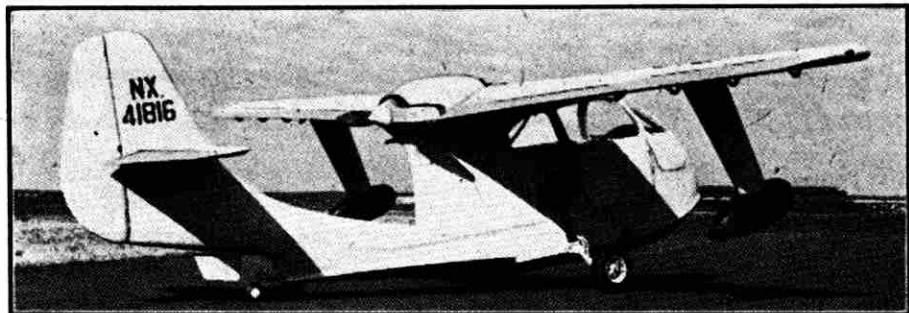

One of the first pictures of the recently designed Republic "Thunderbolt Amphibian." Photograph by courtesy of Republic Aviation Corporation, U.S.A.

The "Thunderbolt Amphibian"

The prototype of a 4-seat all-metal amphibian, intended for the post-war private-owner, has been completed by the Republic Aviation Corporation, U.S.A., and is shown in the above photograph. The new aircraft, which has been tentatively named "Thunderbolt Amphibian," is powered by a 175 h.p. six-cylinder horizontally-opposed engine, mounted at the rear of the cabin and driving a "pusher" propeller. This feature permits better forward view, reduces the risk of water spray damaging the engine, and facilitates soundproofing of the cabin.

The 36 ft. span wing is fully cantilever, with single-strutted floats, and the fuselage hull has been designed to permit take-off and landing, fully loaded, on only 17 in. of water. A retractable undercarriage is fitted, the tail wheel swivelling upwards to prevent interference with the water-rudder. At an all-up weight of 2,600 lbs. the "Thunderbolt Amphibian" has an endurance of five hours at 105 m.p.h. Republics hope to put it on the market at a cost of about £900. J.W.R.T.

The Latest "Wimpeys"

Although it seldom gets much publicity these days, the Vickers "Wellington"—the mainstay of Bomber Command in the early years of war—is still giving good service with Coastal Command as an anti-submarine patrol bomber. The latest versions that may be mentioned are the Marks XI and XII powered by two Bristol "Hercules" XVI engines and the Marks XIII and XIV which have 1,650 h.p. "Hercules" XVII's. These give a top speed of about 250 m.p.h.

These aircraft carry a great deal of specialised equipment to assist in locating and destroying the elusive U-boats, and photographs show them covered with a variety of "Christmas-tree" aerials. In addition the Mk. XIV carries a Leigh Light searchlight in its nose, which is fitted with a special "chin." This installation is very much neater than that on the R.A.F. "Liberator" V, which carries its searchlight under the wing. Armament of the Mk. XIV comprises a four gun tail turret and one beam gun on each side of the fuselage aft of the wing. Over two tons of bombs, mines

or depth charges may be carried. The "Wellington" XIII is basically similar to the Mk. XIV but has no Leigh Light. Instead a standard two-gun nose turret is fitted. J.W.R.T.

Douglas Instructional Schools

The Douglas Aircraft Company, U.S.A., is now producing mobile instructional units as well as aeroplanes, to teach U.S.A.A.F. ground staff in all theatres of war how to keep Douglas warplanes and transports 100 per cent. serviceable. Twenty-five schools have already been despatched to bases all over the world, from France and England to tiny Pacific islands, wherever the company's "Skymasters," "Invaders" and "Dakotas" are flying. Others are being built for use at American training stations.

Each school is staffed by seven to ten Army instructors and a Douglas Service representative, and includes about a score of compact demonstration models of such things as fuel, electrical and hydraulic systems, flying controls, instruments and various secret devices. The equipment can be easily transported by lorry or plane to forward airfields, and no less than eighteen units are now stationed in France, Italy, Britain and America to give instruction in the maintenance of the new "Invader" attack-bomber. Other schools are training crews to service the giant four-engined C-54 "Skymaster" transports. One travels by air regularly from Honolulu to South-West Pacific bases, and "Dakota" units are operating in India and Australia. J.W.R.T.

The Curtiss SC-1 seaplane in service with the U.S. Navy has been given the type name "Seahawk."

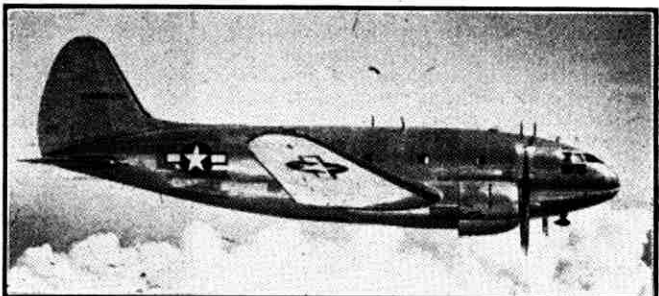

Curtiss "Commandos" for the U.S. Army Air Forces now go into service in their natural aluminium finish, and one of these twin-engined transports is shown here without camouflage. Photograph by courtesy of Curtiss-Wright Corporation, U.S.A.

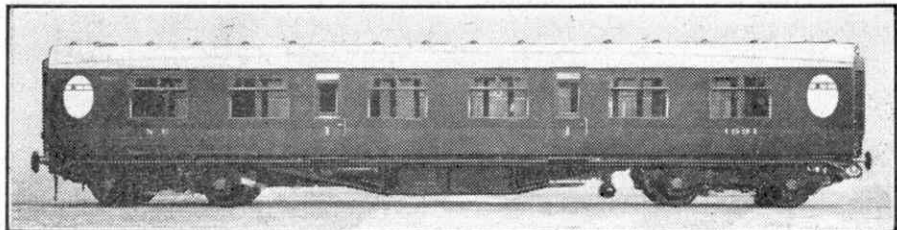

The compartment side of the new L.N.E.R. standard 1st class corridor coach described in this article.

A New L.N.E.R. Coach

Standard Layout for Post-War Travel

THE L.N.E.R. has just completed and put into traffic a 1st class corridor coach of steel and timber composite construction that has a new layout, and this is to be standard for future vestibuled corridor stock. The new layout has been adopted at the suggestion of Sir Charles Newton, the company's Chief General Manager. It divides the coach into three sections of two compartments each by means of two passages across the coach, each connecting a pair of opposite entrance doors.

This arrangement has many advantages over that of the customary corridor coach with doors at the end. To begin with, the average distance between door and seat is very much reduced, and except in the case of the compartments at each end of the coach the movement between door and seat may be made without passing another compartment; to reach the end compartments only one other compartment has to be passed. Then the transverse passages provide convenient passing places for travellers proceeding along the corridor in opposite directions. Further, congestion on the platforms is reduced when passengers are entering and alighting from a train of such coaches, especially so as the doors are well spaced along it. To sum up, the new coach layout makes the entry, exit and inside movement of passengers much easier, and it gives them greater privacy at all times.

The new coach contains six compartments, each measuring 7 ft. 6 in. between partitions, and accommodates 36 passengers. The view from the compartments has been greatly improved in two ways. In the first place the outside windows

are 3 in. deeper and 6 in. wider than the previous standard, and the sill is lowered to 29 in. from the floor. In addition, on the corridor side the pillars between the outside windows are now placed opposite the partitions dividing the compartments, so that passengers are given an unobstructed view across the corridor. Ventilation is provided by sliding shutter type ventilators that are fitted in each compartment and in two of the corridor windows.

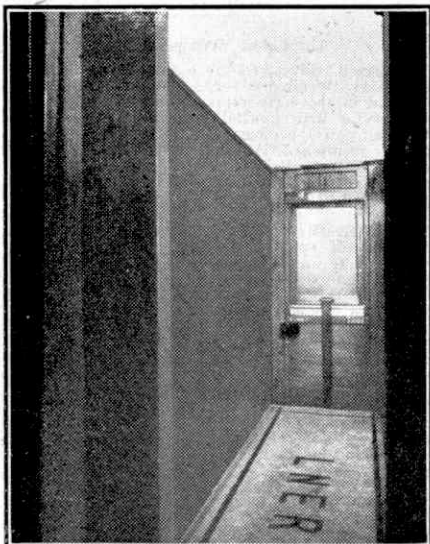

One of the two transverse passages in the new standard coach. Our illustrations are reproduced by courtesy of the L.N.E.R.

Have You Ever Thought About This?

Why Do Clocks Tick?

By T. R. Robinson, M.B.H.I.

THE ticking of a clock is probably the most familiar mechanical noise in the world, but, although it is so frequently heard by nearly everyone, few people can say what actually causes the friendly sound we know so well. To understand why a clock ticks, we must find out how a clock works, but this is not a very difficult thing to do, for clocks are really quite simple machines.

Before we look at the clocks themselves, we must think about time, and the way it is measured. Day, night, and the changing seasons remind us of the passing of time, but time itself cannot be measured directly, like a ton of steel or a mile of road. The best way to overcome this difficulty is to take some kind of work which is done at an even and regular speed, and to make the amount of work done in any interval a measure of the time which has elapsed.

In clocks, this is done by using some means of storing power, such as a weight or spring, and coupling this to a series of toothed wheels and pinions whose purpose is to divide up and transmit the stored energy to a governing and controlling device that will release it regularly and evenly, and so cause the wheels to rotate a definite number of turns in a certain period of time. The governing mechanism is called an escapement, and it works by releasing the power transmitted by the wheelwork in a series of even "doses," each representing the passing of a proportional time interval.

As its name suggests, the escapement acts by allowing an "escape-wheel" to move forward, or escape, a distance of half a tooth space at a time; the construction of the mechanism is so arranged that this action is controlled by a counting or regulating device, which is either a pendulum or a balance and balance spring. With a pendulum, the time each swing takes depends on its length, or, in scientific language, on the distance between its centres of suspension and oscillation. The time a balance takes to make each swing depends on its weight, and on the strength of the balance spring. The important thing is that the time of swing of pendulums and balances is "isochronous"; that is, that whether they swing in long or short arcs, their journeys are always completed in the same time. This makes it possible to use them to control our clocks, for even if they swing a little more or a little less they will still count time evenly.

If the swinging pendulum or balance is coupled to the escape wheel, so that each swing allows the wheel to advance one step, the wheelwork of the clock will move steadily forward, and if the swings are timed at the correct speed, hands attached to the wheel spindles will tell the time. This coupling of the pendulum or balance to the wheels is done by the pallets, and it is their action on the escape-wheel which causes the ticking of a clock. As escapements controlled by pendulums are simplest,

we will use them to explain the way in which the tick is produced.

The pallets are two accurately shaped parts, made of hardened steel, so formed that they can engage in turn with the teeth of the escape-wheel, which are also of special shape. The pallets are mounted on a spindle or arbor, pivoted in the clock frames, and also mounted on this arbor is an arm, called a crutch, with a forked end that links the pallets and pendulum and makes them move together. As the arbor is moved on its pivots by the swinging pendulum, one pallet advances to a point where it engages with and locks a tooth on the escape-wheel by moving into the path of the teeth. At the same time, the other pallet recedes, gradually releasing another escape-wheel tooth which is already resting upon it.

The spacing of the pallets in relation to the wheel teeth is such that when one pallet is in contact with a tooth, the other is opposite the space between two teeth; so as each pallet in turn advances and recedes, the receding pallet allows the forward movement of the escape-wheel until the tooth which is approaching the other pallet, the advancing one, moves far enough to rest upon it. The pendulum then swings back, reversing the motion of the pallets, and the tooth which has been resting on the advanced pallet is unlocked and permitted to move forward as this pallet now recedes. This action is repeated each time the pendulum swings, and the escape wheel moves forward at a governed speed as its teeth engage and disengage with the pallets.

We still have to explain the ticking, but we can do so now. The pallets have a double purpose, for, in addition to enabling the pendulum to control the clock, they also keep the pendulum swinging by transmitting to it enough energy to make up for losses it swings. This energy comes from the clock, and is called the impulse. To enable it to be transmitted, the pallet surfaces over which the escape-wheel teeth move as they are released are of inclined form. In travelling across these inclined faces, the teeth give a gentle push to the pallets, and this transmitted by the crutch keeps the pendulum swinging.

Now we come to the ticking. If it were possible for each pallet to control each escape-wheel tooth which rests upon it until the opposite pallet engaged with its next tooth, the escapement would act almost silently. But then the tips of the teeth would have no freedom, and this lack of clearance would cause them to catch the pallets. This is overcome by allowing the escape-wheel to make a slight forward movement between the point where one tooth drops off a pallet and the other tooth engages with the opposite pallet. This movement brings the tip of the tooth clear of the

(Continued on page 142)

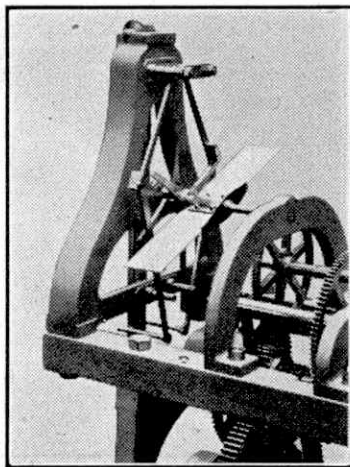

The Gravity Escapement, with "double three-legged" escape-wheel, two weighted gravity arms, and air-brake fan. Photo. courtesy of Gillet and Johnstone Ltd.

HOW THINGS ARE MADE:

Fibreglass Wool

Shimmering Silk from Molten Glass

IT is difficult to visualise a heap of sand being transformed into shimmering silk gowns for modern brides or gorgeous stage drapings for a West End theatre. Such a transformation is rather suggestive of a modern Aladdin's lamp or a twentieth-century Cinderella, but it is actually one of the many possibilities of a most interesting process of converting sand and other ingredients into very fine fibres, known as Fibreglass, that is carried out at the works of Fibreglass Ltd., Glasgow.

Fibreglass "wool" looks very much like cotton wool, and it possesses certain natural characteristics that make it particularly suitable for a wide variety of uses. It has been in use for a number of years in many industries. One of these is the motor industry, where it is used principally as a sound-absorbing packing for motor car silencers. During the war urgent demands have resulted in a wide extension of its applications.

All Fibreglass materials are an excellent insulator against electricity, heat and sound, and they are available in various forms according to the purpose for which they are intended. Glass wool can be made into what are known as blankets or quilts, by spraying it with a binding solution and then stitching it between sheets of fine cloth. These quilts are excellent for wrapping around steam boilers and pipes to prevent loss of heat by radiation. For lagging pipes it is also available in the form of shaped rigid or flexible sections, as shown in the lower illustration on the opposite page. Packed between the ceiling and walls of a room, Fibreglass wool will render the room almost completely soundproof, in addition to keeping it warm in winter and cool in summer. It has been used for this purpose in two experimental post-war

houses built by the Government at Northolt.

The first stage in manufacturing glass wool consists in loading the raw materials into small electric platinum furnaces. The chambers are about 3 ft. long and are shaped like shallow troughs. The walls of the furnace are lined with firebrick, and at the bottom there are rows of very small holes. When the glass is melted it pours through the holes in the plate and forms blobs that gradually break away

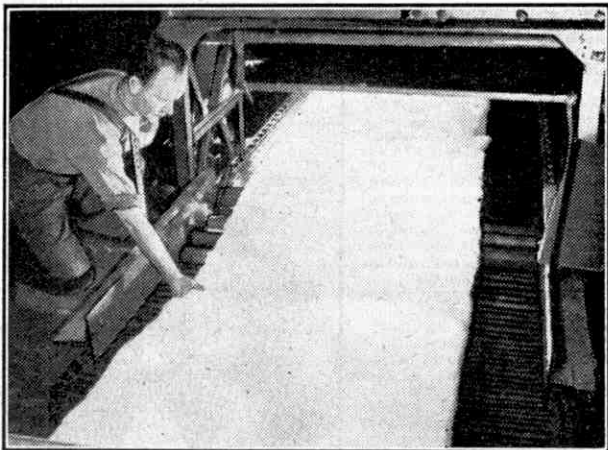

A general view of Fibreglass wool on the conveyor belt after it leaves the hood or canopy down which it falls after being made.

and fall, drawing a fine thread of glass after them. Readers will be familiar with what happens when treacle or syrup is allowed to fall from a spoon. First of all it forms a small blob, which gradually gets larger and heavier, until finally it breaks away, and in falling draws an extremely fine thread of treacle after it. This is exactly what happens in the case of molten glass.

The threads of glass fall a distance of many feet and drop on to a moving conveyor belt, on which they form a white frothy layer that looks like cotton wool and feels like fleecy eiderdown. This is called Fibreglass wool. The threads are

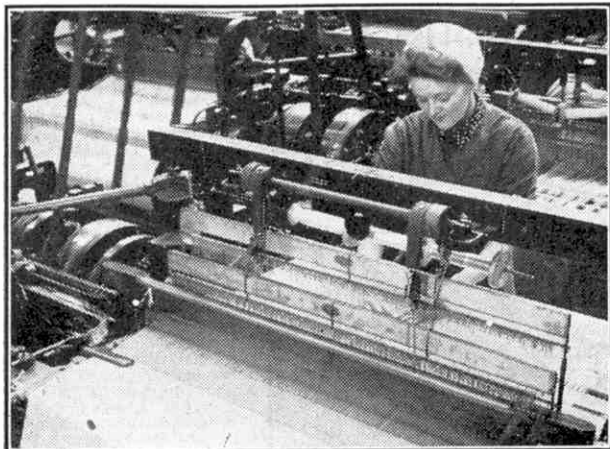

A view of a cloth loom weaving Fibreglass threads into shimmering silky textile.

not continuous, but fall in lengths of from 8 to 15 inches, and are so fine that five or six of them together are required to equal the thickness of a human hair. Yet they are stronger than steel of the same diameter. From every pound of glass it is possible to produce about 175 miles of thread.

In another arrangement a revolving drum takes the place of the conveyor belt. As the threads reach the drum they are wound around it. Thus continuous Fibreglass yarn, and also staple yarn, are produced.

Fibreglass is prepared for use in different forms according to the purpose for which it is intended. As already mentioned the material is a very efficient electrical insulator, and when woven into tape it is used for covering electric cables. Tape of greater thickness and of slightly different composition forms a most useful lamp wick, which never wears out or carbonises. At present the Armed Forces are absorbing the entire output of these glass wicks, but after the war they will be available for civilian use.

The glass tape and wicks are produced in the textile branch of the factory, which is equipped with special looms that weave the Fibreglass threads into tapes and ribbons up to one inch in width. Other looms

make glass cloth in widths up to 62 inches. One of the looms in operation is seen in the upper illustration on this page. By using suitably coloured glass, cloth can be produced in fascinatingly beautiful shimmering colours.

Another interesting application for Fibreglass is for making brushes for dealing with caustics and acids used in industrial processes, which would eat away an ordinary hair brush.

When sandwiched between sheets of plate glass, Fibreglass provides windows which keep in warmth and deaden noise while allowing diffused

light to enter. It is used also as a filter for air, and plays a very important part in the ventilation and air-treatment equipment of many modern buildings such as hospitals, air raid shelters, offices and theatres. The filter medium consists of a mass of criss-crossed Fibreglass fibres uniformly distributed and bonded into a mat or pad. The fibres are coated with a special adhesive chemical, which does not evaporate during the life of the filter. The coated pack is then placed between two metal grilles, and the whole unit is enclosed in a strong frame. This complete filter forms an easily replaceable unit.

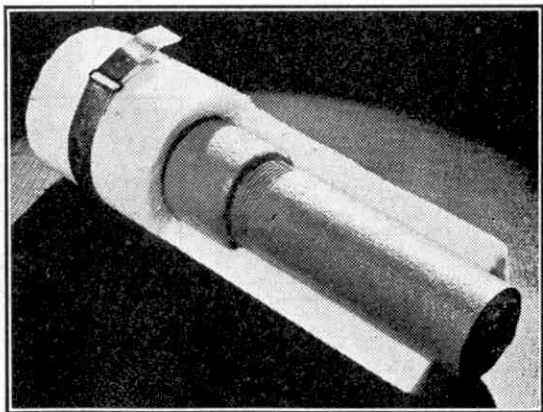

An example of Fibreglass wool used for lagging steam pipes. This picture shows how a rigid section of Fibreglass can be shaped to fit snugly around a junction between two lengths of piping.

Engineering Notes

New Dam Protected Against Earthquakes

On the Santa Eulalia River, about 50 miles east of Lima, Peru, a great dam is being constructed, and one of its most interesting features is that it is designed to withstand earthquake shocks. The structure is sited at a point where the river flows through a crack in the mountains caused by an

building and repairing locomotives and rolling stock for the L.M.S. lines.

At the outbreak of war in 1939 the L.M.S. had already begun production of wings for Hawker "Hurricanes." Since then the works have turned out wings for "Typhoons" and "Horsa" gliders and have repaired hundreds of planes damaged in combat. The very intricate and specialised work of making gun mountings has also been successfully tackled, and 250 17-pounder guns, and 500 carriages for 25-pounder field guns have been built. Other gun work included the renovation of 23 last war 12 in. howitzers, 51 carriages and limbers for 9.2 howitzer bodies, the manufacture of 13,000 gun and aperture sights for American Lewis guns, and many thousands of rifle butts.

For the Navy L.M.S. workshops have produced among other items over 8,000 assault boats and 2,000 shields of bullet proof steel for protection from low-flying aircraft.

During the dark days of Dunkirk nearly 700 tradesmen's motor vans were converted at great speed into armoured vehicles known as Armadillos, which were intended for the protection of airfields in the event of enemy landings in this country. During the first three years of the war the workshops turned out 642 tanks, comprising Centaurs, Matildas, Cruisers and Covenanters, and also provided thousands of spare parts for each type. Shell machining and cartridge case reforming have also been carried out extensively.

War Vehicles Shipped in Parts Across the Atlantic

Since the war started 300,000 American and Canadian vehicles have been shipped across the Atlantic in millions of parts and assembled by men of the British, Canadian, and United States Forces. The work was begun in 1940 by the Mechanisation Branch of the Ministry of Supply, and by May of last year 39 plants employing 100,000 workers were involved in the task. Maximum weekly output of 6,537 assembled vehicles was reached in April 1944.

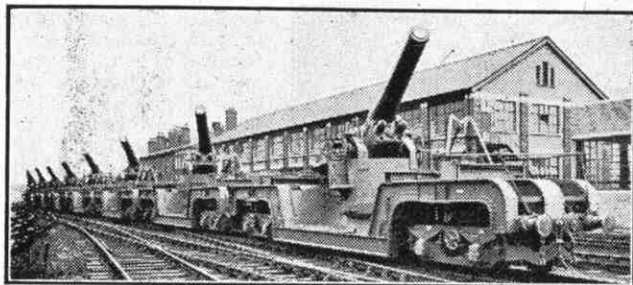

One of the many wartime activities of L.M.S. workshops. Rail-mounted 12 in. howitzers leaving one of the works after renovation. This photograph and that below are reproduced from "Carry On," by courtesy of L.M.S.R.

earthquake. The chasm is about 1,300 ft. long, 500 ft. deep, and from 18 ft. to 65 ft. wide, and the dam is being built on a solid concrete base that reaches down to solid rock 55 ft. below the bed of the stream and up between the walls of the chasm to a height of 90 ft.

The structure will be known as the Autisha Dam, and in shape is rather like a butterfly, with the wing sections separated by a space 6 in. wide and 10 ft. long. The manner in which this space is closed is the key point in the design, and in the event of an earthquake occurring in the area, it will permit the two wing sections to move without cracking. On the upstream side of the dam the gap between the wings is blocked by a length of iron pipe filled with concrete, which rests against two vertical beams set in the face of the dam and will be forced into the gap by the pressure of the impounded water behind it. At the centre of the 10 ft. gap is a shaft, on the downstream side of which is a V-shaped copper expansion joint that closes the space between the two wing sections on that side. The purpose of this flexible sheath is to prevent the passage of any water that may seep past the concrete pipe.

The work is being done in two stages. When the first is completed the dam will rise 256 ft. above the river bed and will hold back behind it about 396,300,000 gallons of water. It is expected, however, that the demand for water will steadily increase, and provision has been made for the height of the dam to be increased by 72 ft., which will create a total storage capacity of 2,377,530,000 gallons. The water under a head of 915 ft. will be used to drive an electric power plant to develop 30,000 kW.

How the L.M.S. Workshops Went to War

It was revealed recently that 44,000 workers in L.M.S. Railway workshops have been building tanks, guns, aeroplanes and other war equipment, in addition to carrying on their normal work of

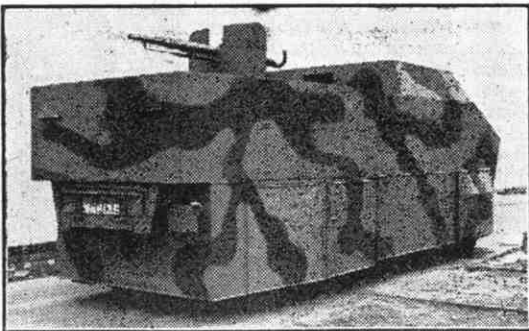

One of the Armadillos referred to on this page. It is one of 677 made in L.M.S. workshops at the time of Dunkirk.

BOOKS TO READ

Here we review books of interest and of use to readers of the "M.M." With the exception of those issued by the Scientific and Children's Book Clubs, which are available only to members, and certain others that will be indicated, these should be ordered through a bookseller. We can supply copies to readers who are unable to place orders in this manner. Order from Book Department, Meccano Ltd., Binns Road, Liverpool 13, adding 6d. for postage.

"MAN WITH WINGS"

By JOSEPH COTTLER (Harrap. 10/6 net)

The "man with wings" is Leonardo da Vinci, who devoted much of his time to designing machines that would fly. Leonardo lived nearly 500 years ago. Ever since that time he has been known as one of the world's greatest painters, but this was only a part of his life, for we know now that he was also an architect, an anatomist, an engineer skilled in military science, and an inventor, and that he was more interested in these pursuits than in painting. He was a legendary figure for centuries, believed to have been a dabbler in the black arts; but the extent of his interests was only revealed when pages of old manuscripts stored for 300 years or so in various libraries were deciphered. These were his

notebooks, written characteristically from right to left instead of in the usual way, and they were full of descriptions and drawings of an amazing range of contrivances, among them what we should now describe as tanks and submarines, roller bearings, brakes and gears. His aeroplane was only one of some 300 machines that he designed, the one to which he gave most thought. Studies of birds in flight and various designs in his sketchbooks show that the idea of flying was almost always in his mind, but it is uncertain whether in the end he ever made any practical trial of the schemes that he worked out.

"M.M." readers will be delighted with Mr. Cottler's story. This is not a dry collection of events and their dates. Instead we get a picture of the times in which Leonardo lived, and we see him moving through them from place to place, exasperating his employers by pursuing his dreams when they wished him to concentrate on particular tasks, and delighting them by the skill, inventiveness and energy with which he carried out these tasks when he did apply himself to them. We start with him as a pupil in Florence who showed more originality and thoughtfulness than any other would-be painter who studied with the same master. Then we follow him to Milan, where he entered the service of the reigning duke, for whom he acted as military engineer as well as painter, sculptor and architect. In the troubled politics of the time the duke eventually came to grief at the hands of the invading French, but French kings and Italian rulers alike greeted Leonardo with enthusiasm, eager to make use of his amazing knowledge; and it was in France that he died, after revising the 5,000 or so pages of the notebooks that he had laboriously filled with details of his inventions.

The story is one that will be enjoyed by grown-up people as well as the younger readers of the "M.M." All will wonder at the inventiveness and the resource of this great man, who lived long before his time. To his own world he was a dreamer, but it is easy to see that he was in fact intensely practical, and there is no doubt that many of the surprisingly modern machines that he designed did not become realities in his own lifetime only because of the universal lack of engineering craft and the absence of power. The book is well illustrated by reproductions of Leonardo's paintings, sketches and designs from his notebooks and pictures of models of his inventions.

"THE ISLE OF MAN RAILWAY"

By IAN MACNAB
(Greenlake Publications Ltd. 7/6)

We have to begin our review of "The Isle of Man Railway" on a sad note, as the first announcement of this most attractive publication unfortunately almost coincided with the news of the sudden death of the author. Ian Macnab was a member of the Signal and Telegraph Staff of the S.R., and a thorough enthusiast on the subject of railways both real and model. Readers will be particularly interested to learn that for a short period he was a member of the staff of the "M.M." One of his very special interests was the narrow gauge railway system of the Isle of Man, and the present book displays his deep and comprehensive knowledge of the history, development, equipment and operation of the Islands' railway.

The stories of the Isle of Man and the Manx Northern lines, the original two railways of the island, is entertainingly told in the first chapter. Then follows an account of the united concern produced by their fusion. Further chapters deal with train working,

signalling and single-line operation, with which of course the author was thoroughly "at home." Locomotives and rolling stock receive their due share of attention, and the remarkably complete nature of the company's plant is shown by the account of its works at Douglas. The descriptive matter covers also the developments of the past 20 years, including such activities as the associated motor bus services, and looks forward to the post-war reconstruction programme.

Excellent photographs illustrate the book, and these include examples of practically all items of the company's equipment, while many clearly indicate the picturesque nature of the districts served. In addition there is an excellent map, a mileage table and gradient profile, as well as extremely clear line elevations of various locomotives, carriages and wagons. There are two particularly attractive reproductions from water colours showing trains in the respective liveries of the present day concern and of the original Manx Northern line.

In short the book is a complete compendium of information on the Island railway system.

"WHEN SHAKESPEARE LIVED IN SOUTHWARK"

By E. K. SETH-SMITH (Harrap. 6/- net)

Mr. Seth-Smith's story has a double interest. The adventures told in it of Miles Francis, a London boy, and his strange companion, the son of the playwright Christopher Marlowe, are absorbing. We see the two boys first in the streets of London, and then in the country, to which they go as members of a touring theatrical company. They fall among thieves, and are even trained to become members of the gang, and there are many other strange happenings before they return home. With their story goes a picture of the England of Shakespeare's day, the scene being laid partly in London, with its churches, pleasure grounds and theatres, and partly in the countryside, where we see a stately mansion during a King's visit as well as the haunts of vagabonds and thieves. A pleasant story with excellent illustrations.

Owing to wartime difficulties, it is impossible to guarantee prompt delivery of books ordered as described at the head of this page, but every effort will be made to ensure speedy despatch.

Facts about Steel—III

Stainless and Heat-Resisting Steels

By Eric N. Simons

SOME thirty-odd years ago, a celebrated Sheffield metallurgist, Mr. Harry Brearley, observed a pile of scrap steel in the yard of the works with which he was connected. He noticed that while much of the metal was covered with the usual red rust that steel takes on when exposed to the atmosphere in the open, some of it did not appear to have rusted at all. His inquiring mind led him to investigate, and he discovered that, in every instance, the steel that had not rusted contained a high percentage of chromium and he was naturally led to the conclusion that chromium was an alloying metal that could give to steel the ability to resist corrosion.

This was the beginning of the stainless steel that is one of the most important materials in our modern civilisation. It is used for table knives, which do not now have to be cleaned and polished after use; for parts of seaplanes and aircraft, for shop fronts, pump spindles, valves, chemical storage tanks, road studs, ship's fittings, the lining of refrigerating holds on cargo ships, and a thousand other purposes. But since Brearley discovered that a high chromium steel resisted rusting, stainless steels have developed and multiplied until there are now available for modern designers, engineers, and architects, a wide range of different corrosion and heat resisting steels capable of fulfilling almost all the demands of industry.

The first stainless steel contained about 13 to 14 per cent. of chromium, and was principally used for cutlery. I will not re-enter into the argument carried on in these columns some time ago as to the ability of stainless steel knives to retain their cutting edge. I maintained then, and still maintain, that a stainless steel knife is, and can be kept, as sharp as any other knife, so long as it is regularly sharpened.

The next stage in the development of the stainless steels was the production of a stainless metal that would not only resist rust and corrosion, but also could be made malleable, so that parts could be pressed, forged or stamped from it. The original high chromium cutlery stainless steel could not be pressed or stamped; it was too hard, and lacked malleability. The solution was found to be a reduction in the carbon percentage of the steel, and this enabled the chromium percentage to be correspondingly reduced. Thus a range of what were termed "stainless irons" was produced capable of withstanding the attack of many acids and ordinary atmospheric conditions, but applicable to a much wider variety of parts and purposes than the first stainless material discovered.

The metallurgists by this time had perceived that they were on the track of a revolutionary discovery, and they promptly began to experiment by trying the effect of adding percentages of different alloy metals to the composition of the stainless steel, to

see if they could find even better steels. Nickel, silicon, molybdenum, titanium, tungsten, niobium, silver, bismuth, and many other elements were tried, and as a result a rapid multiplication of compositions ensued.

In general, however, modern practice concentrates on three separate classes of stainless steels; (a) the "straight" chromium steels, or chromium steels containing no other special alloy; (b) a series of stainless malleable steels with a basic composition of 18 per cent. chromium, 8 per cent. nickel; and (c) a series of chromium-containing heat-resisting steels designed for use at high temperatures.

Before we go further into this subject, however,

the reader ought to know something about corrosion and its cause. One of the first things we learn about iron and steel is that they rust. Rusty iron is merely iron that has undergone a form of corrosion, and the rust itself is what chemists term a hydrated oxide of iron, that is iron oxide containing a certain amount of combined water.

One would imagine at first that rusting would take place most readily on those parts directly in contact with oxygen and water or water vapour. Rusting may, however, occur more readily at points least accessible to oxygen. To understand this it is necessary to know something of the theory by which this fact is explained.

The modern electro-chemical theory of corrosion considers that corrosion or rusting is both an electrical and a chemical process, known as "electrolysis." When certain substances, such as acids and salts, are dissolved in water, the molecules of which they are composed are split up, or partly so, into negatively and positively charged particles known as ions. Because these ions are electrically charged, the solution will conduct electricity, and therefore the solution is known as an

"electrolyte."

Suppose we pass an electric current through this solution. The ions are immediately marshalled into two groups. The negatively charged ions are driven towards one pole, the positive and the positively charged ions travel to the negative pole. (These poles are only the plates or points at which the electric current enters the solution). At the positive pole the ions give up their electricity, and the ions at the negative pole are set free as separate elements. If the element is a gas, it comes away as such. If a metal, it is deposited as a film or coating on the negative pole, or "cathode," as it is called.

Thus, if we begin with a solution of very much diluted sulphuric acid, the effect of passing an electric current through it is to decompose the water of the solution into hydrogen and oxygen, its original constituents.

When iron and steel rust, a similar state of affairs exists. Here the electrolyte or solution is water

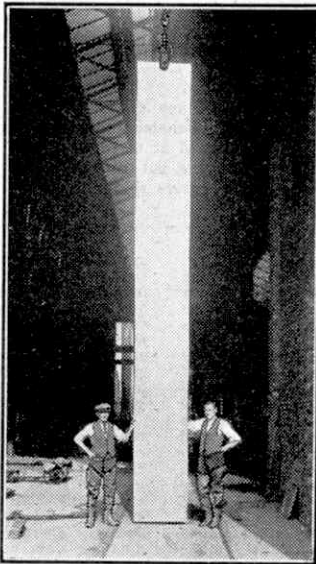

A large stainless steel plate.

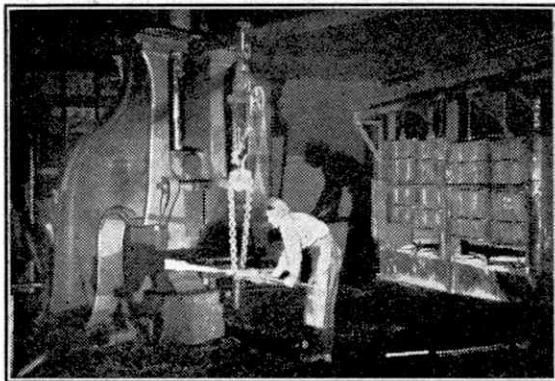

Forging stainless steel.

containing dissolved salts, or condensed moisture, which always contains carbonic acid gas, or even, as in Sheffield, sulphurous acid gases dissolved from the atmosphere. Most air at the seaside contains also particles of salt. In contact with impure water or condensed water vapour, some crystals of iron and steel act as poles to others, an electric current passes through the solution from one such pole to another, and decomposition or eating away of the crystals occurs. This is corrosion. It should be noted—(a), that if we pass an electric current through a solution, chemical action takes place; and (b), that if chemical action occurs in a solution, an electric current is developed. It is the acids in the water or water vapour that cause the chemical action, which, in turn, develops the electric current, which again causes the corrosion of the metallic crystals.

Why, we now must ask, does the presence of chromium in high percentages in a steel or iron prevent this corrosion from occurring? To answer this we must note that if a piece of iron is dipped in concentrated nitric acid, or certain acids containing chromium, it is not very greatly corroded. If afterwards plunged into a different acid it does not corrode to any appreciable extent.

The reason is that the first effect of immersion in nitric or chromic acid is for a film of oxide to be formed on the surface of the metal. This film is so close, thin and tenacious, that it acts as a shield, preventing the acid from working on the next metallic layers under the film. It is what is termed a "passive, protective film." Chromium is even more resistant to nitric acid attack than iron, so that any metal in which it occurs in high percentages will, when subjected to this form of attack, create an even more resistant passive film. This, however, is not the sole explanation. The steel must contain at least 11.0 per cent. of chromium, because only then do certain structural changes take place in it that make the grains or crystals of the steel *individually* resistant to acid attack. The explanation of these structural changes is far too complicated to be compressed into a few sentences, and it needs some degree of metallurgical knowledge to understand it. We will, therefore, not dwell further on this point.

Certain facts about stainless steel must now be noted. In the first place, the surface must be as smooth and well polished as possible for the metal to exhibit its greatest resistance to attack by corrosion. This is because pores or cracks in the surface

lead to corrosion because the material at the bottom of these depressions or flaws becomes one of the poles of an electric current, and the cracks or cavities are consequently enlarged.

Another interesting fact is that the stainless steels containing 18 per cent. of nickel and eight per cent. of chromium are liable to the curious effect known as "work-hardening." This is the marked increase in hardness occurring when a piece of the steel in the cold condition is subjected to any degree of deformation such as is involved in hammering, drilling, pressing, rolling, etc. A simple explanation of work-hardening is difficult, but an endeavour to explain it is essential. When a certain stress, not sufficient to carry the steel beyond its elastic limit (see earlier article), is applied, it behaves as a perfectly elastic material, and returns to its original form and size when the stress is removed. If stressed too far, it does not go back to normal, but suffers permanent deformation. This

plastic deformation is accompanied by increased hardness. Why?

During plastic deformation the crystals of the steel are distorted in the same way as a pile of books which, when pushed, slide over each other. During the slipping process, atoms in the crystal planes or surfaces are torn from their usual positions. This means that energy is expended, and in a plastically deformed material this energy is stored up. Consequently, the potential energy of a steel deformed in the cold state is greater than that of the soft, unworked material. It is rather like lifting a weight to different heights and letting it fall to the ground. The higher the weight goes, the deeper a dent will it make when it falls. The apparent hardness of the weight thus depends on the height from which it is dropped. Similarly, the hardness of a cold-worked steel is proportional to the extent of its deformation. Eventually, slip along the crystal planes can no longer continue, and if the attempt is made to deform the steel still further, it breaks.

To avoid breaking the steel in this way, it becomes necessary to reheat it and then allow it to cool down from the proper temperature. This softens or anneals



Articles made of stainless steel have a particularly attractive finish.

it, gives it back its normal structure, and allows further deformation by bending, pressing, rolling, etc., to be applied without risk of breakage. With the 18-8 stainless steels, the best results are obtained by rapid cooling in a blast of air or by quenching in water. This type of stainless steel readily work-hardens, and frequent softening is necessary before it can be reduced by cold working to the required form and dimensions.

(Continued on page 142)

Railway News

Clapham Junction

Writers or speakers often quote similarity to Clapham Junction when wishing to instance some extreme example of intensive traffic operation or network of tracks, and rightly so, for that famous S.R. station has been described officially as "the busiest junction in the world, covering 35 acres and handling 2,500 trains per day." It is situated in mid-Battersea, a busy South London borough, and actually is over a mile from the suburb of Clapham. Its exceptionally heavy traffic is due to the fact that every train out of Waterloo, London's largest terminus, and Victoria (Central Section) passes through it, as well as goods, milk, and other unadvertised services to and from the West London or similar connecting link railways that abound in the neighbourhood.

The station really consists of three sections, each having four main lines, with subsidiary tracks or loops, so that there are 15 through roads. The Central main lines to Brighton and Sussex generally come from Victoria, 2½ miles away, over the vast width of Western Division tracks, by means of a flying junction, to pass through the east side of the station. Next come the Western main lines to the West of England, Bournemouth, Portsmouth and numerous branches. Adjacent to those is a large nest of sidings, constituting the principal carriage stabling and marshalling yard for the Waterloo steam services, which incidentally adds considerably to the interest and complexity of the locomotive working to be observed.

On the westernmost side, connected by footbridges, are the diverging subsidiary but busy lines from Waterloo to Windsor, Reading and Thames Valley residential areas, by way of Richmond and Staines. Nowadays most of the trains stopping at Clapham Junction are local or semi-fast electric. Some steam services call, but the majority of those on Waterloo as well as Victoria routes pass through, as do most of the main line or outer suburban electric trains.

Notwithstanding the intensive electric services passing almost continuously on one track or another at busy times, quite a remarkable variety of steam locomotives is to be seen, partly on account of the large number of different types and classes, often in small numbers, possessed by the constituent companies forming the S.R. For example, from the former London and South Western stock there are Drummond and Urie 4-6-0s; "H16" 4-6-2Ts Drummond 4-4-0, 0-6-0, 0-4-4T, and 0-6-0T classes; and Adams 0-4-2 "Jubilees", Ex-London, Brighton and South Coast types observable include each variety of 4-4-2, 4-4-0, 2-6-0, 0-6-0, 4-6-2T and 4-4-2T locomotives; "N15x" 4-6-0 rebuilds; "D3x" 0-4-4Ts; and various "E" class tanks. From time to time from the former South Eastern and Chatham stock come 4-4-0, 2-6-0 or 0-6-0 tender engines, as well as 0-4-4Ts.

Modern S.R. locomotives are well to the fore; among them those of the "Merchant Navy," "Lord Nelson" and "Schools" classes; mixed traffic 4-6-0s; "Q" and "Q1" 0-6-0s; 2-6-4 goods tanks; and the newer 2- or 3-cyl. 2-6-0 classes. W.D. and U.S.A.

2-8-0s were prominent recently. On through van or freight trains to and from their own systems, by way of one of the north-south connecting links we recently described, come L.M.S. 2-8-0, 0-8-0, 0-6-0, 2-6-2T and 0-6-0T engines; from the L.N.E.R. 0-6-0s or 0-6-2Ts from the G.N. section, with G.E. 0-6-0s, while G.W.R. 0-6-0 pannier tanks come near on their way to South Lambeth depot, of Hither Green yard. We have also heard of other classes of locomotives from all four groups appearing at this great junction on occasion, but space does not permit of their individual mention. Colour light signalling has been introduced since the photographs of the junction reproduced on these pages were taken.

Great Western Tidings

More new 0-6-0s are being built, numbered 2200-50. Nos. 2236-40 have recently been placed in service. They are similar to 2251 the series introduced in 1930, with extended side window cab, 5 ft. 2 in. wheels, working pressure of 200 lb. per sq. in. and a small degree of superheat. A few more of their predecessors, dating back 60 years to the introduction in 1883 of the 2301 class, have been withdrawn, yet

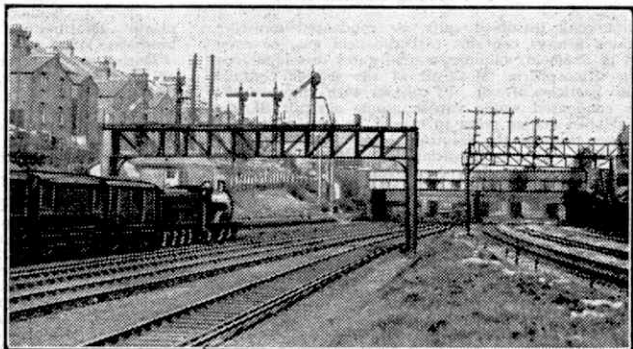

The south end of Clapham Junction, with Western Section lines on the left and those of the Central Section on the right. Photograph by H. C. Casserley.

many are still rendering good service as requisitioned W.D. locomotives, as they did between 1915 and 1919. On account of having been early in the field with more powerful 2-6-0 and 2-8-0 designs, the G.W.R. have not been a large user of 0-6-0s during the present century.

It is understood that a new intermediate 4-6-0 express type will shortly go into production. Meanwhile more modified "Halls" are coming into traffic from Swindon, numbered 6970 upward, also further 0-6-0 pannier tanks of the 4690 series, and additional L.M.S. pattern "8F" 84xx 2-8-0s for temporary use by the G.W.R.

We are informed that small 4-6-0 mixed traffic locomotive No. 7818 "Granville Manor" has been working on the Midland and South Western section from Cheltenham shed. The present exceptional locomotive variety on that cross-country line includes G.W.R. Moguls and "Bulldogs"; L.M.S. 2-8-0s and 0-6-0s; S.R. 4-4-0s and, sometimes, L.N.E.R. "B12/3" 4-6-0s, assisted on heavy special trains by different types available locally. No. 3254 "Cornubia," built in 1895 and the only remaining "Duke" 4-4-0 of the original batch, has lately been through shops, when her frames were strengthened and new cylinders fitted. No. 3371 "Sir Massey Lopes" has been scrapped; she was one of the larger inside cylindered "Bulldog" class, which is also now much denuded, while the engines comprised within it, like the "Dukes," have undergone many changes in the course of time.

Although a start was made with scrapping some years ago, withdrawal of the "Saint" class 4-6-0s

has proceeded slowly. Two more lately condemned are No. 2922 "Saint Gabriel" and No. 2975 "Lord Palmer," formerly "Sir Ernest Palmer," which were both familiar for many years on Bristol and South Wales expresses.

After building some experimental 4-6-0 and 4-4-2 engines, that far-seeing engineer, Mr. G. J. Churchward standardised from about 1907 his famous 2-cyl. "Saints" and his 4-cyl. "Stars." These were two of the most outstanding British types of their day, with the same tapered boiler carrying the high pressure of 225 lb. per sq. in. and equipped with ample steam passages. The 2-cyl. locomotives had the now familiar long stroke of 30 in. in conjunction with 18 in. outside cylinders, actuated through piston valves by a specially designed form of Stephenson link motion placed between the frames.

Although intermediate and arrival timings have necessarily been altered under war conditions on account of deceleration or restriction of service, the Paddington main line departure timetable still displays a remarkable similarity to 1939, with South Wales fast trains leaving at 55 min. past certain hours, those for Birmingham at 5 min. or 10 min. past, and so on. The time-honoured evening sequence of four expresses leaving at five minute intervals continues unchanged. They are the 5.55 for Swindon and South Wales, the 6.0 for Westbury and Weymouth, the 6.5 to Oxford and Worcester, and the 6.10 Birmingham and the North via Greenford. The first three all use the same track as far as Reading or beyond.

Allied Locomotives go Overseas

By the time these notes appear in print the last 200 of well over 1,000 British and American heavy freight locomotives, 2-8-0s, 2-10-0s and 0-6-0Ts, will have been withdrawn from service on British railways and sent overseas.

In 1942-3 400 powerful 2-8-0s specially built in the U.S.A. were loaned to the British railway com-



S.R. "Bournemouth Belle" passing Clapham Junction, north end. Photograph by H. C. Casserley.

various works of the main line companies.

Towards the end of 1942, the War Office agreed to lend the home railways 450 newly designed 2-8-0s, now well known to readers as the "Austerity" engines. The first went into service in January 1943, and in little more than 12 months this vast building programme was completed by private manufacturers in Scotland and England, in addition to the construction of 2-10-0 and 0-6-0T locomotives also on Government account. Progress of the Allied Armies in Europe has now made it imperative that these excellent engines should also be sent overseas. At the time of writing, 250 have been released and shipped to France or Belgium; the remainder are following at the rate of about 20 per week.

Prior to going abroad the whole of the "Austerity" engines have undergone extensive overhaul to ensure their running at least 25,000 miles trouble free if possible. These final preparations have been carried out in the railway workshops at Ashford, Cowlands, Crewe, Darlington, Derby, Doncaster, Eastleigh, Gorton and Stratford, thus entailing considerable strain on those already overtaxed plants. This has resulted in retarding repair and new building work on the companies' own locomotives, the effect of which is being seriously felt in the day-to-day operation of the ordinary services. The loss of so many modern powerful engines has also caused some freight train dislocation. This temporary difficulty is due to the necessity of ensuring that the locomotives reaching the fighting fronts shall be in as perfect working order as practicable.

More Fine Engines in South Africa

The South African Government Railways have long been outstanding as operators of fine, large locomotives, and handsome, roomy carriages on a rail gauge of only 3 ft. 6 in. This great Dominion is contributing to the war effort on a large scale and is exporting large quantities of coal, which has to be conveyed by train, so that passenger as well as freight demands have been very severe on the locomotive department. It was not

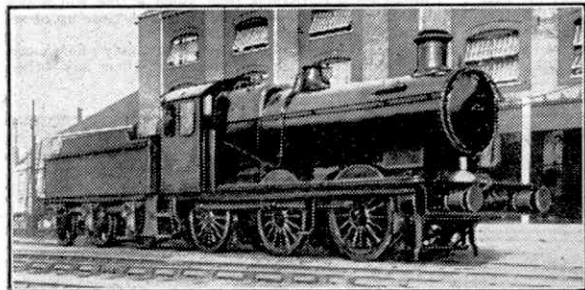

One of the standard 22xx class of G.W.R. 0-6-0.

possible for any new construction to be put in hand at the British works of Messrs. Beyer, Peacock and Co. Ltd., or the North British Locomotive Co. Ltd., until about a year ago, but delivery is now being effected from those plants of further series of powerful 4-8-2 class "15E" main line engines. The boilers of these engines are the largest ever fitted to a non-articulated locomotive running on 3 ft. 6 in. gauge, and indeed are vast by British 4 ft. 8½ in. standards.

panies to help in handling the enormous quantities of munition and supply traffic consequent upon the stationing of American Forces in this country. These engines were illustrated and described in the November 1943 issue of the "M.M." They have all now been withdrawn for service on the Continent, having been made ready for shipment at Eastleigh and Ebbw Vale, South Wales, works. On first arriving in Britain they were put into running trim at the

Photography

Some Spring Pictures

By E. E. Steele

WHEN the warmer days of Spring come round there is much fun out of doors, and it is particularly good to visit the fields and woods once more.

Bird-nesting is one of the main attractions to boys of every age, and though it is interesting to make a collection of birds' eggs, it is far better to have a collection of photographs of them, for the bird is then left to rear her young in peace. Birds do a tremendous amount of good in devouring grubs and pests which feed upon our crops.



Partridge's Nest.

It is fairly simple to photograph the nests of birds in the early Spring before the green leaves have opened and hidden them away. Some foolish, or rather young birds, build their nests in very exposed positions, and advantage should be taken of these to make photographs. If a nest is well hidden in the middle of a bush it is best to leave it alone, because it cannot be photographed without cutting branches away, and this may cause the bird to desert her nest.

Ground nests, such as those of partridge, skylark, etc., are the easiest to photograph when once discovered, and the nest need not be disturbed at all. Allow rather more exposure than you would for a portrait snap in similar conditions.

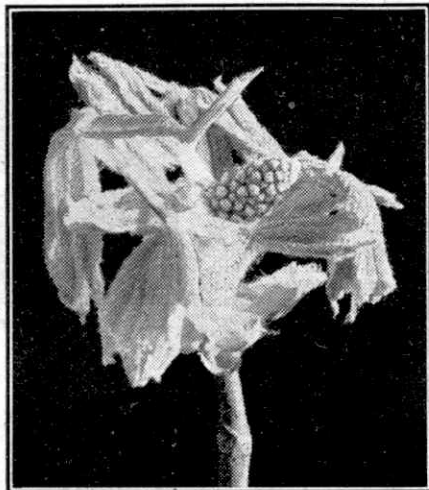

Horse Chestnut Bud Opening.

Only one thing can rival the popularity of bird-nesting, and that is "frog-egging," or "tadpoling," and a visit to the pond in Spring is always hailed with delight. You won't do much harm by filling your jar with frog's eggs, but there is also the opportunity to make interesting pictures of the frogs actually going about the business of egg-laying.

I know one small pond which seemed almost full of frogs whose noisy croaking went on all through the night. This pond was easy to reach, with no obstacles in the way, so a number of pictures were made. At first the frogs were rather shy and quickly dived under the water, but they soon popped up their heads again and took no further notice of the photographer.

It seems a far cry to the time when the "conkers" are ready in Autumn, but the chestnut trees which later produce the welcome "conkers" look very fine in their Spring dress, the flowers reminding one of candles on a Christmas tree. Such a tree will make another good photograph, or perhaps a close-up of an opening bud will be attractive.

Taking it all round, the Spring probably offers more opportunities to the photographer than any other season.

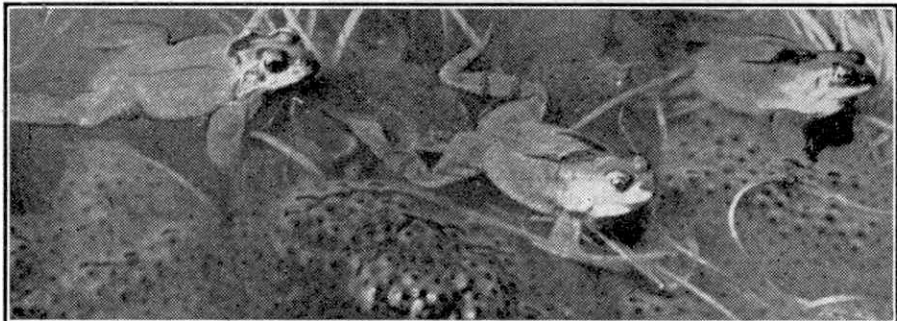

Frogs and their Eggs.

Electric Lights for L.N.E.R. Engines

TO overcome some of the disadvantages of the oil-burning head lamps used hitherto, and to provide engine crews with illuminated gauge and control points in locomotive cabs, the L.N.E.R. have worked out a new system of locomotive electric lighting in conjunction with the Metropolitan-Vickers Electrical Co. Ltd. Four "Pacific" locomotives of Class "A2/1" are to be provided with this equipment as an experiment, and engine No. 3698 of this class has already been so fitted.

Electric power is obtained from an axle-driven generator mounted on an extension screwed and welded into the end of the trailing axle of the leading bogie. The generator is, as nearly as possible, totally enclosed, and its generator winding produces alternating current that is rectified before being led to the battery, a 5-cell 6 v. "Nife" one of 35 amp. hr. capacity that supplies current for the lamps when the engine is stationary. This is isolated from the generator field by a mechanically operated switch under the control of the steam regulator handle. On starting, the generator field is excited from the battery, which is placed in a cabinet beneath the fireman's seat in the engine cab; but as soon as the engine speed reaches 10 m.p.h. sufficient voltage is generated to provide a charging current.

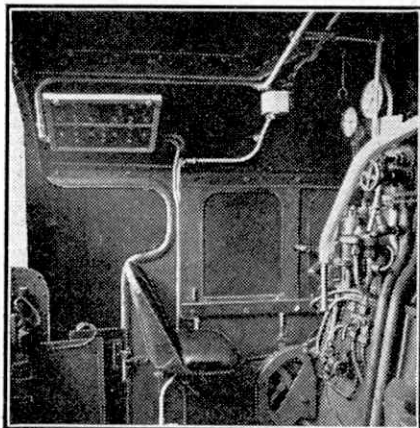

The control panel for the lamps of L.N.E.R. No. 3698 is fitted on the roof of the cab, as shown in this illustration.

At the same speed, 10 m.p.h., the current is supplied to the whole system from the generator, and as the speed increases the



L.N.E.R. "Pacific" No. 3698, of the "A2/1" Class, which has been fitted with electric lights on the front of the engine and rear of the tender, and also in the cab. Photographs by courtesy of the L.N.E.R.

current rises rapidly to the full value and is subsequently maintained constant.

In order to avoid anything in the nature of plugging-in, or of handling loose connections when variation in the number and disposition of headlamps is required for traffic purposes, a full complement of electric lamps to meet all requirements is permanently fitted both on the front of the engine and on the back of the tender. These lamps are comparatively small, and they are painted black to render them as inconspicuous as possible during daylight periods. The daylight indication of the type of traffic on which the engine is working is given by means of hinged white discs, which can be brought into operation as required.

The control panel is fitted into the left-hand side of the cab roof, as shown in the lower illustration on this page; and on the face of the panel is reproduced, in diagrammatic form, the front of the engine and the back of the tender, with pilot lights that indicate which of the lamps are in use at any particular time. In addition to the locomotive and tender head and tail lamps, spot lighting is provided in the cab to illuminate the vacuum and pressure gauges, etc.

Among the Model-Builders

A New Feature Introduced

By "Spanner"

READERS will note the new heading to these pages, which hitherto have been known as the "Suggestions Section." In the past this section has provided space

their models, with a view to publication.

All model-builders, especially those who invent models of their own, occasionally run up against unexpected difficulties.

This is particularly likely to happen in these days of scarcity of parts. Usually the difficulty is overcome, and other model-builders will be glad to know how it was done. When the problem remains unsolved, however, readers will be keen to have the chance of lending a helping hand. So, whether your problem is solved or not, let me know about it for the benefit of fellow enthusiasts.

I want as many readers as possible to contribute to these pages. Payment will be made at the usual rates for all material and all photographs or drawings used. This is not a competition with a closing date, but a permanent feature; so that contributions can be sent in at any time.

All letters containing contributions should be addressed: "Model-Builders, Meccano Magazine, Binns Road, Liverpool 13."

A NOVEL TRIP CLUTCH

I received recently a most interesting letter from an old Meccano friend, Alan Partridge, Northampton, in which he told me of various gadgets he has designed.

Among them is a trip clutch of a type I cannot remember having seen previously. I reproduce Partridge's own excellent drawing, from which the construction of the clutch should be clear. Two Threaded Pins, which engage holes in a Double Arm Crank, are mounted on a loose Bush Wheel, which is kept apart from a fixed and driven Bush Wheel by Washers and a Collar placed on the inner end of a trip lever. In this position the clutch transmits a drive without offering any frictional resistance. If an obstruction is placed in the path of the trip lever as the clutch rotates, the Collar at the inner end of the lever moves sideways, and Springs on the shanks of the Bolts then withdraw the Threaded Pins from the holes in the Crank. Threaded Bosses are used as counterweights to the trip lever.

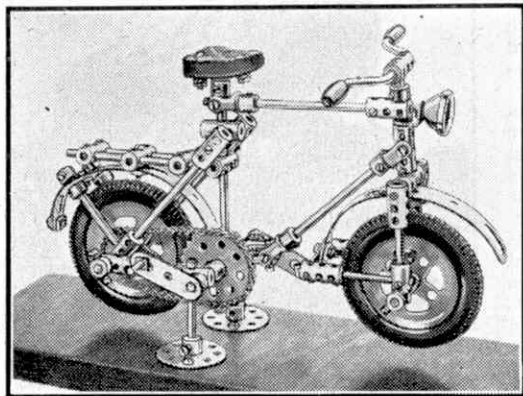

A fine model bicycle that makes good use of Couplings. It was built by Mr. G. Harrington, Leicester.

in which readers' own models were described and illustrated, but it has dealt almost entirely with mechanisms. "Among the Model-Builders" will continue to describe models and mechanisms, but in addition it will include contributions of any kind that are of general interest to Meccano enthusiasts.

For instance, I receive from readers many interesting letters telling me of what they have been doing with their Outfits; of school or other hobbies exhibitions in which they have won prizes, or of some idea that has occurred to them which they think may interest other model-builders. In future, extracts from these letters will be reproduced as space permits. I shall be glad to receive also photographs of model-building readers, preferably with

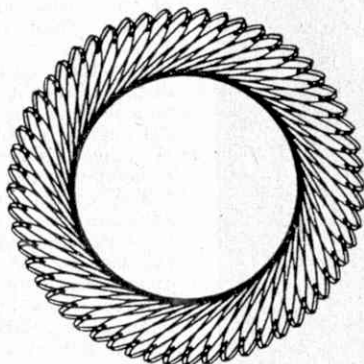

One of the many interesting designs produced on a Meccanograph.

MECCANO DESIGNING MACHINES

A suggestion that may help readers who are interested in Meccano designing machines such as the Meccanograph, comes from R. Blackwood, London. It is well known that an ordinary pencil does not give very satisfactory results when used in the Meccanograph. These difficulties can of course be overcome by using a fountain pen, but occasions arise when one is not available, or for some reason or other it may not be desired to use ink. In such cases Blackwood suggests the following procedure. The design is traced with an indelible copying pencil with a hard lead, and when completed the paper is held over a jet of steam for a while. This process darkens the pencil lines, brings up the detail and improves the appearance of the design considerably. A design produced in this way is illustrated here.

NOVELTY IN BICYCLE CONSTRUCTION

Mr. G. Harrington, Leicester, has built in spare moments the interesting model of a bicycle on the previous page. His model is notable for the extensive use he has made of Couplings. I think there are about 22 all told. In this way he has attained great rigidity and has avoided the necessity for bending rods or other parts, but unfortunately the pedal width has become rather excessive.

On the whole I consider this a most interesting model, and I congratulate Mr. Harrington on his workmanship.

A READER'S PROBLEM SOLVED

Ronnie Smith, Edgware, wrote for advice in connection with a model crane gear-box that he was building. He wanted to mount a pinion on a shaft in such a manner that it could either be carried around bodily with the shaft, or remain stationary while the shaft rotated freely in its boss. Smith was not quite clear as to how this could be done. It is in a case of this kind that the Dog Clutch (Part No. 144) is of great assistance.

As many of my readers will be aware, the Dog Clutch consists of one male and one female member. In the arrangement illustrated it is used in conjunction with a Socket Coupling. The female member 1 is fixed to the shaft and the male member 2 is held in Socket Coupling 3, which carries Pinion 4 and is free on shaft 5. The two parts are engaged by sliding the Coupling upward.

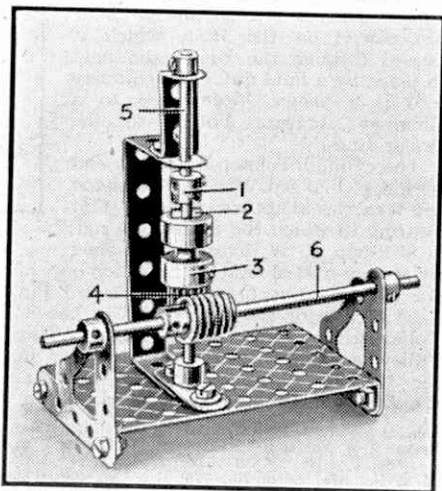

The dog clutch mechanism referred to on this page.

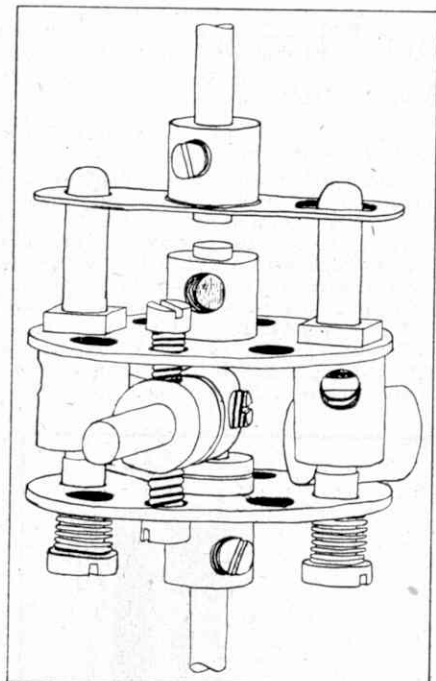

A reproduction of a drawing by A. Partridge, Northampton, showing his trip clutch mechanism.

A DUTCH BOY'S LETTER

Among my correspondence recently I was delighted to find a very interesting letter from a Dutch Meccano boy enclosing a drawing of a model crane that he wished to enter in an "M.M." competition. It is very good to know that in spite of all the difficulties and troubles the war has brought to his country our Dutch friend still maintains his interest in Meccano. The following is an extract from his letter, reproduced exactly as he wrote it:

"I am a Dutch boy of eighteen years. One of our good English friends who was on leave in England brought for me a 'Meccano Magazine' when he came back some days ago, because he knew I was a big admirer of Meccano. If I have some free hours, I am always busy with it, and I regret it very much that it is not possible to buy Meccano Outfits during the war. But after war I will fetch in my loss. Is it not possible to print 'M.M.' after war also in Dutch? I am sure many Dutch boys, who should like to read 'M.M.', cannot do so because they cannot understand English, or not good enough. There are many technical expressions who are difficult to understand for us in English, and many of them are only in a technical dictionary. And it should be a pity if not each boy should be able to profit by such an excellent Magazine for boys!

"I finish with the wishes that war may be finished very quickly, and that we can buy our Meccano very soon like before war!

Your friend—JAN.

"P.S.—Please! forgive me my mistakes I have made in this letter."

So the Meccano idea lives on in Holland in spite of Nazi brutality!

New Meccano Models

Steam Engine and Boiler—Tricycle

TO form the base of the fine model vertical steam engine and boiler shown in Fig. 1, two $5\frac{1}{2}'' \times 2\frac{1}{4}''$ Flanged Plates and two $12\frac{1}{2}''$ Angle Girders are required. These are bolted together as shown, and an E20B Electric Motor is then mounted on one end of the base, leaving the other end free to accommodate the engine plant. The basic structure of this consists of three $3\frac{1}{2}'' \times 2\frac{1}{2}''$ Flanged Plates, two of which are bolted to Angle Girders fixed to the $5\frac{1}{2}'' \times 3\frac{1}{2}''$ Flanged Plate, while the third Plate 1 is bolted between them as shown. A boiler complete with one End is then fixed in position by means of Angle Brackets. It is fitted with a water gauge 2 consisting of two Handrail Supports and a $1''$ Rod, and a steam gauge 3 formed by a $\frac{3}{4}''$ Flanged Wheel fixed by its boss on a $1''$ Screwed Rod held in another Handrail Support. The gauge dial is a disc of paper suitably marked in ink and stuck to the Flanged Wheel with paste.

Each of the two engine cylinders is a Sleeve Piece 4, which is fixed to the Boiler by a $\frac{1}{2}''$ Bolt. The Bolt is passed through one of the holes in the Sleeve Piece from the inside, and a nut is then placed on it and tightened up against the Sleeve Piece. Then a Washer and a Collar are placed on the Bolt, which is passed through the Boiler and held in place by a final nut. The chimney also is a Sleeve Piece fixed to a Chimney Adaptor bolted to the Boiler End.

The cylinder is capped at each end with a $\frac{3}{4}''$ Flanged Wheel. The piston rod 5 carries at its lower end an End Bearing to which the connecting rod, a $3''$ Strip 6, is pivotally attached by a lock-nutted bolt. The other end of the Strip is slipped over a Threaded Pin fixed in one of the inner holes in the $3''$ Pulley that forms the flywheel. This Pulley is fixed on a Rod 7 journalled in the $3\frac{1}{2}'' \times 2\frac{1}{2}''$ Flanged Plates of the base. A Collar holds the Strip in place on the Pin.

Parts required to build model Vertical Engine and Boiler: 2 of No. 4; 2 of No. 8; 3 of No. 12; 2 of No. 16b; 1 of No. 18b; 2 of No. 19b; 5 of No. 20b; 28 of No. 37a; 26 of No. 37b; 6 of No. 38; 2 of No. 52; 3 of No. 53; 4 of No. 59; 1 of No. 82; 2 of No. 111a; 2 of No. 115; 3 of No. 136; 1 of No. 162a;

1 of No. 162b; 3 of No. 163; 1 of No. 164; 2 of No. 166, E20B Electric Motor.

Model-builders who enjoy building small realistic models will be interested in the neat tricycle shown in Fig. 2. Construction of this is begun by bolting two Cranks back to back with a $1\frac{1}{2}''$ Strip 1 between them as shown. Two units of this type are built up and then are mounted one on each end of a $4\frac{1}{2}''$ Rod, which carries also a Coupling 2. The rear wheel axle is a $6\frac{1}{2}''$ Rod journalled in the bosses of the Cranks, and in addition to the road wheels,

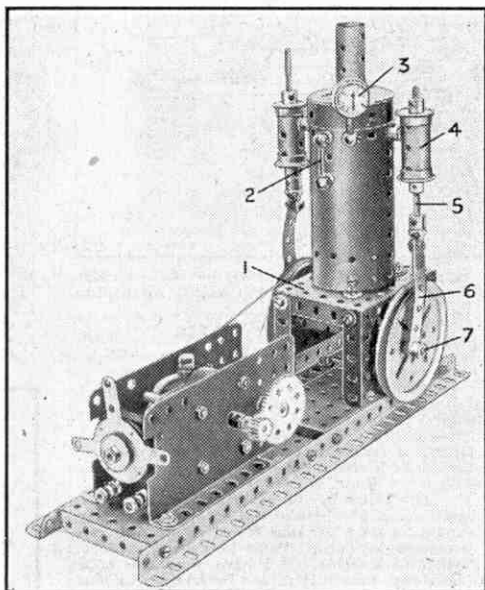

Fig. 1. A model vertical steam engine and boiler.

which are $2''$ Pulleys shod with Rubber Tyres, it carries a $\frac{3}{4}''$ Sprocket 3. The Pulleys are spaced from the bosses of the Cranks by three Washers. A $1'' \times \frac{1}{2}''$ Angle Bracket 4 is bolted to the protruding end of the $1\frac{1}{2}''$ Strip on each side of the model. These Angle Brackets support the mudguards, each of which is composed of two Forward Slotted Strips.

The saddle is a Flat Trunnion bolted to a Trunnion that carries a Rod Socket 5. On the shank of the Rod Socket is a Hinge

to which is bolted a $1\frac{1}{2}$ " Strip that represents a saddle bag. A 1" Rod is gripped in the Rod Socket, and this carries another Coupling 6. The whole of the saddle unit is then mounted on the shank of a Handrail Support fixed on a $1\frac{1}{2}$ " Rod held in the Coupling 2. By means of the construction adopted the saddle can be raised and lowered, or adjusted to or from the handlebars, to give the most suitable riding position.

The lower bracket consists of a $2\frac{1}{2}$ " Rod held by a Coupling 7, which in turn is fixed on a 1" Rod gripped in the Coupling 2. The $2\frac{1}{2}$ " Rod carries Couplings 7 and 8, in the first of which is mounted a $1\frac{1}{2}$ " Rod that bears a 1" Sprocket Wheel and two Cranks that form the pedal cranks. A Threaded Pin is fixed in each Crank.

A $\frac{3}{4}$ " Bolt passed through Coupling 8 protrudes into the boss of a large Fork Piece 9, which is locked firmly upon it by means of its grub screw. Two $2\frac{1}{2}$ " Cranked Curved Strips are fixed to the Fork Piece and to their upper ends are bolted a small Fork Piece 10 and another large Fork Piece 11 to form the head of the frame. The front fork consists of two 2" Strips, each of which carries a Crank 12 and is bolted at its upper end to one arm of a large Fork Piece 13. A $2\frac{1}{2}$ " Rod is held in the boss of the Fork Piece 13 and passes freely through the bosses of Fork Pieces 10 and 11. On its upper end is fixed a Double Arm Crank 14, to each arm of which a $2\frac{1}{2}$ " Cranked Curved Strip is bolted to form

the handlebar.

The front mudguard consists of two Formed Slotted Strips bolted to a 1" Reversed Angle Bracket. The latter is slipped over the Rod of the front fork before it is placed in position in the head

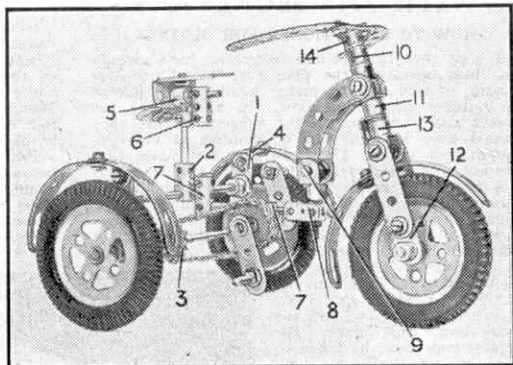

Fig. 2. A sturdy and realistic model tricycle.

of the frame.

The pedal Sprocket is connected to the Sprocket on the rear axle by Sprocket Chain.

The front wheel is a 2" Pulley fitted with a Tyre and rotates freely on a 1" Rod gripped in the Cranks 12.

Parts required to build model Tricycle: 3 of No. 6a; 2 of No. 12b; 1 of No. 14; 1 of No. 15b; 2 of No. 16a; 2 of No. 18a; 2 of No. 18b; 3 of No. 20a; 19 of No. 37a; 18 of No. 37b; 20 of No. 38; 10" of No. 40; 8 of No. 62; 1 of No. 62b; 5 of No. 63; 4 of No. 90a; 1 of No. 96; 1 of No. 96a; 1 of No. 111; 1 of No. 114; 3 of No. 116; 1 of No. 116a; 1 of No. 124; 1 of No. 126; 1 of No. 126a; 1 of No. 136; 3 of No. 142a; 1 of No. 179; 6 of No. 215.

"March" General Model-Building Competition

Have You Sent in Your Entry?

We wish to remind readers that the "March General Model-building Competition," details of which were announced last month, will remain open for entries until 30th April, so that there is still time for model-builders who have not yet sent in their entries to take part in the Contest. All a competitor has to do is to build a Meccano model of any type entirely from his or her own ideas. The only condition is that the model must be the competitor's own work. There is no age limit, and any size of Outfit may be used in building models.

After the model is built the next job is to obtain a suitable illustration of it. This may be either a photograph or a sketch. The sender should write his or her name and address on the back of the illustration and enclose it, together with a brief description of its operation and construction, in an envelope addressed "March General Model-building Contest, Meccano Ltd., Binns Road, Liverpool 13."

Entries will be grouped into one section; but a

competitor's age will be taken into consideration when assessing the merits of his work.

The prizes to be awarded for the best built and most interesting models received are: First: £2/2/-; 2nd, £1/1/-; 3rd, 10/6. There will also be consolation prizes of 5/- each for entries of merit that do not gain a major award.

The closing date for entries is 30th April, but entries should be posted as soon as they are ready and not kept until the closing date approaches. All prize-winners will be notified by letter, and a full list of the awards, together with illustrations of some of the best models, will be published in the "M.M." as soon as possible after the closing date.

It should be noted that successful entries become the property of Meccano Ltd., but photographs or sketches of unsuccessful models will be returned to senders provided that a stamped addressed envelope of the necessary size is enclosed with the entry for that purpose.



Club and Branch News



WITH THE SECRETARY

HOW TO RAISE MONEY FOR OUTINGS

I hope that Leaders and secretaries have already put into operation the plan that I outlined last month, of arranging as many details as possible of an outdoor programme now. In addition to the games and excursions that I suggested then, they should keep in mind the possibilities of visits to factories or works. There are very few Clubs that are not within easy reach of places of this kind that will be of the greatest interest, and probably will provide many good ideas for model-building; and it should be possible to organise visits to some of them, in spite of the restrictions that wartime has brought with it. The best procedure is to write first to the authorities concerned to ask for permission to make a visit, and when this has been given, and the date and time fixed, the utmost care must be taken to keep strictly to the arrangements that have been made, and to observe during the visit itself any conditions that may be made.

One thing that has to be borne in mind is that excursions and even visits may involve a little expense. This need not be a worry. The best way to make sure that all members can take part in the pleasures that outings bring is to start a bank. A senior member or perhaps the Leader himself takes charge of this, and members bring him small sums weekly. It is surprising how soon these contributions mount up to a respectable sum, and if a beginning is made now a scheme of this kind should solve all money problems in connection with the programme for the coming outdoor season.

PORTRAITS AND GROUP PHOTOGRAPHS

Club outings give splendid opportunities for Club photographs. Nothing could be finer than a group photograph of members enjoying a visit to the seaside, or to some place inland where they can have an afternoon's enjoyment, and I like to reproduce such photographs on this page so that the smiles on the faces of those appearing in them will show to all readers how much enjoyment readers get from association with their Clubs. If films can be obtained at all, therefore, photographs should be taken whenever a Club goes for an outing of any kind. The actual photography usually presents little difficulty, for there must be few Clubs without camera owners among their members.

While on the subject of photographs I want to remind Leaders and Secretaries of Clubs, and the corresponding officials of Branches, that I am always delighted to receive good portraits, whether these are large ones taken by professional photographers or snapshots. I want every Club and Branch throughout the world to be represented in my portrait gallery.



W. Smith is Secretary of the Thornton Grammar School M.C., which was affiliated on 25th July, 1944, and is now flourishing under the skilful Leadership of Mr. H. A. Beaton. The Club has sections for Engineering, Woodwork and Aero-modelling, and members are very keen; after a recent Lecture by a master at the School they could scarcely be persuaded to stop asking questions! A Magazine Library also is carried on and is a great success.

CLUB NOTES

STAPLEFORD M.C.—The programme has included a "Quiz" meeting, a Spelling Bee and a Lecture on "Jupiter" by Mr. C. W. Hunt, Leader. A Debate on the value of aeroplanes also has been held, and one evening was devoted to Hornby Train operation. Members continue busily with Model-building. Club roll: 8. Secretary: P. R. Dennis, 36, Hickings Lane, Stapleford.

PHOENIX (SOUTHPORT) M.C.—Model-building Competitions of various kinds are held regularly. A Hornby Train Section has been formed to carry out operations on an excellent double track that is being extended. Lectures on "Plastics" and other subjects have been given. Good progress is being made with the furnishing of the Club Room, and a canteen is being developed. A Magazine has been started. Club roll: 15. Secretary: P. Lapes, 25, Norwood Crescent, Southport, Lancs.

SOUTH AFRICA

MALVERN (JOHANNESBURG) M.C.—The Club is continuing its usual good work in spite of wartime difficulties. Competitions are held regularly and in addition there have been visits to the Central Fire Station and elsewhere, a Mock Trial and General Knowledge Tests. Games also have been played, and Model-building Competitions have aroused great interest. The customary Christmas Effort on behalf of the Epworth Home was made. Club roll: 23. Secretary: D. Eblen, P.O. Box 8, Cleveland, Johannesburg, South Africa.

BRANCH NEWS

GAINSBOROUGH—Operations to timetable have continued with good results. Slight alterations have been made to the layout to give better running, and additional rolling stock has been brought into use. New constructions are a locomotive shed, a coal stage and a breakdown train. The plan of the layout is being revised. Secretary: F. J. Newman, 26, Birrell Street, Gainsborough.

BANBURY—Great interest is taken in ambulance trains and other "Specials," and members show great skill in re-arranging passenger timetables at short notice to allow these to be run. An armoured train is to be assembled. A Meccano Fair was constructed at the lineside, and proved a great attraction. Secretary: D. Hopkins, 348, Warwick Road, Banbury, Oxon.

GIFFNOCK—Timetable operations on the Branch layout are carried out regularly, each member taking up a recognised position. A goods platform and other requirements have been added to extend and improve the layout. A Visit has been paid to Polmadie Motive Power Depot, where members were allowed to inspect the cab arrangements of locomotives. Secretary: S. S. Cant, 13, Torres Avenue, Giffnock, Glasgow.

From Our Readers

This page is reserved for articles from our readers. Contributions not exceeding 500 words in length are invited on any subject of which the writer has special knowledge or experience. These should be written neatly on one side of the paper only, and should be accompanied if possible by original photographs for use as illustrations. Articles published will be paid for. Statements in articles submitted are accepted as being sent in good faith, but the Editor takes no responsibility for their accuracy.

A HISTORICAL COTTAGE

Burns' Cottage, the birthplace of Scotland's national poet, is at least 250 years old and within the cottage itself nothing is changed. The old iron pot still hangs over the wide hearth, the large wooden cradle sits on the floor, and the original furniture remains, with small items such as a pair of bellows and the clock in their respective places. The clock is at least 200 years old and must have "ticked out" Napoleon as it will, no doubt, "tick out" Hitler.

The accompanying photograph shows Sam Morrison, Scotland's oldest thatcher, repairing the roof of this famous cottage. Sam was 80 years of age when I took the picture, and unfortunately he has since died. He was born in Ayr, and fought in the Zulu War, during which he thatched huts for the troops.

Sam's work at Burns' Cottage covered a period of 40 years, beginning in 1900. When he was a boy most of the houses in Ayrshire had thatched roofs, but now there are less than five with this covering. He once recounted an interesting incident that happened when he was sailing to South Africa at the time of the Boer War, in which he also took part. The vessel in which he travelled was rather small for the number of troops on board, and some of the men had to lie on deck. When they reached the neighbourhood of the Equator, it became too hot to do this uncovered, but Sam solved the situation by thatching a thin roof over part of the deck with straw from packing cases.

W. D. GRAHAM (Girvan).

A LOCOMOTIVE WEATHER-VANE

On an office roof at Birkenhead Town Station, near the main entrance of the Mersey Tunnel, there is a rather remarkable weather-vane that is a silhouette of one of the 2-2-2 engines that were the first to run into Birkenhead in 1840. The vane itself is over 100 years old, and is skilfully cut out of copper.

Except for a brief overhaul at Swindon G.W.R. works recently, when ball-bearings were fitted to the pivot, it has seen continual service since those early days, when Town Station was the Merseyside terminus of the Chester and Birkenhead Railway, opened in September 1840. CYRIL R. ROWSON (Liverpool 11).

A RUN ON A SOUTH AUSTRALIAN TRAIN

The daily stopping train to Adelaide from Renmark, South Australia, is usually made up of two passenger coaches, and one brake and luggage van. But when I made the run here described a small 4-6-0 Rx class engine No. 219 hauled four coaches and a brake van, a total of 180 tons.

Leaving Renmark at 10.24 a.m.—the train passed

over the River Murray into semi-desert country, where mallee is grown, and small quantities of wheat. The speed of the train here is reduced by sand drifts on the track, and several times the train crew were forced to shovel the sand away from the line. In

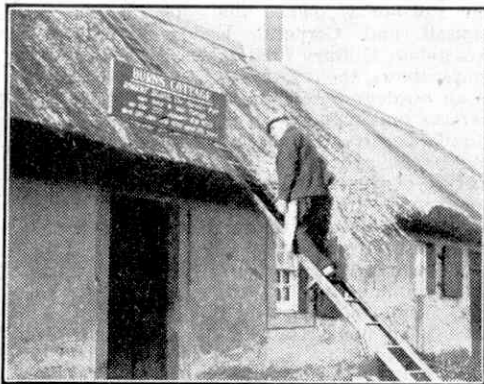

Sam Morrison, a veteran thatcher, renewing the thatching of Burns' cottage near Ayr. Photograph by W. D. Graham, Girvan.

some places, where there was little sand, an average speed of 40-45 m.p.h. was attained.

At Tailem Bend, a big railway town 75 miles from Adelaide, the engine was changed for No. 501, a huge 4-8-4 "Mountain" type of the "500" class. The South-East train is usually combined with the Renmark train here, but on this occasion seven coaches were coupled to the brake van, and the South-East portion was run separately to Adelaide.

Departing at 4.53 p.m. with a 430-ton load, No. 501 quickly accelerated and reached 52 m.p.h., but then had to reduce speed to cross the Murray again, over the biggest bridge in South Australia. After stopping at Murray Bridge for water, an average speed of 45-50 m.p.h. was kept up. As the scenery began to change from undulating land to the hilly Mt. Lofty Ranges, speed slackened to 20-30 m.p.h., but after passing through Mt. Lofty station the down grades allowed better speeds. Passing through several tunnels, one of them three-quarters of a mile long, the train entered the suburbs and came to a stop in Adelaide at 8.20 p.m. instead of 8.08 p.m., 12 min. late. The total distance is 214 miles.

LINDSAY G. ROSS (South Australia).

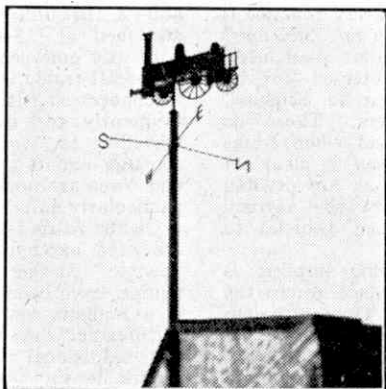

The remarkable weathervane at Birkenhead Town Station. Photograph by C. R. Rowson, Liverpool.

A Hornby Layout in Australia

LAST month we described the latest developments on a Hornby layout representing part of the L.N.E.R. in Vancouver. Now we have details of an equally interesting system worked mainly by G.W.R. stock that is situated in far-away Australia. Our account comes from Leading Aircraftman Senior, R.A.A.F., of Woodville, Adelaide, where the railway is owned and operated by himself and Corporal Keddie of the Australian Military Forces. As the photograph shows, the railway is an outdoor one. The various buildings are all stoutly constructed, and the roads, which are a feature of the miniature countryside, are properly made and tarred so that the whole stands up to the weather in a satisfactory manner.

The line is for the most part single track, and is of the non-continuous type. It is pleasantly varied in layout, the towns served being respectively "Southport" and "Borderton," the two termini, and "Swinton" and "Dennisville" which are through stations. There is also a station at "Southport North" where the local gasworks is served by a siding.

An interesting feature that has been copied from Australian railway practice is found at the level crossing at "Swinton," where the railway and a main road intersect. The crossing is protected not by the type of gates familiar in England, but by pole-type barriers. These lie horizontally across the road when trains are due, but when the way is clear for road traffic the poles, which are pivoted at one end, are raised to the vertical position and so allow road vehicles to pass over the line.

"Borderton," as its name implies, is supposed to represent a place where the line enters another state. Thus, although it is a terminal point as far as actual working is concerned, engine changing, train examination and so on are supposed to be carried out there as is usual at such "frontier stations." The "Great Westerner"

which is one of the principal trains, is a light fast train normally consisting of three of the smaller Hornby Pullmans and a Guards Van. Its load is sometimes increased by a Milk or Refrigerator Van conveying special traffic. The engine is invariably a Hornby No. 1 G.W.R. Other trains are worked by No. 2 Special and No. 2 Special Tank Locomotives, which deal capably with the more heavily loaded services. The lighter local traffic is hauled by two No. 1 Tanks.

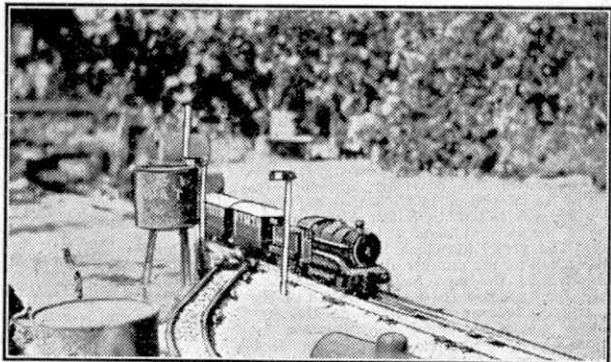

A "stopping" train leaving "Southport" on the layout of Leading Aircraftman Senior and Corporal Keddie, Woodville, Adelaide.

Although G.W.R. stock predominates, the other British railways are represented on the line, this being supposedly due to wartime "pooling" arrangements. There are some 30 vehicles for goods traffic, and a Breakdown Van and Crane is stationed at "Southport" ready to deal with any emergency.

Special traffic is dealt with on occasions in connection with troop movements, and frequently too to cater for the crowds travelling to "Swinton," where important sporting events are held. No. 1 Coaches and Vans are normally used and they are particularly suitable for this type of work.

On the roads Dinky Toys motor vehicles are used extensively, but the miniature "people," in the absence of the standard figures, have been formed out of Plasticine in a realistic manner. Apart from these features and the scenic surroundings of the line, additional realism is found in the electric lighting system. A miniature power station supplies current to numerous 2.5-volt lamps in the buildings and yards.

Yard Operation on a Dublo Layout

IT is generally agreed that imagination plays an important part in the development and operation of a miniature railway system. There must be supposed reasons for the existence of the line and for the traffic that it handles; the nature of the traffic of course governs the rolling stock in use, and so on. Actually the making up of the "story" of the railway is a most fascinating part of the general

in the yard. Therefore we may expect to see only a few open wagons alongside the loading bank; vans will be the more common type.

Important "perishable" trains therefore can be made up using the different vans of these types that the model railway owner may be lucky enough to possess. Several of the vans may arrive at the depot as a separate train supposedly bringing loads

from local stations. They can be united to one or two more that have been "loaded" at the depot, and then the whole train is moved out into the yard ready for the engine that is to take it on its main line journey. The usual thing will be for a Dublo Tank to work the local part of the run and perform the necessary movements at the depot and yard; then, if there is one on the line, a Dublo streamline 4-6-2 can back on for the main line stretch.

Operations of this kind are extremely interesting in themselves, but become even more so when the scheme is worked out in accordance with a particular idea. Similar workings can be carried out for traffic that is supposed to arrive at the depot from distant centres. It may be of course, with the usual model railway licence, that the train we saw prepared and despatched in the last paragraph becomes the new arrival after several trips round the main line, with perhaps an intermediate stop for "locomotive purposes" or for "train examination"

Routine stops of this kind figure in the working arrangements for most real freight trains.

Ordinary coal trains that arrive will probably require "breaking up" or re-marshalling, so that the wagons can be taken round to the local yards in the district. This sort of work is done by the local "pick-up" goods services, as also is the collection of the corresponding "empties" and of vehicles bearing miscellaneous traffic. This type of work has been referred to several times in these pages, and can be carried out quite well even on a small layout, with perhaps no more than a couple of sidings forming a local yard like the one seen in the lower illustration.



Operations in progress at the goods depot. Note the arrangement of the platforms and the train of vans being shunted in the foreground.

business. We do a great deal of it unconsciously as we plan this or that series of operations, and perhaps only realise the extent of the little railway "kingdom" we have created when someone asks us questions about it. Let us see how this works out in connection with the different operations carried out in a Dublo goods yard.

We are not concerned with the actual rail layout of the yard, as this varies with practically every miniature railway system, according to the ideas of the owner and the space in which he has to carry them out. In most cases the yard will serve a goods depot, either the standard building in a small yard, or this used in conjunction with some other building forming a warehouse, as previously suggested in these pages. The latter arrangement is very suitable for a "town depot."

Road motor vehicles play an important part in connection with goods depot working on most layouts. Dinky Toys, if available, or other miniature motor wagons and vans are used. Sometimes they are used more as "scenic" items, but on many layouts a feature is made of road operations, and the little vehicles are moved along the "roads" in connection with the trains. Therefore we see several of them about the depot shown in the upper illustration on this page.

General goods, crated or at all events packed, and possibly perishable freight, are normally handled at this depot. "Rough" loads such as coal, bricks and timber are dealt with "outside"

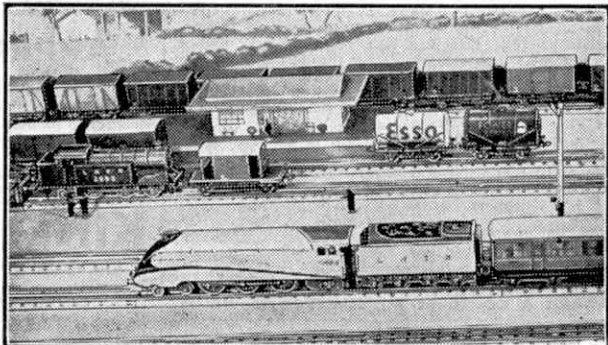

Shunting operations at a local yard. The Dublo Tank Locomotive is a handy unit for this purpose.

BARGAIN DISCOUNT APPROVALS

We offer a fine range of picked Modern and New Issues on approval from 1d.—6d. each. (Better selections also available). Generous discount and prompt attention. Br. Colonials or Mixed selections post free on request. (We do not send again unless requested). Current and Obsolete mint G.V.I and Coronations in stock. "Wants" lists welcomed for singles, but no single-country sheets available.

Postal Business Only

THE BIRKDALE STAMP CO. (P.T.S.)
104, LIVERPOOL ROAD, SOUTHPORT, Lancs.

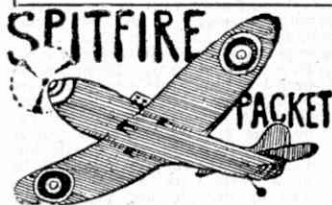

PACKET contains 30 air, triangular, and stamps with aeroplanes, etc.—2 LIBERIA triangular (with aeroplane); NIGERIA; F. OCEANIA; MOZAMBIQUE (Elephants); INDIA; 2 Canada; S. AFRICA (Pictorial); 2 TANGANYIKA; PALESTINE; BRAZIL (aeroplane design, etc.); 5 U.S.A.; ICELAND (Fish); Australia; CAYMAN IS. (Pictorial); NEW CALEDONIA; CAMEROONS; ST. PIERRE; MOZAMBIQUE (Pictorial); MADAGASCAR; PHILIPPINE IS.; CEYLON (Pictorial); EGYPT; JAPAN (Emperor). Price 5d., post 2d. extra. Applicants for approvals receive 6 Pictorial S. Africa and in addition, those sending addresses of stamp collecting friends get set of 4 JAMAICA BARGAINS—100 B. Cols. 2/6; 12 Free French (Cols.) 9d.; 20 Rhodesia 1/6. ASK for LISTS 1d. H. C. WATKINS (MM), Granville Road, BARNET

COUNTRY and SPECIAL PACKETS

20 different Air Mails 3/6	
20 Argentine ... 1/-	100 France ... 4/6
10 Brazil ... 8d.	25 Italy ... 1/-
25 Bulgaria ... 1/6	50 Luxembourg 5/-
50 Bulgaria ... 3/6	25 Roumania 1/3
15 Cape Verde ... 1/3	25 Soviet Russia 1/9
Postage 2½d. extra on all orders, or post free with approval selections.	

CAPT. M. CAMPBELL & CO. (Dept. MM)
15, North West House, West Street, Brighton

THE BOMBER AND SUBMARINE PACKET FREE!



One of the most interesting pictorial stamps ever issued is included in this wonderful packet of good stamps. It depicts a Wellington bomber attacking a German submarine in the Atlantic. Other stamps include Australia (late issue), Eire, obsolete foreign, portrait King Victor Emmanuel, large Belgian Railway issue, Czechoslovakia, old French Republic, U.S.A., and finally a pair of unused issues overprinted with new value, and to the first 500 applicants, a beautiful large unused French "De Gaulle" issue. The whole collection absolutely free to all collectors sending 3d. for postage and requesting approvals.

LISBURN & TOWNSEND LTD.

(MM), 41, Norton Street, Liverpool 3. Tel. 299 North



FREE to all
STAMP COLLECTORS
SENDING
2½d. POSTAGE
NEW
COMMEMORATIVE
from ZANZIBAR

G. P. KEEF
WILLINGDON
EASTBOURNE

1944 HEALTH



Globe-Trotter offers you this month one of the NEW ZEALAND 1944 Health Stamps FREE together with ZANZIBAR 1944 Large Pict. Commem. This amazing FREE GIFT will be sent to all applicants for a Globe-Trotter Approval Selection and enclosing 3d. stamp.
Globe-Trotter, 70, West Ave., B'ham 20

THE FIRST STAMP EVER ISSUED

(British 1840 Penny Black) for P.O. 7/9! It is guaranteed genuine in every respect. (Better-grade copies also available at 10/6, 15/6 and 20/- respectively). Its companion stamp (1840 2d. blue) nice used at 10/- (better grade at 14/6, 17/6 and 22/6 respectively). Other "Classics" which every collector should have are the CAPE OF GOOD HOPE TRIANGULARS; we offer 1d. rose (cat. 45/-) at 17/6; 1d. brown-red (cat. 57/6) at 20/-; 4d. blue (cat. 20/-) at 10/-; 6d. pale lilac (cat. 45/-) at 17/6; 1/- yellow-green (cat. 90/-) at 32/6; 1/- deep dark green (cat. 90/-) at 33/6; and 1/- emerald-green (cat. 47) at 52/6; also VICTORIA 1850-55 Half-Length Queen 1d. (cat. to 70/-) at 10/- (fair) to 25/- (very fine); and 3d. (cat. to 50/-) at 7/6 (fair) to 17/6 (very fine); 1854-55 Queen on Throne 2d. (cat. to 25/-) at 5/- (fair) to 12/6 (very fine).

SUPERB APPROVALS (general, or by countries for really serious collectors and specialists) against approved English references or a deposit.

Current price list 1d. post free.

NORRIS & CO. (Dept. M), SOMERCOTES, DERBY

FREE—STAMPS CATALOGUED 5/-
to applicants for 1d. approvals.

COX, 17, STONELEIGH PARK ROAD, EWELL

For other Stamp Advertisements see also pages 140 and viii.

APPROVAL BOOKS

containing low and medium priced Colonial and Foreign stamps still sent to applicants. Good discount and a list of 90 FREE GIFTS varying in value according to money sent for purchases. These gifts can be chosen by you from this list which contains King George VI Jubilees, Free French, ALL the Coronation Sets Mint, etc. 3d. stamp please.

C. A. RUSH, 38, Queen's Avenue, Whetstone, London N.20

KING GEORGE VI

A fine packet of unused British Colonials of the present reign from the Cayman Islands, Cyprus, Grenada, Dominica, Malta, Kenya and Uganda, also Southern Rhodesia Jubilee sent free to all applicants for approvals enclosing 2½d. postage.

R. D. HARRISON, ROYDON, WARE

Stamp Collecting

Currencies on Stamps

By F. Riley, B.Sc.

LAST month I dealt with inscriptions on stamps as a guide to their identification. There are countries whose names as given on their stamps differ greatly from their English equivalents, and it is worth while adding some of these to our list. For instance, "Ceskoslovenska" is our Czechoslovakia; "Eesti" appears on the stamps of Estonia, and "Escuelas" on those of Venezuela. Three examples that have probably become more familiar to us since the outbreak of the war are "Ethiopia," which



we know as Abyssinia, "Grand Liban" for Great Lebanon, in Syria; and "Helvetia" for Switzerland.

Another example that collectors now know well through the issue in this country of Polish stamps is "Pocztą Polska" for Poland. The country name on the stamps of Albania is "Shqypare" or "Shqipni," both quite different from the English version, and a similar wide difference is provided by the stamps of Finland, on which the name of the country appears as "Suomi."

Knowledge of the names and have already given will go a long way towards identifying strange stamps, but there is another valuable aid in the currencies, which indeed should be known to stamp collectors if only because the value of a stamp is one of its two most important features. There have been stamps without any values on them, but these are very rare indeed. One example that comes to mind is the result of an oversight. A few stamps of one of the interesting series that appeared in 1943 in the French Somali Coast, of which Djibouti is the capital, found their way into circulation with a blank space where the value should have been. Readers will remember this stamp, which was illustrated in the "M.M." at the time of its appearance. A locomotive forms the principal feature of the design, presumably because Djibouti is the beginning of the railway from the coast of the Red Sea to Addis Ababa, the capital of Abyssinia. Other examples of stamps without values come from Portugal, and in this case the omission was deliberate, for the stamps were provided specially for the use of Red Cross and other societies.

These are exceptions to the general rule, and the importance of the value on a stamp is illustrated by such issues as the first of Brazil, the famous "Bull's-Eyes," which have little more on them than



the number of reis they are worth for postal purposes. Official and postage due stamps of many countries, including Great Britain, conform to the same idea. The value is by far the most prominent feature of these stamps, perhaps to impress on the recipient of an unstamped letter the enormity of the crime committed by his correspondent!

German stamps issued after the last Great War, at the time when the value of the mark fell with great speed to almost nothing, also have little more on them than the number of marks they represent. The printing presses found it almost impossible to keep pace with the demands for stamps of higher denomination as prices went higher. All thought of elaborate design and so on was abandoned, and as the race went on new values were provided by simply printing new numbers in black on existing stamps. This went as far as the issue of stamps valued at millions of marks, as in the example illustrated on this page.

Currencies on stamps are often picturesque as well as useful aids to recognition. A good example is provided by Siam, on the stamps of which we get slots, atts, sio, sik, salung, ticals and bahts, a splendid variety! From China we get candarins and taels, and from Mongolia mungs and tubriks. Of European countries the most interesting cases are provided by Balkan countries. In Greece and Crete we have lepta, 100 of which make up one drachma; in Bulgaria the corresponding currency names are stotinki and leva; in Yugoslavia paras and dinar, and in Rumania bani and leu, in each case 100 of the first named being equivalent to one of the second. This 100 to 1 relationship holds good in many countries. For instance, in Hungary we have 100 filler to one krone, and in Poland 100 groszy to one zloty; while in Finland there are 100 penni in



a Finnish mark. Russian kopecks and roubles are well known to stamp collectors nowadays. The appearance on stamps of ore points to Norway, Sweden and Denmark, while the aur of the stamps of Iceland is clearly derived from the same source; in each case 100 make up either 1 krone or 1 krona. Nearer home we have the cents and francs of France and Belgium, the cents of Holland, 100 of which go to the gulden, and the pennings and marks of Germany.

One or two further examples may be given of picturesque currencies, not perhaps the equal in variety of that of Siam. From Estonia we get senti, of which there are 100 to 1 kroon. In Latvia the corresponding names to know are santimi and lat, while in Lithuania 100 skatiku make up one auksinas. Abyssinia provides us with the guerche, of which there are 16 to the taler.

The same currency is shown on most of the stamps of Latin America, 100 centavos making up 1



(Continued on page 142)



FREE SYMBOLIC PACKET

Get this fine packet of Symbolic Stamps **ABSOLUTELY FREE** to add to your collection. It contains commemorative U.S.A. stamp inscribed "Win the War" and showing the "V" for Victory (Symbol of the Allies) and is catalogued 6d. The GERMAN stamp shows the Swastika (Symbol of the Nazis) and was issued for use on Official Nazi Government letters only. This packet of scarce and interesting stamps will be sent to you **ABSOLUTELY FREE** if you ask us for Approvals and Price List and send us 3d. for postages.

THE WINDSOR STAMP CO. (Dept. M), UCKFIELD, Sussex

8 LIBERATED COUNTRIES



Stamps from 8 European countries liberated by the Allies. Free to all applicants enclosing 3d. to cover postage and applying for our famous approval sheets.

ERRINGTON & MARTIN

Dept. No. 412, South Hackney, E.9

K.G.VI SETS to 1/- Cash with Order - Post Extra

At 2/10 each — Antigua, Montserrat, St. Kitts, St. Lucia, St. Vincent, Virgin Is.
At 2/11 each — Ascension, Basuto, Bechuana, Cayman, Dominica, Grenada, Swazi.
3/7 Bermuda. 4/- Falkland. 3/- Fiji.
FULL LIST FOR 1d. STAMP. ALL MINT.

GEM STAMP CO.

1729, London Road, LEIGH-ON-SEA, Essex

SUBSCRIBE NOW

All medium collectors are strongly advised to subscribe to the Monthly Bulletin of British Colonials. Modern colonials in scarce supply and K.G.VI (current and obsolete issues) are included at moderate prices.

DO NOT DELAY. SUBSCRIPTION 1/- per annum.

THE BELFAST STAMP SERVICE

67, Ashley Avenue, Belfast

FOREIGN STAMPS

BOUGHT AND SOLD — HIGHEST PRICES GIVEN
FOYLES, 121, Charing Cross Road, W.C.2

FREE! 10 WAR STAMPS FREE!

Free to all applicants who send 2½d. for postage and ask to see a selection of my "WORTH WHILE" approval sheets. Good stamps at cheap prices.

JOS. H. GAZE, 10, Pimlico Road, CLITHEROE, Lancs.

STAMPS worth having, 25 Free to applicants for my famous Stamps, Sets and Singles, Includes Virgin Is., St. Helena, Bermuda, Mauritius, Bechuanaaland. Without approvals, 9d.
S. H. FLEMING, Newhaven, Glyn Avenue, COLWYN BAY

For other Stamp Advertisements see also pages 138 and viii.

BARNET & FORD

The Stamp Shop, 5b, High Street, CONWAY, N. Wales

CANADA. War Issue 16c, Air-Express, f.u. 5/-.

(The finest Air-mail stamp issued).

EGYPT. 1937 Farouk Investiture set, comp. f.u. 1/6.
1939 4 vals. (Farouk and Mosique) f.u. 2/6.

INDIA. Geo. VI R.1—R.10 (4 large stamps cat. 10/9) 2/3.

IRAQ. 1941 5 pictorial stamps mint 1/-.



The "CAPTAIN COOK" Pkt. FREE! Grand stamps commemorating that "Hero of the South Seas," Capt. Cook (1728-79), incl. fine Cook Is. (as reduced illus.), his Sailing Ship Endeavour, with Chart also Landing of Capt. Cook, etc. Just send 3d. postage for this grand romantic packet, and ask to see special "Mercury" Approvals.

Philip J. Dyke (P.T.S.), 35, Buckleigh Ave., London S.W.20

NEW ZEALAND

S.G. Simplified Cat. Numbers. Postage extra.

Mint marked *. S.A.E. appreciated.

1d. ea.: 28, 29, 45, 64, 69, 73, 74, 87, 88, 89, 91, 93, 112, 144, 145, 147, 177, 178, 178A, O11, O12, O20, O24, O30, O46, O47, O47A, D13. 2d. ea.: 27, 46, 47, 60, 62, 104, 106, 107, 177A, 183, 184, 186, O21, O23, O24, O49*, O50, O52. 3d. ea.: 18*, 18, 44, 95, 98, 105, 149, 150, 179, 179A, 183*, 204*, 207*, 208*, O22, O36, O48A. 4d. ea.: 76, 80, 97, 103, 111, 152, 162, 173, 198, O13, O38, O48. 6d. ea.: 30, 32, 34, 50, 128, 151, 154, 155, 158, 161, 165*, 167, 168*, 188, 199, 202*, 233*, 205*, O29, O35, O37, O41, O51*, L17. 9d. ea.: 36, 129, 166*, 168, 174*, 185*, 185, 189, 200*, O33, O53*, O54, O55. 1/- ea.: 130, 153, 180, 191, 201*, O42, O43, O56, O57. 7/6 ea.: 65*, 66*, 120. 1/6 ea.: 48*, 156, 172, 175, 176, 187, 195, 206*, O58*, O59. 2/6 ea.: 157, 164, 190, O44. 3/6 ea.: 171*, 193. 6/- ea.: 137. 15/- ea.: 163. Pkts., all different, 50 for 2/6, 65 for 5/-, 90 for 10/-, 120 for 20/-.

Your "Wants" lists would be appreciated.

Approvals sent against references.

F. Harlow (B.P.A.), 133, Bradbourne Vale, Sevenoaks, Kent

Write to-day for British Colonial Approvals 1d.—6d. single items, also Coronations and short mint sets. Postage 2½d. Purcell, 22, Green Lane, Amersham, Bucks.

HALF PRICE APPROVALS

We are offering until further notice special books of BRITISH COLONIALS incl. CORONATIONS and K.G.VI issues, also EUROPEAN and other FOREIGN

at 50% DISCOUNT

Minimum purchase, 10/- worth for 5/- net.

Send 5/- DEPOSIT for choice selection.

SAUNDERS & CO., 51, Draycott Avenue, HARROW

Stamp Gossip

and Notes on New Issues

By F. E. Metcalfe

IN peacetime, a number of collectors preferred foreign stamps to British Colonials because, as they put it, there was more doing with the former than the latter. That doesn't apply to-day, for collectors of colonial stamps of the current reign are surely getting all the fun they need in the way of varieties, colour changes, etc. In one week recently the writer received letters from three Colonies, or rather two Colonies and a Dominion, and each contained news of a stamp that is probably being dropped. If the information proves correct the stamps in question will prove quite good items, which is the reason why it is being passed on.

The first letter dealt with the 5d. value of Gambia. This has always been a bit of a mystery stamp ever

since it came out in 1941. Very few were used, and after a time it went off. There was another printing in 1941, but whereas the stamp could be obtained by dealers from the Crown Agents in London, used copies with genuine postmarks were rarely seen. Readers were recently warned

about copies with forged postmarks. There was very good reason for this warning, but mint or used this will be a very good stamp, if it is actually obsolete, and it appears to be.

The second letter mentioned the 1/5 stamp of Fiji. This odd value was issued for airmail postage, but apparently it fits into no postal rate now, and it is not to be wondered if the value is going out. At the moment the Crown Agents have supplies, but these will no doubt have melted by the time these words appear in print. Still a copy should be obtainable for the time being at about 2/-. It will be worth buying at this price.

The third stamp is mentioned with all reserve, for there is no confirmation of the information about it from any other source.

Anyhow my correspondent stated that the 9d. value of Gold Coast was not to be reprinted. All dealers can testify how scarce this stamp is used. Gibbons' catalogue it at 1/6 thus. This price is not out of the way for a nice copy, and no harm can be done by picking one up, just in case.

It will be remembered that the handsome set of line-engraved stamps issued in London in June of last year for

the Free Dutch Government was for use on Dutch ships. It was stated at the time of issue that when Holland was again free these particular stamps would be placed on sale there. News is now to hand that this plan has already been carried out and these stamps are already being used in the liberated parts of Holland. Used copies with Dutch



postmarks, as distinct from the so-called used which are on offer just now, will be much sought after by collectors in Great Britain, but with mails so scarce from Free Holland most collectors will probably have to be content with mint copies.

One of the most popular of the "hardy annual" sets in the piping days of peace was the "Pro Juventute" issue of Switzerland. These stamps have been appearing regularly since 1913, but for some

time now it has not been possible to import any, owing to currency restrictions, and collectors have had to be content with any odd copy that might come their way. These have been few and far between, and in consequence it has been difficult to get together a complete set of four issued during any of the war years. This is a pity, for the stamps have latterly been more beautiful than ever.

The set issued at the end of last year consisted of the usual four values. The lowest value featured that most over-rated of all flowers, the edelweiss; the second the turks-head lily; the third the columbine, illustrated on this page; and the top value showed a picture of the Swiss statesman Numa Droz, who was born on 27th January 1844, of humble parents, and at the age of 32 became a Federal Councillor. Later he was made the President of the Federal Council. Droz was one of the few men with enough courage to tick off the great Bismarck. Altogether a worthy citizen of a worthy country. What fun British collectors are going to have after the war picking up these beautiful war issues, which are not likely to be expensive.

Like the rest of Europe, France continues to turn out new stamps by the minute, and some are quite irresistible. We are illustrating a copy of the "Liberation" stamp. This is just one of the many finely designed stamps that are appearing in France. What pitiable objects those produced in London for the French Colonies look when placed alongside stamps like these. In contrast we are illustrating a crude effort from Spain. This is one of several values recently emitted for charity. Surely no charity deserves so ill an effort.

One stamp which we should have liked to illustrate this month—maybe we shall be able to do so later on—would have been one of a set issued by Venezuela, of all countries, to commemorate the centenary of the first co-operative society, the "Pioneers" of Rochdale, Lancashire. What a commentary on the supine attitude of our own postal authorities! All British collectors can do is to thank the postal authorities of Venezuela for doing the work we should have been glad to do ourselves.

Readers should look out for the new Australian commemorative, in three values, with portraits of the Duke and Duchess of Gloucester. The set will remain current for only three months.

And the tip for the month? Well, a nice little stamp within the reach of all is the obsolete 1d. red, G. VI issue, of Barbados, mint Perf. 13½ x 13, or even Perf. 14.



Welding in Post-War Reconstruction—*(Continued from page 111)*

the job took only a week, and the owners have had no more trouble with the machine.

Mobile welding plants of this kind are constantly in employment for the repair of land and marine boilers. Graphic stories have been told of work done by skilled operators with this type of plant on Tank Landing Craft on French beaches. Often it was an exciting race between welding and the fast rising tide. The welders won and the T.L.C. were saved.

Fig. 2 (on page 111) shows a casting weighing over six tons. It is a 60 in. boring mill. The large vertical flange at the top was broken off, and in addition two cross slides—not shown in the picture—weighing 1½ tons each, were also broken. The owners were faced with the alternatives of a new casting or a repair by scientific welding. A replacement would have required many man-hours of work in foundry and machine shop, and a demand upon the national metal resources; so it was decided to repair by welding. The work was carried out in the Barimar Welding Works with complete success, as shown in Fig. 3 on page 111, and brought the owners a saving of hundreds of pounds.

Driving a Diesel-Electric Locomotive—*(Continued from page 112)*

like a good car. But remember it takes years of experience before you can judge your distance as neatly as Jim over there on Number Three, and a novice can easily pull a drawbar clean out of the end of a wagon.

Well, time's up. You want to stay longer? You can stay for a whole week if you like, for there is enough fuel in the tanks when they are full for 140 hours shunting, and this engine only visits the Running Shed once a week. Then you should see her scuttle down the line to the Depot at top speed, which is only 15 miles per hour, for, as you know, a shunting engine is very low-g geared. So long!

Have you ever thought about this?—*(Continued from page 119)*

pallet, and enables the pallets to move freely. It is called the drop, and when it occurs, the escape-wheel really jumps forward unchecked until brought to a halt by the next tooth to act falling sharply on its pallet. This impact at the end of the drop makes the sound known as ticking. The amount of this drop is kept as small as possible, for although it gives the clearance necessary for the escapement, it represents lost motion and power. In a good escapement, the drop will only be one degree, or less, at each release of a tooth, and it is remarkable that this tiny free movement of the escape-wheel can make a ticking sound which is heard for a long distance.

Most clocks tick, but their escapements are not all exactly alike. Pendulum clock escapements are of the types known as the recoil, dead-beat, pin-wheel and gravity, the latter being the most interesting. It was invented for the great Westminster clock, and is now used for nearly all large turret clocks. Before it was introduced, wind and weather used to upset the time-keeping of large clocks with exposed hands by varying the impulse to the pendulum. The gravity escapement cleverly overcomes this by making the escape-wheel lift and lock two weighted arms. As the pendulum swings, it unlocks each arm in turn and the arms then fall back with the pendulum, giving an impulse by their own weight, which is, of course, always the same. As each arm descends the other is raised, ready for the next impulse, and this gives the gravity escapement a rather unusual tick. Escapements using balances are very similar to those with pendulums. They are known as the lever, chronometer, cylinder, and duplex. The chief difference is that, as the balance works independently of gravity, they can be used in any position. Their tick is produced in the same way as in a pendulum

escapement, but is usually faster. Watches often make 18,000 ticks per hour, mantelpiece clocks about 7,200, and old grandfather clocks 3,600, or just one per second.

Facts about Steel—(Continued from page 125)

From what has been written, it should be obvious that a cold-worked metal such as steel is stronger and more resistant to deformation than the unworked material. It must be remembered, however, that cold work may injure the corrosion resistance of the nickel chromium stainless steels.

The heat-resisting steels are actually an extension of the range of stainless steels, which latter are themselves to some extent heat-resistant, but not so much so as the heat-resisting steels proper. It is known that the effect of heat on metal is to increase its tendency to oxidize or "scale"; as the result of the combination of oxygen in the furnace atmosphere with the iron. It also lowers the mechanical strength of the steel. The heat-resisting steels are "stainless" as well as heat-resistant, but their great feature is that not only do they resist scaling and oxidation at temperatures over 1,000 deg. C. up to about 1,150 or 1,200 deg. C., but they also retain a proportion of their mechanical strength at these elevated temperatures.

They are thus most useful and important to the engineer, because they enable him to employ parts made of steel for certain items of plant and equipment that will, he knows, be called upon to withstand heat. Parts of furnaces, such as dampers, doors, burners, firebars, are examples; but in addition a whole range of items in the construction of chemical plant can be made in heat-resisting steel with marked advantage.

It will thus be seen that the casual discovery made by Brearley in 1913 has led to a vast ramification of stainless steels, and the general effect of their introduction has been to save labour for the housewife and the engineer, to improve modern engineering by giving it materials capable of meeting hitherto impossible requirements, and to brighten our cities with the gleam of a stainless metal, as those who have seen New York will realise.

Stamp Collecting—(Continued from page 139)

one peso, but there are one or two interesting exceptions. Thus in Ecuador the peso is replaced by the sucre, while in Panama the European discoverer of the Pacific was honoured by having currency named after him, with the result that on this country's stamps since 1906 we find *contesimos de balboa* and the *balboa*, 100 of the former to one of the latter. In Uruguay the real of 100 centavos has been used, although the peso appears on most of this country's stamps of high value. The most notable exception, however, is furnished by Brazil, and the point shows how stamps illustrate history. Brazil was colonised by the Portuguese, and accordingly we find that the currency is Portuguese in type, the basis being the reis, just as in Portugal until 1918, when the escudo of 100 centavos came into use.

BACK NUMBERS OF THE "M.M."

A few copies are available of each of the following issues of the "M.M.," price 8d. each, including postage, etc. Orders should be sent to Publishing Department, "Meccano Magazine," Binns Road, Liverpool 13, with the necessary remittance by Postal Order or in stamps.

1943 October

1944 April

1945 January, February, March

**COMPETITION RESULT
OVERSEAS**

April "Doublets" Contest.—1st Prize: P. Tasker (Miss), East Malvern, S.E.5; 2nd Prize: G. Stokes, Port Elizabeth; 3rd Prize: M. Munro, Woodville, N.Z. Consolation Prizes: A. W. Denber, Cairo; E. A. Jones, Auckland.

Competitions! Open To All Readers

What are these Engine Names?

Competitions in which entrants have to discover ingeniously hidden or disguised locomotive names are attractive to "M.M." readers, and here is one of a type that has proved particularly popular. In the centre of this page is a panel giving the remains of 12 names of locomotives. These names were first printed in full and then a portion of each letter was removed, so that none of the names can now be read at a glance.

The locomotives represented by these fragments are all well known, and railway enthusiasts should have no difficulty in solving the puzzle. Even those who are not familiar with the names of locomotives will be able to make good in this competition, for a little ingenuity will enable them to "spot" the letters of the various names and thus to fill in the vacant portions. All that competitors are asked to do is to make a list

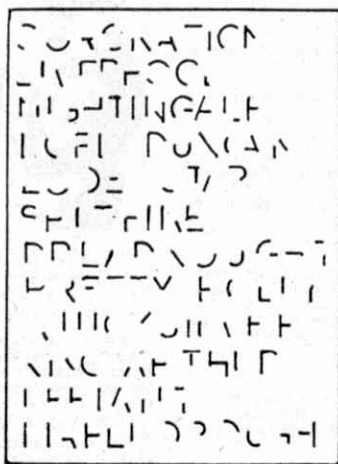

of the 12 names in full, adding in each case the name of the company to which the locomotive belongs, its class, and its number.

There are the usual two sections, for Home and Overseas readers respectively, and in each there will be prizes of 21/-, 15/- and 10/6 for the best entries in order of merit. In the event of a tie for any one prize the judges will take the neatness and the originality of the entries into account in making their decision. A number of consolation prizes of 2/6 each will also be awarded. All competitors should make sure that each sheet submitted has on the back the sender's name, full postal address and age. Envelopes should

be addressed "April Names Puzzle, Meccano Magazine, Binns Road, Liverpool 13." The Closing date in the Home Section is 31st May; that in Overseas Section is 30th November.

Prizes for Ship or Boat Drawings

In our December 1944 issue we announced a Transport Drawing Contest in which competitors were asked to submit drawings of either a train, tramcar, trolleybus or motor bus. Judging by the exceptionally large number of entries received, this contest proved very popular, and we have decided therefore to give budding artists another chance to show their capabilities by arranging a further drawing contest. Again the competition is concerned with transport, but this time by water, for the subject chosen is shipping.

In this contest entrants are asked to submit drawings of boats or ships. The type of vessel pictured is left entirely to the competitor; it can be anything from a rowing boat, barge or coble to a pre-war luxury liner, a battleship or an aircraft carrier, and those whose thoughts turn to landing craft, buffaloes, amphibious jeeps and other craft used in the present war are at full liberty to enter representations of their favourites.

As usual in these competitions there will be separate competitions for Home and Overseas readers, and in each of these there will be two sections, A for competitors of 16 years of age and over, and B for competitors under 16 years of age. Prizes of 21/-, 15/- and 10/6 will be awarded to the competitors in each section whose drawings are considered to be the best, and consolation prizes also will be

awarded. Entries should bear the sender's name, full postal address and age on the back. Competitors are particularly requested not to put their names on a separate sheet of paper.

Envelopes containing entries should be addressed "April Drawing Contest, Meccano Magazine, Binns Road, Liverpool 13," and should be posted to reach us not later than 31st May in the Home Section and 30th November in the Overseas Section.

April Photographic Contest

This month's photographic contest is the 4th of our 1945 series, and in it, as usual, prizes are offered for the best photographs of any kind submitted. There are two conditions—1, that the photograph must have been taken by the competitor, and 2, that on the back of the print must be stated exactly what the photograph represents. A fancy title may be added if desired, but entries on which the conditions stated are not observed will be disqualified.

Entries will be divided into two sections, A for readers aged 16 and over, and B for those under 16. They should be addressed: "April Photo Contest, Meccano Magazine, Binns Road, Liverpool 13." There will be separate sections for Overseas readers, and in each section prizes of 15/- and 7/6 will be awarded. Closing dates: Home Section, 30th April; Overseas, 31st October.

Fireside Fun

"One, two; one, two; one, two—" roared the sergeant as the awkward squad went through the beginnings of their drill."

"Goodness," exclaimed a watching boy. "Have they to teach those ignorant fellows how to count."

"I want to make sure that nobody is late in future," said the foreman sternly. "Now what can we do about it?"

"That's easy. Let the last man in blow the whistle."

Manager, paying Jones his salary: "These notes are a bit grubby. I hope you are not afraid of microbes, Jones."

Jones: "Not at all, sir. They couldn't live on my salary."

Customer: "I have a fine canary, but I can't make it do any tricks, while you can get yours to do anything. Now why is that?"

Dealer: "It's just a matter of brains, sir. You have to be better off for them than the canary."

"You look miserable for a man who has just won £1,000 in the sweep, Sandy. What's the matter?"

"Weel, I had twa tickets, an ane o' the twa is just deed loss."

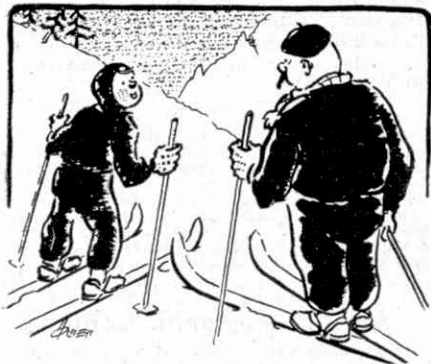

"No Son, nothing's impossible."

"Did you ever try getting through a revolving door on those things, Dad?"

Policeman: "Why did you hit this Chink with that vase?"

Prisoner: "He threatened me in broken English, so I retaliated in broken China."

THIS MONTH'S HOWLER

An epistle is the wife of an apostle.

BRAIN TEASERS WHICH GOES FARTHEST?

We start off this month with what to most readers will be a startling question. During a run, which wheel of a bicycle travels the greatest distance? To those who think the question ridiculous all that we can say is "Think again."



"Well you see 'is 'ead is so far removed from 'is body that a long neck's absolutely necessary."

OVERLAPPING WORDS

Below is a representation of a 16-letter word, a made-up one that means nothing and consists of a series of three-letter words, every letter in run except the last two beginning one of these words, so that there are 14 of them altogether.

H X X H X X X G X X X W X X X K

Five of the actual letters are given to make the task easier. Each of the missing letters is represented by a cross. What are they?

Making up weird words in this way is a good game; it is not easy to concoct long ones, but perhaps some reader can make one up with more than 16 letters in it.

ONE POINTER WANTED

Here is a simple problem, to the solution of which one clue points directly and easily. Two equal sums of money, £A/AF/AE, had to be paid, and the total sum paid over was £B/AD/F, each letter in these amounts representing a figure. What were these sums?

FIND THE FLAW

What was described as an ancient document professing to be a will was brought to a dealer. It began: "This is the last will and testament of James Adolphus Holles, Cambridge" and it ended with the words: "Given under my hand this tenth day of February in the year 1635 in the reign of our most gracious majesty King Charles the First." The dealer read it, laughed and returned it, saying that it was not genuine. Why did he do this?
B.H.

SOLUTIONS TO LAST MONTH'S PUZZLES

How 18 dots can be arranged in eight lines of five dots each is shown in the attached diagram, on which both dots and lines are marked.

In our second problem it is easy to see that there must be 200 beans to each plant, as every bean grows into a plant. It is clear then that there must be five beans in each pod and 40 pods on each plant in order to make up the number of 200.

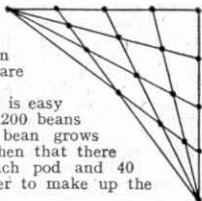

BOND'S

We will again be able to supply all the requirements of the Model Maker when the war is over and many new items are now, on the drawing board getting ready for the time when we can put them into production together with all our other well-known specialities.

We can supply small quantities of materials, screws, rivets, gears and tools, etc., so we will be pleased to know what you are requiring.

No catalogues are available now.

We will be pleased to purchase any models in good working condition. Kindly send full particulars and price required.

BOND'S O' EUSTON ROAD LTD.

Est. 1887.

Phone:

EUSTON 5441-2.

**357, Euston Road
LONDON N.W.1**

Study for a VICTORY VOCATION NOW!

Radio-Communication, Television, Radio-location, etc., will play an ever-increasing and important part in post-war developments. Britain leads the world in this scientific and far-reaching field and there will be an ever-widening range of brilliant careers ahead for new entrants.

Specialised training for appointments in all branches of Radio is available at The Wireless Colleges.

NEW
TERMS
MAY
AND
SEPT.

- Boarders accepted in both Colleges
- Licensed by H.M. Postmaster General
- Organised Sport at both Colleges
- Own Swimming Pool
- On Air Ministry List
- Most modern and complete equipment
- Low Fees

For Illustrated Prospectus send 2d. stamp to
The Principal of the Colwyn Bay College

WIRELESS COLLEGES

CALMORE, SOUTHAMPTON or
COLWYN BAY, N. WALES



When Peace comes

The technical skill which has enabled us to produce a vast amount of electrical and mechanical equipment for the Forces will be devoted to the production of

**High-efficiency
ELECTRICAL, SCIENTIFIC
AND MECHANICAL MODELS**

including
**Electric Motors & Dynamos
Electrical Outfits, Transformers
Stationary Steam Engines
STUDENTS' MICROSCOPES
TELESCOPES, etc.**

All electrical, scientific, and mechanical models will be made to the highest specifications and subject to the same rigid inspection as our war-time products. Our plans are well advanced and production will begin as soon as the necessary materials and labour are available.

SIGNALLING EQUIPMENT LTD

Merit House, Southgate Road
Potters Bar, Middlesex

Telephone:
Potters Bar 3133/4

Cables & Telegrams:
"SEL, Potters Bar"

LINESIDE FEATURES:	"00"	"0"
NEW STATION SEATS	1/3	1/3
OIL TANK STORAGE	15/6	—
COTTAGES	6/-	9/6
STATION SEAT AND TIME TABLE BOARD	3/6	3/6
COAL OFFICES	4/-	5/6

BOOKS:

Postage extra.

- L.M.S. "TITANS OF THE TRACK," 1/6, by post 1/8.
- "THE MCINTOSH LOCOS. OF CALEDONIAN RLY.," 3/6, by post 3/9.
- "A.B.C. OF L.P.T.B.," 2/-, by post 2/2.
- "MODERN LOCOS. AND ELEC. TRACTION OF S.R.," 1/6, postage 3d. extra.
- "CARDBOARD ROLLING STOCK AND HOW TO BUILD IT," 2/6, by post 2/9.

TYLDESLEY & HOLBROOK

109, Deansgate, Manchester 3 'Phone: Bla' 7312

Large stocks of Mechanical and Engineering Textbooks.

FOYLES FOR BOOKS

New and second-hand books on all subjects.
BOOKS BOUGHT.

119-125, Charing Cross Road, London W.C.2
'Phone: GERrard 5660 (16 lines). Open 9-6 (inc. Sats.).

CIGARETTE CARD COLLECTORS!

Send for the 1944-45 list of 500 different series. Nearly 20,000 different cards. Price 4d. (Govt. order). Current Bargain List 1d.

Cards Purchased. I pay high prices for all kinds in perfect condition. Old or modern, large or small, complete sets or accumulations. Especially Required. Modern Players, Wills, Gallaher, Phillips, Ardath, Carreras, and Ogden cards. Send parcels for immediate cash offer.

R. W. HOUSTON, BCM/EXCHANGE, LONDON W.C.1



MANUFACTURE SUSPENDED UNTIL AFTER THE WAR

ELECTRADIX Special Offers!

HEADPHONES. MOVING COIL P.M. 45 ohm., $\frac{1}{2}$ in. coil, $1\frac{1}{2}$ in. overall, in bakelite case with 3 in. front flange. Coil is energised by the famous ALNI Magnet. These units also make excellent speech mikes, or, with a matching transformer they can be used as a miniature loudspeaker. No headbands available. Price per pair, 24/-, or 12/6 for one unit. This is one of the finest Electradix Bargains ever offered.

SMALL D.C. MOTOR GENERATORS by E. D. C. and others. Pocket size for use in receivers to take the place of H.T. Battery, will drive off 12 volt accumulator, output 230v. 30mA. Beautifully made for Government radios. In new condition, 75/-.

HAND MIKES, for announcers, broadcasters and recorders, hand type, by Tannoy; multi-cell carbon type, weather-proof, for outdoor use or for Hall; has neat switch in handle, 21/-.

MAGNETS. Midget ALNI perm. steel disc magnets, $\frac{3}{8}$ in. dia. with centre hole. $\frac{3}{8}$ in. dia., of tremendous magnetic force; unlimited uses, 3/6 each. Horse-shoe permanent steel magnets, various sizes from 3/- each.

For other bargains see previous advertisements of

ELECTRADIX RADIOS

214, Queenstown Rd., Battersea, London S.W.8

Telephone: Macaulay 2159

35 mm. Films. All description from 6/-, Baers, 176, Wardour St., London W.1. Hire Programmes 10/-.

THE "DANDY" TOY PISTOL

complete with 3 wood shells, price 2/6, by post 2/9. Also **THE "CHAMP" TOY CANNON**, complete with 3 wood shells, price 2/6, by post 2/9.

BRUCE JOHNSTON, Toy Stores, KEIGHLEY, Yorks.

SHIP KITS

An entirely New Range of Ship Kits, the finest value on the market. See the new shaped hull. Many fittings. "H.M.S. King George V" 7/6, "H.M.S. Warspite" 7/6, post 6d. each, "H.M.S. Mauritius" 6/6, post 6d. "Tribal Class" 5/6, post 4d.

In the near future many new ship kits will be available including Miniature Ship Kits. 1945 list ready soon. Send 3d. stamps.

GEORGE D. CAMPBELL

Dept. MM, 46, High Street, DUMFRIES

STUDY AT HOME FOR MATRICULATION

Wolsey Hall (Est. 1894) will coach you by post for London Matric., School Cert., Engin. Prelim., Lond. B.Sc. Degree, Teachers' exams, etc. Tuition continued free if you fail; low fees, instalments. PROSPECTUS FREE from Director of Studies, Dept. GK1.

WOLSEY HALL, OXFORD**"CARDBOARD ROLLING STOCK AND HOW TO BUILD IT"**

A book for every model railway owner! 2/6 from leading model shops or 2/9 post free direct; or send 2d. stamp for full details.

E. Rankine Gray, 726, Christchurch Rd., Boscombe, Hants.

A.B.C. LOCOMOTIVE BOOKS MAIL ORDER DEPT.
33, Knollys Road, S.W.16

Now available:
 Titans of the Track (L.M.S.) 1/8
 G.W.R. Locomotives ... 1/8
 London Transport Services 2/2
 Titans of the Track (S.R.) 2/2
 McIntosh Locos. Caledonian Rly. 3/8
 A.B.C. Wallers ... 1/11
 L.M.S. and L.N.E.R. Locomotives
 out of print. Instant Action (non-railway book) by Allan Macfarlane, 1/2. 24 pages of humour.

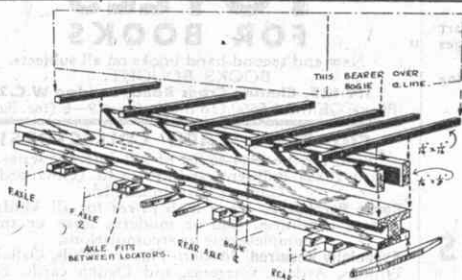

Exploded drawing showing undergear of a typical Wilson lorry.

WILSON LORRY KITS

THERE IS NO COMPARISON

4 mm. Scale — 00 Gauge

ILLUSTRATED CATALOGUE PRICE 1/-

Agents:

HAMLEY BROTHERS LTD.

200, Regent Street, London W.1

GEORGE D. CAMPBELL, 46, High Street, Dumfries

WILSON'S LORRIES LTD.

Dept. M, BRACKNELL, Berks.

Join the Well-Paid Ranks of the TRAINED MEN

MANY THOUSANDS MORE ARE URGENTLY NEEDED. PREPARE YOURSELF FOR A BETTER POSITION AND BETTER PAY

Ambitious men everywhere have succeeded through I.C.S. Home-Study Courses. So also can you. We

offer you the benefit of our 54 years' matchless experience as the creative pioneers of postal instruction.



If you need technical training, our advice on any matter concerning your work and your career is yours for the asking—free and without obligation. Let us send you full information regarding the subject in which you are specially interested. DON'T DELAY. Make "ACTION" your watchword.

The successful man DOES to-day what the failure INTENDS doing to-morrow. Write to us TO-DAY.

*Special terms for members of H.M. Forces
and discharged disabled members of H.M. Armed Forces*

YOU MAY USE THIS COUPON

(Penny stamp on unsealed envelope)

INTERNATIONAL CORRESPONDENCE SCHOOLS LTD.

Dept. 218, International Buildings, Kingsway, London W.C.2

Please send me the Syllabus of your Courses in.....

Name..... Age.....

Address.....



The I.C.S. offer Courses of Instruction in a wide range of subjects, including:

Accountancy	Hydraulic Engineering
Advertising	Joinery
Aeronautical Engineering	Journalism
Aero Engine Fitting	Machine Designing
Aero Fitting and Rigging	Machine-Tool Work
Aeroplane Designing	Marine Engineering
Air-Conditioning	Mechanical Drawing
Architecture	Mechanical Engineering
Architectural Drawing	Mine Electrician
Boilermaking	Mine Surveying
Book-keeping	Mining Engineering
Building Construction	Motor Engineering
Building Contracting	Motor Mechanic
Business Training	Moulding
Business Management	Plastics
Carpentry	Power-House Attendants
Chemical Engineering	Quantity Surveying
Civil Engineering	Radio Engineering
Clerk of Works	Radio Servicing
Colliery Management	Refrigeration
Commercial Art	Salesmanship
Concrete Engineering	Sanitary Engineering
Cotton Manufacturing	Secretarial Work
Diesel Engineering	Sheet-Metal Work
Draughtsmanship	Steam Engineering
(State which branch)	Structural Steelwork
Drawing Office Practice	Surveying
Electrical Engineering	(State which branch)
Engineer in Charge	Telegraph Engineering
Eng. Shop Practice	Telephone Engineering
Fire Engineering	Templating
Fitting and Turning	Textile Designing
Foundry Work	Toolmaking
Garage Management	Welding, Gas & Elec.
Gas-Power Engineering	Woodworking
Ground Engineer	Woolen Manufacturing
Heating and Ventilating	Works Engineering

And most of the Technical, Professional
and Matriculation Exams.

STAMP ADVERTISEMENTS

(See also pages 138 and 140)

NEW COLLECTORS START HERE

The Complete Mint K.G.VI Current Issues to 3d. from all the Colonies—ADEN to ZANZIBAR and including OBSOLETE.

(A) 72 diff. *(4d., 3d. and 1d. v.) 6/6. (B) 66 diff. *(1d. and 1½d. v.) 10/6. (C) 54 diff. *(1½d. and 2d. v.) 13/6. (D) 54 diff. *(2d. and 2½d. v.) 15/6. (E) 54 diff. *(2½d. and 3d. v.) 22/6; or Packets (A, B, C, D and E) 300 diff. *(4d. to 3d. complete) 65/-. (*or equivalent in cents.) /250 diff. Whole World 5/-, 300 diff. British Colonials 9/-. All post paid.

The Western Imperial Stamp Co., Trowbridge, Wilts.

3 Unused MAURITIUS FREE!

This attractive set will be presented entirely free to serious approval applicants. Only one gift to each applicant. Write to-day, and enclose 2½d. stamp. *Postal Business only.* 25 diff. Egypt 1/-, 15 Iraq 9d.

W. LE MERCIER, 58, LUMSDEN AVE., SOUTHAMPTON

STAMPS catalogued 6/6, 2/6, penny each! Approval, postage. J. Baguley, 22, Lawnsay, Romford.

FREE STAMPS TO ALL PURCHASING OUR BARGAIN PACKETS

1. N. Zealand 1944 Health Comp. given with 50 Brilliant Mint Br. Colonials for only 3/11 Post Free

2. 5 Scarce Foreign Mint given free with 40 Brilliant Mint Fr. Colonials for only 2/11 Post Free

3. 9 Used Egypt Farouk given free with 50 Mixed Foreign Used for only 2/3 Post Free

Send Postal Order to GOODE of 19, Clifton Rd., RUGBY

ISLANDS PACKET FREE

15 stamps from islands—Fiji (natives sailing canoe), Barbados (K.G.V.), Mauritius (K.G.VI), Ceylon (Colombo Harbour), Madagascar, Re-union, New Zealand, Eire and Jamaica (K.G.V and VI). Free only to those asking for approvals and enclosing 3d. postage—without approvals 10d. No stamps sent overseas.

HELY HUTCHINSON (MS)

Hurrock Wood, Kents Bank, Grange-over-Sands, Lancs.

BE A RADIO CONSTRUCTOR and get fine results by building tested and guaranteed designs. My constructional Data Sheets provide complete details, with fine prints and diagrams, which tell and show you how to make the Sets, etc. You cannot go wrong. DATA SHEETS for: High Efficiency Crystal Set, 1/6. Super Short-wave 2-Valve Set (Battery), 2/6. Three-Valve Med.-wave Set (Battery), 2/-; Two-Valve Amplifier (Battery), 2/6. Microphone, 2/6. Shocking Coil, 2/6. Please include stamp.

SPARKS' DATA SHEETS, 9, Phoebeth Road, Brockley, London S.E.4.

READERS' SALES AND WANTS

SALES

Four 2/- "Aircraft Identification" Books, Parts I, II, III and IV; also 40 "Valentines Aircraft Recognition" Cards. Offers.—Payne, "Hillcrest," Westerleigh, Nr. Bristol.

"Meccano Magazines," August 1939—December 1943; five missing; excellent condition, 30/-.—Ashworth, Spilsby, Lincs.

MECCANO MAGAZINE

Registered at G.P.O., London, for transmission by Canadian Magazine Post.

EDITORIAL AND ADVERTISING OFFICE:
LIVERPOOL 13, ENGLAND.

Telegrams: "Meccano, Liverpool."

Readers' Sales and Wants. Private advertisements (i.e., not trade) are charged 1d. per word, minimum 1/- Cash with order. Readers' advertisements are published as soon as possible; inclusion in the first issue after receiving them cannot be guaranteed.

Small Advertisements. 1/8 per line (average seven words to the line), or 20/- per inch (average 12 lines to the inch). Cash with order.

Display. Quotations for space bookings, and latest net sale figures, will be sent on request.

Collection of over 500 British Empire Stamps (not in album), 32/-; far below catalogue price.—40, Bispham Drive, Meols, Cheshire.

Aeronautical Books; 15 Birds' Eggs; send 2½d. for details.—Jones, 55, Bowham Avenue, Bridgend, Glam.

"Aeromodellers," January 1942—June 1943 and November to December 1943. What offers?—T. Williams, 22, Penketh Road, Wallasey, Cheshire.

Best price securities "M.M.'s" Oct. 1934 to Dec. 1944; complete; as new; what offers?—Markham, 33, Mill Lane, Blackburn, Lancs.

"M.M.'s" Jan. 1940—July 1944; reasonable condition; four missing; 15/-.—Taylor, 11, Maitland Avenue, Cleveleys, Blackpool.

WANTS

L.M.S. Hornby Dublo Clockwork Engine; Dublo City Station Outfit; L.M.S. Dublo Passenger Coaches; Hornby Catalogue 1938; and Hornby Book of Trains. Apply.—Rear, FachGoch, Waenawr, Caernarvon.

Two No. 2 Brake/Third Coaches, S.R.; will also exchange a No. 3C L.N.E.R. for a No. 2 Special S.R. Locomotive; good condition; Clockwork.—Butler, 172, Corhampton Road, Iford, Bournemouth E.

Hornby Gauge "0" or Dublo-Electric or Clockwork Train Set, complete with Accessories; state condition and price.—Wall, The Vicarage, Little Leigh, Northwich, Cheshire.

Two Right-hand Electric Points; One "Royal Scot" Electric Loco.; Two L.N.E.R. Coaches and Rolling Stock; also Dinky Toys' Buses. Replies only from S.A. readers.—Loite, Buccleuch House, Ascot Road, Kenilworth, Cape Town, South Africa.

Hornby Dublo Tank Locomotive (Electric); also mixed Rolling Stock; good condition essential. Particulars and price to—L. B. Cant, 288, Brook Street, Broughty Ferry, Angus.

Trix Engine, Controller, Lines and Points. State price.—Ogilvy, 286, Strathmartine Road, Dundee.

Electric Dublo Streamlined Locomotive; Tender; Articulated Coach Unit; Twelve Straight Rails. Offer £3.—Rawlinson, Knowl School House, Mirfield.

"Modern Wonders," Numbers 1 to 70 inclusive (1937-1938); pay 12/- lot if good condition, unutilized. Also Books by W. E. Johns, good condition: "Sky High," "Steeley Flies Again," "Murder by Air." Write—C. D. Sanson, Kennelmoor, Milford, Surrey. Cyclometer (26 in. wheel), good condition. State make and price.—Tucker, 40, Havelock Street, Aylesbury.

Dublo Rolling Stock; Coaches must be L.N.E.R.; Electric Track; Electric Loco. Shed; Personnel; Stations; Transformer and/or Controller.—Meguyer, 151, Tuffley Avenue, Gloucester.

Hornby (Clockwork) Gauge "0" Rails in good condition; also Hornby Rail Clips—"J. Hitchcock, "Ramnor," Queen's Road, Swanage, Dorset.

V 2 ROCKET BOMB

Modelcraft Plan of German "V 2" Rocket Bomb, Tractor and Conveyor (Scale 1/72)

Price 1'6

Other new releases (1/72):

Barracuda ... 6d. Me 262 ... 6d.
Firefly ... 6d. Me 163 ... 6d.
Austercraft ... 6d. Piper Grasshopper 6d.

If you have not had the Modelcraft Illustrated Price List (Dec.), apply to any Official Stockist, or send 3d. and unstamped addressed envelope to:

MODEL CRAFT LTD.

77 (M.M.), Grosvenor Rd., London S.W.1



SPRING IS HERE

and with it some harmless wishful thinking. Schoolboys wish they could buy enough sports gear to satisfy their boundless energies and Hamleys wish they could supply it. Maybe by next Spring these mutual wishes will be fulfilled. Meanwhile we can offer

TOY CRICKET BATS

size 3 **10'6** each

plus packing and postage 9d.

Hamleys
ESTD 1760
HAMLEY BROTHERS LTD

200-202, REGENT ST., LONDON W.1
(Our only address). Tel.: Regent 3161

Send 2d. in stamps for full list of aeroplane and warship kits and plans.

Here is an offer to Amateur Photographers

Send us your name and address and we will post to you a book entitled "Home Photography." This tells you in very clear, easy-to-follow language how to develop your own negatives, how to make prints on gaslight or bromide paper, and how to make enlargements. Well-known experts have written full directions on these subjects. We will also send a folder giving the Time and Temperature tables for dish or tank development with AZOL and a lot of very useful hints, as well as a fully illustrated list of Chemicals, sundries and accessories which will be helpful to you in your hobby.

*Send 3d. in stamps and these three publications
will be posted to you at once.*

JOHNSON & SONS Manufacturing Chemists LTD., HENDON, N.W.4
Mark your application E/M Department.

THE MECCANO MAGAZINE



- ★ MECCANO
- ★ DINKY TOYS
- ★ DUBLO TRAINS
- ★ HORNBY TRAINS

We are sorry that we cannot supply these famous toys to-day, but they will be ready for you again after the war. Look out for the good times coming!

Meccano Limited
Binns Road
Liverpool 13

