

VOL. XXX. No.6

JUNE 1945

# MECCANO

## MAGAZINE



THE BLACKSMITH

6<sup>d</sup>

**CHEMISTRY** ARE YOU INTERESTED?

Whether you dabble in experiments or pursue a course of serious study you will need our **LABORATORY EQUIPMENT.**

Send 1d. stamped envelope for **PRICE LIST.**

**BECK** (Scientific Dept. G), 60, High Street  
STOKE NEWINGTON, LONDON N.16  
Booklet, "Experiments in Chemistry," 7d. P.O.

*During the National Emergency only limited supplies of*

**VITALITY BULBS**

*are now likely to be available.*

*If your Dealers cannot supply you with the type you require, do let us have full particulars, together with their name and address, because it might just happen that we know of factors who may be able to supply them.*

**VITALITY BULBS LTD**

**NEVILLE HOUSE,  
NEVILLE PLACE,**

**WOOD GREEN,  
LONDON, N.22**

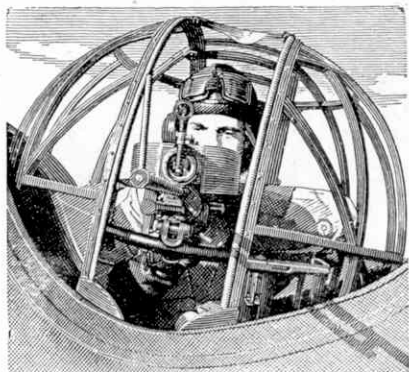

Recording the movements of men and materials. Searching out strategic points and spotting enemy concentrations. These are just a few of the jobs done on Ilford Film by R.A.F. Photographic Reconnaissance Units.

When all this work is finished, Ilford photographic materials, better than ever before, will come back into general use again.

**ILFORD** makers of **SELO** films  
LIMITED

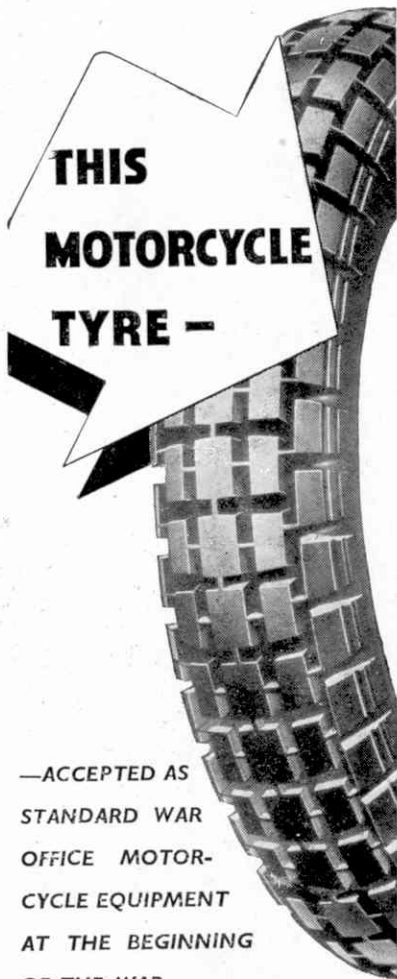

**THIS  
MOTORCYCLE  
TYRE -**

—ACCEPTED AS  
STANDARD WAR  
OFFICE MOTOR-  
CYCLE EQUIPMENT  
AT THE BEGINNING  
OF THE WAR—

**WAS EVOLVED IN 1935  
BY  
DUNLOP**

**MAKERS OF HISTORY  
IN RUBBER**

# FROG

## MODEL AIRCRAFT

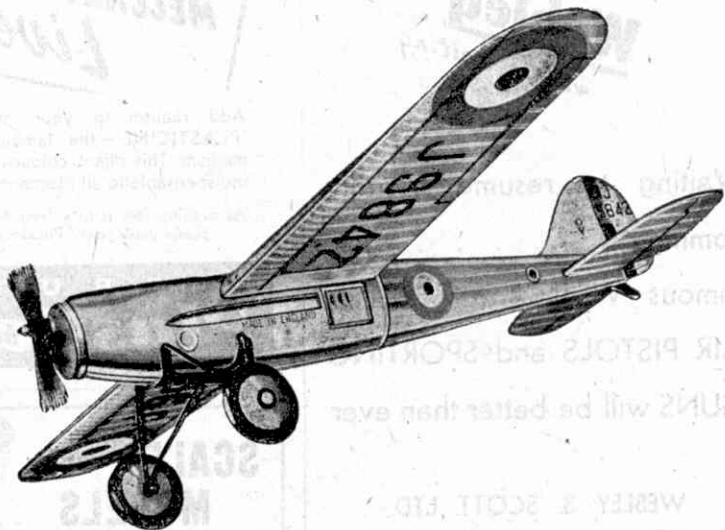

International Model Aircraft have not been producing Model Aeroplanes for 5 years because their experts have been working hard on more important winners, but we hope soon that all the latest models will once again be available to model aircraft enthusiasts. These will include:—

FROG Flying Scale Models, FROG Flying Scale Model Construction Kits, FROG "SENIOR" Flying Construction Kits, FROG "PENGUIN" Non-Flying Scale Model Kits.



Trade Mark  
Regd.

**Sole Concessionaires:**

# LINES BROS. LTD.

TRI-ANG WORKS, MORDEN ROAD, LONDON S.W.19



Waiting to resume friendly commerce . . . . . their famous WEBLEY AIR RIFLES, AIR PISTOLS and SPORTING GUNS will be better than ever

WEBLEY & SCOTT LTD.  
BIRMINGHAM, ENGLAND  
(Est. 150 years)

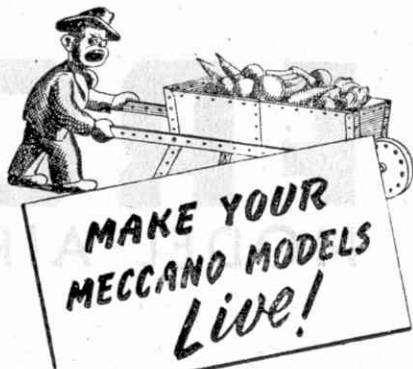

Add realism to your models with 'PLASTICINE'—the famous modelling medium. This pliant, colourful material is indispensable to all Meccano enthusiasts.

As supplies are strictly "rationed" nowadays please make your "Plasticine" last.

**HAR BUTT'S**  
**Plasticine**

## SCALE MODELS



To-day, we would not be engaged in producing so many intricate models for H.M. Government had we not specialised for years in the art of model making. In anticipation of post-war days, we are now planning to put into production detail perfect scale models of Railways, Ships and Engines that will give the utmost satisfaction to all our customers.

Wartime Stock List (L/17), price 4d. post free.

"Building a 2½ in. gauge Flying Scotsman," price 1/-; "How to Build a Traction Engine," price 6d.; "Laying Model Permanent Way," price 3d.

All above are post paid.



**BASSETT-LOWKE LTD.**  
NORTHAMPTON

LONDON: 112, High Holborn, W.C.1  
MANCHESTER: 28, Corporation Street, 4

# TRI-ANG

## TOYS FOR BOYS AND GIRLS

The bad and overpriced toys you have been forced to buy were not ours. We have been making guns, shells and aeroplanes, etc., during the war. Soon we hope to be permitted to re-start making TRI-ANG TOYS.

The illustrations underneath are just a reminder of what real toys look like.



**MINIC**  
Scale Model Clockwork Toys



**LINES BROS. LTD.**  
World Famous  
TRI-ANG TOYS

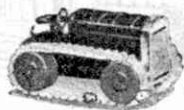

**MINIC**  
Scale Model Clockwork Toys



**TRI-ANG CHILDREN'S CARS**



**TRI-ANG DOLLS' PRAMS**



**UNIQUE AND UNITY**  
CYCLE CO. LTD.  
**FAIRYCYCLES**  
TRICYCLES  
JUVENILE CYCLES



**TRI-ANG "FAIRYCYCLES" (Regd.)**



**TRI-ANG TRICYCLES (Regd.)**

Made at our famous Birmingham Works

## **LINES BROS. LTD.**

AND SUBSIDIARY COMPANIES

UNIQUE AND UNITY CYCLE CO. LTD.

PEDIGREE SOFT TOYS LTD.

**TRI-ANG WORKS, MORDEN ROAD, LONDON S.W.19**

---

**ROUND THE WORLD WITH BSA No. 11**

---



# CEYLON

Dalada Maligawa, the Temple of the Tooth, stands in Kandy, mountain stronghold of the last Sinhalese Kings—a sanctuary for all the Buddhist pilgrims of the world. For, in this Temple, behind many padlocked doors, is a casket which contains the Holy Tooth of Buddha! Legend says that, in 1560, the Portuguese stormed the Temple, and burnt the Holy Tooth, yet millions of faithful Buddhists believe that the Portuguese merely burnt a replica—and not the Holy Tooth itself, which, they say, is indestructible!

Yes, Ceylon is a strange country, with many strange things to see—but you would find familiar sights as well, for instance, B.S.A. bicycles, which are just as popular in Ceylon as they are here at home. You have wanted one for a long time? Ask your parents to see your local dealer. B.S.A. Bicycles are scarce, but he'll do his best for you.



**THE BICYCLE YOU CAN'T BEAT!**

B.S.A. Cycles Ltd., Birmingham, 11.

---

Next Month: "AIRCRAFT VERSUS SEACRAFT." By C. G. Grey

# MECCANO

Editorial Office:  
Binns Road  
Liverpool 13  
England

## MAGAZINE

Vol. XXX  
No. 6  
June 1945

### With the Editor

#### Exit Germany. Now for Japan

The Nazi nightmare is ended. Hitler's Reich, which was to last a thousand years, has crashed to destruction beneath the mighty blows of the Allied Nations. And this time it is unconditional surrender—on land, on sea, and in the air. Never can the Germans say, as they said after 1918, that though the war was lost their army was not defeated in the field. The greatest military machine ever designed for national aggression is utterly crushed. Now we can concentrate all our energies on beating Japan, an enemy as ruthless, cruel and greedily as Germany.

Although we shall still be at war for some time, the defeat of Germany will make a great difference to our lives. The years of darkness are over, and we can look forward with confidence to a gradual return to normal conditions. Some things, indeed, will never again be quite the same; in some ways life will be harder than before. But Europe's wounds will gradually heal, and the misery brought about by the foulest gang of criminals in history will pass away.

#### Pelorus Jack the Second

Many older readers will remember an article in the "M.M." for September 1926 on "Pelorus Jack," the famous white dolphin of Cook Strait, New Zealand. For a period of well over thirty years this remarkable creature met almost every steamer on the Nelson-Wellington run and escorted each one for a distance of some five miles, leaping and gambolling under the bows. At intervals he would disappear for a few weeks or longer, but always he returned to his old haunts and again took up his escorting duties. He became so famous that the New Zealand Government gave him official protection for five

years by a special Order in Council and afterwards for another five years by amendment of the Fisheries Regulations. In April 1912 "Pelorus Jack" disappeared finally, and it is presumed that he met his death in some way.

A New Zealand reader, Mr. H. M. Russell, of Pukeroro, via Hamilton, sends me a newspaper cutting about another white dolphin that has achieved fame in the same waters, by escorting launches in a similar manner. He has become known as "Pelorus Jack II," and the New Zealand Government have amended the Fisheries Regulations to protect him as they did his predecessor.

#### This Month's Articles

	Page
Salvage of the M.V. "Georgic" ..	182
by O. S. Nock, B.Sc., M.I.Mech.E.	
New British Air Liners .. ..	185
by John W. R. Taylor	
World's Largest Aquarium Tanks	186
by Michael Lorant	
The Village Smithy .. ..	190
Ship Cove .. ..	194
by E. Hawthorne	
Fairchild "Packet" .. ..	197
by John W. R. Taylor	
How Files are Made .. ..	198
by Eric N. Simons	

Air News, 192 Books to Read, 191. Club and Branch News, 206. Competitions Page, 215. From Our Readers, 201. H.R.C. Pages, 207-9. Meccano Competitions, 205, Among the Model-builders, 202. New Models, 204. Of General Interest, 196. Photography, 200. Railway News, 188. Stamp Pages, 211, 213.

# Salvage of the M.V. "Georgic"

## A Marvellous Wartime Feat

By O. S. Nock, B.Sc., D.I.C., M.I.Mech.E.

THE curtain of secrecy which has been lowered over most wartime activities of the Merchant Navy has been raised a little recently to give some glimpses of what was happening during the earlier years of the war. Such glimpses have all too often been of disaster—of the sinking of great and beautiful ships, of the epic struggles of tankers, food ships, and freighters to get supplies through to hard-pressed garrisons overseas. It is therefore all the more thrilling to learn of the salvaging of one great ship which the enemy almost certainly chalked up as a total loss. This was the Cunard White Star liner "Georgic." The technical details of a truly astounding feat of salvage were published recently in "The Engineer," and it is from these facts that the following account has been compiled. Readers of the "M.M." may remember that in the November and December issues of 1936 I described the last stages of a trip in her from New York to the London docks. When writing of that serene, lovely voyage I little thought I should write again of the "Georgic" in circumstances so desperate, so fantastic as befell her in July 1941, and which continued until April of the following year.

By midsummer of 1941 the military situation on the frontier of Egypt and Libya was tense. The Axis forces, chased to Benghazi and beyond by Wavell's men in the previous winter, had staged a remarkable come-back, and under the leadership of the fiery Rommel were an altogether tougher proposition. Reinforcements, coming from England by the long route round the Cape of Good Hope, were arriving at Suez, and among the ships bringing the troops was the "Georgic." She arrived safely, discharged the men, and had been re-loaded for the homeward voyage. On 16th July 1941 she was lying at anchor off Suez when she was attacked by German dive-bombers; only two bombs actually struck her, but the consequences were ghastly. One holed the port side, the other exploded in the lift shaft leading to the swimming pool, and it was this second bomb that turned the once-beautiful ship into a raging inferno. The

"Georgic" was unlucky enough to be carrying as part of her homeward cargo a considerable amount of time-expired naval ammunition, and the terrible fire started by the bomb in the lift-shaft exploded these shells. This sent the fire sweeping faster than ever through the ship.

The situation was desperate, but amid these appalling conditions Captain Greig and his men performed a feat of sublime courage and skill that proved the first step towards the saving of the ship. Had the "Georgic" sunk at her anchorage she would almost certainly have become a total loss; worse than that, the wreck might well have blocked the channel to Suez. Captain Greig decided at once to try and beach the ship on a sandbank nearby. By great good fortune the fire had not yet reached the engine-room, and the telegraph to the bridge was still working. Mr. Horsburgh, the Chief Engineer whom I had the honour of meeting on my 1936

trip, and his staff, were at their posts, and Captain Greig was able to get the ship under way. But by this time the bridge was well-nigh enveloped in flames. The fire set off the ship's own magazine, and these further violent explosions added to the damage; but with wet towels wrapped round his head Captain Greig continued to navigate the ship till she was heading straight for the sandbank. By then fire had destroyed the telegraph and telephones, and the gallant commander was driven from the bridge by the flames. But though she safely beached herself she was completely burnt out, and two-thirds full of water.

At first she was thought to be a total loss, but at that period in the war ships were such a vital necessity that a decision could not be made without very serious consideration. The trouble was that she lay stricken in a part of the world where no docks of sufficient size to take her existed, and that even if she could be refloated it would mean a long tow before she could be brought to a place where permanent repairs and refitting could be effected. Salvage experts made the long and difficult wartime journey from England, travelling by sea from Glasgow to Takoradi, on the Gold Coast, and flying across Africa thence to Cairo. It was not until 13th September—nearly two months after the bombing attack—that they reached Egypt and were able to inspect the "Georgic." Although the confusion of wreckage on board, what with debris, oil and water, was in-

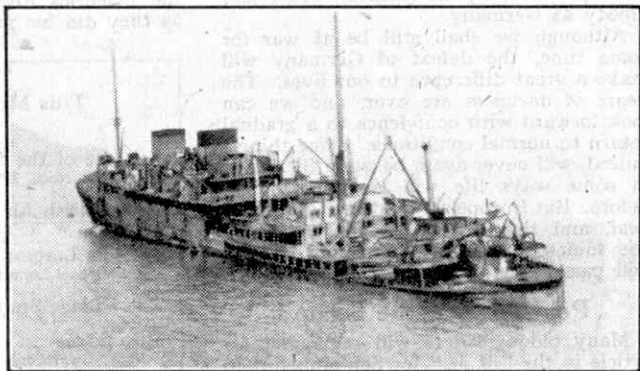

The M.V. "Georgic" beached before salvage operations began.

describable, they came to the conclusion that the ship could be salvaged. A plan was formed for refloating her, and carrying out temporary repairs at Suez; then for her to be towed as a derelict to Bombay for final and permanent repairs in dry dock there.

But it was one thing, even for highly experienced engineers and seamen, to conceive such a plan; the general difficulties of wartime, quite apart from the probability of further enemy attack, made its execution one of almost insuperable difficulty. The first job was to begin pumping out the water. The salvage vessel "Confederate" was laid alongside the wreck, and she supplied power to operate the salvage pumps which had been purchased and installed in the "Georgic." Divers began work below, wedging



and plugging leaks, while other Egyptian workmen made a start with clearing debris and shoring up bulkheads. While this work was in progress and very slow progress it was too, Captain Manley, Marine Superintendent of the Cunard White Star Line was getting materials and gear ready for the next stage of the operations. Several of the company's liners put into Suez during this period, and Captain Manley relieved them of many items of equipment which were to prove useful later on. Foremost among these was the "Maurelania's" 8-inch towing wire, on which the "Georgic" was eventually towed all the way to Karachi.

But while the "Georgic" was slowly coming up, it was all the time realised that the temporary repairs to her hull were merely a means to get her afloat; much more was required before the tow could be commenced. Captain Manley's plan was to build a huge cement box covering the whole area of the damage caused by the bomb which holed the port side; but again the peculiar difficulties of wartime made it doubtful whether this scheme could be carried out. There was not a great deal of cement in the Middle East at the time, and all of this had been allocated to the military authorities. Needless to say Captain Manley had great difficulty in persuading them that his needs were greater than theirs, for with Rommel on the frontier they might at any time have had to build additional fortifications. Nevertheless, he was successful in wheeling a certain amount of cement out of them; what is more he had it ready to start work on the "box" the moment the "Georgic" was afloat. By 27th October, that is six weeks after salvage began, she was sufficiently upright for an attempt to be made at towing her off the sandbank to an anchorage. As the tide approached the full the salvage vessel "Confederate" began towing. It was an anxious moment, but in a quarter of an hour the "Georgic" was moving; another 45 minutes and she was safely at anchor in Suez roads.

The period between 30th October when work began on the cement box, and 29th December, when the long tow began, was one of continuous and extraordinary difficulty. First of all the "Confederate" was ordered away to more urgent work. In consequence the "Georgic" was left without power to drive the pumps, and light to see by. But the work went on, in the light of hurricane lamps, with the men often almost up to their waists in water. Another salvage vessel arrived, a Greek ship, but when Captain Manley discovered she was loaded with live shells he found an early excuse to dispense with her aid! The Cunard White Star men searched Cairo and Alexandria as with a fine comb for means of providing power and light in the ship, and eventually their various efforts produced an electric generator from one source, and a 12 h.p. petrol engine out of an old American tractor from another. This truly comical makeshift was completed when these two units were bolted down together on the fire-buckled floor of what had been the main dining saloon of the ship. Makeshift or not, it worked alright, and with the aid of this electric power and light the cement box was soon finished.

In the meantime arrangements were being made for ships to tow the "Georgic" to Bombay. This again was no easy matter at a time when there were such demands for ships of any kind. Eventually the Ministry of War Transport instructed the ss. "Clan Campbell" and the ss. "City of Sydney" to carry out the job. The "Georgic" was to be towed as a derelict, that is with nobody on board, and with a ship of

her great size it was essential for one ship to steer her while the other towed. The "Clan Campbell" arrived at Suez first, and being a powerful ship was chosen for towing; and in readiness for taking the "Georgic" down the dredged channel to the outer roads she was made fast alongside. The ships of the Clan Line are specially equipped for the conveyance of heavy loads, and in ordinary times they carry locomotives, buses and other similar cargoes. With tugs fore and aft the two big ships moved down the channel on the evening of 28th December. But even at the moment they were ready to leave Suez there was a narrow escape from disaster. During the night the "Clan Campbell" anchored, with the "Georgic" riding near by, and now connected to her only by the towing wire. The wind freshened, becoming stronger than the tide, and the "Georgic" began to move towards the "Clan Campbell"; the latter

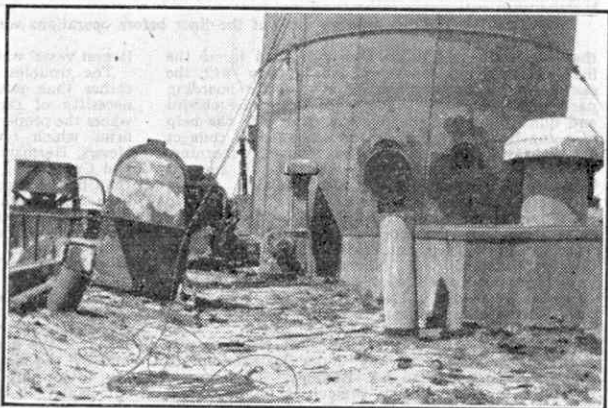

A view of the damage on deck.

ship had to weigh anchor and manoeuvre to avoid a collision, and the situation became extremely dangerous. Other ships were lying near; there were rocks and shoals on either side of the roads, and then at the critical moment when the "Clan Campbell" was trying to turn the "Georgic" head to wind so as to steady her, the cable parted and the great derelict was loose!

Tugs came to the rescue, but it was not until 12 noon on the 29th that the "Georgic" was once again made fast to the "Clan Campbell." By then the "City of Sydney" had arrived, and on that same evening the tow began. They started away down the Red Sea, and gradually they worked up to a speed of 5½ to 6 knots. But after four days a very strong north wind sprang up, and despite the efforts of the towing and steering ships the "Georgic" became increasingly difficult to control. They tried to turn her head to wind, but in so doing both steering wires parted, so that the steady effect of the "City of Sydney" was lost; and with such a sea running there was no hope of passing fresh wires. For 36 hours the situation was on a razor edge. The "Georgic" was rolling heavily in every trough of the sea into which she fell; the wind was blowing gale force, and she sheered first one way and then the other. Only the superb seamanship of Captain Vooght of the "Clan Campbell" saved her from breaking away altogether.

After nearly two days of this the anxiety of all concerned was increased when it was seen that the "Georgic" was listing to port. It was evident that the cement "box" had begun to work away from the ship's side, and water was leaking in. But it was impossible to do anything until the wind and the sea moderated. For two more days, days of terrible anxiety,

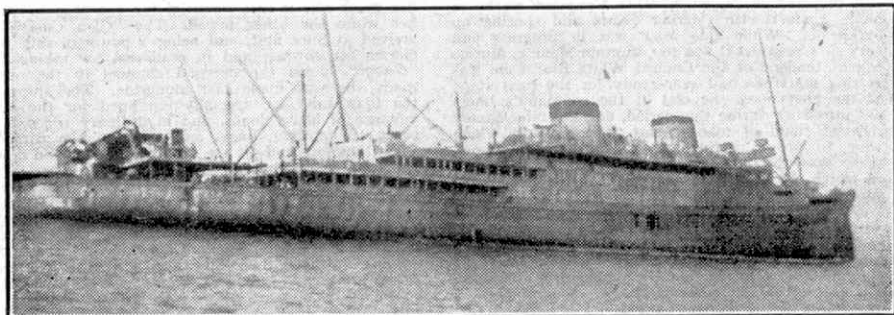

Another view of the liner before operations were started.

the watchers on the "*Clan Campbell*" had to see the list increasing, but at last, on 7th January 1942, the sea had gone down enough for a volunteer boarding party to set out. They succeeded in getting aboard and quickly got the pump going, and with the help of a tug from Port Sudan they managed to connect the "*City of Sydney*" on the following morning. Towing restarted, and Port Sudan was reached without further incident on 10th January. Before they could proceed further the cement "box" had to be repaired, but while labour and materials were being secured and the work started, both the accompanying ships were ordered away. The "*Clan Campbell*," which had rendered such inestimable service, received a still more dangerous assignment—a convoy for Malta; in this she was heavily damaged by bombs, and her gallant captain was killed. Such was life in the Merchant Navy.

It was not until March 1942 that the tow was restarted, and then it was under instructions to make for Karachi, and not Bombay. This was to introduce further immense difficulties later on, but the immediate job was to get her there at all. By that time the ss. "*Recorder*" of the Harrison line had been allocated by the Ministry of War Transport. The "*Recorder*" was a cable ship, with the bows specially equipped for paying out cable to be laid on the floor of the sea. They left Port Sudan on 5th March, with the tug "*St. Sampson*" as steering ship, but they were scarcely a day out when the wind shifted to the north once again and began to blow hard. Again the difficult manoeuvre of turning the "*Georgic*" was attempted, and this time she was successfully brought head to wind. Then in the early hours of 7th March the little tug shipped a heavy sea; her engine room was flooded and she had necessarily to slip the wire by which she was hanging on to the "*Georgic*." The "*Recorder*" could do nothing to help, but fortunately the distress signals of the "*St. Sampson*" were picked up by the ss. "*Dorsathire*," a hospital ship, and the crew of the disabled and sinking tug were saved.

On the following day the ss. "*Haresfield*," of the British India line, arrived with instructions from the Ministry of War Transport to help in the tow. The weather was now much improved, and there was no great difficulty in making fast the "*Haresfield*" as steering ship. This time the cement "box" inside the "*Georgic*" had withstood the strain of the storm, and the great ship was riding quite upright. So they started off again, with a second tug, the "*Pauline Moller*," ahead of the "*Recorder*" to augment the towing power. Thus this strange procession of four ships—"*Pauline Moller*," "*Recorder*," "*Georgic*" and "*Haresfield*" came to Aden, where the "*Pauline Moller*" had to slip the tow owing to shortage of coal. After that they steamed on, slowly but uneventfully, and at last they arrived off Karachi in the early hours of 21st March 1942. With the plentiful assistance of five tugs and two dredgers the "*Georgic*" was safely moored alongside; she was the

largest vessel which had ever entered Karachi harbour.

The troubles from now onward were engineering rather than navigational ones, and arose from the necessity of carrying out major repairs in a port where the proper facilities were not available. The two firms which bore the brunt of the heavy work, Messrs. Hermann and Mohatta, and Messrs. Carstairs and Cummings, were more at home building bridges than in repairing ships; yet they set about the work with a determination, an enthusiasm and a speed that was really inspiring. The final repair to the hull could only be done in dry dock, but so that the dock at Bombay should be occupied for the very minimum of time, everything possible was done at Karachi, including the terrific job of straightening and strengthening the stem bar of the ship, which had been badly damaged in a collision with another ship while the "*Georgic*" was being run aground in Suez roads. Much of the damage here was below the water line, but by the temporary flooding of certain holds in the after part of the ship she was trimmed up sufficiently to bring the whole area of the damage above water. With the facilities available it was not possible to remove the twisted stem bar, and an attempt was made to repair it in position. A steel cage was built to fit round it, and a fire was made in this cage. When the bar was really hot it was beaten, levered and dragged into place—all this with a massive steel forging.

Meanwhile equally vital work was being done in the engine rooms. Again there was no gear big enough to lift out the huge electric generators, and so all cleaning and repairs had to be carried out where they stood. These generators had first to be washed thoroughly with fresh water, to eliminate all the salt, and after being cleaned and dried out by hand, they had to be baked in order to restore the insulation. As the generators could not be removed improvised ovens were built around them. Then, after all this work had been most carefully carried out, there came the crucial test—would the generators start up? When the first one had been completed a trial was made. It was a failure; the generator refused to start. For two whole weeks the engineers tried and tried again. Then at last it started; a tremor ran through the ship. There was no more thrilling moment in the whole process of salvage than this, when Captain Manley and his stalwarts realised that the "*Georgic*" was alive once more. The remaining three generators were brought into action one by one, and at last, on 11th December 1942, the "*Georgic*" left Karachi under her own power. She was in dry dock at Bombay for a bare three weeks, and then, with 5,000 tons of pig iron for cargo, she left for England. The voyage was uneventful, and after making the splendid average speed of 16 knots she came into Liverpool early in March 1943—a placid end to a well-nigh incredible adventure.

For the photographs used to illustrate this article we are indebted to the courtesy of the Cunard White Star line.

# New British Air Liners

## De Havilland and Miles Post-War Types

By John W. R. Taylor

AT last some details may be given of a few of the fine aircraft now being built in British factories for use on our post-war air lines. We in this country are notoriously modest in our praise of home products, but there is little doubt that a passenger who flies on

compartment is also dispensed with.

The Miles M-56 is also a twin-engined monoplane with a tricycle undercarriage, but is much larger than the "Dove" as it has two Rolls-Royce "Merlin" engines, specially de-rated for civil use, and accommodation for 24 passengers. It will form an ideal replacement for the ten-year-old Douglas D.C. 3 ("Dakota") which has put in so much good service on the world's airways. It is comparable in size with the D.C.3, with a wing-span of 80 ft. and an all-up weight of 25,600 lbs., but has a much higher performance, without sacrificing really good take-off and landing characteristics. Its cruising speed of just under 200 m.p.h. is based on only 33 per cent. of the 3,240 h.p. available for take-off, and the M-56 should, therefore, be quite economical. If required, it can be fitted with two Bristol "Perseus" or four Armstrong-Siddeley engines instead of the two "Merlins." Special attention has been paid to the comfort of the passengers and the cabin has a volume of 1,330 cu. ft., with a floor area of 200 sq. ft. and a height of 78 in. There is also 100 cu. ft. of luggage and mail space. The cabin can be pressurised up to 2½ lb./sq. in. for increased comfort above 10,000 ft.

The M-60 is somewhat similar in general outline to the M-56 but is smaller, having accommodation for only 14 passengers. It is fitted with four in-line engines of a new type developed from the de Havilland "Gipsy" VI. An interesting point is that the seven types of aircraft recommended by the Brabazon Committee and subsequently ordered by M.A.P. did not include a 24-seater, whereas Railway Air Services plan to operate with two basic types—a 14-seater and a 25-seater. So it seems as if the M-56 and M-60 would fill the bill very nicely.

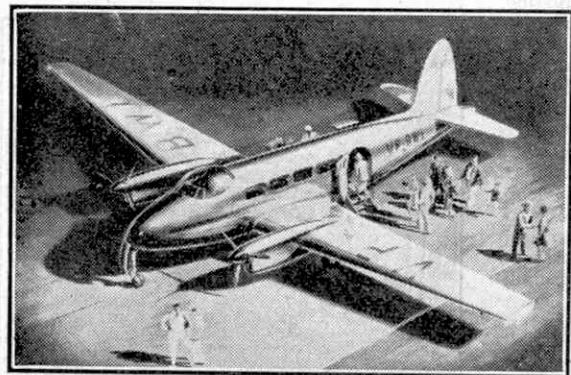

An artist's impression of the de Havilland "Dove" 8-11 passenger transport at an airport. This new civil aircraft is now under construction.

British airways after the war will fly in aircraft second to none in the world for comfort, performance and reliability.

The Vickers V.C.I. and Handley Page "Hermes" have already been mentioned in our pages. Now the de Havilland "Dove" and Miles M-56 and M-60 may also be described. None of these aircraft is flying yet, but work on the prototypes is well under way and the "Dove," at least, will soon be available in fair numbers now that the war in Europe is won. All three come in the category of feeder-line transports, which means that they are comparatively small, high-performance machines designed to carry passengers from internal aerodromes to the main international air termini—the kind of job that was usually done by the de Havilland 86 and 89 biplanes before the war.

The "Dove" (D.H. 104) bears a distinct family likeness to the "Mosquito," but is of all-metal construction and has a tricycle undercarriage. It is powered by two of the latest de Havilland supercharged "Gipsy Queen" engines, each of which drives a new three-bladed constant-speed, feathering and braking propeller, also developed and built by de Havillands. This works in reverse pitch in landing, so throwing the slipstream forward and greatly reducing landing run.

Weight and performance data are not yet released but the "Dove" will carry eight passengers, with toilet accommodation, fore and aft freight compartments, and a crew of two with dual control and convenient radio layout. Without toilet the cabin will seat 10 passengers, or 11 if the aft luggage

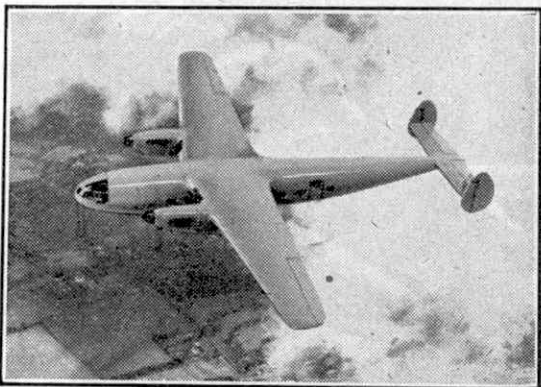

A model of the Miles M-56, another new aircraft for post-war air lines. It will have seating for 24 passengers.

# The World's Largest Aquarium Tanks

## An Underwater Film Studio

By Michael Lorant

REGULAR readers will remember an article in the "M.M." for February 1941, describing the world's largest aquarium tanks, constructed on a beach 18 miles south of St. Augustine, Florida, U.S.A., not far from the famous Daytona Beach. This month we give some further pictures of this remarkable underwater film studio.

There are two tanks, connected by a flume or shallow trough. One is rectangular, 100 ft. long, 40 ft. wide and 18 ft. deep; the other is circular, 75 ft. in diameter and 11 ft. deep. Both tanks and flume are made of steel, electrically welded, and surfaced inside with gunite, a mixture of sand and cement applied by a specially designed "gun."

Enclosed galleries run at different levels around the perimeter of both tanks, and each of the galleries faces inward upon a circle of portholes in the sides of the inner tanks. Each visitor can sit comfortably in a chair and look into the lighted tank through its individual porthole in much the same way that he looks on the lighted screen at his favourite picture theatre. The portholes are placed in such a way as to make it possible for the

visitor to look into the tanks from four different levels—from the sides at a level just above the bottom of the tank; from the sides at a level just below the top of

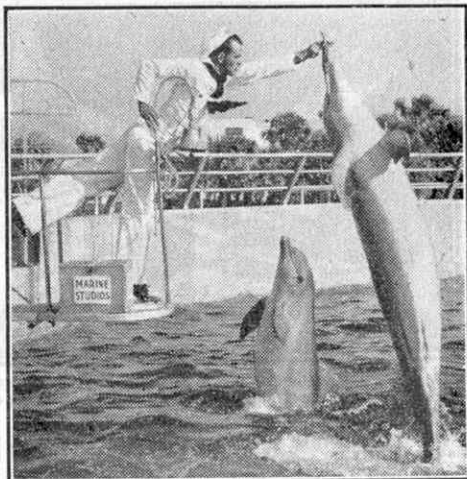

Baby porpoise looks on while its mother leaps high in the air to take food from the hand of the attendant. The dinner bell is used to call these creatures at meal time.

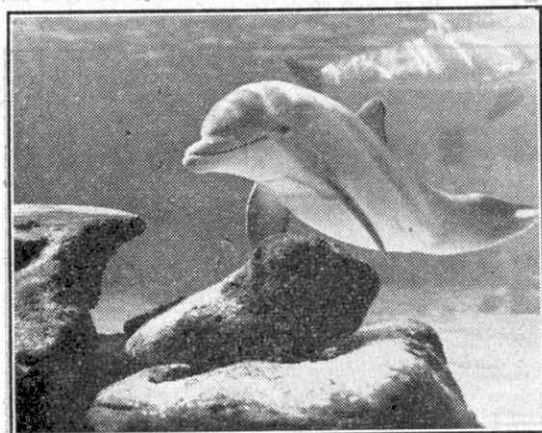

"Pudgy," the porpoise grins at visitors through the portholes.

the tank; from the bottom of the tank looking upward, and from an open gallery around the top of the tank.

Every effort has been made to duplicate conditions actually existing in the ocean. For example, a coral garden is built in the tanks. The highly-coloured reef fishes seek safety from their natural enemies just as they normally do in the open sea, by escaping in among the interstices of the coral growth where the larger fishes cannot follow them. Various sea grasses and seaweeds grow from the bottom of the tanks, thereby increasing the beauty of the scene and affording protection for certain small forms such as the pipe fish. Jelly fish float near the surface

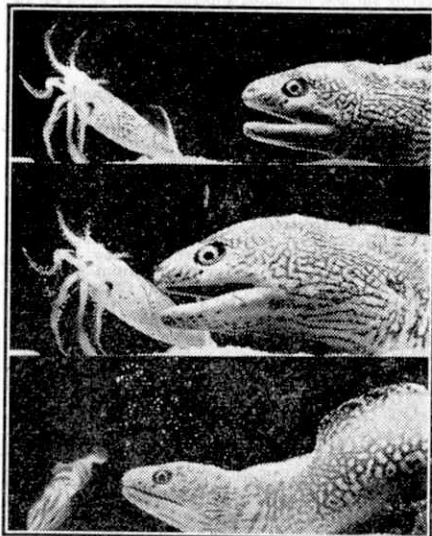

These pictures show a brown snake eel attacking a squid. Top: The eel approaches the squid who is apparently unaware of its danger. Centre: The eel opens his mouth to strike. Below: The squid, sensing danger, makes use of a novel means of defence provided by nature, and expels water through small syphon-like arrangements in the back of his body and darts away to safety.

accompanied by their camp followers, the tiny fish that derive safety from their stinging tentacles. Lobsters, an octopus,



Porpoises enjoy having their heads scratched. Staff divers of Marine Studios feed them three times daily.

an 11 ft. spider crab, and other bottom feeders can be seen from the lowest row of portholes. Altogether, there are some 85,000 species of aquatic animals.

The design of the tanks was recommended by technical motion picture experts, who worked out the various camera angles necessary to give producers the greatest latitude in the filming of scenes. These angles were the controlling factors that determined the shape and

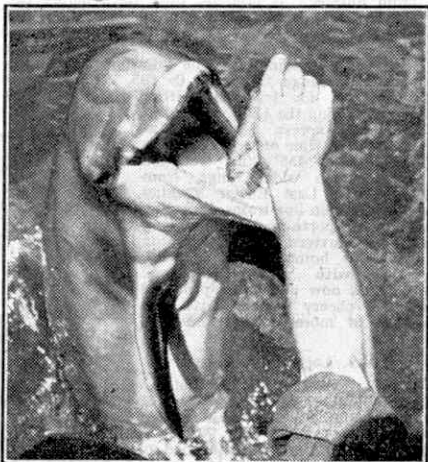

"Pudgy" opens his mouth.

dimensions of the tanks.

Capturing alive and transporting the larger species of sea creatures that are shown in these tanks presented difficult problems that had to be solved before the project was feasible. Extensive research has developed a method of injecting a drug through a hypodermic needle in the harpoon into the largest sharks, porpoises, etc., which puts them to sleep almost instantly.

To handle and transport these fish and aquatic mammals a special 48 ft. boat was designed and built in St. Augustine. It is constructed entirely of wood. Its most notable feature is a well in its hull that opens into the sea through a trap-door. The well is watertight. In its centre is a metal tank placed on rollers so that it can be easily lowered through the trap-door in the stern of the hull into the water where a big fish, under the temporary influence of the anæsthetic, is manoeuvred into the tank and pulled back into the boat, entirely without injury.

# Railway News

## Great Western Tidings

During 1943-4 over 140 new locomotives were built at Swindon. These included 62 L.M.S. "8F" type 2-8-0s numbered 8401-62, which are performing hard work in many parts of the country, including the West of England, while on loan to the G.W.R. Among withdrawals have been several 0-6-0 tanks of various early classes, including Nos. 1784, 1799 and 2705, and No. 3595, another of the famous little Dean passenger tanks of the 2-4-0 type.

Train numbers as used on busy days before the war have reappeared to a limited extent on the front of express locomotives as a daily feature, mainly on morning and evening long-distance trains to and from Paddington. The "down" numbers so far reported range from 100 to 195, all ending in "0" or "5," for trains in either direction. The "Castle" hauling the 4.0 p.m. Bristol-Paddington express, Saturdays excepted, at the time of writing carries the headboard "455"; "up" numbers cover a much wider range, from 250 to 840. Last Easter Monday evening 15 main line trains, including many relief portions travelling long distances, arrived at Paddington within two hours. Such activity, together with greatly improved lighting as now allowable, provided quite a cheery aspect with the promise of more normal times to come.

## L.M.S. Locomotive Notes

L.M.S. No. 20002, the veteran Kirtley double-framed 2-4-0 which we illustrate this month, is still at work at the age of over 70. It is often seen in the neighbourhood of Nottingham. No. 20012, until recently the only other survivor of this class, has now been scrapped. There are still 10 ex-Midland 0-6-0 engines dating from the same mid-Victorian era on the active list that are nearly as old.

Class "4P" 3-cyl. 2-6-4Ts are again much in evidence on the Tilbury and Southend section. Engines of this series are numbered 2500-36. They have tapered boilers. In consequence of the return of more powerful six-coupled locomotives to those important residential services running to and from Finchurch Street, eight 4-4-2 outside cylinder tanks of the former Midland L.T. and S. type have moved from there to the Leicester and Nottingham district.

No. 5543 "Home Guard," of the "Patriot" 4-6-0 type, has run well over 200,000 miles since being christened at Euston in 1940 at a time of national crisis. On several occasions this engine has hauled special train loads of American troops, and at present is employed mainly on express parcels or newspaper trains. No. 5543 is one of the last 10 of the "Patriot" series built new at Crewe in 1933, the numbers running from 5542-51. The first 42 "Patriots," numbered 5500-41, were officially rebuilds of "Claughton" class 4-6-0 engines, being turned out from Crewe and Derby during 1932-3 with new "Scheme 3" boilers and "Royal Scot" type cab, cylinders and motion, the number of cylinders thus being reduced from four to three. The inside cylinder was placed well forward of the outside ones in order to secure a reasonably long connecting rod. In service they have proved fast and capable engines with suitable loads.

Previously, round about 1928, twenty of the original "Claughtons" had the same new boiler fitted,

pressed to 200 lb. per sq. in., and providing a total heating surface, including superheater, of 2,098 sq. ft. This greatly improved their average performance. Of this or the original batch, there is to-day only one survivor. Owing to the standardisation and recent rapid construction and modification of the more powerful "Royal Scot" and Stanier "5XP" classes, the "Claughtons" have had a comparatively short life—30 years or less.

The latest rebuilt "Royal Scots" we have noted are No. 6120, "Royal Inniskilling Fusilier"; No. 6129, "The Scottish Horse"; No. 6160, "Queen Victoria's Rifleman"; No. 6149, "The Middlesex Regiment"; and No. 6166 "The London Rifle Brigade." Many more of the already numerous class "5" two-cyl. 6 ft. 4-6 0 mixed traffic locomotives popularly known as "Black Staniers" have appeared in traffic, largely on the Midland Division, including the West of England line. They are numbered from 4825 up, ex-Derby, and 4860 onward, built at Crewe. On the Midland line into Bath, "8P" 2-8-0s have been working lately; engines of this type are still under construction at various works of the L.M.S., L.N.E.R., and G.W.R.



First portion of the "Cornish Riviera Express" on a pre-war Saturday, headed by a "King" carrying a train number, as explained on this page. Photograph by H. C. Casserley.

Among locomotives of interest recently withdrawn may be mentioned No. 15103, class "1P," rebuilt. This was the last remaining member of Dugald Drummond's small-wheeled 0-4-4 passenger tank class designed for the former Caledonian Railway in 1886. Others include No. 14765 "Clan Stewart," of the newest Highland Railway 4-6-0 "Clan" class illustrated in the June 1944 "M.M.," and dating from 1920; No. 14685 "Dunvegan Castle," class "3P," of the much older Highland "Castle" series; four more of the famous ex-Lancashire and Yorkshire 5 ft. 8 in. 2-4-2Ts, which have rendered such good service for many years under arduous conditions; and another "7P" 0-8-4T, No. 7942. Further withdrawals are of small but hard working Webb tank engines that have been so familiar on the former London and North Western Railway, and Western Division L.M.S., for round about 50 years or more, including 0-6-2 "coal tanks" with small 4 ft. 5½ in. driving wheels, numbered 7768 and 27626. The latter had been again renumbered on the non-standard list, with 20,000 added to the previous L.M.S. numeration. A Webb 2-4-2 passenger tank scrapped was No. 6743 of the "1P" 5 ft. 8½ in. class.

Streamlined "Pacific" No. 6235, although allocated the name "City of Birmingham" some time ago, was not officially "named" by the Lord Mayor of that city until 20th March last, as wartime exigencies had not permitted the holding of the ceremony that had been planned earlier.

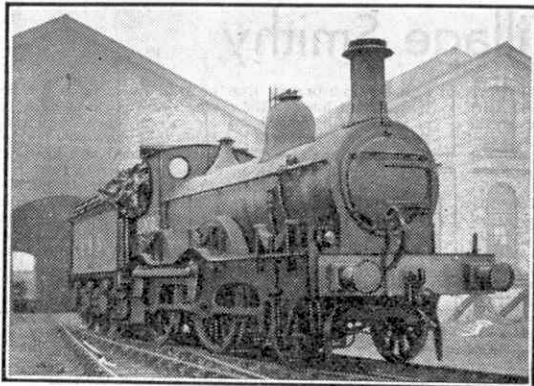

L.M.S. No. 20002, the oldest passenger tender engine in Great Britain. The photographs on this page are by H. C. Casserley.

#### A Fine "Castle" Performance

One or two good G.W.R. runs reported in these pages recently were logged on fine summer days, but the following details, writes Mr. R. A. H. Weight, describe a fine effort in winter in face of pouring rain and a south-easterly gale, on the up morning Bath-Paddington non-stop express when running to its peacetime 108 min. timing for 107 miles with a load of 355 tons. The engine was No. 4079 "Pendennis Castle," of L.N.E.R. 1925 trials fame.

After passing Box, 5 miles, in 7 min. 50 sec. and attaining 56½ m.p.h., the two miles up at 1 in 100 through Box Tunnel brought speed down to 34, followed by a maximum of 72½ down the slight descent past Chippenham and a 51 m.p.h. minimum on Wootton Bassett incline, so the junction station of that name was passed punctually in 27½ min. for 23½ miles. Now, however, came a most depressing crawl from signal to signal right from Hay Lane to Swindon station, causing fully 7 min. loss, but the driver immediately afterwards set out to try and regain some time, in spite of vile weather and a fast booking. On gently descending or level track, along the route of the "Cheltenham Flyer" and "Bristolian," which were much lighter trains, 72 m.p.h. was averaged past Wantage Road, Didcot and Goring, so it looked as if Reading would be passed at full speed only about 6 min. late. But the Engineer had decided otherwise. There was a slowing on account of permanent way repairs past Reading West Yard, and the station was passed at not more than 40-45 m.p.h., nearly 7½ min. late. Amid swirls of steam and smoke, lashing rain and howling wind, the Bristol driver, thankful that the A.T.C. apparatus gave him audible indication of every distant signal, averaged almost 70 between Maidenhead and Hanwell and reached Paddington only 4 min. late, having covered the 107 miles in no more than 103 min. net, allowing for the severe delays that had cost 9 min.

As the crowd of passengers made their way along the dry platform, well protected by Paddington's big roof, it is to be hoped that some at least gave an appreciative thought to the locomotive and her faithful crew, though no one but the recorder stopped to express it. In addition to the extra two or three hundredweight of coal which the fireman has to lift into the fire-box during the winter months on any such run on account of the additional steam needed for heating the train, the adversity of the elements that day had probably necessitated an even greater increase on normal coal consumption in order to maintain the fast speeds secured.

#### Heavy Military Traffic Continues

Although the climax in military traffic on British railways was passed round about "D Day," this continues to be very heavy. During January, a month in which severe weather was prevalent, over 14,000 specials were run for Service personnel and stores, 230 ambulance trains, 20 prisoner of war specials, and nearly 200 Forces' mail or parcel trains.

Some three million wagonloads of ordinary freight traffic are being handled per month.

#### 360,000 Tons of Scrap Material

Thanks to active salvage drives, 360,000 tons of scrap material was disposed of by the British railways last year. This was mostly iron and steel that could be put to further important use, though there were 5,888 tons of paper and cardboard and 1,500 tons of waste food scraps, to say nothing of 580,000 bottles!

#### Effective Power Without Height

With maximum height above rail level no more than 8 ft. in order to clear a low overbridge, a smart and powerful little 0-4-0T locomotive has recently been built by W. G. Bagnall Ltd., Stafford, for the industrial lines of a large iron and steel company. The low height is achieved by a well cab, the sinking of chimney and domeover in the saddle tank, and the reduction of the coupled wheel diameter to 2 ft. 9 in.

Passenger traffic on American railways in 1944 was the greatest ever handled in any one year. Over 95 thousand million passenger miles were run. This figure represents an increase of nearly 9 per cent. over that for 1943.

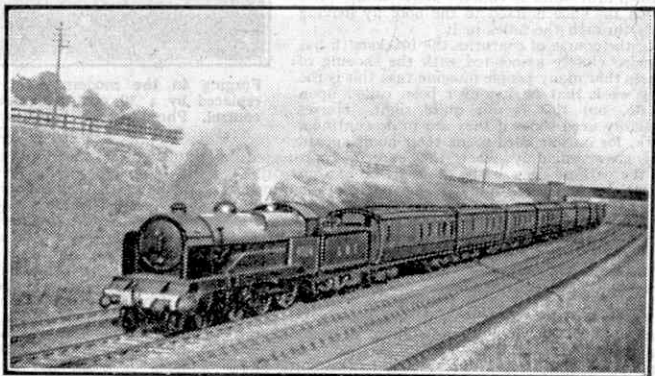

L.M.S. No. 6004, the last "Claughton" in service, apart from those rebuilt as "Patriots."

# The Village Smithy

THE village smithy, where it still exists, is always an attractive place, usually dark and mysterious, with the heavy anvil in the centre, and in one corner the built-up hearth, with an array of hammers, tongs and other tools leaning on it as if waiting for the moment to spring into action. Horse-shoes are everywhere, some in a pile in a corner and others hung on nails driven into the walls and into the beams that invariably cross the ceiling. With them are bars of iron, spring leaves, forks, spades and other agricultural implements, many of them in bits and pieces. There is a curious smell about the place, a compound of rusty iron, burning coke and the parings of horses' hoofs. Apart from the anvil, and the smith himself, the hearth is the most prominent feature. There is not always a bright fire on it, perhaps just the faintest red glow can be seen; but we know that it only requires a touch or two on the giant bellows to create a sort of miniature volcano. As can be seen on our cover, this is white hot at the centre, with short fierce blue flames and a cloud of smoke rising from the top of the cone into which the smith rakes the fuel.

If the visitor is fortunate he comes along at the time when there is a horse to be shod. The nails holding on the worn shoe are quickly dug out by means of pincers, and the hoof is trimmed with a sharp knife and rubbed down with a heavy rasp. Drastic treatment, but the horse does not seem to mind it at all. Then a shoe of the right size is picked out. It may want a little alteration to make it fit accurately, so it is pushed into the heap of burning coke and the fire is blown up vigorously. When it is red hot it is lifted out with a pair of tongs, laid on the anvil and fashioned as required by a few deft blows of the hammer. If it requires rounding in a little, this is done over the pointed end of the anvil. The noise is terrific, for the smith is not satisfied with the blows that are required to shape the shoe; in between them he beats a tattoo on the face of the anvil itself, so that there is a regular ringing chorus.

By this time the shoe has cooled, so back it goes on the hearth to be heated up again. Then comes the greatest moment of all. As soon as it is hot enough it is again seized in a pair of small tongs or pincers, the horse's hoof is lifted, and the shoe is pressed tightly on. There are clouds of acrid smoke and a smell of burning horn as the shoe makes a bed for itself, and then it is thrown into water to cool it. More paring, after which the shoe is fixed to the hoof by driving nails through the holes in it.

In the course of centuries the blacksmith has been so closely associated with the shoeing of horses that many people imagine that this is the only work that he has ever been called upon to do, but this is not quite right. Horses certainly need shoes if they are to do continual work, for on our hard roads their hoofs spread and grow ungainly when they are not protected. In the earliest days wisps of straw or of some other material were used, and in some parts of the world this is done to-day. Iron shoes were known to the Romans, and to other ancient peoples, but as far as Great Britain is concerned it seems unlikely that they were used until the Norman Conquest or about that time. Yet there were smiths long before horses were shod. They were metal workers, and the work of a smith really consists in joining and shaping metals.

The village blacksmith could turn his hand to such work as the fashioning and repair of agricultural implements of all kinds. His skill indeed often went far beyond this, as countless magnificent gates and other examples of beaten ironwork show. In days gone by he was almost a legendary figure, and the awe and hero worship of the small boy who now

brings him a broken iron hoop to be mended can be traced right back to the mysticism of the first workers in metals, who guarded their secrets jealously. There are many references in the Bible that show how highly the earliest metal workers were regarded, and heathen mythologies include gods of the forge such as the lame Vulcan of the Greeks and Romans. A famous legendary smith of our own country was Wayland Smith, who had a secret forge in a wild part of Wiltshire. He was never seen by human eyes, but he would shoe a horse left for the purpose near his smithy if a sixpence was laid on a stone as his fee.

Like many other tools of the ancient craftsmen, the hammers with which the smith forged horse-shoes and ploughshares and other implements have now grown into gigantic power-operated tools, an example of which is illustrated on this page. Such hammers have come into existence because the smith's hammer was incapable of dealing with work on the scale now required. The first step in this growth came when

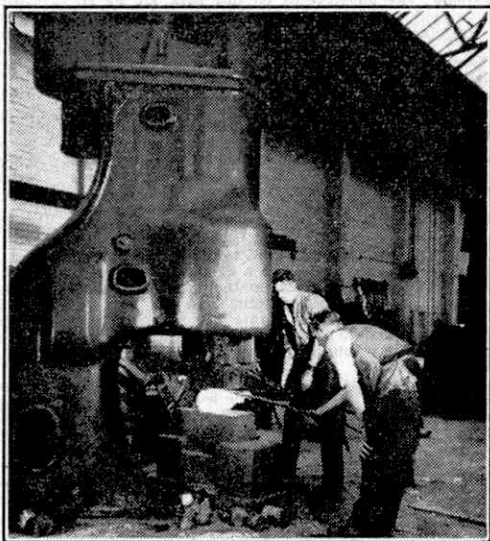

Forging in the modern style, the blacksmith's hammer replaced by a 30 cwt. pneumatic hammer under accurate control. Photograph by courtesy of David Brown and Sons (Huddersfield) Ltd.

water power was brought into use to operate the tilt hammers of the Wealden iron industry, tools that had large hammer heads on long shafts or beams that were raised by means of a wheel furnished with projecting pegs, and allowed to fall on the metal being forged on the anvil. Steam was later used for operating tilt hammers; and then came Nasmyth's great invention of the modern form of steam hammer, in which the steam works directly on a piston that raises and lowers the gigantic tip, or hammer head. This may weigh many tons, and under perfect control can deliver a blow far exceeding that of the heaviest hammer the smith wields by hand. With it gigantic masses of white hot metal are easily and rapidly forged to shape. There could be no greater contrast than that between the smithy of tradition and the forging shop of a gigantic modern steel works.



# BOOKS TO READ

Here we review books of interest and of use to readers of the "M.M." With the exception of those issued by the Scientific and Children's Book Clubs, which are available only to members, and certain others that will be indicated, these should be ordered through a bookseller. We can supply copies to readers who are unable to place orders in this manner. Order from Book Department, Meccano Ltd., Binns Road, Liverpool 13, adding 6d. for postage.

## "COAL AND ALL ABOUT IT"

By D. H. ROWLANDS (Harrap, 7/6 net)

There could not be a more attractive subject for a book than coal, our greatest national asset. Its production has been a basic British industry for centuries, and our great industrial advances in modern times have been due in the last resort to unfailing supplies of this mineral. During the war we have learned how much we depend upon it, and we shall have to look to the best means of mining and using it to ensure prosperity in the future. Knowing this, every reader of the "M.M." will be anxious to learn as much as he can about coal. Here is the answer in a book that is attractive and easy to read, but at the same time is accurate and practical.

Naturally the first question that is asked is what is coal? This is answered briefly but thoroughly in the earlier chapters, in which the author tells us how the great coal seams of our country developed from the strange forests of millions of years ago, traces of which can still be seen in the coal itself. Then comes the early history of coal mining, and it is interesting to find that coal must have been used to some extent in this country three or four thousand years ago. No doubt this was outcrop coal, which in the first days of the industry could be dug from the ground without difficulty. As this surface coal was exhausted the miners little by little burrowed their way into hillsides, dug pits or drove shafts into the ground in following up the seams. And then they began the fight with water, which at one time threatened to put a stop to coal mining altogether; with suffocating gas and with fire-damp and dust explosions. Pumps were developed to deal with the first of these dangers, and ventilation, improved lighting and other methods are conquering the others.

The actual mining of those days was crude and involved the greatest hardships for the miners and for their wives and children, upon whom fell the burden of dragging the coal to daylight. The work was hard and the hours long, but gradually the abuses were brought to an end, and machinery has abolished much of the drudgery. All this is well described, and in addition we see how coal has been dealt with at each stage of mining development from the time when it was "sea coal" carried in boats to London and other places, including the Continent.

This account of the winning and distribution of coal throughout the centuries leads to a vivid description of the actual work in a modern mine well equipped with coal cutters and conveyors. We see how the miners make their way to the coal face and what they do there, how the coal is taken to the pit head, how fresh air is supplied, and how the underground roadways are kept safe and in good order. Then we see how the coal is washed and sorted before it is sent away to be put to work. The book ends with an account of the many uses to which it is put. This section will surprise many readers, for to-day the black mineral is more than a fuel; it is the source of many valuable products including fertilisers, explosives, dyes, plastics and even medicines and perfumes, derived from the products of coal distillation.

The book is well illustrated, chiefly with half-tone pictures of work underground and on the surface in

early days as well as in modern times, and there are also excellent diagrams.

## "MECHANICAL ENGINEERING AND WORKSHOP PRACTICE"

By JAMES T. CORNER (Vawser and Wiles, 5/- net)

The first question asked when starting out on a new career is "What tools shall I require?" Here is the answer for those taking up engineering as a profession, or thinking of doing so. It is practical throughout, written in good and easy style by an expert who explains everything from the beginning in such a way that there is no hard struggle to understand what is meant, every detail and trick of the trade being fully explained in its proper place.

The contents of the book show how useful it will be to the budding engineer. It begins with adequate

descriptions of such simple tools as hammers, spanners, chisels, files and hacksaws, explaining the best way to use them. The reading of drawings follows, and then come sections on marking out work, the use of templates and gauges, with descriptions of the making of measuring and marking-off tools, drilling, and the use of taps, stocks and dies.

After this there are sections on the working of metals, including hardening and tempering, and the book ends with an account of the lathe and its uses.

There are 105 illustrations of tools and contrivances of all kinds, showing the best ways of using them.

## "THE A.B.C. OF IRISH LOCOMOTIVES"

By BARRINGTON TATFORD (1/6 net)

This latest addition to the now well-known "A.B.C. Locomotive Series" gives in a handy and compact form the principal details of the locomotives of Eire and Northern Ireland. Beginning with the Great Southern system, the numbers and classes are given of the engines of the main lines, of the standard Irish gauge of 5 ft. 3 in., and of the narrow gauge engines of the various light railway constituent concerns. There is also a table of principal dimensions, showing the date, origin and designer of each class. The same plan is followed for the Great Northern and the N.C.C. or Northern Counties Committee line of the L.M.S., and for various minor systems, both standard and narrow gauge. In conclusion there are details of various industrial and privately-owned locomotives.

There is also a useful map and a good selection of locomotive photographs. Copies of the booklet can be obtained from the A.B.C. Locomotive Books Mail Order Dept., 33, Knollys Road, London S.W. 16; 1/8 post free.

## "TITANS OF THE TRACK, L.N.E.R."

(A.B.C. Locomotive Series, 1/6 net)

Illustrations reproduced from actual photographs of L.N.E.R. locomotives form the bulk of this booklet. They make up an interesting collection ranging from giant streamlined engines of the "A4" class and a mighty "P2" Mikado to "Sandringhams" and "Halls," and various ex-G.C. and other locomotives, including by way of contrast a Stirling "Single," a Titan of other days. A compact and useful summary of L.N.E.R. locomotive history also is given. Copies of the booklet can be obtained from the A.B.C. Mail Order Dept. at the address given above, 1/8 post free.

Owing to wartime difficulties, it is impossible to guarantee prompt delivery of books ordered as described at the head of this page, but every effort will be made to ensure speedy despatch.

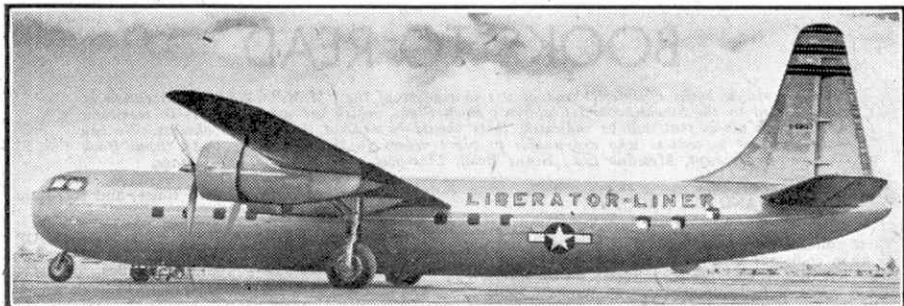

"Liberator Liner," Consolidated-Vultee's 4-engine streamlined transport. It can carry 48 passengers on day service, and 24 when used as a sleeper. Photograph by Consolidated-Vultee through Michael Lorant.

## Air News

### Record U.K.-New Zealand Flight by B.O.A. "Lancastrian"

An Avro "Lancastrian" transport of British Overseas Airways took off from Hurn aerodrome on 23rd April last on a flight to New Zealand that was a preliminary to the opening of a new fast air service between the United Kingdom, Australia and New Zealand. The new service will be operated by the Corporation and Qantas Empire Airways, and is expected to begin this month. The route followed on the introductory flight was by way of Lydda, in Palestine, Karachi, Ceylon, Learmonth and Sydney, in Australia, to Auckland, New Zealand. The long journey of about 13,500 miles was accomplished in the fine time of 85½ hrs.—about 3½ days—of which 24 hrs. were accounted for by stops on the way for refuelling, etc.

The "Lancastrian" carried a crew of eight, with Capt. R. G. Buck, Chief Officer of B.O.A. Development Flight, in command, and the passengers included officials of the Ministry of Aircraft Production, A. V. Roe and Co. Ltd., builders of the aircraft, Rolls-Royce Ltd., makers of the "Lancastrian's" engines, and the Asiatic Petroleum Company.

This fast flight, with only five stops on the way, is an indication of the advance made in long-distance air service operation since pre-war days, when a commercial flight to New Zealand was accomplished in 30 or so stages.

### More Railway Associated Air Services

The first civil air service between London and Scotland since pre-war days came into operation with the recent introduction of the summer timetables of Railway Associated Air Services. The new service is operated by Railway Air Services Ltd. in collaboration with Scottish Airways, between Croydon Airport, London, and Prestwick Airport, Scotland, and is flown in each direction on weekdays. It is intended primarily for transatlantic passengers arriving at or departing from Prestwick.

The London-Liverpool service which Railway Air Services Ltd. have been operating since November last has been retained, and now leaves Croydon at 9.15 a.m., due Liverpool 10.55 a.m. The return trip is made

from Liverpool at 3.15 p.m., and is due Croydon at 4.55 p.m. Air passengers to and from Belfast, Isle of Man, and Douglas connect with the London service at Liverpool. The services between Liverpool and Belfast have been increased to four in each direction, and between Glasgow and Belfast to three in each direction, each weekday.

Scottish Airways announce the introduction of a direct air service between Glasgow and Stornoway on Tuesdays, Thursdays and Saturdays, leaving Renfrew Airport at 11.30 a.m. The service in the opposite direction leaves Stornoway at 2.0 p.m. on the same days of the week. The journey takes two hours. The Inverness-Stornoway air service operated during the summer of last year has been reinstated, with a thrice-weekly flight in each direction. The regular routes from Renfrew to Campbeltown and Islay, and to and from Tiree, Benbecula, North Uist and Stornoway are still in operation.

Although travel restrictions to and from Eire limit the demand, West Coast Air Services Ltd., in conjunction with the Irish Air Lines, are maintaining two services each weekday between Liverpool and Dublin, the air journey being made in 1 hr. 20 min.

The frequency of the service between Liverpool and the Isle of Man has been increased to four flights in each direction every weekday. Flying time is one hour. This service is worked by Isle of Man Air Services, and has proved to be one of the most popular air lines in the country.

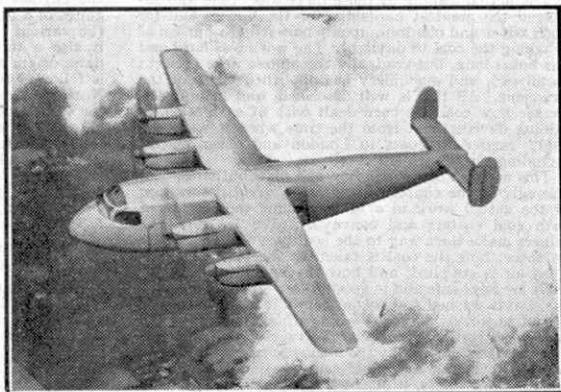

Model of the Miles M-50, a civil transport designed to carry 14 passengers and a crew of two. (See special article on page 185).

### Nove Curtiss Experimental Fighter

An unusual experimental fighter aircraft developed by the Curtiss-Wright Corporation, U.S.A., is shown in the upper photograph on this page. It is designated the Curtiss XP-55, the X standing for Experimental and the P for Pursuit, and is named "Ascender." The new aircraft is a low wing, single-engined and single-seat monoplane, with the engine and wing behind the pilot, while the elevator controls are in the extreme nose; and its rudders are near the ends of the swept-back wing instead of at the rear of the fuselage. The "Ascender" is fitted with an Allison 1,275 h.p. engine, and has a "kick-off" control on its electric 3-bladed propeller, so that the pilot may jettison the propeller in the event of an emergency jump.

Some of the many advantages claimed for this "tail-first" machine are improved longitudinal control and manoeuvrability, better forward visibility, and less noise because the engine is behind the pilot. The guns, being clustered in the nose, fire straight ahead and need not be synchronised to fire through the propeller, nor need their rate of fire be limited.

The Curtiss "Ascender" is one of a number of types developed experimentally in conjunction with the U.S. Army Air Forces Air Technical Service Command which will not go into quantity production, but which are expected to make an important contribution to future aircraft design projects of the A.A.F.

### More New U.S. Air Liners

More new American transport aircraft designed for post-war airline service have been announced. One is the giant Boeing 377 "Stratocruiser" developed from the company's famous B-29 "Superfortress." A military prototype of the 377 has been flown from Seattle, where it was built, to Washington, D.C., a distance of 2,323 statute miles, in 6 hrs. 3 min.,

averaging 383 m.p.h. This fast trip broke the transcontinental record achieved by two N.A. "Mustangs" on 12th May last year when they flew from Inglewood, California, to New York City in 6 hrs. 39½ min. The "Stratocruiser" is a two-deck aircraft planned especially for transocean and transcontinental air

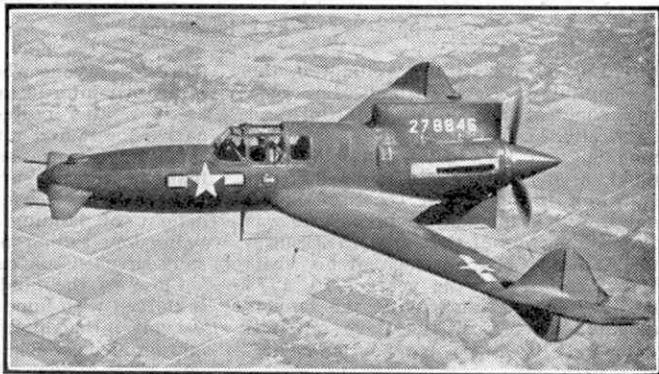

A flight view of the Curtiss XP-55 "Ascender," an experimental "tail-first" fighter, described on this page. This photograph and the one below are by courtesy of the Curtiss-Wright Corporation, U.S.A.

services, and can carry up to 100 passengers. It has a range of 3,500 miles, sufficient to enable it to fly non-stop from New York to London.

The other new air liner is the Lockheed twin-engined "Saturn." Two U.S. airline companies operating "feeder" line services have ordered machines of this type, and production will begin when Lockheed's present military commitments permit. It is a high wing, all-metal machine carrying 14 passengers, a crew of two, baggage and cargo, and has a top speed of 240 m.p.h.

### The Rolls-Royce "Griffon" 65

The Rolls-Royce "Griffon" 65 used in the "Spitfire" XIV is, without a doubt, one of the finest engines in production anywhere in the world. It has a typical "Rolls-Royce" layout, being a liquid-cooled, 12-cyl. upright Vee engine, and is a development of the "K," "Buzzard" and "H" series, which are of 36.7 litres

swept capacity, compared with the 27 litres of the "Merlin." Like the "Merlin" 61 series, the "Griffon" 65 has a two-stage, two-speed supercharger and inter-cooler, which enable the "Spitfire" XIV to operate efficiently at all heights from sea level up to 40,000 ft. To ensure maximum power this supercharger is provided with an automatic change control. The new engine develops over 2,000 h.p., and so has a weight/power ratio of less than 1 lb. per h.p., a fine achievement for a production motor.

In contrast to the "Merlin," which has its camshaft and ignition drives at the rear, those of the "Griffon" are arranged from the airscrew wheel at the forward end of the crankshaft. This feature has done much to reduce the length of the "Griffon" and provide smoother drive. The engine accessories are mounted on a separate gearbox, which is driven by a shaft from the rear of the engine. J.W.R.T.

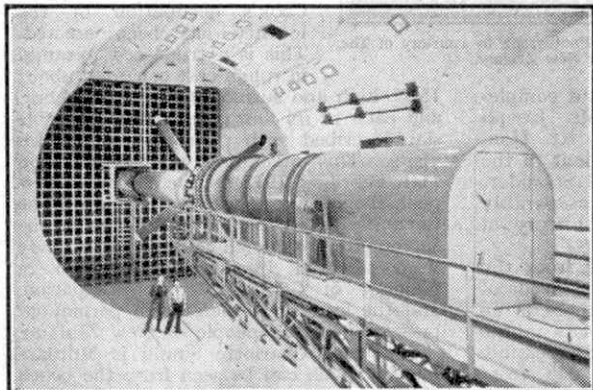

These impressive test facilities of the Curtiss-Wright Propeller Division can test propellers up to 30 ft. long with engines of 5,000 h.p.

# Ship Cove

## Cook's Headquarters in New Zealand

By E. Hawthorne

ABOUT 50 miles from Wellington, the capital of New Zealand, lies Ship Cove, one of the most beautiful and historically interesting spots in the Dominion. It is in Queen Charlotte Sound, a fine inlet 20 miles or more in length on the northern coast of South Island, and is memorable because it was the headquarters of that great Yorkshireman Captain Cook, on each of his visits to that country in the years 1770, 1773 and 1777. On his first visit the famous navigator arrived at the Cove on 15th January 1770, in the bark "Endeavour,"

place for anyone who has an appreciation of historic interest and of natural scenery, as it retains possession of its glorious native forest and must present much the same appearance as it did when Cook first saw it in the summer of 1770, just 175 years ago. One could easily imagine the delight of landing at this lovely spot "after long sailing in deep seas." "A very snug cove," Cook calls it, and so it is.

Close to the landing-place the hillside is clothed with hundreds of big tree-ferns, varying in height from 15 to 30 or 40 ft. and growing right down to the water's edge; this is a sight that can be seen to such perfection in few places, even in New Zealand, which not without justification has been called "the land of ferns." The present day New Zealand military cap badge consists of a crown with two fern leaves on each side.

On the occasion of my visit before the war the Cove was absolutely deserted, the skipper of the launch and myself being the only human beings within many miles. About the centre, a few yards above high-water mark, a permanent memorial of Captain Cook's occupation of the locality has been erected. This is a truncated pyramid in rough-cast concrete, about

15 ft. high and surmounted by an anchor, and each of its four sides bears a marble slab inscribed with particulars of Cook's visits. This memorial was unveiled on 11th February 1913 by the Earl of Liverpool, then Governor of New Zealand. The Cove itself and about 1,800 acres of the surrounding bush-clad country had already been reserved by statute in 1896 in memory of Captain Cook's occupation, and the locality is therefore a permanent possession of the people of New Zealand.

In Queen Charlotte Sound is Motuara Island, which can be seen from the beach of Ship Cove. It was on this island, as well as at Ship Cove itself, that on 31st January 1770, Captain Cook first raised

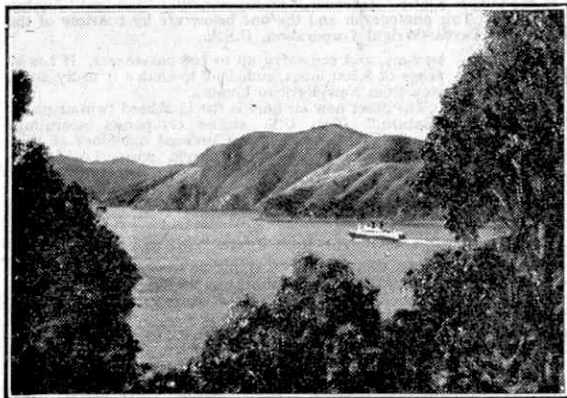

Queen Charlotte Sound, from Picton. Photograph by courtesy of The High Commissioner for New Zealand.

a small vessel of 368 tons with a complement of 94 men, including Mr. Joseph Banks, F.R.S., afterwards the Rt. Hon. Sir Joseph Banks, Bart., President of the Royal Society, and Dr. Daniel Solander, F.L.S., whose names are inseparably associated with the botanical history of New Zealand and Australia.

The Cove is about 21 miles from the small town of Picton, at the head of Queen Charlotte Sound. As there is an almost complete absence of roads in the region of the Sound, access to it is possible only by motor launch, the trip from Picton, at the head of the Sound, occupying about 2½ hrs., a pleasant run in calm and land-locked water. It is a fascinating

the British flag in the South Island of New Zealand, and took possession in the name of King George the Third. Cook thus refers to the incident in his journal: "After I had prepared the way for setting up the post, we took it up to the highest

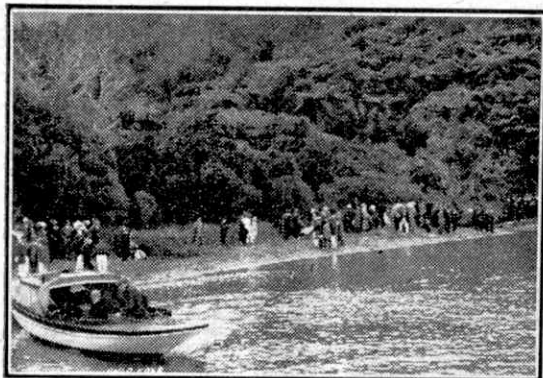

Ship Cove, where Cook made his Headquarters in New Zealand.

part of the Island, and after fixing it fast in the ground, hoisted thereon the Union flag, and I dignified this Inlet with the name of Queen Charlotte's Sound, and took formal possession of it and the Adjacent lands in the Name and for the use of his Majesty."

The creek from which Cook watered his ships still flows merrily to the sea. "We found a fine Stream of Excellent Water," he says in his journal, and goes on to tell how on 2nd February 1770 so heavy a fall of rain took place that it "caused the Brook we water'd at to overflow its banks, and carry away 10 small Casks we had Standing there full of Water, and notwithstanding we searched the whole Cove, we could not find one of them."

Of the many attractive features of Ship Cove not the least is the bird life. On a fine sunny day the bush is filled with the songs of the bell-bird and the tui or parson-bird. Sir Joseph Banks in his "Journal" refers to the bell-bird as follows: "17th January 1770. —I was awakened by the singing of the birds ashore, from whence we are distant not a quarter of a mile. Their numbers were certainly very great. They

seemed to strain their throats with emulation, and made perhaps the most melodious wild music I have ever heard, almost imitating small bells, but with the most tunable silver sound imaginable." On my visit to the Cove the bell-bird was noticeably absent, but the tui was present in large numbers, and his beautiful liquid notes were to be heard almost continuously throughout the day. This bird derives his name of "parson-bird" from two small tufts of brilliant white feathers on his breast, which are highly suggestive of the old parsonical "bands," especially as the rest of his body is clothed in deep and glossy black.

As I stood alone on the beach it was not difficult to conjure up a mental picture of the "Endeavour" at anchor in the Cove, her crew busily engaged in obtaining wood and water while Banks and Solander collected plants and interrogated the natives regarding their cannibalistic propensities. It was here that the scene took place which is so graphically described by Cook: "Mr. Panks got from one of them a Bone of the fore Arm; and to show us that they eat the flesh, they bit and naw'd the bone and draw'd it through their Mouths, and this in such a manner as plainly shew'd that the flesh to them was a Dainty Bit."

On Cook's later visits to Ship Cove during his third and final voyage, he had with him, as Master of the "Resolution," the celebrated William Bligh, who later on in his career was the central figure in the mutiny on the "Bounty."



The Cook Memorial in Ship Cove.

# Of General Interest

## Underneath the Arches

The interesting but somewhat puzzling photograph reproduced on this page was taken "underneath the arches" of the Ouse Viaduct, on the main London to Brighton line of the former London, Brighton and South Coast Railway, now part of the S.R. The viaduct crosses the valley of the Sussex Ouse and consists of 37 semi-circular brick arches varying in height from some 40 ft. at the abutments to 90 ft. or more where the river itself is crossed. It was built to the designs of John Urpeth Rastrick, a pioneer railway engineer, and was opened for traffic on 12th July 1841, but complete communication by rail from London to Brighton was not afforded until 21st September of the same year.

The viaduct has an extremely fine appearance owing to the slender proportions of its supporting piers, its neat arches and a pleasing "openwork" parapet. A curious feature is that each of the piers, which taper inward very beautifully as they rise upward to the arches, is built with an oval space in the centre, and it is the view through these spaces that is seen in our illustration. Rastrick designed his viaduct well, for its fine lines have not prevented it from bearing successively heavier loads during the century of its existence. It is said that 11,000,000 bricks were used in its construction, and it cost £58,000.

## Bouncing Putty

If you drop a piece of putty on the ground it just flattens out without bouncing at all. If you try to squeeze a hard rubber ball into a different shape it might give a little, but the rubber just returns to its original form when the pressure is released. Putty in fact can be shaped but not bounced, while hard rubber can be bounced but not shaped by mere pressure. It seems difficult to imagine anything that can be like putty and also like hard rubber, yet there is a material of this kind, which is actually known as "bouncing putty" because it is both elastic and plastic.

This very strange material was discovered when experiments were being made to develop a new type of artificial rubber containing the element silicon, which is best known in the form of its oxide, familiar to all of us under the name of sand. How it behaves depends on the rate at which pressure is applied to it. Under persistent slow and steady pressure parts of the material begin to slide over others and in this way it can be shaped like putty. On the other hand a sudden sharp application meets with instant resistance—and the "putty" bounces! There are a few other substances that act in this strange manner to a limited extent, but silicone putty is the first in which the two properties are so clearly marked.

## Glass Without Sand

For centuries we have been accustomed to the use of sand in making glass; now a glass is being produced in which no sand is used at all. This is the result of a search for a glass that is not attacked by hydrofluoric acid, one of the most terrifyingly corrosive liquids known. It is actually used for etching glass, and until recently it could be kept only in bottles of gutta percha, lead or wax. More and more applications are being found for the acid in manufacturing processes. Containers less cumbersome and costly than those already in use were wanted, and this glass without sand was found to meet the need.

The chief ingredient of the new glass, replacing sand, is a strange chemical called phosphorus pentoxide. This is the white substance formed in clouds when phosphorus burns, and it is so eager to take up water that throwing it into this liquid produces an action so violent that it is almost explosive. The glass made from it is like ordinary glass in appearance, and can be cast into sheets or blown into bottles and other shapes in exactly the same way.

## A Problem in Exact Measurement

How would you measure the diameter of a wire that is only a few millionths of an inch across? This is a problem that had to be solved in producing very fine wires for supporting tiny mirrors in delicate electrical measuring instruments. It was solved by laying pieces of the wire in grooves cut in a plastic that had been partially set by heating. The grooves were filled in with more of the plastic, and the mass finally was heated to complete the setting, leaving the wires firmly embedded. Then the block was cut across at right angles to the grooves, so that the cut faces showed the cross

sections of the fine wires as tiny dots. Finally thin slices showing these dots were placed under microscopes that had micrometer scales in their field of vision, and their diameter was carefully measured.

It was necessary to embed the wires in the plastic material in order to avoid damaging the sections when they were cut. Merely to cut the wires by any means would have torn and mangled the ends so much that exact measurement would have been impossible.

## World's Deepest Oil Well

The world record for oil well depth appears to belong to a well in Texas owned by the Phillips Petroleum Co. As far back as last April this had penetrated to a depth of 15,255 ft., and it was still being driven downward, so that by this time it must be considerably over three miles deep. The mud lubricating the cutting tool makes a round trip of about six miles.

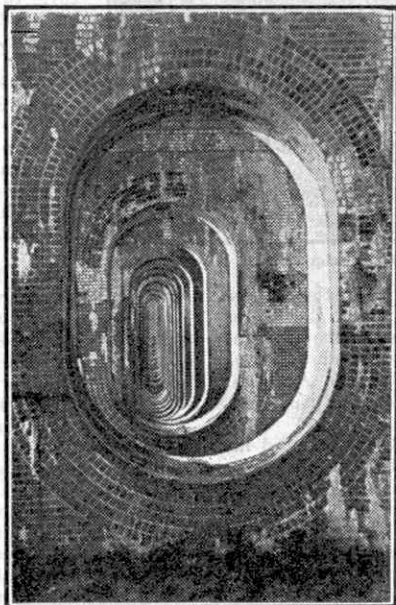

Looking through the arches of the Ouse Viaduct, on the London-Brighton line of the S.R. The piers have oval openings in them, and our illustration shows the view through these along the length of the viaduct. Photograph by W. S. Garth, Preston.

# The Fairchild "Packet"

By John W. R. Taylor

**I**N the article on Fairchild aircraft in the October 1944 "M.M." brief reference was made to the new C-82 transport which Fairchild's promised would incorporate "some unusual features not found in present aircraft used for similar purposes." Well, the C-82 "Packet" took off for the first time on 10th September 1944, and several details of this unorthodox but promising transport may now be published.

The "Packet" is often called the "Flying Boxcar," and that is just what it is. Nobody would attempt to call it handsome, but it was designed to do a job of work and indications are that it does it well. In general layout it is similar to the German Gotha 242 transport glider. Like the Go. 242, the "Packet" is a large twin-boomed aircraft, with its square-section fuselage slung under the 106 ft. span wing. This feature, together with the tricycle undercarriage, has enabled the designers of the "Packet" to make the floor of the fuselage parallel to the ground and only four feet above it. The rear portion of the fuselage consists of two large doors which hinge open sideways, and loading ramps are carried inside the aircraft. Thus loading is greatly facilitated and every inch of the 2,312 cu. ft. of cargo space is utilised, as quite large

vehicles, including 2½-ton lorries, armoured cars or M-22 tanks, can be driven under the booms and tailplane, straight up the ramps into the cargo compartment. In

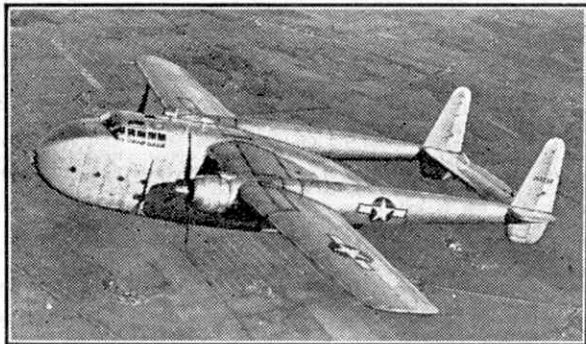

The Fairchild C-82 "Packet" transport. Photographs by courtesy of the Aircraft Division of the Fairchild Engine and Airplane Corporation, U.S.A.

the more conventional method of loading through side doors, the fuselage must be wide enough to permit the vehicles to turn on entry, which consequently restricts their size.

The nacelles for the two 2,400 h.p. Pratt and Whitney "Double Wasp" engines form the forward portion of the tail booms and also house the main wheels when the undercarriage is retracted. The "Packet" is a "clean" aeroplane from the aerodynamic standpoint and, consequently, has a quite good performance. But the only figure that may be quoted at the moment is its range of 3,500 miles at an all-up weight of about 42,000 lb.

Apart from its normal duties as a cargo transport, the "Packet" can also be adapted as a troop or paratroop transport with accommodation for 42 men, an ambulance fitted out to carry 34 litters and four attendants, or a glider-towing aircraft. It is now in big-scale production in the new Fairchild factory at Hagerstown. In addition it is being built by North American Aviation Inc. These aircraft are destined for military service with the U.S.A.A.F., but Fairchild's are now working on the design of a "luxury liner" version with accommodation for 50 passengers for the post-war airlines.

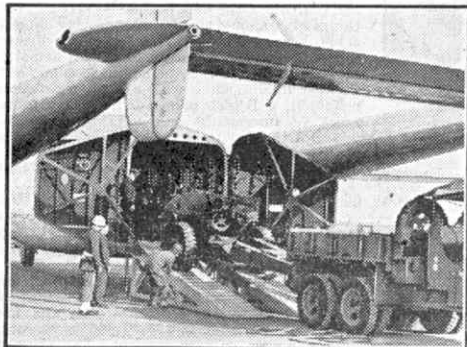

A howitzer being loaded into the "Packet."

## HOW THINGS ARE MADE:

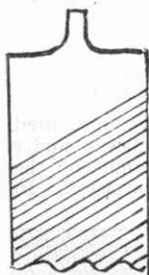

Fig. 1.

we will begin the story with the steel of which the file is made. This is a good quality crucible carbon steel, usually having about 1.2 to 1.4 per cent. of carbon in its composition, with 0.1 to 0.13 per cent. silicon. Some files are made of steel with a lower carbon percentage, but this is not a good thing unless the file is extremely well made in other directions, which it seldom is. The rule for a sound Meccano boy is buy *new British files*.

The steel is cast into ingots, hammered or rolled by stages down into bars of shapes in sections corresponding to those of the files to be made from them. Then the bars are cut up into small lengths known as 'file moods.' These are passed in quantities to the file forging shop, where they are heated up in a gas furnace to the right temperature. The first job is to make the pointed end of the file that is eventually driven into the wooden handle. This pointed end is called the 'tang.' The result of heating is the

## Files

By Eric N. Simons

EVERY mechanically-minded boy has had occasion to use a file, but not all of them have troubled to take a magnifying glass and look through it at the tiny little teeth that make the file one of the most effective cutting instruments in engineering. How did those teeth get there? A number of intricate processes were required, and

gas or electric. Another advantage of annealing is that it takes away from the metal all the strains that have been developed in it by the earlier heating and forging operations. The process requires about 24 hours.

Whenever a carbon steel is heated, it tends to become slightly warped or distorted, and this is true of file blanks, so that after annealing they are carefully heated and straightened by hand forging with an ordinary hand forging hammer. However modern the heating furnace, as soon as steel comes when red or white hot into direct contact with the air, some oxidation takes place and a scale is formed on the steel's surface. This must be removed before any cutting is done on it, as otherwise the cutting chisel would do part of its work on this soft skin or scale. Then, when the file was put to work, this soft portion would flake away, and leave behind a blunt and badly formed file tooth. Consequently, all scale must be removed by grinding. Small files may be ground either by machine or by hand, but larger files are always machine ground.

The files are placed in a row of from eight to ten in a water-filled trough, carried by a table which is driven backwards and forwards under a revolving grind-stone measuring often as much as five feet in diameter and a foot wide. The machine is practically automatic in action. Not all files can be ground in this way, but the exceptions need not trouble us.

The surface of the steel has to be perfectly smooth so that when teeth are cut in it, each tooth is of the same height as the rest. This result is obtained by subjecting the blanks after they have been ground to a process known as 'draw-filing' or 'stripping.' The blanks are laid down in holders and held by their tangs, all in a row, while the file used for smoothing their surfaces is drawn back and forth over them. The holders are pressed upwards by levers and weights against the file blanks. In the more modern works draw-filing is now eliminated for reasons too technical to be enumerated here.

Every good file manufacturer stamps his name and brand or trade mark on the shoulder of the file, near where the tang begins. It is one of the things a boy should look for when buying himself a file, because it tells him whether the maker is proud enough of his work to put his name to it, and if the name is there, he can soon find out whether it is a name with a good reputation behind it, a British name, and, in fact, quite a lot of interesting and important things.

The 'marking' of the file, as it is called, is sometimes done after the draw-filing, and sometimes after the cutting. A press is used to force the marking tool into the file.

Most files are cut to-day by machinery. A fine and even cut and spacing of teeth are secured. When small and delicate files are being cut, the motion of the cutting tool in the cutting machine is so swift that the eye cannot distinguish the separate blows. Whatever kind of machine is used, the strokes are made by a high speed steel cutting chisel which is caused to deliver blows on the surface of the file blank at the rate of from 700 to 1,800 a minute, depending on the size of file being cut. The edge of the cutting chisel has to be kept extremely sharp or the cut teeth will not be fine enough, and in

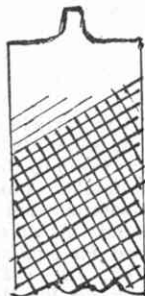
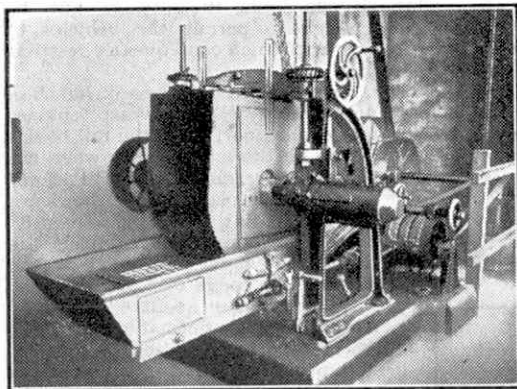

Fig. 2.



File Grinding Machine.

formation of a flaky skin of oxide on the surface of the steel, and this must be mechanically or otherwise blown off to prevent it from being forced into the hot surface of the steel, unless the heating furnace is of the latest type designed specially to prevent this oxidation.

The forging hammers used are not very large, and are as a rule worked by one man. The tang having been formed, the file is then made into its proper file shape. It is now termed a 'blank' before the fine teeth can be cut into it, it has to be softened by a process known as annealing, which means heating the blanks in a furnace and letting them slowly cool down in the furnace. This makes the steel more ductile, so that it does not resist the edge of the cutting chisel. The furnace used is either



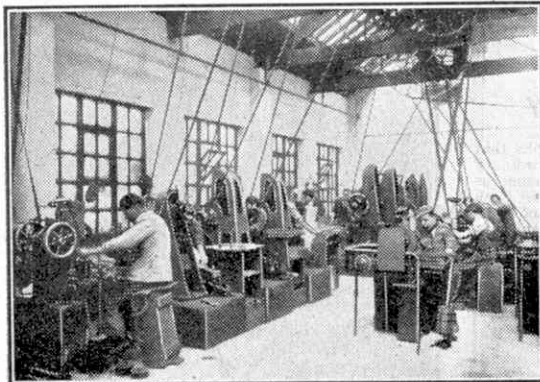

Cutting Files.

addition, the chisel itself has to be at an angle of about 55 degrees to the surface of the blank. This is because in this way a much better shape of tooth is obtained than if the chisel simply struck up and down vertically.

The strokes of the chisel have to be of the same force every time, to keep the teeth uniform in height, and the machine is so designed as to ensure this automatically. The file blank is fastened down to a movable bed which moves forward a little with every blow of the chisel so that two cuts are never made on the same place, but are evenly spaced out. The worker can vary the spacing of the teeth if required, or the force of the chisel blow, or the angle of the cutting strokes to the edge of the chisel.

File blanks are left rather long at the tip of the file so that in cutting, the machine can get a better start from the rest, and by the time it reaches the point at which the file proper begins, it is cutting evenly. The extra metal at the tip is afterwards sheared off, and the rough edge is ground smooth again.

Some files, technically termed 'float' files, have teeth running from one edge of the file to the other, as in the sketch, Fig. 1. More often, however, two cuts are given, at angles of from 40 to 45 degrees with the axis of the file in one instance, and 70 to 80 in the other. The first cut is called the over cut, and the second, the up cut. See Fig. 2. If the file has only the over cut, it rasps rather than cuts away the metal being filed, and the surface filed will be rather rough and harsh. For smoother filing the two cuts are necessary, and the action of the teeth is a proper cutting or shearing action, not just a rasping.

Having been cut, the files have next to be cleaned to rid them of any dirt picked up during cutting, e.g., oil or grease from the machine. This is done by scrubbing them with a wire brush. They have now to be hardened, as otherwise they would be too soft to do their work. To prevent the file teeth from being damaged by the molten lead in which the files are heated, they are given a coating of thick paste, this paste being composed of charcoal and flour, or some similar blend. The paste covers the teeth and the spaces between them and when heated gently, it hardens and stops the lead from sticking to the steel, which means that the file teeth will not get burned, melted, or made soft by withdrawal of the carbon they

contain from them.

The files are now placed in a heat-resisting metal pot full of molten lead, covered on the surface with a layer of wood charcoal, coke, or some other material containing plentiful carbon. This covering is designed to stop the lead from being wasted by contact with the open air, which oxidizes and spoils it. Steel is lighter than lead, so when files are plunged into a lead bath, they bob about like corks, a sight that has, as the writer knows from experience, puzzled and fascinated many a school-boy seeing it for the first time. To stop this, the pot is bridged by a flat iron bar, and the tangs of the files are made to rest against the underside of this bridge, which prevents them from bobbing out of the lead to a greater extent than is desired.

When the file has been heated by the lead to the right temperature, it is taken out and plunged into a great tank of brine to quench it. It is this quenching that gives the steel its hardness. As each file is taken out of the lead bath, another is introduced in its place.

There is a curious point that few boys would notice unless their attention were drawn to it. If you watch the hardener as he plunges the white hot file into the brine tank, and moves it about in the water to cool it, you will see that if the file is of one shape, he gives it a particular movement through the water. If it is of another shape, he gives it a different motion. In fact, he has a different motion for every shape of file. Why is this?

The answer is that when hot steel is quenched, the fierce heat turns some of the water into vapour. If the file were simply held quite still in the water until it had cooled, the vapour in the form of little pockets or bubbles would collect on the surface of the file, and being hotter than the cold brine solution, would stop the drastic cooling action from reaching those surfaces they covered. As it is the drastic cooling that gives the hardness, it should be obvious that these places would not be so hard as the rest, where there were no vapour bubbles. Consequently when the file was put to work, it would be found to have a considerable number of soft teeth, and might have to be scrapped. Consequently, the file hardener keeps the file moving so as to shake off all these bubbles and pockets of vapour, and the different motions are intended to suit the different shapes of files. The motion that would drive the bubbles from one shape might be just that (Continued on page 214)

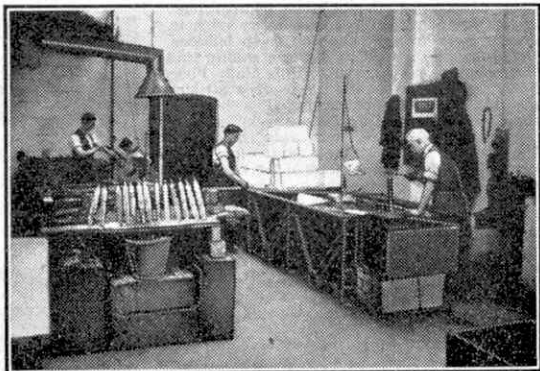

Hardening Files.

# Photography

## Pictures against the Sky

ON this page we reproduce three photographs that have been selected to show how quite ordinary subjects can be photographed in such a manner as to produce really beautiful and artistic effects. Each of the photographs was taken with the sky as background, and I think readers will agree that this has added beauty and character to the pictures.



"Pals." A charming picture by P. W. Lang, Sevenoaks.

There are of course hundreds of subjects that look their best when thrown into relief against a pleasing sky, but it is not always easy to find a viewpoint from which they can be photographed in this way. On the other hand many subjects, among them trees growing on steep hillsides, windmills, and castles on hilltops, readily lend themselves to photographs of this kind. Flags flying at mastheads also make very striking pictures, especially if caught at a moment they are silhouetted against a background of billowy white clouds and deep blue sky. Usually it is quite a simple matter to find a viewpoint from which subjects of this kind stand out boldly against the sky.

In other cases the desired effect can be got by placing the camera as near as possible to the ground or by taking advantage of variations in the ground level. This was done in photographing the boys and their dog shown on this page, a low viewpoint for the camera with the subjects grouped on a slight rise in the ground, combining to give the required effect.

Photography against the sky is quite easy provided that a few simple precautions are taken. It must be remembered that the effect of these pictures is greatly enhanced by good rendering of the clouds and in order to make

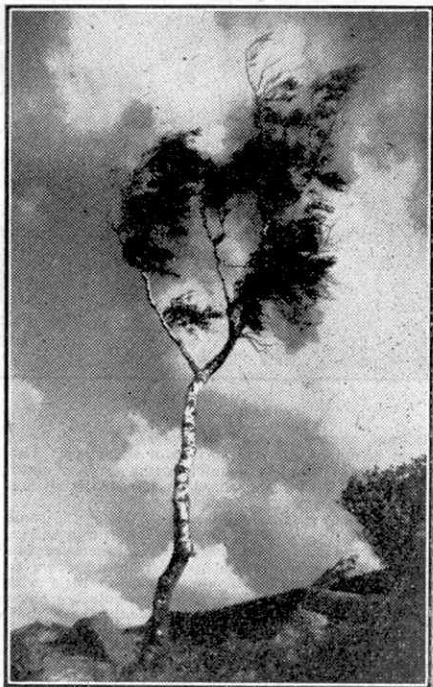

"Silver Birch in the Gale." A fine "against the sky" picture by A. C. Atkins, Eccles.

the clouds stand out against the blue sky a panchromatic film must be used, and if possible a yellow light filter over the camera lens. A film that is not colour-sensitive records the blue sky almost as brightly as the clouds, so that the necessary contrast is lost. A panchromatic film makes use of the coloured components of the light from the clouds in such a way as to render the clouds more brightly, while the filter subdues the light from the sky.

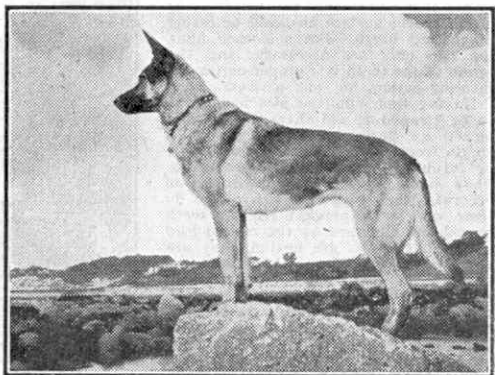

"The Alsatian," by John T. Semple, Edinburgh.

# From Our Readers

*This page is reserved for articles from our readers. Contributions not exceeding 500 words in length are invited on any subject of which the writer has special knowledge or experience. These should be written neatly on one side of the paper only, and should be accompanied if possible by original photographs for use as illustrations. Articles published will be paid for. Statements in articles submitted are accepted as being sent in good faith, but the Editor takes no responsibility for their accuracy.*

## ANOTHER HOUSE-BUILDING RECORD

While I was in Hamilton, Ont., Canada, in 1913, the City celebrated its completion of 100 years of growth. During the week set apart for the celebrations a city contractor built a house in 17 hrs., so beating the time of the Preston builder whose work was described in the February "M.M." This house was built in a sports field and every purchaser of a ticket of admission was entitled to guess the number of beans in a huge glass vessel, the winner becoming the owner of the house. This was then sold by the winner, and the new owner moved it across the field and out through the surrounding fence to a site on an adjoining avenue, where I presume it still is. Incidentally this house was furnished and visitors were allowed to roam through the rooms.

The accompanying illustration conveys some impression of the bustle that accompanied such an effort. The house was made of concrete blocks, with the upper storey of timber, and shingles, or wooden "slates," form the roof. Note the surrounding poles for electric light connections, which allowed the workers to continue until the job was completed in the specified time. The house was much larger than the one at Preston, but more men were employed in its erection.

R. JOHNSTONE (Stevenston).

## AN AMPHIBIOUS HIGHWAY

Only an amphibious tank could follow the road indicated by the milestone on the accompanying picture, taken at Kent's Bank, in the Furness district of Lancashire. It is a relic of the days when coaches were driven across the sands of Morecambe Bay in preference to the longer route over the swamps and mosses at the head of the bay. The route was only passable at low tide, and even then great care was needed to avoid the many channels and patches of soft sand. Many tragedies befell travellers making the crossing, and the churchyard at Cartmel contains over 100 graves of people who lost their lives in this way.

So important was the route in olden times that the Prior of Cartmel appointed a guide for the assistance of those who wished to make the crossing. His job was to reconnoitre the route three times a week to locate the sandbanks, channels and currents, which are constantly changing. The last official guide died at Grange a few years ago.

J. R. THWAITE (Wollaton).

## CYCLING TO TIMETABLE

I am fond of cycling in moderation—20 to 30 miles is a long ride for me—and as my bicycle is

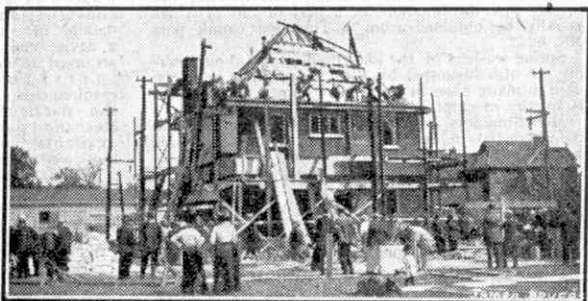

A house built in 17 hrs., as described on this page.

fitted with a cyclometer I started timing and measuring all roads when out on a ride. The fascination of being able to go for a ride and to know to the minute what time I should arrive at, say, a distant village, or back home again, soon took hold of me, and I consequently set about systematically covering

every road within a radius of about 10 or 12 miles of my home. Then I worked out timetables. The routes planned include every road at least once, and are numbered in the same way as bus routes. There are 53 in-all and slips have been made out for each with timings at places on the routes. These I keep on a piece of plywood, cut to size, with a piece of celluloid on the top, and elastic bands hold them together. They slip easily into my pocket. On each trip I have with me the slips for the whole of the area and on setting out I place at the top the slip relating to the particular section of the road to be traversed. It is then quite easy to pick out any slip that I may need later in the course of a ride.

This plan has added a lot of interest to my rides and I have visited many out-of-the-way villages and found much beautiful scenery that I might otherwise have missed. Incidentally I might mention that in pre-war days I could leave home at the same time as a London-Birmingham 2-hr. express left Paddington, and arrive at Fenny Compton Station, nearly 13 miles distant, just as the train was being "pegged" 71 min. later.

M. SMITH (Daventry)

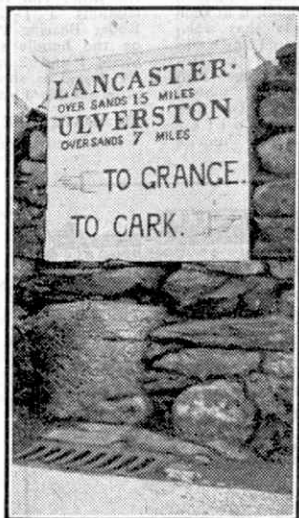

Direction signs to an amphibious highway crossing Morecambe Bay. Photograph by J. R. Thwaite, Wollaton.

# Among the Model-Builders

By "Spanner"

## READER'S SUGGESTIONS FOR NEW MECCANO PARTS

Michael Bleckwen, Feltham, has been busy thinking out ideas for new Meccano parts. Among them is a  $1\frac{1}{2}$ " Strip having three holes, the centre one being threaded. He thinks such a part would be useful in model vices. Unfortunately the thickness of a Strip is not sufficient to take a thread satisfactorily, and in any case the functions of a part of this type can usually be obtained from a Threaded Crank part No. 62a.

Spring washers of the kind used in actual engineering are also suggested by Bleckwen. These could be used in many cases in place of lock-nuts, and the idea is worthy of careful consideration.

Model-builders keen on architectural models will be interested in another of Bleckwen's suggestions which concerns small windows made of celluloid or plastic material and available in the same sizes as Flexible Plates Nos. 188 and 190. These windows would have the standard holes around their sides and ends to allow them to be built into models. The idea has possibilities and I should like to hear the views of other model-builders on the matter.

## AN IDEA FOR CRANE BUILDERS

Derrick Sewell, Horsforth, near Leeds, thinks "M.M." readers will be interested in a novel mechanism he constructed recently. It is a speed-retarding device designed specially for preventing an electric motor from "racing" when the load upon it is reduced or withdrawn. It might be used, for example, in a Meccano crane mechanism. The device makes use of a Meccano Resistance Controller, which is wired in circuit with the Motor. The lever of the Controller is coupled to the operating lever of the crane clutch mechanism in such a way that when the clutch is released, so removing the load from the motor, the Resistance Controller lever is moved

simultaneously across to the minimum speed position, thus slowing down the motor.

Readers will realise that the actual constructional details of such a device can be arranged to suit individual requirements and the particular Meccano parts available, and those who possess a Resistance Controller should bear the idea in mind.

## A MECCANO RATTLE DESIGNED BY "PAWL"

The frame of the rattle consists of Strips and Double Angle Strips and it is held in place on the Rod forming the handle shaft by means of Collars. A Flexible Plate is fixed by Angle Brackets to one end of the frame, and the other end of the Plate contacts a 1" Gear or a Roller Bearing Pinion 3 fixed on the handle shaft. Short Strips 1 and 2 are bolted to the frame as shown and bent slightly so that they

"Pawl's" Victory Rattle built in Meccano.

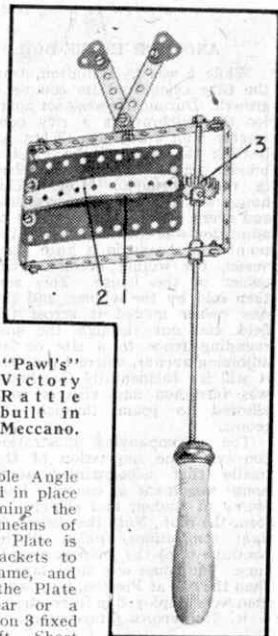

## AN ADAPTABLE INTERMITTENT CAM MOVEMENT

Advanced model-builders on the look-out for novel mechanisms will be interested in the unusual cam device shown at the foot of the facing page. This is a reproduction in Meccano of an actual mechanism designed to impart an intermittent lifting movement of variable extent to a lever arm 2, which in turn is used to operate the "feed" mechanism of a machine tool.

Once during each revolution of a driving shaft 1 the lever arm 2 is raised by the actions of cams 3 and 4. The mechanism is designed in such a manner, however, that the "lift" given to the arm during every ninth revolution of the shaft is double that given to it during the preceding eight revolutions.

The driving shaft 1 carries a 1" Gear, a  $\frac{1}{2}$ " fixed Pinion 5 and a 57-teeth Gear 6. There are also on this shaft the two cam wheels 3 and 4. Cam 4 is a Bush Wheel to which is bolted a Pawl to form the cam, and it is fixed to the 57-teeth Gear 6 by two  $\frac{3}{4}$ "

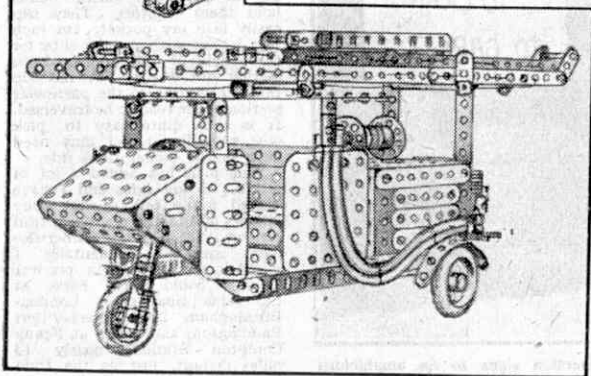
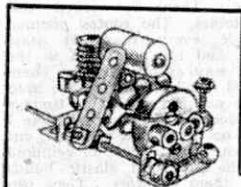

A neat and clear drawing of a model A.R.P. fire engine by A. Grant, Aberdeen.

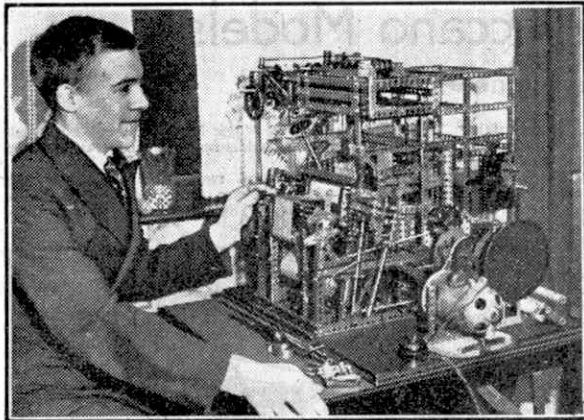

A fine Meccano Loom that weaves real patterned cloth of excellent texture. It is seen with its builder S. Coates, Pudsey, Nr. Leeds, who constructed the model some time ago.

Bolts. The Bolts are lock-nutted in the Gear and the Bush Wheel is held on them between nuts as shown. This complete cam unit revolves freely on shaft 1. The cam 3 also consists of a Bush Wheel and a Pawl, but is fixed to the shaft.

The  $\frac{1}{2}$ " Pinion 5, which is fixed to the shaft, meshes with a 57-teeth Gear 7 mounted on a Rod journalled as shown. This Rod carries also a  $\frac{1}{2}$ " Pinion 8 that meshes with the 57-teeth Gear fixed to the cam wheel 4. The Pawl of the cam 4 is arranged to project sufficiently beyond the rim of the Bush Wheel to give twice the lift of the Pawl on cam 3.

The lever 2 is a Strip that carries at its inner end a  $\frac{1}{2}$ " Bolt on which are mounted two  $\frac{1}{2}$ " loose Pulleys to form rollers that contact the cam wheels. The Pulleys are free to turn on the Bolt and are spaced the right distance from each other by Washers.

When the mechanism is in operation the cam 3 rotates with shaft 1, transmitting lifting motion to the lever 2 through its respective roller. The Pinion 5 transmits rotative motion to the cam 4 through the Gears 7, 8 and 6, the cam 3 in turn transmitting motion to the lever through the other roller.

As the gear train formed by the gears 5, 7, 8 and 6 has a ratio of 9:1 in relation to the speed of the shaft 1, the cam 4 acts on the lever only once in every nine turns of shaft 1. Thus the lever is given eight movements or lifts by the cam 3, followed by a lift of double the height imparted by cam 4 on the ninth rotation of the driving shaft. I shall be interested to hear from any model-builders who find uses for this mechanism.

#### SPECIAL NOTE

"Spanner" will be glad to receive at any time contributions from readers suitable for inclusion in "Among the Model-Builders." All material he is able to use will be paid for at the usual rates.

Contributions may deal with readers' model-building experiences, suggestions for new Meccano parts, or any other topic of interest to Meccano users. Contributions should whenever possible be accompanied by photographs or sketches suitable for reproduction. If sketches are sent it is best to draw them in black ink.

Reproduced on the previous page is a sketch drawn by A. Grant, Aberdeen, of a model A.R.P. three-wheel fire engine, which he built some time ago. The model is itself an interesting piece of work, but my main purpose in reproducing the sketch now is to give readers who intend to contribute to these

pages, an idea of the type of sketch suitable for illustrating their ideas.

Photographs of model-builders themselves, if possible taken with one of their Meccano models, will also be welcome and will be reproduced in the "M.M." as opportunity allows.

#### PUNCHING HOLES IN CARDBOARD

Owing to shortage of Flexible Plates many model-builders make use of cardboard for filling in spaces in the framework of their models, and fix the material in place by bolts passed through perforations made in its edges. The simplest way of boring holes in cardboard is to use a Bradawl, but the finished hole is not very neat. A better plan is to make a template or guide from Strips and place the material between this. The holes can then be punched with a Meccano Rod without tearing the cardboard.

An alternative method is to obtain a piece of tubing having the same outside diameter as a Meccano Rod, and to file one end of it to a sharp edge. A tool of this kind eliminates the need for a template.

#### "PAWL'S KORNER"

"'Ello chaps. What do you think? I've bin let down by the Huns packin' in so soon and there miserable failure to carry on for a nother few weeks has badly mucked up my plans. Cos why? Well, I'll tell yer. Since I rote in these pages last month I've bin busy bldin a Meccano Rattle to selibrate the grate day with, and I wanted to get a pitcher of it in the 'M.M.' in time for you fellers to bild one for yoreselves. However, Jerry's beat me to it, but in spite of the fact that he couldn't wait a bit longer for me I have assed 'Spanner' to put my pitcher in this month just the same. Yule find it on the opposite page. Ope you'll like it. Anyway bild one up and keep it for the final Victory Day, witch we shall surely selibrate when the Jap Gang sign on the dotted line just like Jerry. In the meantime you can use it to spur on yore favourites in the skool sports."

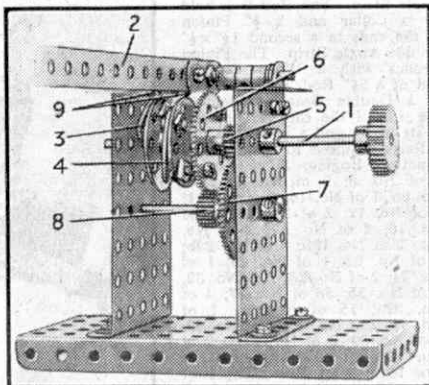

An adaptable cam mechanism that transmits intermittent motions of different extent to a single lever arm.

# New Meccano Models

## Traction Engine—Trick Tricyclist

FIG. 1 shows a neat model traction engine of a simple and easily constructed type. In building it a Flat Trunnion 1, fitted with two  $5\frac{1}{2}$ " Strips, is bolted to each side of a Boiler to provide support for two  $3\frac{1}{2}$ " x  $2\frac{1}{2}$ " Flanged Plates that form the sides of the cab. The rear flanges of these Plates are joined by two  $2\frac{1}{2}$ " x  $1\frac{1}{2}$ " Flexible Plates overlapped two holes. Two Double Brackets 2 are bolted to the back of the cab, and their free ends are joined by two  $1\frac{1}{2}$ " Strips overlapped two holes. The Bolts that hold the  $1\frac{1}{2}$ " Strips carry also two  $2\frac{1}{2}$ " Strips bent so that their lower ends touch the bottom of the cab.

The engine cylinder 3 is a Channel Bearing bolted in position four holes from the front of the Boiler. It is fitted with a piston rod consisting of a  $1\frac{1}{2}$ " Rod, and this slides in the elongated holes of two Angle Brackets bolted inside the cylinder. The rod is attached pivotally by a Collar to a  $2\frac{1}{2}$ " Strip, the free end of which is fastened by lock-nutted Bolt 4 to a Bush Wheel fixed on the end of a  $1\frac{1}{2}$ " Rod. This Rod is supported in a Cranked Bent Strip fastened to the side of the cab by an Angle Bracket, but spaced from the Bracket by Washers. The  $1\frac{1}{2}$ " Rod carries on the inner side of the Cranked Bent Strip a  $1\frac{1}{2}$ " Pulley 6, and at its other end a  $1\frac{1}{2}$ " Pulley 7. The Pulley is connected by a Driving Band to another  $1\frac{1}{2}$ " Pulley on the back axle.

Two  $1\frac{1}{2}$ " x  $1\frac{1}{2}$ " Angle Brackets 8 are fixed to the front of the Boiler, and support a  $2\frac{1}{2}$ " Rod as shown. The Rod carries two  $3\frac{1}{2}$ " Flanged Wheels to represent a dynamo, Washers being used as packing pieces. On one end of the Rod there is a  $1\frac{1}{2}$ " Pinion and on the other a  $1\frac{1}{2}$ " loose Pulley and a Collar. The Pulley is connected by a Driving Band to Pulley 6.

Bearings for the front axle are provided by a  $1\frac{1}{2}$ " x  $1\frac{1}{2}$ " Double Angle Strip attached by a lock-nutted Bolt to the underside of the boiler. Cord is tied to one end of the Double Angle Strip, wound around the  $2\frac{1}{2}$ " Rod 9, and then tied to the other end of the Double Angle Strip. The Rod 9 is held by a Collar and a  $1\frac{1}{2}$ " Pinion in the ends of a second  $1\frac{1}{2}$ " x  $1\frac{1}{2}$ " Double Angle Strip. The Pinion meshes with a Worm on the end of a  $3\frac{1}{2}$ " Rod, which rotates in a Double Bracket fixed to the side of the cab, and carries at its upper end a fast Pulley.

Parts required to build model Traction Engine: 8 of No. 2; 3 of No. 3; 7 of No. 5; 2 of No. 6a; 1 of No. 10; 3 of No. 11; 7 of No. 12; 2 of No. 12a; 3 of No. 16; 2 of No. 17; 2 of No. 18a; 2 of No. 19b; 2 of No. 20b; 4 of No. 22; 1 of No. 23; 1 of No. 24; 2 of No. 26; 1 of No. 32; 1 of No. 35; 58 of No. 37; 4 of No. 37a; 15 of No. 38; 1 of No. 44; 2 of No. 48; 2 of No. 53; 4 of No. 59; 3 of No. 111c; 2 of No. 126a; 1 of No. 160; 1 of No. 162a; 1 of No. 162b; 1 of No. 163; 1 of No. 176; 2 of No. 186; 2 of No. 188; 2 of No. 191; 2 of No. 192.

The Trick Tricyclist shown in

Fig. 2 is driven by a Magic Motor. When this is set in motion the figure pedals furiously and travels along at great speed!

To begin construction two Trunnions are bolted together, and to them are attached two  $2\frac{1}{2}$ " Strips and two  $5\frac{1}{2}$ " Strips. The  $5\frac{1}{2}$ " Strips are bent out-

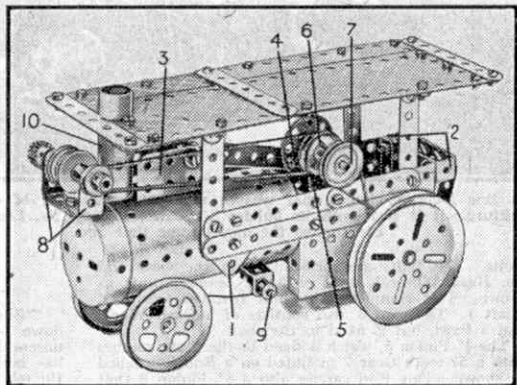

Fig. 1. A working model Traction Engine that is easy to build and realistic in appearance.

ward, and spaced apart by a  $2\frac{1}{2}$ " x  $1\frac{1}{2}$ " Double Angle Strip. A  $3\frac{1}{2}$ " Rod 4 is passed through the end holes of the Strips, and to it a  $1\frac{1}{2}$ " Pulley and two  $1\frac{1}{2}$ " Pulleys complete with Rubber Rings are fitted.

The front wheel is fastened on a  $2\frac{1}{2}$ " Rod 1. The handlebars are mounted on a Reversed Angle Bracket, and are spaced from it by a nut and two Washers. The Magic Motor is then bolted to the  $2\frac{1}{2}$ " x  $1\frac{1}{2}$ " Double Angle Strip at the rear of the tricycle.

The rider's body consists of three curved Plates bolted together to form a cylinder, and to the upper end of this two Flat Trunnions are fixed by means of Angle Brackets.

An Angle Bracket is fixed to the  $1\frac{1}{2}$ " Pulley 2 by a bolt and two nuts, and another Pulley also carrying an Angle Bracket is fixed to the other end of the Rod. Each of the cyclist's legs consists of two  $2\frac{1}{2}$ " Strips bolted so that they are free to pivot and then attached to the body and to the Angle Bracket on the  $1\frac{1}{2}$ " Pulley 2 by a lock-nutted bolt 3.

Parts required to build the model Tricyclist: 2 of No. 2; 6 of No. 5; 5 of No. 12; 1 of No. 16; 1 of No. 17; 4 of No. 22; 1 of No. 23a; 1 of No. 24; 38 of No. 37; 8 of No. 37a; 8 of No. 38; 2 of No. 48a; 2 of No. 90a; 1 of No. 111c; 1 of No. 125; 2 of No. 126; 2 of No. 126a; 2 of No. 155a; 1 of No. 186; 1 of No. 187; 1 of No. 188; 1 of No. 199; 2 of No. 200. 1 Magic Motor.

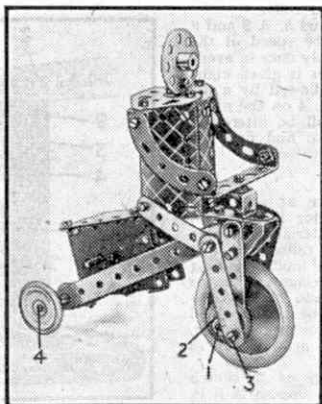

Fig. 2. This amusing Trick Tricyclist is operated by a Magic Motor.

# Meccano Model-Building Competitions

By "Spanner"

## Prizes for Simple Models

We wish to remind model-builders that the "Simplicity" Competition announced in last month's "M.M." remains open for entries until 30th June. There is still time therefore for those who wish to enter the contest and did not see the original announcement, to send in their entries.

Simplicity competitions are always popular since they give fine opportunities for showing how much originality and realism can be achieved in small models, and they appeal to model-builders who have only limited resources of Meccano parts and are prevented at present from adding to their stocks. A further advantage is that Simplicity models lend themselves to simple drawings, a great convenience now that photographs are so hard to obtain.

Competitors should first choose an interesting subject and then set to work and reproduce it in Meccano, using the smallest number of parts that is possible without sacrificing realism. The lower illustration on this page shows typical "Simplicity" models that won prizes in a previous contest. Any number or variety of parts can be used, but the prizes will go to those who make the best use of the smallest number. Every opportunity of simplifying a model should be taken before finally making a drawing or photograph of it for entry in this contest.

Photographs or drawings of models should be sent to "Simplicity Model-building Competition, Meccano Ltd., Binns Road, Liverpool 13" and must be posted in time to reach Liverpool before 30th June. The competitor's age, name and address must be written on the back of each photograph or drawing submitted.

Entries will be divided into two sections. A, for competitors over 12 years of age; B, for competitors under 12 years of age. In each Section prizes of £2/2/-; £1/1/-; and 10/6 respectively, will be awarded for the best entries in order of merit, and there will be a number of consolation awards of 5/- each for other entries of outstanding but lesser merit.

## March "General" Competition Results

The full list of awards in the March "General" Model-building Competition is as follows: 1st Prize, Cheque for £22/2/-: J. H. Smith, Teddington. 2nd, Cheque for £11/1/-: J. Matthews, Fillongley. 3rd,

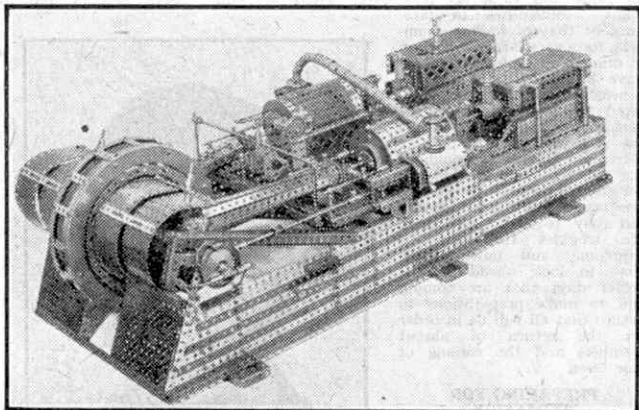

This striking model of a carbon dioxide compressor is remarkable for its many interesting and skilfully-constructed details. It won Second Prize for J. Matthews, Fillongley, in the March "General" Competition.

P.O. 10/6, F. Rowland, Hazel Grove. Consolation Prizes of 5/-: M. Day, Bristol 4; W. Roberts, Sowerby Bridge; E. Rusted, Nuneaton; M. Bleckwen, Feltham; D. Thorne, Liverpool 23; A. Thorburn, Bridport; T. Reedman, Peterborough; R. Goodley, Grantham.

First prize was awarded for a model of a most unusual type built by J. H. Smith, Teddington. It is a reproduction of a self-recording theodolite used for studying and recording air currents at various altitudes. A small balloon is released from the ground and its movement in the air is followed by means of a theodolite of a somewhat similar type to that used by a surveyor, but fitted with clockwork mechanism that drives a recording drum. By means of this mechanism the movements of the instrument's telescope in altitude and azimuth are registered automatically on a chart.

The model designed by Smith is a very neat and practical instrument and was actually used by him for recording the movements of aircraft and the Moon. Unfortunately that of the former was too fast and of the latter too slow for the graphs produced to be of any great interest. It is good to see Meccano users applying their hobby to "off the beaten track" topics of this kind, however, and I congratulate Smith on his ingenuity and skill in constructing his model.

The fine model of a carbon dioxide compressor illustrated on this page forms a very striking contrast to the model just mentioned, and is equally commendable on the score of originality.

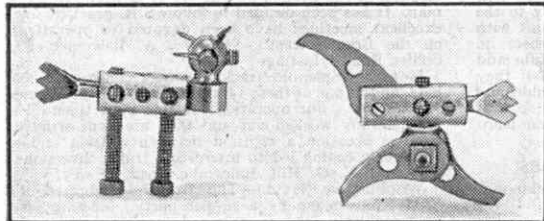

These amusing Meccano creatures are typical examples of suitable entries for "Simplicity" competitions.



# Club and Branch News



## WITH THE SECRETARY

### THE DARK DAYS PAST

We are now at the beginning of a new era for Meccano Clubs and Branches of the H.R.C. For several years meetings have been very difficult, or indeed impossible, owing to blackout conditions and air raids, but these are now over. There are still many difficulties to face, notably that of finding members, for a very large proportion of officials and older members have been absorbed into the Services and are now scattered far and wide over the surface of the Earth, while the impossibility of supplying Meccano Outfits throughout the greater part of the war period has slowed down recruiting. Club rooms too are not easy to find. But these are troubles that can be overcome, and now is the time to look ahead to the better days that are coming and to make preparations to ensure that all will be in order for the return of absent members and the coming of new ones.

### PREPARING FOR EXPANSION

Next Winter indeed should see the beginning of a great revival that will place the Guild and the H.R.C. in an even stronger position than that they held in pre-war days. In established Clubs every effort should be made to overhaul the machinery so that it will be ready for expansion. There will be no difficulty in doing this where things have been kept going throughout the dark days of war, and ways and means will be found to re-establish Clubs that had to close down, as in most of these the Leader or some other official has kept in touch with members by personal visits. There will also be a great demand for new Clubs and Branches. Guild members and those who already belong to the H.R.C. can help splendidly here by setting out with their friends to form Clubs or Branches where no suitable organisation is in existence. Such Clubs and Branches can only expand and be successful if they gain new members, and here I can help by publishing the names and addresses of their proposers, so that enthusiasts living in their neighbourhood can learn what they are doing.

### RECENTLY INCORPORATED BRANCHES

- 474—GIFFNOCK—Mr. W. H. Pickard, 20, Rockmount Avenue, Thornbank, Glasgow.  
 475—HASTINGS—Mr. W. J. Lawrence, 53, Collier Road, Hastings, Sussex.  
 476—RANELAGH—Mr. M. T. Barron, 12, Beeston Grove, Grassendale, Liverpool 19.

## CLUB NOTES

**HORNSEA M.C.**—The practical programme of this Club continues to be carried on with good effect. The Senior Engineers have constructed a telegraph sounnder, the Junior Engineers have made lamp standards, and the Junior Apprentices are busy with Meccano models. Games have been played as usual, both indoors and in the garden. Club roll 45.

Secretary: C. Kemp, 5, Carlton Terrace, Hornsea.

**STAPLEFORD M.C.**—A new form of programme is being followed, and prominence is now being given to nature study. Mr. C. W. Hunt, Leader, and the Treasurer have both given talks and a very interesting museum of specimens is being built up by members. The Library now contains over 150 volumes. Club roll: 8. Secretary: P. R. Dennis, 36, Hickings Lane, Stapleford, Nottingham.

**EDINBURGH HOBBIES M.C.**—Contact with the many members in the Services is fully maintained, and news of them is given in the "E.H.C. News Letter." This also publishes portraits of the members, and recent issues have included a contribution from H. W. Govan, one of the founders of the Club, describing an Indian journey, and articles on soldering by G. H. Shepherd. Leader: C. Morrison, 28, Wellington Street, Edinburgh 7.

**TYNECASTLE M.C.**—Good practical work continues, small ship models, sets of chessmen and a toy zoo being among the many things constructed. Aeroplane models also are being made and one member has made a buttonhole torch. Club roll: 20. Secretary: W. Mation, 21, Hutchison Cottages, Slateford Road, Edinburgh.

## BRANCH NEWS

**HASTINGS**—Interesting meetings have been held in a special room placed at the disposal of the Branch by Mr. W. T. Lawrence, Chairman. It has been decided to follow S.R. practice, and excellent meetings have been devoted to operations on the Branch track. Secretary: A. Lawrence, 53, Collier Road, Hastings.

**HORLEY**—Splendid track meetings continue to be held, and at one of these 14 locomotives and 44 wagons were in use. For operations of this kind timetables are carefully worked out and they are kept strictly. On one occasion a collision between a train and a stationary engine led to interesting traffic diversions. Secretary: K. G. Hill, Balcombe Road, Horley.

**WOODLANDS (HULL)**—The Branch celebrated its First Anniversary by a supper party. Meetings are held regularly, and it is hoped soon to arrange an open air programme. A magazine is now being published weekly. Secretary: D. Kennington, 53, Scalby Grove, Derringham Hull.



T. C. Hindson is Secretary of the Durham M.C., Leader, Mr. G. Hindson. This Club was affiliated in February of this year and has made an excellent start. Meetings are held twice weekly, and in addition to Model-building members have enjoyed interesting Lantern Lectures, a "Locomotive and Animal" Quiz, chemical experiments and carpentry.



# What is Gauge 0?

**M**OST of us have become so familiar with the terms Gauge 0 or Gauge 00 that we are apt to use them without appreciating fully just what they mean.

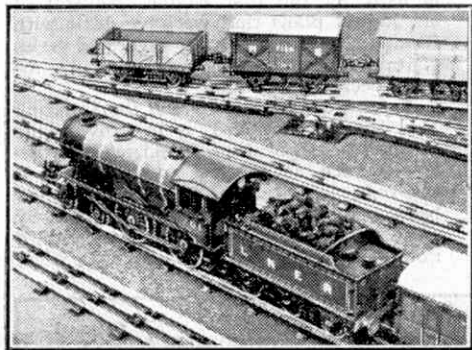

A typical Hornby E220 Special Locomotive, representing the L.N.E.R. Locomotive No. 201 "The Bramham Moor."

We know of course that Hornby Trains belong to Gauge 0 and that Hornby-Dublo Trains belong to Gauge 00.

The word gauge as applied to railway tracks means the width of the track as measured from inside to inside of the rails. The standard gauge in Great Britain is 4 ft. 8½ in.; in Northern Ireland and Eire it is 5 ft. 3 in.; other gauges, both wider and narrower, are used in various parts of the world. In the Hornby Railway System the width between the running rails is 1½ in., which is the standard for Gauge 0 trains. Comparing the real and the miniature rail gauge therefore we find that Gauge 0 is approximately  $\frac{1}{16}$ th full size.

This does not mean however that every Gauge 0 component is  $\frac{1}{16}$ th of the size of the corresponding real thing. It is not, for various reasons. Rails and wheels, for instance, are coarser than they would be if made to exact scale, because of the comparative roughness of the miniature track, which may be anything but a "permanent way," and of the fact that model wheels are not spring borne and have to traverse more severe curves at comparatively

higher speeds than do the real ones.

The question of space, which every model railway engineer is up against, necessitates these comparatively severe curves. This means that bogie vehicles have to be cut down in length from what they should be to scale; and the overhang of vehicles generally on curves means that a greater space must be left between the ends of the vehicles when coupled up than would be the case if everything could be to scale. Thus the term "scale model" must not be read in its absolute literal sense when applied to working model railway material of the ordinary kind.

The standard radius for Hornby tinsplate curves is 2 ft., measured from the centre of the circle to the inside edge of the inner rail. The Hornby System includes 1 ft. radius curves and points, but the locomotives and rolling stock intended for use on them are of the smaller four-wheeled types. In consequence they have quite a reasonable appearance, and satisfactory running and quite good fun can be obtained. Bogie engines and stock have never been included in the Hornby Series for use on 1 ft. radius rails; for them the 2 ft. radius rails are essential.

Still better running is afforded by the use of Hornby Steel Track. The curves and points on this track have a radius of 3 ft. 2 in. measured to the inside edge of the outer running rail.

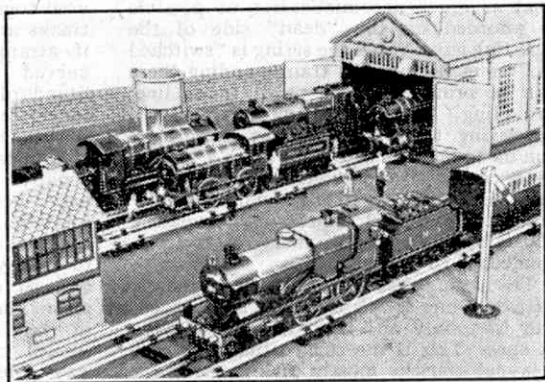

A Hornby L.M.S. Compound 4-4-0 passing a realistic group of locomotives standing in the Engine Shed sidings.

# Controlling Dublo Electric Trains

FIRST of all it is imperative that the layout should be "wired up" correctly; that is the electrical connections between the power supply and the track via the control apparatus should be properly made. It is easy enough to connect up a simple single track layout, but, judging from the correspondence received at the Editorial Office, schemes often go wrong because Dublo enthusiasts attempt to elaborate an arrangement for the material they have in hand.

An item concerning which there has been a certain amount of misunderstanding is the Isolating Rail. This consists of a short length of track, the centre rail of which is divided into two insulated sections, connected to a terminal fitting that projects from the track base. Primarily this rail is intended to be used in connection with the Isolating Switch, or with a simple on-off switch of any kind, for the purpose of isolating electrically a length of track from the remainder of the system. This makes it possible to switch out, and thus render "dead," a buffer stop siding, so that an engine or complete train can stand there while another train is travelling on the main line. In such a case the Isolating Rail is included in the siding conveniently near to the points where the main line is joined, so that as much accommodation as possible is afforded on the "dead" side of the isolating gap. When the siding is "switched in," or made live, the train standing there can be brought out on to the main line, providing that the train previously occupying the main line has itself been run on to another siding, or on to a section that can itself be made dead. A loop line being joined to the main line by points at each end requires two Isolating Rails; but only one of them needs to be connected to a switch.

The arrangements just described assume that only one source of power is provided, and that only one train is on the move at once. This is the usual situation where a layout consists mostly of a single track main line, but with various loops and sidings. Two or more locomotives can

be in use on the track, but only one can be run and controlled at one time, any others standing respectively in sidings, shed roads or loop lines that are "switched out" from the main track while the latter is used by the first engine. Several of the layout plans that we have dealt with from time to time, giving suggested series of operations involving different trains, have been of this kind.

Another purpose for which the Isolating Rail has been applied, is to provide the means of separating, electrically, two tracks such as the up and down of a two-road layout, the tracks themselves being connected for running purposes by means of two sets of points. The standard Points have been designed so that when

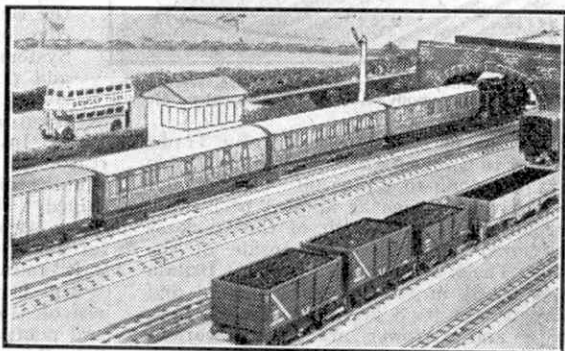

Two main line tracks and a system of sidings are shown in this illustration of part of a Hornby-Dublo layout.

used together to form a crossover the two tracks are the correct distance apart, and if arranged as a double line oval the curved sections will be symmetrical. Standard radius curves are used for the inner track and the special Large Radius Curved Rails for the outer one. In such circumstances electrical separation is usually secured by placing a strip of paper between the centre rail clips at the joint in the connecting line. On permanent layouts it is sometimes the practice to remove the centre rail clips entirely and so obtain the desired effect. This means, however, that should an alteration in the layout be made, the points are spoiled for use elsewhere in the ordinary way unless they can be restored by the owner.

By whichever method this electrical

separation is secured, a train can be run on each track at the same time, and both will be perfectly controlled independently of the other, provided that we have a Controller connected to each track, one Controller being connected to one pair

long as the conditions regarding a separate source of current are met.

Only where a single source of current of sufficient capacity, either transformer or accumulator is in use, is the complication met of additional breaks in the running rail as well as the centre rail. No attempt should be made to use power units of other makes instead of the Hornby-Dublo Transformer No. 2, where an output is required greater than that for one train; and if accumulators are in use a separate one for each Controller section is necessary.

As the diagram shows, all the normal movements of trains can be provided for. We can have an express running on one of the main tracks while a stopping train in the opposite direction calls at stations on the other. At the same time an engine or train can be working in the branch section. This latter section can be developed into a system of sidings where shunting and marshalling can proceed more or less continuously. Alternatively, the branch can lead to a terminal station where departure or arrival operations require to be carried on independently of main line "happenings." It is advisable for each track of the terminal or yard to have an Isolating Rail so that it can be made live or dead as required.

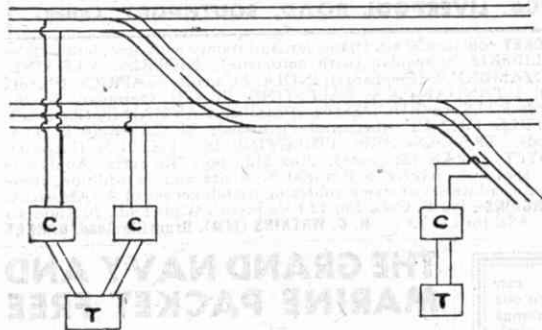
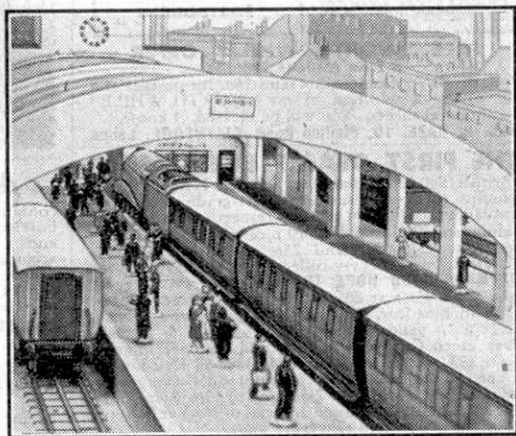

Diagram of the wiring of three independent track sections of a Hornby-Dublo layout where a separate source of current is available for each track.

of output terminals on the Dublo Transformer No. 2, and the other Controller being connected to the other pair. Each train can be reversed, started, stopped and so on from its Controller without in any way interfering with the movements of the other, since each draws its current from a separate source, although only one Transformer is used.

The independence of the sources of current to the Controllers is the important point here.

A further development of the independent control scheme is shown in the diagram on this page. This shows the up and down main lines as referred to previously, and the wiring between them and their respective Controllers and the separate output terminals of the Dublo Transformer No. 2. In addition there is a further set of Points which may lead to a system of sidings or to a separate branch line or section of the railway where movements independent of the main line are required. Here again a separate source of current is necessary, and this is provided for in the diagram by means of another Transformer together with another Controller for governing the movements of the shunting engine. Once more a single break in the continuity of the centre rail is all that is required, so



A terminal station layout in Hornby-Dublo of the type where control of the station tracks independent of the main line is desirable.

## BARGAIN DISCOUNT APPROVALS

We offer a fine range of picked Modern and New Issues on approval from 1d.—6d. each. (Better selections also available). Generous discount and prompt attention. Br. Colonials or Mixed selections post free on request. (We do not send again unless requested). Current and Obsolete mint G.VI and Coronations in stock. "Wants" lists welcomed for singles, but no single-country sheets available.

Postal Business Only

**THE BIRKDALE STAMP CO. (P.T.S.)**  
104, LIVERPOOL ROAD, SOUTHPORT, Lancs.

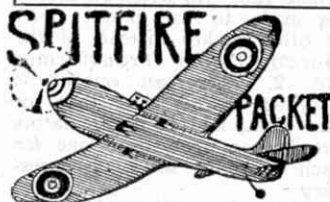

PACKET contains 30 air, triangular, and stamps with aeroplanes, etc.—2 LIBERIA triangular (with aeroplane); NIGERIA; UKRAINE; MOZAMBIQUE (Elephants); INDIA; 2 Canada; S. AFRICA (Pictorial); 2 TANGANYIKA; PALESTINE; BRAZIL (aeroplane design, etc.); 5 U.S.A.; RHODESIA; Australia; CAYMAN IS. (Pictorial); 3 FREE FRENCH (beautiful Pictorials); MOZAMBIQUE (Pictorial); TRAVANCORE; PHILIPPINE IS.; CEYLON (Pictorial); EGYPT; JAPAN (Emperor). Price 5½d., post 2½d. extra. Applicants for approvals receive 6 Pictorial S. Africa and in addition, those sending addresses of stamp collecting friends get set of 4 JAMAICA. **BARGAINS**—100 B. Cols. 2/6; 12 Free French (Cols.) 9d.; 20 Rhodesia 1/6. ASK for LISTS 1d. H. C. WATKINS (MM), Granville Road, BARNET

### 1d. UPWARDS

Every General Collector who can recognise good value should be on our approval service. Not only are our stamps reasonably priced, but also we offer a worth while discount, and other special advantages to regular customers. You need only send a postcard for trial selection. We pay postage.

**CAPT. M. CAMPBELL & CO. (Dept. MM)**  
15, North West House, West St., Brighton

## THE GRAND NAVY AND MARINE PACKET FREE



The finest packet we have ever offered due only to a lucky purchase of fine stamps. IT CANNOT BE REPEATED. It includes the fine illustrated South Africa emission, also ICELAND (Fish), Australia (Sailor), fine temporary over-printed issues old Bohemia, WALLIS Canada, K.G.VI, NEW ZEALAND (Admiral) and many others space will not permit us to describe. DON'T FORGET supplies are limited, so SEND IMMEDIATELY 3d. towards postage and packing and request our special approvals.

**LISBURN & TOWNSEND LTD. (M)**  
41, Norton Street, LIVERPOOL 3



### DON'T MISS THIS!

**FREE. Globe-Trotter's Record Offer.** 1/6 Australia Air Mail (cat. 10d.); Ecuador 1908 Railway Stamp (cat. 4d.); Australia 1932 6d. Kookaburra stamp. Add these attractive stamps to your collection by writing NOW enclosing 3d. stamp and asking for Approval Selection.

Globe-Trotter, 70, West Ave., B'ham 20

## APPROVAL BOOKS

containing low and medium priced Colonial and Foreign stamps still sent to applicants. Good discount and a list of 90 FREE GIFTS varying in value according to money sent for purchases. These gifts can be chosen by you from this list which contains King George VI, Jubilees, Free French, ALL the Coronation Sets Mint, etc. 3d. stamp please.

C. A. RUSH, 38, Queen's Avenue, Whetstone, London N 20

## KING GEORGE VI

A fine packet of unused British Colonials of the present reign from the Cayman Islands, Cyprus, Grenada, Dominica, Malta, Kenya and Uganda, also Southern Rhodesia Jubilee sent free to all applicants for approvals enclosing 2½d. postage.

**R. D. HARRISON, ROYDON, WARE**



**FREE to all STAMP COLLECTORS SENDING 2½d. POSTAGE NEW COMMEMORATIVE from ZANZIBAR**

**G. P. KEEF WILLINGDON EASTBOURNE**

### FREE "WORTH WHILE" OFFER

8 Fine Midget Stamps

Free to all applicants who send 2½d. for postage and ask to see a selection of my "WORTH WHILE" approval sheets. You will be pleased. I know.

JOS. H. GAZE, 10, Pimlico Road, CLITHEROE, Lancs.

## THE FIRST STAMP EVER ISSUED

(British 1840 Penny Black) for P.O. 7/9! It is guaranteed genuine in every respect. (Better-grade copies also available at 10/6, 15/6 and 20/- respectively). Its companion stamp (1840 2d. blue) nice used at 11/9 (better grade at 15/6, 20/- and 25/- respectively). Other "Classics" which every collector should have are the **CAPE OF GOOD HOPE TRIANGULARS**; we offer 1d. rose (cat. 45/-) at 20/-; 1d. brown-red (cat. 57/6) at 22/6; 4d. blue (cat. 20/-) at 10/-; 6d. pale lilac (cat. 45/-) at 20/-; 1/- yellow-green (cat. 90/-) at 32/6; 1/- deep dark green (cat. 90/-) at 37/6; and 1/- emerald-green (cat. £7) at 52/6; also **VICTORIA 1850-55 Half-Length Queen 1d.** (cat. to 70/-) at 10/- (fair) to 25/- (very fine); and 3d. (cat. to 50/-) at 7/6 (fair) to 17/6 (very fine); 1854-55 Queen on Throne 2d. (cat. to 25/-) at 5/- (fair) to 12/6 (very fine).

**SUPERB APPROVALS** (general, or by countries for really serious collectors and specialists) against approved English references or a deposit.

Current price list 1d. post free.

**NORRIS & CO. (Dept. M), SOMERCOTES, DERBY**

# Stamp Collecting

## On the Back of Stamps

By Roy G. Neal

HAVE you ever studied the back of your stamps? The backs of some of them are more interesting than the front. For instance, on the back of the Portuguese issue of 1895, commemorating the 200th anniversary of the birth of St. Anthony of Padua, is a Latin prayer on the "Solemnity of the Tongue." The rear of the May 1919 issue of Fiume bears the inscription "Posta di Fiume," while the higher values of the 1920 issue commemorating the capture of Fiume by D'Annunzio's "Legionaries" have the "Snake and Stars" badge of D'Annunzio's followers on the back.

Some Swedish stamps have had a post-horn depicted on the back. Such cases were probably meant to be substitutes for watermarks, any forger having a double job to do before producing an efficient fake. In New Zealand, experiments were made in 1925 with different types of paper, so that in an emergency stamps usually printed on paper watermarked with "N.Z." and the star were issued with the same pattern faintly lithographed on the back.

Shortage of paper has been the cause of many other freak stamps. It caused the first issue of Latvian stamps to be printed on the backs of German war maps, and the 1920 issues of the same country were printed on the backs of Bolshevik bank notes, but the stamps issued on wall-paper and jam-jar labels were only an attempt to exploit the popularity of the freak stamps, and were not official issues. In Lithuania the same trouble of paper shortage caused paper normally used during the war for ration tickets to be used for printing stamps. During a revolution in Oaxaca, Mexico, postal forms were used.

Then there is the strange case of a stamp starting as a railway stamp, then becoming fiscal, and finally a postage stamp! Between 1910 and 1912 Nicaragua had no funds available to pay for the printing of a new issue in England or U.S.A. So fiscal stamps were surcharged and used as postage stamps. But soon the supply of fiscals ran out. The authorities then turned to the railway stamps, but these were already



surcharged for use as fiscals. This difficulty was overcome by adding another surcharge on the back.

Other interesting stamp oddities were those used or money. Between 1915 and 1917 some Russian stamps were printed on card, with an inscription on the back. They were intended for use as small change, although a few were used as stamps, and the design was the same as that of postage stamps of the same period. France and some other countries also used stamps for coinage during the Great War, but in this case the stamps were contained in cases with transparent sides. Rhodesia tried stamp coinage, the stamps being stuck on cards bearing the warrant of local authorities that they should be used as money.

Yet another freak issue was the Prussian issue of 1886. The stamps were printed on the gummed side of thin, transparent paper, so that their design showed through the paper when they were stuck down. This prevented stamps from being used twice. Many Spanish stamps have a serial number printed on the back.

There have been many attempts to use stamps for advertising. In 1887 Mr. J. Barratt offered a large sum of money to have the words "Pearl's Soap" printed on the backs of the 1d. and 1d. stamps of Great Britain. Some experiments were made with

the words in mauve, orange, or blue, but the scheme was never carried out, for the P.O. suppressed it. Incidentally some of the 1d. and 2d. values of the same issues were printed on the gummed side, and a few of the 1d. value even on both sides. There were no more attempts



at advertising in British stamps, although in British stamp booklets there have been pieces of perforated paper, the same size as the stamps, with advertisements on them. Many of the New Zealand Queen Victoria portrait issue of 1882-97, issued in 1893, had advertisements printed on the back.

Some years ago Italy issued certain postage stamps with advertisements, not on the back, but beneath the ordinary design on the front, unseparated by perforation. Therefore it could be said that it was a part of the stamp itself. Two examples I have seen are an advertisement for the Singer sewing machine attached to the 50 c. of the 1906 issue, and an advertisement for "CAMPARI" liquor on the 15 c. of the same issue; in both cases the advertisements were illustrated. But the idea was soon dropped for manufacturers objected to using stamps advertising the goods of rival firms. Belgium also experimented with the same idea, but with the advertisement separated from the stamp by perforation.

Perhaps if you examine the backs of your stamps carefully, you may come across a freak such as those dealt with in this article.

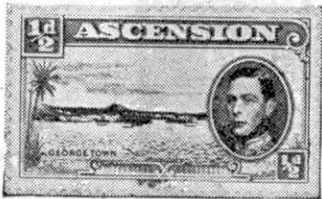

**ASCENSION—FREE**

You simply must get this lovely stamp for your collection, and you can get it from us **ABSOLUTELY FREE**. It comes from the lonely island of **ASCENSION** and shows a view of Georgetown from the sea. **ASCENSION** is a little island in the South Atlantic, with an area of only 38 square miles and only 190 inhabitants. If you would like your collection to be more interesting and more valuable, you must have one of these stamps. Send to the Windsor Stamp Co. and ask for the **ASCENSION** packet and it will be sent to you **ABSOLUTELY FREE**. You must ask to see an approval selection and price list, and you must enclose 3d. in stamps for postage. Write name and full address very clearly.

**WINDSOR STAMP CO. (Dept. M), UCKFIELD, Sussex**

**MAJOR POWERS STAMPS**

We will send **FREE** 8 attractive stamps from the U.S.A., U.S.S.R., Gt. Britain and China to all applicants for our famous approval sheets enclosing 3d. to cover postage.

Apply—

**ERRINGTON & MARTIN**  
Dept. 414, South Hackney, London E.9**25 STAMPS**

includes **COOKS IS., PAQUA, ADEN, Seychelles, Mozambique, TRINIDAD, etc.** To applicants for my approvals of cheap sets and single stamps. **WITHOUT** approvals 9d.

**S. H. Fleming, Newhaven, Glyn Ave., Colwyn Bay, N. Wales**

Write to-day for British Colonial Approvals 1d.—6d. single items, also Coronations and short mint sets. Postage 2½d. Purcell, 22, Green Lane, Amersham, Bucks.

**DISCOUNT APPROVALS**

As advertised for years and sent **REGULARLY** to hundreds of readers of this magazine.

A postcard will bring a selection, and full details of our **COMPLETE** service.

**THE GEM STAMP CO.**

**1729, London Road, Leigh-on-Sea, Essex**

**FREE—STAMPS CATALOGUED 5/-**  
to applicants for 3d. approvals.

**COX, 17, STONELEIGH PARK ROAD, EWELL**

BERMUDA. 1920 Tercentenary 1d. mint cat. 3/- 1/6  
EGYPT. 1945 10+10m. Khedive 1smail mint... 1/-  
FIJI. K.G.VI 1/5 mint obsolete and scarce... 2/-  
HONG KONG. 1941 Cent. 2c. mint... 6d.  
HONG KONG. 1941 Cent. 5c. used... 1/-  
NEW ZEALAND. 1944 10d. on 1½d. Cent.  
obsolete superb used... 1/3  
NIGERIA. K.G.VI 2½d. orange mint  
obsolete and scarce... 8d.  
Monthly Bulletin 1/- per annum. (Postal business only).  
**IVAN GRAY & CO., 76, University Ave., BELFAST**

For other Stamp Advertisements see also pages 210 and viii.



**Phillip J. Dyke (P.T.S.), 35, Buckingham Ave., London S.W.20**

**"MERCURY MAJOR"**

● Serious Medium Collectors will be eager to see this fine new series of British Colonial Approvals, ranging from Q.V. "Classics" to K.G.VI Pictorials. The usual fine "Mercury" quality! ● Please send 3d. for postage and list, and ask for "Mercury Major" Approvals, stating your needs.

**STAMPS catalogued 6/6, 2/6, penny each! Approval, postage. J. Baguley, 22, Lawnswood, Romford.**

**Low. INDIA S.G. SIMPLIFIED Cat. Numbers.**  
Values of India Mint marked \*. Postage Please.

1d. ea. 9, 24, 26, 28, 36\*, 36, 38, 39, 48, 49, 50, 51, 65, 66, 67, 68, 69, 70, 71, 76, 79, 80, 82, 83, 85, 107, 108, 109, 110, 121, 122, 123, 124, 141, 142, 143, 019, 020, 021, 022, 023, 029, 030, 031, 032, 033, 034, 043\*, 043, 044, 045, 046, 047, 048, 050, 070, 071, 072, 073, 076, 077, 078, 083\*, 083, 084, 085, 086. 2d. ea. 10, 65, 75, 86, 87, 112, 116, 117, 126, 127, 132, 144, 146, 147, 148, 149, 152, 013, 035, 048, 052, 074, 084\*, 084A, 085\*, 087, 087A, 090, 091. 3d. ea. 29, 53, 81, 103, 111A, 128, 130, 135, 143A, 145, 014, 024, 025, 028, 037, 048A, 054, 067, 073\*, 075, 079, 082\*, 082, 086\*, 088. 4d. ea. 30, 37, 40, 47\*, 52, 54, 72, 78, 94, 102, 113, 114, 115, 131, 132, 150, 151, 06, 018\*, 018, 026, 036, 053, 088\*. 6d. ea. 18, 41, 74, 84, 88, 93, 133, 136, 03, 04, 027, 060, 066, 067\*, 068, 069. 9d. ea. 12, 19, 32, 43, 56, 58, 101, 129, 133, 01, 07, 051, 066\*, 069\*, 080, 089. 1/- ea. 27, 35, 95, 111, 118, 016, 038. 1/3 ea. 13, 25\*, 25, 97, 104, 055.

Please send me your "Wants" List for other India items. India Pkts., 50 diff., 2/6; 100 diff., 5/-; 125 diff., 10/-.  
**F. Harlow, B.P.A., 133, Bradbourne Vale, Sevenoaks, Kent**  
\*Phone: Sevenoaks 2742 Bankers: Barclays Ltd.

**HALF PRICE APPROVALS**

We are offering until further notice special books of **BRITISH COLONIALS** incl. **CORONATIONS** and **K.G.VI** issues, also **EUROPEAN** and other **FOREIGN**

**at 50% DISCOUNT**

Minimum purchase, 10/- worth for 5/- net.

Send stamp for trial selection.

**SAUNDERS & CO., 51, Draycott Avenue, HARROW**

**3 Unused FALKLANDS FREE!**

This attractive set will be presented entirely free to serious approval applicants. Only one gift to each applicant. Write to-day, and enclose 2½d. stamp. *Postal Business only.*

20 diff. New Zealand 9d. 15 Iraq 9d.

**W. LE MERCIER, 58, LUMSDEN AVE., SOUTHAMPTON**

# Stamp Gossip

## and Notes on New Issues.

By F. E. Metcalfe

PERHAPS the most interesting stamp to be illustrated this month is one of a set of two issued by Peru, of all countries, to commemorate the centenary of the electric telegraph. The portrait on the stamps is that of Samuel Morse, well known by repute to "M.M." readers. This American inventor was born as long ago as 1791, but it was not until 1829 that he evolved the idea of employing electro-magnetism in telegraphy, and six more years were needed before an instrument could be exhibited

which would work satisfactorily.

In 1843 the U.S. Congress provided funds for the construction of an experimental telegraph-line between Washington and Baltimore. This was a success, and gradually the Morse instrument came into general use in both Europe and America. The U.S.A. of course also issued a stamp in connection with this centenary, in 1944. It will be remembered that we mentioned the stamp at the time, but we



had no space then to illustrate it. As many readers will not have seen a copy even yet, we are showing it this month.

Another of our illustrations shows an interesting stamp from Yugoslavia, issued no doubt by the Tito government. There are about seven values in this set and the Russian influence is quite evident, as most of the designs have to do with Russian cities, etc. The stamps have been printed in photogravure. This process is now exceedingly popular for the production of stamps, for not only is it relatively inexpensive compared with line engraving, but also it lends itself to rapid output, which suits countries that like a new set every week. Most European countries are in that category. France and Germany lead, with Russia a good third.

Recently we had an opportunity of perusing a copy of the latest Yvert stamp catalogue. In normal times this was the most widely used catalogue in the world, and for general purposes probably the best. Always right up to date, it already lists all the stamps issued during the war by all countries, friends and foes, and if ever all these stamps are imported into this country collectors will need volumes, not albums, to keep them in.

Speaking of war stamps, we came across a rather interesting specimen from Germany the other day, interesting for the change that had taken place in the designation of that country. German stamps used to bear the inscription "Deutsches Reich," but



it is claimed, for use in the liberated parts of Czechoslovakia. All designs show a war hero, such as a fighter pilot, parachutist, etc. The stamps are attractive enough, and no doubt they are needed, but there is one small point that needs clearing up. Last year the same authorities issued a number of stamps, in the form of a miniature sheet. Stamps similar to these were to be placed on sale as soon as Czechoslovakia was freed. What about it? Supplies of the new stamps, including air stamps, are said to have been sent to Czechoslovakia. Maybe.

No one can deny the beauty of many stamps issued from time to time by various foreign countries, but quite frankly British collectors will be well

advised to stick to their own colonial issues, that is if they are spending more on stamps than they are prepared to throw away on a hobby.

It is not claimed that our colonial pictorials are as artistic as some of these foreign issues. As a matter of fact, all too often the design is somewhat crude and the colours are ill matched; Northern Rhodesia is a case in point. On the other hand, the stamps of say Malta and Falkland Islands are as beautiful as one has a right to expect, and moreover these stamps are as likely to maintain their value as any stamps in the world.

Again it is repeated, for safety in stamp values stick to British Colonials. The other day we were speaking to an American major who has substantial stamp interests in the U.S.A. He gave it as his opinion that after the war, when American collectors have got over the novelty of seeing these European war stamps, they will go after our "Colonials" in a much bigger way than they are doing even now. Such an extra demand is bound to keep values up. Of course he was referring principally to stamps of the present reign. All this is to the good. One may not be collecting for profit, nor has one a right to expect a hobby to show one; but the average collector spends a good deal more than he wishes to throw away, so some security is quite rightly sought.

Last month our tip got crowded out, but a nice little item that can be recommended perhaps is the 4d. all green coil stamp of South Africa. This must be collected in pairs of course, as one stamp is in English and the other in Afrikaans. Actually this stamp has been out since 1943 and there is good reason to believe that it is already obsolete.

apparently in 1943 this was changed to "Grossdeutsches Reich." Alas for the "Gross." Little remains of that now.

The first of May saw the appearance in London of a new set of eight stamps issued, or so



**How Files are Made—(Continued from page 199)**

that would help them to collect on another. A skilled hardener can harden as many as six or seven hundred files a day.

The files when examined and hand straightened, since the cooling may have warped them again, are now sand-blasted or scoured to rid them of scale and the preparation put on the teeth to protect them. An apparatus is used which forces against the file surface a jet of steam and sand at a pressure of 80 lb. per sq. inch. This done, the files are rinsed in clean lime water and coated with a solution or emulsion of oil and water to keep them from rusting. After this, another vital operation must be carried out. This is tempering the tangs. It is a softening operation, but not so much so as the annealing referred to earlier, and it is designed to prevent the tangs from cracking at the shoulder when the handle is fitted. Some small works use a lead bath for this purpose also, but mostly a radiant heat, surface-combustion furnace is used because it is cheap in gas consumption.

After they have grown cold, the files are immersed in a bath of oil and water, and dried on stoves. The water evaporates and leaves the oil behind in the form of a thin film, which prevents rust. The next stages are rigorous testing and inspection, most essential at this stage. The file is first inspected to see if it is straight. Then it is tapped on a steel block to see if it sounds cracked. A skilled examiner can by ear alone detect a tiny crack that to a novice would not be audible. Lastly, the file teeth are rubbed vigorously with a piece of steel of known composition and hardness, and if there is any lack of 'bite', or any soft spots, are discovered, the file is scrapped. The skill of the inspector again enables his sensitive touch to detect in an instant a soft spot that the untrained would never perceive.

Lastly, the files are bundled together, wrapped in casing paper or placed in cardboard boxes, and if for export, packed in tin-lined cases.

It should be noted that a certain number of files are made by etching the teeth with an etching tool, while rasps, of course, though made in most respects similarly to files, have their teeth formed on a different type of machine and in a different manner, a punching tool striking a blow that forces up the metal in a kind of triangular flap to form the teeth.

### COMPETITION RESULTS

#### HOME

**January "Cover Voting" Contest.**—1st Prize: A. Warren, Highbridge; 2nd Prize: A. M. Stainer, Twickenham; 3rd Prize: R. Chilton, Chalfont St. Giles. Consolation Prizes: B. N. Thomas, Chester; A. B. Widgey, Norwich; J. A. Patterson, Sevenoaks; A. Maddison, Manchester; B. W. Grimshaw, Oldham.

**January "Railway Quiz" Contest.**—1st Prize: T. Oldham, Bulwell; 2nd Prize: N. Killgren, Cottingham; 3rd Prize: R. Houseman, Stockport. Consolation Prizes: I. D. Hogg, Edinburgh; A. J. Pickworth, Barnard Castle; G. F. A. Gilbert, Brookmans Park; F. Mills, Kearsley.

**January "Photographic" Contest.**—1st Prizes, Section A: A. W. Bull, Beeston; Section B: P. L. Nott, London. 2nd Prizes, Section A: E. M. Jordan, Ryde; Section B: M. S. Berger, Cheltenham. Consolation Prizes: R. Atkins, Eccles; J. M. Doble, Liverpool; I. D. Ford-Young, Crondall; F. Coleman, Saltcoats.

**February "Locomotive" Contest.**—1st Prize: D. Heneage, Maiden Erleigh; 2nd Prize: D. J. Herd, Morden; 3rd Prize: F. Mills, Kearsley.

**February "Missing Words" Contest.**—1st Prize: M. J. Badrock, Durrington; 2nd Prize: A. E. Sparrow, Hayes; 3rd Prize: P. R. Wickham, Leicester. Consolation Prizes: J. S. Wreford, Preston; K. Bagnall, Exeter; A. F. Betts, Leighton; W. Bishop, Birmingham.

**March "Locomotive" Contest.**—1st Prize: D. Barr, Holmes Chapel; 2nd Prize: R. Munday, Heston; 3rd Prize: J. L. Clark, Hull. Consolation Prizes: R. D. John, St. Annes-on-Sea; P. Stevens, London; C. E.

**PUSSY AND HER PINT**

By J. DENTON ROBINSON

The remarkable stained glass window seen in the illustration on this page, is in the quaint old inn called "The Squinting Cat," near Harrogate, Yorkshire. The name is surely one of the most unusual for a public house to be found in any part of the country.

It is reputed that the inn got its strange name many years ago, when it was a small farm. Labourers who used to pass the place saw an old woman always peeping through the curtains, much to their disgust. They would say "There's the old squinting cat again," and so now we see Pussy, with the squint and also a nice pint, which appears to be larger than the "reputed pint," sitting in the window as of old. The floral design gives the impression that the cat is wearing a flower bedecked hat.



The stained glass window of "The Squinting Cat," the story of which is told on this page. Photograph by J. Denton Robinson.

Wrayford; Bovey Tracey; N. Killgren, Cottingham.

**March "Go As You Please" Contest.**—1st Prize: R. Parkerson, Bungay; 2nd Prize: A. Permentiers, Edgware; 3rd Prize: J. Ferris, Edinburgh. Consolation Prizes: B. Smith, Cheltenham; L. Yarwood, Gourcock; J. Duffly, London; S. A. Hunter, Annfield Plain, D. Elphick, London; P. Boardman, Blackpool; T. Moody, Bristol.

**March "Photographic" Contest.**—1st Prizes, Section A: T. Jones, Omlwyn; Section B: R. W. Hennessey, Rustington. 2nd Prizes, Section A: W. E. Silvester, Bromley; Section B: D. Townsend, Long Eaton. Consolation Prizes: F. J. Reynolds, Sidcup; P. Milne, Whyteleafe; R. Smith, Cranleigh.

**OVERSEAS**

**June "Code Words" Contest.**—1st Prize: C. Brackenridge, Perth, W.A.; 2nd Prize: G. Stokes, Port Elizabeth; 3rd Prize: G. Isaacs, Johannesburg. Consolation Prize: R. A. F. Smith, Pretoria.

**June "Railway Quiz" Contest.**—1st Prize: J. A. Markham, Windsor, Canada; 2nd Prize: F. J. Harrison, Bulawayo; 3rd Prize: D. E. Mayers, Bombay.

**June "Photographic" Contest.**—1st Prizes, Section A: N. Tasker, East Maivern, S.E.S.; Section B: G. Davies, Cape Town. 2nd Prizes, Section A: H. Lewis, Johannesburg; Section B: E. Barrington, Transvaal.



# Competitions! Open To All Readers

## June Crossword Puzzle

### CLUES ACROSS

1. Place of worship
5. Compliance
10. Mineral
11. Seaman
13. Cast
14. Men
16. Attach
19. Narrate
21. Foremost
22. Blind pirate
24. Strip of leather
25. Dried leaves of plant
26. For punishment
27. Before
28. Lamb
30. Animal
31. Relatives
33. Wrap up
35. Order
36. Quantity
39. Long and hanging
41. Bone
43. Skin
45. Mistake
46. Peasants
47. Deer
48. Correct
51. Single
52. Rain and snow
54. Holy person. 56. Fear. 58. Prefix. 59. Consume. 60. Fast. 61. Flow.

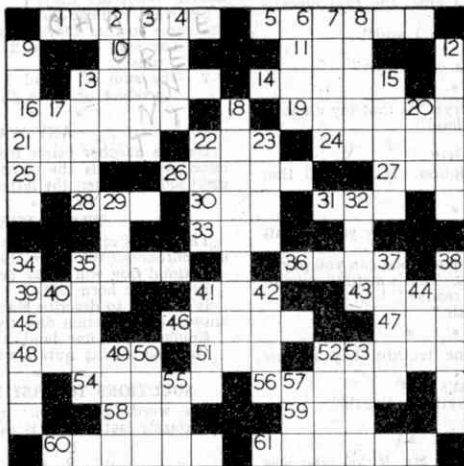

### CLUES DOWN

2. Animals
3. Publish
4. Place on loan
6. Heavenly body
7. Auctions
8. Put up
9. Cunning
12. Guard
13. Fish
15. Makes warning sound
17. Indian coin
18. Feeling
20. Hill
22. Chime
23. Insect
29. Wicked
32. Measure
34. Thieves
35. Sets alight
37. Paid for use
38. Heavy mallet
40. Weapon
41. Basis
42. Brought up
44. Deer
49. Part of neck
50. Dreadful
52. Burn
53. Tardy
55. Head salute
57. Steep

This month's crossword puzzle, submitted by our reader F. Lintin, Mirfield, will be found to follow the lines of the previous ones we have set on this page. Every effort has been made to provide a fair and interesting puzzle, without any traps in the form of alternative solutions. The clues are all perfectly straightforward, and every word used can be found in Chambers' or any other standard dictionary.

As usual, there are two sections in the competition,

for Home and Overseas readers respectively, and in each prizes of 21/-, 15/- and 10/6 will be awarded for the best solutions. If necessary judges will take neatness and novelty into consideration. Entries should be addressed "June Crossword, Meccano Magazine, Binns Road, Liverpool 13." Closing dates: Home Section, 31st July; Overseas Section, 31st January, 1946. Do not cut out the diagram on this page. Make a copy of it for your entry.

## A "Locomotive Pie"

Readers of the "M.M." are keenly interested in the names and numbers of the locomotives of the four British railway companies. Practically all of them study closely the various classes, and are conversant with the numbering systems. Here is a contest in which they can put their knowledge to good use.

Below we give a series of letters and figures, and the competitors are asked to build up from these the numbers and names of as many locomotives of the British railway companies as possible. It is not necessary to use all the letters and figures in any one name and number, but each can be used as often as it appears in the list.

A A B C D E F G H I J K L N N  
O O P P R R S S T U Y  
0 0 1 1 1 2 4 5 5 6 6 7 8 8 9

An example or two will make the position clear. L.M.S. No. 6100 "Royal Scot" can be included in the solution, for no figure or letter in it appears more often than in the list. On the other hand the Southern locomotive No. 858 "Lord Duncan" cannot be included, for the name includes two "D's" and there is only one available for use.

Readers should put together as many names and numbers of locomotives as they can, and should then send in their entry to "June Locomotive Pie Contest, Meccano Magazine, Binns Road, Liverpool 13." There

will be Home and Overseas Sections, in each of which prizes of 21/-, 15/- and 10/6, respectively, together with consolation prizes, will be awarded for the entries judged to be the best. In the event of a tie for any prize neatness and novelty will be considered. Competitors must remember to put their names, full postal address, and age on the back of each sheet submitted. The closing dates are as follows: Home Section, 31st July. Overseas Section: 31st January 1946.

## June Photographic Contest

This month's photographic contest is the 6th of our 1945 series, and in it, as usual, prizes are offered for the best photographs of any kind submitted. There are two conditions—1, that the photographs must have been taken by the competitor, and 2, that on the back of the print must be stated exactly what the photograph represents. A fancy title may be added if desired.

Entries will be divided into two sections, A for readers aged 16 and over, and B for those under 16. They should be addressed: "June Photographic Contest, Meccano Magazine, Binns Road, Liverpool 13." There will be separate sections for Overseas readers, and in each section prizes of 15/- and 7/6 will be awarded. Closing dates: Home Section, 30th June; Overseas 31st December.

# Fireside Fun

Corporal (at a regimental dance): "You see that old fifer there. He's the meanest blighter I ever knew."

Girl: "Do you know who I am? I'm that officer's daughter."

Corporal: "Do you know who I am?"

Girl: "No."

Corporal: "Thank goodness. Good-bye."

Customer (in Chinese laundry): "Is that my name in Chinese marked on my washing?"

Laundryman: "No."

Customer: "Then what is it?"

Laundryman: "Just description. It says tall thin man, broken nose, ugly."

"I'm afraid I shall not be able to pay you for this suit just yet."

"That will be all right, sir. How soon can you pay?"

"Oh, in about three months. That's awfully good of you. When will the suit be ready?"

"In about three months, sir."

Teacher: "There's only one truthful boy in this class."

Smith (in a whisper): "That's me."

Teacher: "Did you say anything, Smith?"

Smith: "No, sir."

It was a very wet day when Mr. Ricks, who was bald, met Mr. Finch.

"My word!" said Mr. Ricks, "It isn't a very nice day for Finches to be out."

"No," retorted Mr. Finch, "and I'm blown if it's any weather for Ricks to be out and no thatch on."

## THIS MONTH'S HOWLER

The Darkey's hour is just before the dawn. This is a well-known African proverb.

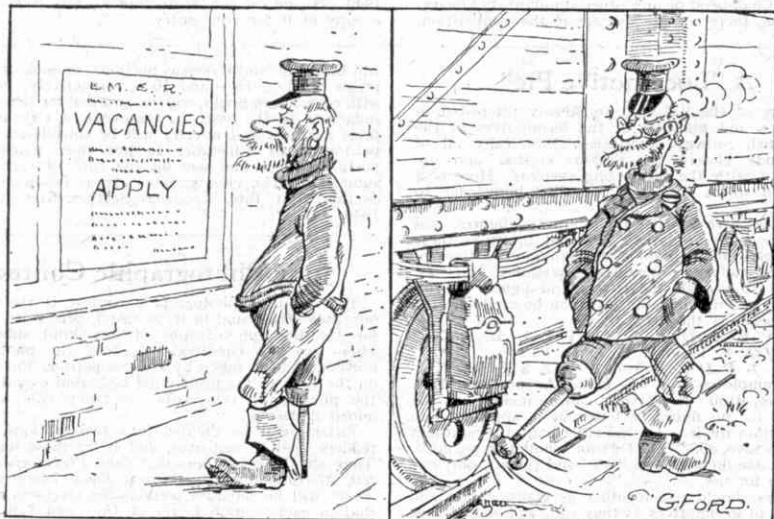

Sailors Don't Care

By courtesy of  
"The Commercial Motor"

## BRAIN TEASERS

### CAN YOU FIGURE THESE OUT?

Here are two easy but interesting number puzzles from "Tracks," the magazine of the Chesapeake and Ohio Railway, which I now pass on to "M.M." readers.

There are three single-figure numbers that give the same result whether they are multiplied together or added. What are they?

See what you can do to straighten out the following sentences so that they will make sense.

1. The sum of 2 and 2 is the product of 5 times plus 2.
2. The sum of 4 and 3 equals two 3's plus the product of three 2's of the sum.

### ANY WAY UP

Here is another teaser from "Tracks." What four-letter word reads the same upside down as it does right side up when the letters are printed in capitals?

### TRACK THEM DOWN

The names of five animals are hidden in the following sentences. What are they?

A timid boy will never be a roamer.

Blow your horn Bill.

Is it right to describe Mac as so wary that he won't answer any question directly?

England is a fine land, the home of liberty.

Monkeys eating nuts always amuse a crowd.

### SOLUTIONS TO LAST MONTH'S PUZZLES

The word square built up from the clues in our first puzzle last month is as follows:

B	R	A	V	E
R	A	C	E	R
A	C	O	R	N
V	E	R	G	E
E	R	N	E	S

In our second teaser, for each letter in the well-known proverb concerned the one before it in the alphabet or the one after it was used. Trial of this code soon gives "Never trouble trouble till trouble troubles you" as the proverb.

The chain in the third puzzle was built up of the following words: Niche; Heath; Thole; Leave; Verge; Geese; Seine; Nerve; Verse; and Sense.

# BOND'S

We will again be able to supply all the requirements of the Model Maker when the war is over and many new items are now on the drawing board getting ready for the time when we can put them into production together with all our other well-known specialities.

We can supply small quantities of materials, screws, rivets, gears and tools, etc., so we will be pleased to know what you are requiring.

No catalogues are available now.

**We will be pleased to purchase any models in good working condition. Kindly send full particulars and price required.**

**BOND'S O' EUSTON ROAD LTD.**

Est'd. 1887.

'Phone:

EUSton 5441-2.

**357, Euston Road  
LONDON N.W.1**



## When Peace comes

The technical skill which has enabled us to produce a vast amount of electrical and mechanical equipment for the Forces will be devoted to the production of

**High-efficiency**

**ELECTRICAL, SCIENTIFIC  
AND MECHANICAL MODELS**  
including

**Electric Motors & Dynamos  
Electrical Outfits, Transformers  
Stationary Steam Engines  
STUDENTS' MICROSCOPES  
TELESCOPES, etc.**

All electrical, scientific, and mechanical models will be made to the highest specifications and subject to the same rigid inspection as our war-time products. Our plans are well advanced and production will begin as soon as the necessary materials and labour are available.

**SIGNALLING EQUIPMENT LTD**

Merit House, Southgate Road  
Potters Bar, Middlesex

Telephone:  
Potters Bar 3133/4

Cables & Telegrams:  
"SEL, Potters Bar"

## YOU CAN MAKE

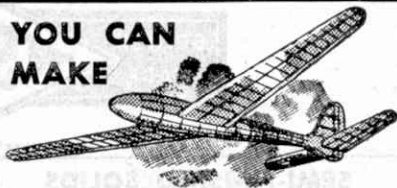

**THIS CONTEST GLIDER** designed to F.A.I. specifications by R. H. Warring which will put up records.

**This Fast Sailing YACHT** which is easy to build by new method of construction, and will out sail all others.

**THIS CLOCK** which can be made with simple tools and materials, and will keep perfect time — and



hundreds of other original and authentic models of Ships, Gallions, Weapons of War, Railway Features, etc., by working to Modelcraft Plans and Construction Planbooks.

**200 HOW TO MAKE PLANS**

Send 3d. and unstamped addressed envelope for Illustrated Price List, Modelcraft Ltd., 77 (MM), Grosvenor Rd., S.W.1

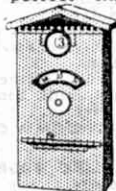

## INDISPENSABLE SERVICE

Bulletin of New Issues, etc. Copy Id. and S.A.E.

**MINT CURRENT STAMPS** (Selection only)

All values to	3d.	6d.	1/-						
Aden	1/2	1/5	2/4	14a	1/7;	1 R.	1/10		
Br. Honduras	1 1/4	1/8	2/5	25c	1/8;	50c	2/11		
Cyprus	10d.	1/10	3/8	18p.	2/4;	45p.	5/9		
Dominica	1/4	1/10	3/-	2/6	2/11;	5/-	5/9		
Falkland Is.	10d.	1/10	3/9	2/6	2/11;	5/-	5/9		
Fiji	1/2	2/2	3/1	1/5	1/7;	2/-	2/3		
Gilbert & E. Is.	1/1	1/11	2/3	2/-	1/11;	2/6	2/4		
Palestine	1/4	2/5	3/6	100m	2/4;	200m	4/8		
Sudan	9d.	1/8	4/6	6p.	1/5	8p.	1/11		
Australia:	Gloucester, 5 set., 1/-;			N.Z. Health:	'43	6d.;			
'44	5d.;	Tonga 1943 Jubilee:	2/-;	Zanzibar:	Al Bu Said	2/1;			
India:	Al Bu Said, 3.6.9p.1.1 1/2, 2a, 1/6;			Poland	1943, 5.10.25 gr., 6d.				
					Postage Extra.				

Importers and Exporters

**LETTS & CO.,** 65, St. Kilda Rd., LONDON W.13

## THE "DANDY" TOY PISTOL

complete with 3 wood shells, price 2/6, by post 2/9. Also the "CHAMP" TOY CANNON, complete with 3 wood shells, price 2/6, by post 2/9.

**BRUCE JOHNSTON, Toy Stores, KEIGHLEY, Yorks.**

**A.B.C. LOCOMOTIVE BOOKS MAIL ORDER DEPT.**  
33, Knollys Road, S.W.16

London Transport Services	2/2
Titans of the Track (L.M.S.)	1/8
Titans of the Track (L.N.E.R.)	1/8
Titans of the Track (S.R.)	2/2
McIntosh Locos. Caledonian Rly.	3/8
G.W.R. Locomotives	1/8
Irish Locomotives	1/8
Minor Locomotives	1/8

Junction X. 56 pages on art paper (fully illustrated) 1/2  
A.B.C. Wallets 1/11





MANUFACTURE SUSPENDED UNTIL AFTER THE WAR

**SEMI-FINISHED SOLIDS**

An entirely new range of non-flying Model Aeroplanes. Ready to assemble, no work required except slight sandpapering and gluing together. Nicely carded and boxed. Hurricane 11c. 7/3. Barracuda 8/-, Thunderbolt 6/9. Defiant 7/-. Typhoon 1b, 6/9. Mess. ME109F. 6/6. Whirlwind 8/9. Spitfire V. 6/6. Mustang 1a 7/6. All post 6d. extra.

1945 lists now ready price 3d. includes Wilson Lorries.

**GEORGE D. CAMPBELL**

Dept. MM, 46, High Street, DUMFRIES

**CIGARETTE CARD COLLECTORS!**

Send for the 1944-45 list of 500 different series. Nearly 20,000 different cards. Price 4d. (Govt. order). Current Bargain List 1d.

**Cards Purchased.** I pay high prices for all kinds in first-class condition. Old or modern, large or small, complete sets or accumulations.

**Especially Required.** Modern Players, Wills, Gallaher, Phillips, Ardath, Carreras, and Orden cards. Send parcels for immediate cash offer.

**R. W. HOUSTON, BCM/EXCHANGE, LONDON W.C.1****SPECIAL PURCHASE S/H WATER LINE MODEL SHIPS (mostly 50-100 ft. to 1 in. Scale):**

CARGO BOATS, LINERS, PADDLE STEAMERS, WARSHIPS, 1/9. 2/-, 2/6, 2/9, 3/9, postage 3d. extra.

**BOOKS:**

- "A.B.C., L.P.T.B.," 2/-, by post 2/2½.
- "A.B.C. MINOR BRITISH RAILWAYS," 1/6, by post 1/8½.
- "L.M.S. TITANS OF THE TRACK," 1/6, by post 1/8½.
- "MODERN LOCOS. AND ELEC. TRACTION OF S.R.," 1/6, by post 1/9.
- "OUR RAILWAY HISTORY," Part III, 3/6, by post 3/9.
- "MODEL SHIPS & BOATS" (Building), 1/6, by post 1/8½.

**TYLDESLEY & HOLBROOK**

109, Deansgate, Manchester 3 'Phone: Bla' 7312

Large stocks of Mechanical and Engineering Textbooks.

**FOYLES FOR BOOKS**

New and second-hand books on all subjects. BOOKS BOUGHT.

119-125, Charing Cross Road, London W.C.2

'Phone: GERrard 5660 (16 lines). Open 9-6 (inc. Sats.).

**BE A RADIO CONSTRUCTOR** and get fine results by building tested and guaranteed designs. My constructional Data Sheets provide complete details, with fine prints and diagrams, which tell and show you how to make the Sets, etc. You cannot go wrong. **DATA SHEETS** for: High Efficiency Crystal Set, 1/6. Super Short-wave 2-Valve Set (Battery), 2/6. Three-Valve Med-wave Set (Battery), 2/-. Two-Valve Amplifier (Battery), 2/6. Microphone, 2/6. Shocking Coil, 2/6. Please include stamp.

**SPARKS' DATA SHEETS, 9, Phoebeth Road, Brockley, London S.E.4.****ELECTRADIX Special Offers!**

**SMALL D.C. MOTOR GENERATORS** by E. D. C. and others. Pocket size for use in receivers to take the place of H.T. Battery, will drive off 12 volt accumulator, output 230v. 30mA. Beautifully made for Government rates. In new condition, 75/-.

**24/-** only for a pair of **P.M. MOVING COIL HEADPHONES**, less headband. This is one of the finest Electradix Bargains ever offered. The 45 ohm ½ in. coil is energised by the famous ALNI magnet. These units can be used as miniature speech mikes, or as a small loudspeaker if matching transformer is used. Each unit is in bakelite case with 3 in. front flange. Per pair 24/-, or 12/6 each.

**MAGNETS.** Midget ALNI perm. steel disc magnets, ½ in. dia. with centre hole ⅛ in. dia., of tremendous magnetic force; unlimited uses, 3/6 each. Horse-shoe permanent steel magnets, various sizes from 3/- each.

**RELAYS.** Telephone, type No. 6, 2-coil polarised, S.P.C.O., 6 volts, 25 ma., 325 ohms 8/6. No. 1A, S.P. on-off, 2 volts, 40 ma, 5/-.. Relay movements 1000 ohms, less blade and contact, 2/6.

For other bargains see previous advertisements of

**ELECTRADIX RADIOS**

214, Queenstown Rd., Battersea, London S.W.8

Telephone: Macaulay 2159

**STUDY AT HOME FOR MATRICULATION**

Wolsey Hall (Est. 1894) will coach you by post for London Matric., School Cert., Engin. Prelim., Lond. B.Sc. Degree, Teachers' exams., etc. Tuition continued free if you fail; low fees, instalments. **PROSPECTUS FREE** from Director of Studies, Dept. GK1,

**WOLSEY HALL, OXFORD**

And now "Precision" card parts for **DETAILED MODERN JUNCTION SIGNAL BOX** (Gauge 00 only). Complete kit 6/9 (by post 7/4); state whether red, yellow or brown brick required. Sold by model firms or direct from **E. Rankine Gray, 726, Christchurch Rd., Boscombe, Hants.**

# Join the Well-Paid Ranks of the TRAINED MEN

**MANY THOUSANDS MORE ARE URGENTLY NEEDED. PREPARE YOURSELF FOR A BETTER POSITION AND BETTER PAY**

*Ambitious men everywhere have succeeded through I.C.S. Home-Study Courses. So also can you. We offer you the benefit of our 54 years' matchless experience as the creative pioneers of postal instruction.*



*If you need technical training, our advice on any matter concerning your work and your career is yours for the asking—free and without obligation. Let us send you full information regarding the subject in which you are specially interested. DON'T DELAY. Make ACTION your watchword.*

**The successful man DOES to-day what the failure INTENDS doing to-morrow. Write to us TO-DAY.**

*Special terms for members of H.M. Forces  
and discharged disabled members of H.M. Armed Forces*

**YOU MAY USE THIS COUPON**

*(Penny stamp on unsealed envelope)*

**INTERNATIONAL CORRESPONDENCE SCHOOLS LTD.**

**Dept. 218, International Buildings, Kingsway, London W.C.2**

Please send me the Syllabus of your Courses in.....

Name..... Age.....

Address.....



**The I.C.S. offer Courses of Instruction in a wide range of subjects, including:**

Accountancy	Hydraulic Engineering
Aeronautical Engineering	Joinery
Aero Engine Fitting	Journalism
Aero Fitting and Rigging	Machine Designing
Aeroplane Designing	Machine-Tool Work
Air-Conditioning	Marine Engineering
Architecture	Mechanical Drawing
Architectural Drawing	Mechanical Engineering
Boilermaking	Mine Electrician
Book-keeping	Mine Surveying
Building Construction	Mining Engineering
Building Contracting	Motor Engineering
Business Training	Motor Mechanic
Business Management	Moulding
Carpentry	Plastics
Chemical Engineering	Power-House Attendants
Civil Engineering	Quantity Surveying
Clerk of Works	Radio Engineering
Colliery Management	Radio Servicing
Commercial Art	Refrigeration
Concrete Engineering	Salesmanship
Cotton Manufacturing	Sanitary Engineering
Diesel Engineering	Secretarial Work
Draughtsmanship	Sheet-Metal Work
(State which branch)	Steam Engineering
Drawing Office Practice	Structural Steelwork
Electrical Engineering	Surveying
Engineer in Charge	(State which branch)
Eng. Shop Practice	Telegraph Engineering
Fire Engineering	Telephone Engineering
Fitting and Turning	Templating
Foundry Work	Textile Designing
Gas-Power Engineering	Toolmaking
Ground Engineer	Welding, Gas & Elec.
Heating and Ventilating	Woodworking
	Woollen Manufacturing
	Works Engineering

*And most of the Technical, Professional  
and Matriculation Exams.*

## STAMP ADVERTISEMENTS

(See also pages 210 and 212)

**BARNET & FORD**

The Stamp Shop, 5b, High Street, Conway, N. Wales  
**LATVIA S.G.1 5m. mint**

This unique item should be in every collection. Printed on the back of German Military Maps, showing part of the territory through which the beaten enemy recently ran.

Blocks of four, or larger blocks *pro rata*, 1/3.

**AUSTRALIA.** Duke of Gloucester set, comp. mint 1/1.

## FOREIGN STAMPS

BOUGHT AND SOLD—HIGHEST PRICES GIVEN  
**FOYLES, 121, Charing Cross Road, W.C.2**

### FREE STAMPS GIVEN WITH EVERY ORDER FOR OUR POST FREE BARGAIN PACKETS

50 Mint British Cols. for 3/11 and N.Z. 1944 Mint Health Comp. }  
 59 Mint French Cols. for 5/11 and 10 Mint Foreign Obsolete }  
 40 Mint French Cols. for 2/11 and 5 Mint Foreign Obsolete }  
 40 Used Mixed For. for 2/3 and 9 Used Egypt Farouk ... }  
 4 Mint Liberia Air for 1/6 and 5 Mint Mozambique ... }  
 8 Mint N.Z. Healths for 2/11 and 15 Used British Colonials ... }  
**FREE**

Just send your p.o. and instructions **TO-DAY** to **GOODE** 19, CLIFTON ROAD RUGBY

### FREE! 25 Different Stamps and Perforation Gauge to approval applicants sending postage to

**S. RILEY & SON (G)**

**4, STRICKLANDS ROAD, STOWMARKET, SUFFOLK**

### NEW COLLECTORS START HERE

The Complete Mint K.G.VI Current Issues to \*3d. from all the Colonies—ADEN to ZANZIBAR and including OBSOLETE.

(A) 72 diff. \*(4d., 3d. and 1d. v.) 6/6. (B) 66 diff. \*(1d. and 1½d. v.) 10/6. (C) 54 diff. \*(1½d. and 2d. v.) 13/6. (D) 54 diff. \*(2d. and 2½d. v.) 15/6. (E) 54 diff. \*(2½d. and 3d. v.) 22/6; or Packets (A, B, C, D and E) 300 diff. \*(4d. to 3d. complete) 65/-. (\* or equivalent in cents.). 250 diff. Whole World 5/-. 300 diff. British Colonials 9/-. All post paid.

The Western Imperial Stamp Co., Trowbridge, Wilts.

## READERS' SALES AND WANTS

### SALES

"Aeromodellers," January 1942—June 1943 and November to December 1943. What offers?—T. Williams, 22, Penketh Road, Wallasey, Cheshire.

Full size Meccano; large number of Parts; excellent condition; complete in stout box.—Horsley, Clifton Road, Elworth, Sandbach, Cheshire.

"Cigarette Cards"; 10 Sets in Albums 15/—; 3d. Lists.—P. Gee, Anstey Lane, Groby, Leicestershire.

"Wonders of World Aviation"; complete 40 parts; excellent condition; S.A.E. for details; offers. Also Books; send stamp for List and Price.—Halliday, The Plains, Calverley, Leeds.

"M.M.'s" January 1942—December 1944 12/—; Morse Buzz on base, £1; excellent condition.—Mr. H. Alsop, Old Schoolhouse, Wartle, Aberdeenshire.

"Meccano Magazines" for sale; January 1935 to December 1942; 7 missing.—P. Nixon 41, Barrack Road, Guildford, Surrey.

# MECCANO MAGAZINE

Registered at G.P.O., London, for transmission by Canadian Magazine Post.

EDITORIAL AND ADVERTISING OFFICE:  
 LIVERPOOL 13, ENGLAND.

Telegrams: "Meccano, Liverpool."

Readers' Sales and Wants. Private advertisements (i.e., not trade) are charged 1d. per word, minimum 1/—, Cash with order. Readers' advertisements are published as soon as possible; inclusion in the first issue after receiving them cannot be guaranteed.

Small Advertisements. 1/8 per line (average seven words to the line), or 20/— per inch (average 12 lines to the inch). Cash with order.

Display. Quotations for space bookings, and latest net sale figures, will be sent on request.

"Meccano Magazines," Dec. 1935—Sept. 1941; Feb. 1942—Oct 1944.—offers to M. Dixon, 124, Norval Road, Wembley, Middlesex. Also large Wooden Station (gauge 0).

Model Yacht, Bassett-Lowke 55/—; Motor Boat Hull 3' 6", 55/—; Loudspeaker, 12/6.—1021 Forest Road, London-E.17.

35 mm. Cinematograph Films 100 ft. 3/—; 200 ft. 5/6; 500 ft. 12/6; all post free.—F. Riddle, 239, Broadway, Southall, Middlesex.

### WANTS

An Electric Train and Rails in working order; state price.—J. Sinclair, Lharbrwyde, Morayshire, Scotland.

Meccano Reversing Clockwork Motor; state price to.—MacMillan, Glenearn, Perth Road, Crieff.

Dinky Aeroplanes; state type/s and price/s; also any Schuco Cars; state type and price.—J. Anson, The Crescent, Gosdoby, Selby, Yorkshire.

"Meccano Magazine" January 1944; good condition; state Price.—G. Hutchings, 45, Parkside Drive, Watford.

All Dublo stock in any condition; write stating condition and price to—Furnston, Plumland Rectory, Aspatria, Carlisle, Cumberland.

Bird's Eggs (any variety) named or un-named; also complete Collections; details, price to—P. Ridgwell, 77, Cambridge Road, Cheshunt.

Hornby Electric Locomotives; any type and any condition; also parts.—Benington, Cranmore, Ballymoney, Co. Antrim.

Meccano Reversing Electric Motor and Transformer.—West, 48, Rhooose Rd., Rhooose, Barry, Glam.

Would pay 8/— for Six Hornby Gauge "0" Straight Rails; Six Curved; One Left-hand Points (2 ft. radius). Good condition.—Jones, "Arddol," Railway Terrace, Machynlleth Montg.

21 in. Model Yacht with Automatic Rudder in good condition. Price and details to—W. H. Wyatt, Brierfield, Tarporley Road, Whitchurch, Salop.

Any Information, Photographs or Books on Tanks and Armoured Vehicles. Please write—T. Williams, 22, Pembott Road, Wallasey, Cheshire.

Dublo Clockwork Points and Rails wanted; also Gauge "00" Rolling Stock. State price.—Coleman, 136, Addison Road, Coventry.

Engines, Rolling Stock, Rails, Transformer and any other accessories suitable for Electric Hornby Dublo.—Whiteley, The Grange, Bletchley, Bucks.

## NEARLY 200 YEARS OLD

Ever since 1760, Hamleys have been known as the children's paradise. Even during these long years of war, with increasing shortage of labour and supplies, we have managed to keep our young customers happy, although stocks of good toys have been hard to obtain.

*We hope that it will not be long now before Hamleys can once more offer all the best and newest toys and games in great variety and quantity.*

**Hamleys**  
ESTD 1760  
HAMLEY BROTHERS LTD

200-202, REGENT ST., LONDON W.1  
(Our only address). Tel.: Regent 3161

Send 2½d. in stamps for full list of aeroplane and warship kits and plans.

## WILSON LORRY KITS



Full Catalogue  
Price 1/-

**WILSON'S LORRIES LTD.**  
Dept. M, BRACKNELL, Berks.

## Do your own Developing and Printing

Azol is a one-solution liquid developer. It is very easy to use. All you have to do is to add water. A quarter of an ounce of Azol and six ounces of water will develop two eight-exposure  $2\frac{1}{4} \times 3\frac{1}{4}$  films. You can buy Azol from any good Photographic Dealer in 3-oz. bottles. It is much more interesting to do your own developing and printing. You miss half the fun of photography if you let someone else do it.

# AZOL

*is the developer to use.  
It brings out the detail.*

JOHNSON & SONS MANUFACTURING CHEMISTS LTD., HENDON, N.W.4  
Established 1743.

THE MECCANO MAGAZINE

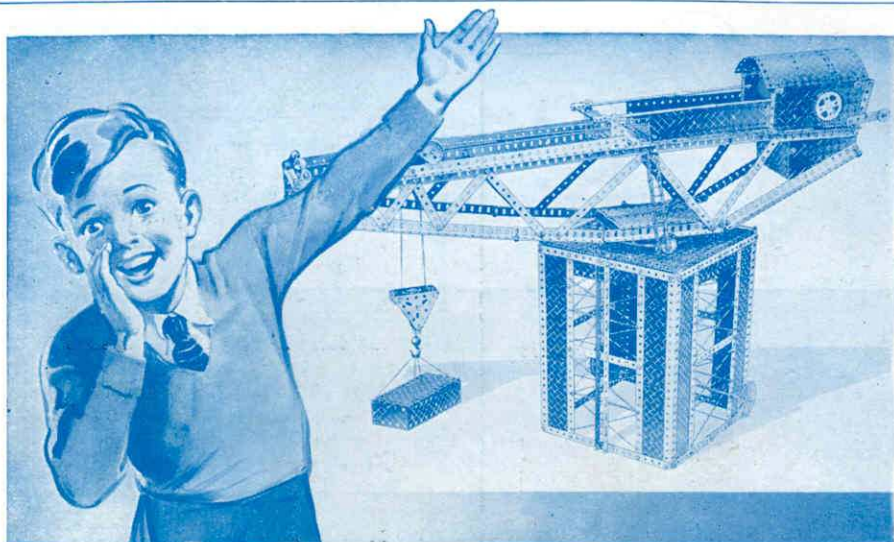

★ MECCANO . . . . .

★ DINKY TOYS . . . . .

★ DUBLO TRAINS . . . . .

★ HORNBY TRAINS . . . . .

VE Day has brought us nearer the time when we shall be able to supply these famous toys.

Look out for our announcements!

Meccano Limited  
Binns Road  
Liverpool 13

