

VOL XXXII No. 12

DECEMBER 1947

# MECCANO

## MAGAZINE



TWO HORSE POWER

6<sup>p</sup>

THE MECCANO MAGAZINE

# DINKY TOYS

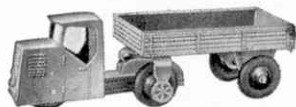

**Mechanical Horse and Open Wagon, No. 33w**  
Price 2/6 each (including tax)



**Jeep, No. 153a**  
Price 2/6 each (including tax)



**Large Open Racing Car, No. 23c**  
Price 1/8 each (including tax)



**Riley Saloon, No. 40a**  
Price 2/6 each (including tax)

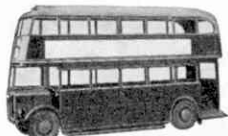

**Double Deck Bus, No. 29c**  
Price 2/10 each (including tax)



**Armstrong-Siddeley Coupé, No. 38e**  
Price 2/6 each (including tax)



**Jaguar Sports Car, No. 38f**  
Price 2/9 each (including tax)



**Lagonda Sports Coupé, No. 38c**  
Price 2/9 each (including tax)

## DINKY SUPERTOYS

These wonderful models are similar in style to the famous Dinky Toys, but much larger. The Foden Wagon, for instance, is 7½ in. long, and the Guy Lorry 5½ in. long. The great amount of accurate detail included gives the models a strikingly realistic appearance.



**Dinky Supertoys No. 501**  
**Foden Diesel 8-wheel Wagon**  
Price 10/- each (including tax)

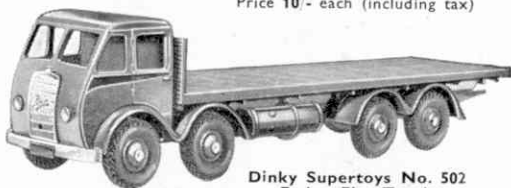

**Dinky Supertoys No. 502**  
**Foden Flat Truck**  
Price 10/- each (including tax)



**Dinky Supertoys No. 511**  
**Guy 4-ton Lorry**  
Price 7/- each (including tax)

MADE IN ENGLAND BY MECCANO LIMITED

# PENGUIN

TRADE MARK

## TUGBOAT "MARY"

AN ALL PLASTIC CLOCKWORK  
POWERED SCALE MODEL OF A

## THAMES TUG



An accurate model of one of London's famous tug boats—the "little ships" of the Thames.

The hull, deck and bulwarks are moulded exactly to shape and a powerful miniature clockwork motor supplies the motive power. All accessories, such as deckhouses, ventilators, bridge controls, lifebelts, etc., are true-to-scale and the Kit also includes cement, transfers, full instructions and drawings.

**9/11**

*Place your order with your local dealer as we are unable to supply direct*

MADE IN ENGLAND BY

**INTERNATIONAL MODEL AIRCRAFT LTD · MERTON · LONDON · S.W. 19**

Look  
around  
**Halfords**

...for every  
accessory that's  
necessary



THE HALFORD CYCLE COMPANY LIMITED  
Head Office: CORPORATION STREET, BIRMINGHAM

**DUNLOP**

The

World's

Master

Tyre





L.B.L.V.  
MINIC TIMBER LORRY

# MINICS for Christmas?

Well, there may be a few, which means that thousands of youngsters are going to be disappointed this Christmas. The overseas demand for these toys is exceptional, so our large Minic plant and staff are working to full capacity to meet our export commitments. However, it is possible that we shall have an excess of certain models, and these will be distributed to the shops at home. MINIC All-To-Scale Clockwork Toys are of all metal construction; fitted powerful clockwork motors; rubber-tyred wheels on most models; and all are beautifully finished in attractive colours. Prices including Purchase Tax from 2/1½. As we do not sell direct, ask at your local toy shop, you may be lucky.

L.B.L.V.  
MINIC VAUXHALL TOWN COUPEL.B.L.V.  
MINIC LORRY WITH CASES

MINIC RACER

L.B.L.V.  
MINIC VAUXHALL CABRIOLET

# Tri-ang REGD. TRADE MARK Toys

L.B.L.V.  
MINIC LUTON TRANSPORT VAN

LINES BROS. LTD., MERTON, LONDON S.W.19, ENGLAND



**"Mars  
ARE MARVELLOUS"**

You'll certainly agree! Just taste these chunks of sheer delicious goodness made with *chocolate* to sustain, *glucose* to energise, *milk* to nourish you.

3½d.

MARS LTD., SLOUGH, BUCKS.



## HIGHER and HIGHER

stands the reputation of Harbutt's "Plasticine." For more than fifty years it has been the only reliable modelling material for home amusement, designing, experimenting, and the handyman. "Plasticine" is ever-plastic and hygienic, and it never deteriorates.

# 'Plasticine'

HARBUTT'S PLASTICINE LTD.  
BATHAMPTON, SOMERSET

*I'm on my toes now -*



*thanks to SPRATT'S  
CONDITION POWDERS*

★ ONE OF THE RANGE OF

## SPRATT'S DOG MEDICINES

*Spratt's range of Medicines includes:—Condition Powders; Worm Powders & Worm Remedies; Fits Tablets; Distemper Powders; Stomach Tablets (for Travel Sickness, etc.) Spratt's Toilet Preparations include:—D.D.T. Soapless Shampoo also D.D.T. Dry Cleaning Powder. SPRATT'S PATENT LTD., 41-47, Bow Rd., London E.3*

DX14E

*You'll find it better  
with*

## Drydex



Drydex torch and cycle batteries throw a brighter beam and last longer

ISSUED BY  
THE CHLORIDE ELECTRICAL STORAGE COMPANY LTD



## BUILD WITH REAL BRICKS & MORTAR

John's a lucky boy, he has a new BRICKPLAYER kit. He's planning a model village—building the houses, cottages and railway station just as they do in real life with trowel, bricks and mortar, and working from detailed drawings. Each model sets solid when the mortar is dry so that it will stand up to hard wear, yet it can be quickly dismantled if soaked in cold water and the bricks used again when necessary.

BRICKPLAYER is obtainable as complete kits with bricks, metal window and door frames, tiled and concrete roofing. A bag of cement and a thirty-two page booklet is also included. From good toy shops and stores at 24/- and 48/- inclusive of purchase tax.

# BRICKPLAYER

THE BRICK AND MORTAR BUILDING KIT

If your toy dealer or store should be unable to supply, write for address of nearest stockist to:

## J. W. SPEAR & SONS Ltd.

ENFIELD, MIDDLESEX

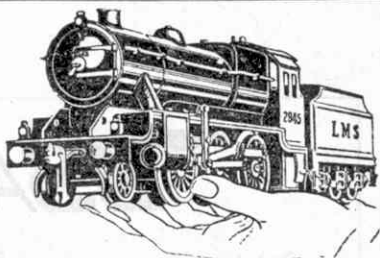

## NEWS OF THE MODELS

Some of our famous models are coming into production. Shortage of materials still retards our efforts in this direction, but we are making headway . . . as you can see from our "Gauge 'O' Model Railway Catalogue" (G17) price 1/-, which shows prices of models available and delivery dates of future models. Send for it to-day.

We can deliver, from stock, all parts for the construction of "PECO-WAY," the most realistic gauge "OO" permanent way. Send for booklet with price list of track parts and other accessories. Price 7d. post paid.

Write also for: "Model Railway Handbook," Standard Edition Price 6/6 post paid



"How to Build a Working Model of a Road Tractor, 3" scale" Price 1/-  
 "How to Build a 3" scale 'Flying Scotsman'" Price 1/-  
 "Laying Permanent Way" Price 6d.  
 "Model Supplies" (L17) Price 6d.

## BASSETT-LOWKE LTD

NORTHAMPTON

LONDON: 112, High Holborn, W.C.1  
 MANCHESTER: 28, Corporation St., 4

**VITALITY BULBS**  
**IMPROVED SUPPLIES NOW AVAILABLE**  
 ADVISE IF YOUR RETAILER CANNOT SUPPLY  
 BECAUSE SLIGHTLY BETTER STOCKS SHOULD  
 NOW BE IN THE SHOPS

VITALITY BULBS LTD. NEVILLE PLACE LONDON, N.22.

## "TRIDENT"

WATERLINE KITS 1 in. = 50 ft.

R.M.S. "Queen Elizabeth" and  
 "Queen Mary"

Length 20 inches . . . 13/1 each post free

R.M.S. "Mauretania"

Length 15 inches . . . 11/1 each post free

I. R. AMIS LIMITED

536, KINGSTON ROAD, LONDON S.W.20

# **BSA** facts on STRENGTH, SPEEDINESS AND SMARTNESS



**STRENGTH** C. I. Thornton, famous Yorkshire cricketer, made several hits of 150-160 yards.

**SPEED** The Cheetah, probably the fastest of all animals, is used in India and Persia for hunting antelopes and other game.



**SMARTNESS** At the Royal Naval College, Dartmouth, the King's Dirk is awarded to the best all-round cadet. Smartness scores points, of course!

*It's strong, it's speedy and it's smart  
Reliable in every way  
The pride of any schoolboy's heart  
It's time you had a B.S.A.!*

Free — Fully-illustrated Catalogue! Just send a postcard to

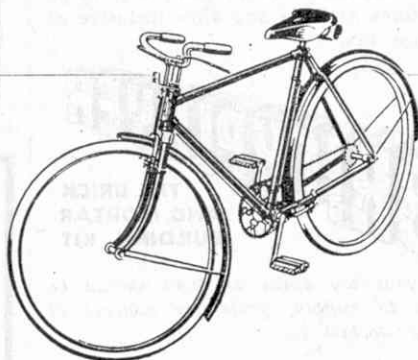

**B.S.A. CYCLES LTD., 31 ARMOURY ROAD, BIRMINGHAM, 11.**



CHRISTMAS GREETINGS TO ALL MY READERS!—From the EDITOR

# MECCANO

## MAGAZINE

Editorial Office:  
Binns Road  
Liverpool 13  
England

Vol. XXXII  
No. 12

December 1947

With the Editor

### Another Cut in Paper

The national crisis has brought about another cut in the quantity of paper allowed for periodicals, and once more I find myself faced with the very unpleasant necessity of reducing the number of pages in the "M.M." The first reduction will be made in the January issue.

The effect of the cut is so severe that it will be very difficult for me to continue all the regular features of the "M.M." while at the same time providing for a good variety of special articles. There seem to be three possible solutions to the problem—to drop one of the regular features permanently, to retain them all by reducing the two-page ones to a single page, or to insert one or more of them in alternate months instead of in every issue. I know that the first plan would bring down on my head a tremendous volume of indignant protest, no matter which feature were omitted. The other two schemes, although they would certainly produce loud groans, would probably be less un-welcome.

In a matter of this kind I attach the utmost importance to the opinions of my readers. I therefore ask every reader to let me have a postcard stating which of the three reduction schemes he prefers, and making any alternative suggestions that occur to him. Send me your postcard as soon as possible, and in the meantime I will make only temporary changes in the "M.M."

### Oil Refining in Britain

Next month I shall publish the first of three articles dealing with oil refining in Britain, the supply of lubricating oil to make a million wheels run smoothly, and the bringing to British industry of many of those parts of the crude oil that yesterday

were waste but to-day are valuable by-products.

The first article will give a short history of oil in the ancient and the modern world and describe what oil gives us in our life to-day. The second will deal with the fascinating work of Manchester Oil Refinery, a specialist refinery that does not produce petrol but is concerned chiefly with lubricating oils and highly refined special oils. The third article will show how chemists and engineers are concentrating on producing new oil products.

At present there are few refineries in Great Britain. Most of our oil and petrol reaches us ready refined, and most of the wealth in the original crude oil is left behind to form the basis of industries abroad. In the chemical age now beginning, Britain must have crude oil and it is here that she must refine it.

### This Month's Special Articles

	Page
Something about Helicopters by C. G. Grey	466
The "Ulster Monarch" by Denis Rebbeck, M.A., M.Sc.	469
Centenary of the Trent Valley Railway, by D. S. Barrie, M.B.E.	470
Pitcairn Island by Capt. H. H. Neligan	472
Puzzle Your Sharp-Eyed Friends by Notman Hunter	474
Dublin Eastern Suburban Trains by Jarlath Dowling	477
Jet Fighter Flying Boat by John W. R. Taylor	479
Limestone Traffic from the Peak by W. McGowan Gradon, B.A.	480
Britain Relights the Seas by Arthur Gaunt	484

# Something about Helicopters

By C. G. Grey

THERE is no doubt to-day that helicopters, that is to say aircraft with engine-driven rotating wings which lift vertically, have arrived, and intend to stay with us. So we may as well proceed to take them seriously. Hitherto such a lot of nonsense has been talked and written about them that I have been compelled to mock them in print, for in some 50 years of engineering, starting when motorcars and even pneumatic tyres did not exist, I have learned that nothing damages or holds up a new movement or mechanism so much as over optimism and boosting too soon before the thing has been developed or become reliable.

In the early days people wasted money on unreliable motorcars and threw them on the scrapheap because they did not come up to the promises of their makers and the boosting they got by the sensation-mongers of the Press, always anxious to get off first with something thrilling, and generally getting off on the wrong foot. Aeroplanes were just the same. Enthusiasts in 1909, when flying really began, talked and wrote as if aeroplanes would be doing by 1910 or 1912 what they are just about

During our great Anglo-U.S.A. fortnight of conferences and exhibitions and flying displays in London, run by the Royal Aeronautical Society and the Society of Aircraft Constructors in the first fortnight of September 1947, I met W. W. Kellett, who is about the most knowledgeable builder of helicopters in the U.S.A. I asked him how long he thought we should have to wait before helicopters were fit for human consumption—that is, could be used as regular air-busses or taxis to take passengers to and from airports away out in the country from and to a central air station no bigger than a couple of tennis-courts in the middle of a town?

He replied: "About ten years," and added: "We have all the aerodynamics of the job whacked. What we have to do is simply an engineering job." Any engineer will admire and appreciate his frankness and intellectual honesty. Many of us can remember that after motorcars ran well enough we still had to wait ten years before we could depend on wheels to stay put, instead of detaching themselves and upsetting us into the ditch, or could be sure that the steering gear would not come off in our hands. And that is where

the helicopter is now.

Leslie Irvin (without a g), the head of the great Irving Airchute Co. (with a g), the man who induced the R.A.F. to use parachutes, in 1930 or so, after he had supplied about 10,000 of them to the Russian Army, from 1925 onward, is now running the Irvin-Bell Helicopter Co. in this country. He told me that helicopters will be safe enough for special jobs—such as

crop-spraying, or rescuing people from glaciers or ice-floes or floods or forests—in five years or so, but they may take longer to reach the air-bus or taxi stage.

There you have the opinions of two sound business men, who are both clever inventors and good engineers. And they are both heavily committed, in finance



Sikorsky S-51 commercial helicopter, showing the long tapering fuselage. Photograph by courtesy of the United Aircraft Corporation, U.S.A.

doing now in 1947. And when aircraft with rotating wings first looked like being practical vehicles, in the form of the Autogiro of 1930, the super-optimists talked about them as if they were already able to do things which serious helicopter designers hope that they may be able to do somewhere about 1960.

and reputation, to the future success of helicopters. So now you have the answer for the cheerful optimists who expect the sky to be full of such machines next year.

### What is a Helicopter?

First of all perhaps I had better explain in simple language just what is a helicopter—for the benefit of those readers who are too young or too old to know all about them already. And perhaps some of the 'tween-age readers may learn a bit too, just as I have learned something about them lately, although I have been watching their development for close on 40 years. Yes! helicopters are, if anything, a little older than aeroplanes.

The shortest description is that a helicopter is a heavier-than-air craft which is lifted from the ground (or water) by an airscrew which is driven by an engine which is contained in the aircraft.

### And what is an Autogiro?

At this point you must be clear about the difference between a helicopter and an autogiro. The helicopter is lifted by a horizontal airscrew, or screws, on a vertical shaft, or shafts, driven by an engine, or engines. The Autogiro (it is a trade name and has a capital letter) is a horizontal windmill, which is towed through the air by an ordinary airscrew and engine in a fuselage (or body) like that of an aeroplane.

You know the little paper windmills on the end of a stick with which children play, and how they buzz round when the owner runs along. Imagine one of those things, very much bigger, towed along with the stick over your shoulder. If you ran faster it would try to lift you off the ground. Make the blades a proper aerofoil shape, like the wings of an aeroplane, put it on a pole (or pylon) on top of an aeroplane fuselage, and tow it with an aero-engine and screw, and it does lift.

Also, if the engine is stopped and the fuselage is tilted down at the right angle it will glide to earth, and will land like an aeroplane with a "dead stick" because the airscrew (called a rotor) will go on rotating, or windmilling. That is to say

it auto-rotates, or gyrates, automatically.

Note those phrases, because one is always hearing of autorotation or autorotation in connection with helicopters. If the rotor of a helicopter does not rotate automatically when the engine stops it means death to anybody on board.



Bell 47 two-seat helicopter hovering near the ground.

Rotation and gyration are the same thing, only that rotation is regarded as slower than gyration—hence the gyroscope.

### The Direct Lift Idea

The idea of direct lift by a driven airscrew is quite as old as the aeroplane. And flapping wings like those of a bird, were earlier on paper than were fixed planes. The Greek word *pteros* means a wing. Hence we had designs for "ornithopters" (*ornis*, a bird, *pteros*, a wing), and "orthopters" (*orthos*, right, as in orthodox, and *pteros*) which were to be more right than a mere bird. They died an early death. The mechanism to move the wings was too complicated and heavy. And now we have "helicopters" (*helix*, a screw, as in "helical," and *pteros*). That is to say, a screw-wing.

The first helicopter which I know got off the ground was made by Ellehammer, a Dane, in 1906—who, incidentally built an ordinary type of aeroplane in 1905, and got off the ground in it in September 1906. Moreover he won a prize at Kiel in June 1908 for the first flight (about 50 yards) in Germany. By 1908 there were flocks of helicopters—on the ground.

Breguet, still famous as a French aircraft manufacturer, built a huge "Gyroplane" in 1906. I saw its second

or third version at the world's first aeroshow in Paris in December 1908. It had two sets of rotors on vertical shafts about 20 ft. apart, each rotor had four arms, and each arm was a complete biplane, so it had 16 "wings." But it never got off the ground. His is still one of the few aircraft firms in France which has not been National-Socialised, and his latest product is a helicopter with two concentric, or co-axial, three-blade rotors, which seems to fly well.

Cornu, in 1908, had a helicopter, which had two rotors, each with three blades like paddles, carried on arms sticking out at the sides; Vuiton and Huber, also 1908, had a design which would look good to-day. It had two rotors, each with two blades. The shaft of one ran inside the shaft of the other, so that they were concentric, and they ran in opposite directions. Also it had an ordinary airscrew pulling horizontally to get it along, if it ever got off the ground, which it did not.

Lorenzen had a much quainter notion. He had one rotor above the pilot and one below him, quite close to the ground, and a "pusher" airscrew as well. No pilot ever risked himself in that maze of screws.

In the U.S.A. in 1909 a man named English had a contraption with two rotors in tandem, each with two paddles of a wonderfully scientific but useless shape. And one named Otto Luyties in 1908 had an apparatus with two oppositely-rotating (or contra-prop, as we should now call them) rotors, which had four sails, rather than blades or planes, apiece. Also a chap called Rickman, in 1908, made an affair like an umbrella, in which the ribs, so to speak, carried fabric strips more or less like aerofoils. He proposed to drive the shaft by gearing built into a tandem bicycle.

There were lots more funny things, but there is no room here to describe them. I have said enough to show that helicopters are nothing new. In fact if you get a book on Leonardo Da Vinci out of the library you will find that in 1500 or so he had plenty of ideas about flying-machines, including helicopters.

#### Between Wars

Up to 1918 there was so much to do in getting plain aeroplanes with ungearing aircrews off the ground and keeping them there that nobody took on the job of experimenting with all the gearing and bevel drives and round-the-corner controls which would obviously be needed in a successful helicopter if it were to do anything more than get straight off the ground and sit down again.

The only possible control was the throttle of the engine. When it was open the machine went up (D.V. and W.P.); when it was closed the machine came down. And if the engine stopped there would have been a sticky mess on the ground. But nobody ever got high enough for that.

Then came improvements in the quality of steel alloys. Tiny spindles and gears did work in 1930 or so which only huge chunks of metal could have done 10 or 15 years earlier. The weight of aero-engines came down from 4 lb. or 5 lb. per horse-power to 1½ or 2 lb. To-day we are down to less than 1 lb. in some types.

Aircrews were produced, the pitch (angle) of which could be varied while an aeroplane was flying. An added complication was the automatic varying of the pitch according to the amount the pilot opened the throttle. Now we have reached the stage of reversing the pitch to act as a brake. All the delicate mechanism thus produced started the helicopter enthusiasts thinking again.

Such gearing at such weights was just what they wanted to drive their rotors and to change the pitch of their rotor-blades and to vary the angle of the rotor as a whole in relation to the body, or hull or fuselage, of their machines, so that they could go forward or backward, or sideways or up or down as wanted.

I think that the greatest impulse to the direct-lift idea was given by that charming Spanish gentleman Senor Don Juan de la Cierva when he invented, or designed, the Autogiro, which I have already mentioned. He showed that if a rotor could be made to autorotate, as his did, as well as lift, a helicopter could be made a safe vehicle.

The Autogiro was introduced to this country in about 1928, and was taken up by Air Commodore J. G. Weir—brother of Lord Weir of Eastwood who had been our second Air Minister in 1918-19, and one of the best we have had. The Weir engineering interests kept it going financially, and the skilful piloting and demonstrating of the machine by Reginald Brie kept up public interest in it, although there did not seem to be any commercial future for it, and few service uses to be found for it.

But constant experimenting with rotor blades and

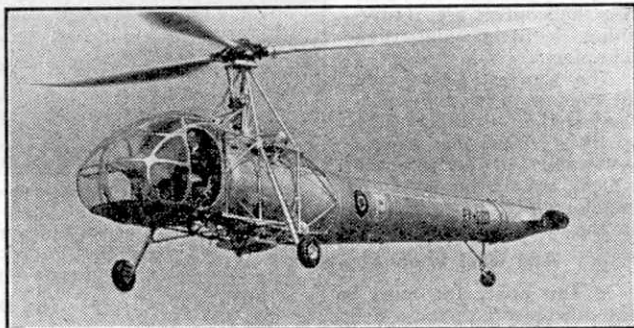

Cierva W.9 helicopter in flight. Photograph "Flight" copyright.

the controlling mechanism of the rotors, the varying of pitch and so forth, produced great improvements as well as new ideas, most of which have been used to develop helicopters.

#### Types of Helicopters

Here I had better explain the different types of helicopters.

A. There is the simple type with a single rotor on top of a body or fuselage, inside which is the engine. Having a single driven screw on top, the fuselage tries to turn round its own axis, or vertical shaft. To keep it straight or to turn it by control, most makes have vertical aircrews (on horizontal shafts) at the tail, driven by long shafts from the engine, to push or pull it straight. One maker carries the engine exhaust to the tail and "puffs" the machine straight. Another (Fairey) has a little airscrew on a stub wing at the right (or starboard) of the body, which keeps the machine straight and helps to pull it along.

B. There is the type with two concentric (or co-axial) rotors, the shaft of one inside the shaft of the other, rotating in opposite directions. Thus the torque, or tendency to turn round, cancels itself out. This class generally has an ordinary rudder and elevator to control its direction.

C. There is the type with two shafts, close together so that the blades of the rotors, rotating in opposite directions, intermesh.

D. There is the type with two rotors, carried far apart, one on each side of the fuselage, each driven by a shaft and gearing (Continued on page 488)



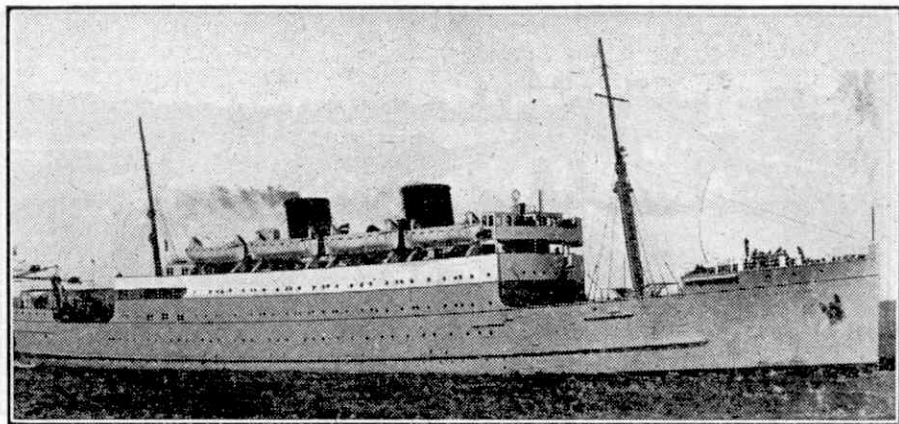

## The "Ulster Monarch"—A Fine War Record

By Denis Rebbeck, M.A., M.Sc., B.Litt., A.M.I.C.E., A.M.I.Mech.E., M.I.N.A.

THE "Ulster Monarch" was built at Belfast in 1929 by Harland and Wolff Ltd., for the Belfast Steamship Company Ltd., and represented, at the time of her completion, the first successful application of the diesel engine to fast cross-channel ships. The vessel was designed for the nightly service between Liverpool and Belfast, and the conception of powering for these ships was as bold as it was successful. In theory the diesel engine was ideal for a service where the vessel lies at a quay all day and sails only at night. Rather like a motor-car the engines could be "switched off" when not required, while electric power for winches could be taken from a shore supply. No stand-by boilers, burning fuel all day long, no warming up of steam-turbines; just start the diesel engines at departure-time and away the ship sailed on her journey. It says much for the designers and builders of this ship, as well as her two sister-ships the "Ulster Queen" and "Ulster Prince," that the service between Liverpool and Belfast was maintained with punctual sailings and arrivals.

When war came in September 1939 the "Ulster Monarch" and her two sisters were to face even sterner trials, for they were quickly seized by the Admiralty. The "Ulster Monarch" helped to carry the B.E.F. to France and afterwards to Norway. She took part in the evacuation there and also at Brest, and transported the first British troops to Iceland.

In October 1940 she was commissioned under the White Ensign as one of the first ships of the Combined Operations fleet. She was used in the training of Commandos, and then returned to trooping in West African waters. Returning to Britain, she embarked the American Rangers, who landed near Oran.

In the North African campaign she distinguished herself in saving the liner "Duchess of Bedford" when the latter ran aground. The next voyage which the "Ulster Monarch" made was via the Cape to Suez, where she took on board the 1st Special Air Service Regiment under Colonel Blair Mayne for the invasion of Sicily. Later, when off Cape Bon, she was hit aft by a bomb which killed two ratings and ignited 400 gallons of petrol.

After repairs had been effected, the "Ulster Monarch" was, only a fortnight later, at the Salerno invasion. On D-Day she was off the coast of Normandy with a force of Canadians. She made 83 trips across the Channel before she was put on service between Tilbury and Ostend.

In September 1945 the ship returned to her birthplace at Belfast to be reconverted into the well-known luxurious "liner" on the Ulster Imperial Line's nightly service. She had covered 100,000 miles and achieved fame as one of the best known of the invasion fleet; no fewer than 250,000 troops had been carried through five of the great invasions of the war. The Queen's Island salutes the "Ulster Monarch."

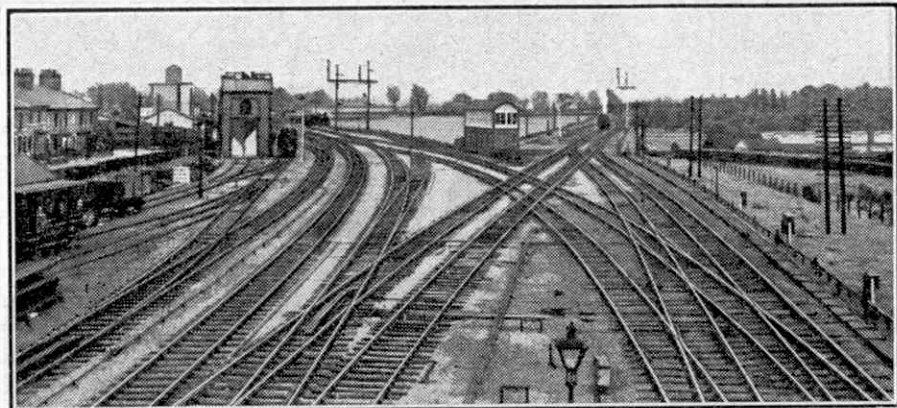

Trent Valley Junction near Stafford station; the Birmingham route is on the right and the Queensville curve brings in the Trent Valley line on the left. This and the lower illustration on the next page are by courtesy of the L.M.S.

## Centenary of the Trent Valley Railway

By D. S. Barrie, M.B.E.

A RAILWAY centenary of more than usual significance is that which occurs on 1st December 1947 of the opening for through traffic of the Trent Valley Railway, which for the past 100 years has formed an integral part of the famous West Coast Route (now L.M.S.) as between Rugby and Stafford. This significance lies in the fact that the Trent Valley Railway was planned and built with the primary object of providing a shorter and quicker route for long-distance traffic between centres already served, or intended to be served, by less direct communication. The Trent Valley was thus the precursor of many railway "cut-offs" subsequently constructed throughout the world, of which several notable examples are to be found, for instance, on the G.W.R.

Through railway communication between Birmingham and Warrington (with connections to Liverpool and Manchester, etc.) and between Birmingham and Euston Square was completed by the Grand Junction and London and Birmingham Railways in 1837 and 1838 respectively. But as Birmingham (New Street) station was not opened for through traffic until 1854, all traffic between places South of Rugby and North of Stafford was subject to change of train or to reversal at the old Curzon Street stations in Birmingham, and in 1838 proposals were accordingly

brought forward for a direct North-to-South chord line which would obviate this detour and its attendant congestion. These proposals were the subject of a good deal of dispute in and out of Parliament between the London and Birmingham, Grand Junction, and Manchester and Birmingham Railways, but in 1845 the Trent Valley Railway was incorporated as a separate company for a line some 50 miles in length from the L. and B. at Rugby to the Grand Junction at Stafford. This undertaking was taken over by the three companies previously mentioned shortly before they amalgamated to form the London and North Western Railway in 1846.

The ceremonial opening of the line of 26th June 1847 must have been an outstanding affair even for the period, when it was the usual thing to celebrate the completion of a railway with processions, glee-singing, massed bands, well-nigh interminable speeches, and a vast banquet. There were present on this occasion 12 Members of Parliament (including Sir Robert Peel, M.P., the Prime Minister, who had cut the first sod of the new railway in his own constituency of Tamworth on 13th November 1845); numerous representatives of the cities and towns concerned; George Hudson, the "Railway King"; old George Stephenson, who had laid out the original Trent Valley

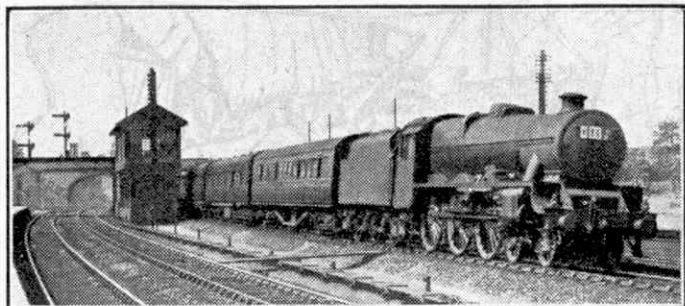

The up "Lakes Express" passing Lichfield (Trent Valley) in charge of 4-6-0 No. 5673 "Keppel." Photograph by W. Leslie Good, Birmingham.

Railway, and countless other notabilities. There was also the young Secretary of the Trent Valley Company, Mr. (afterwards Sir) Edward Watkin, who subsequently rose to be a great figure in the railway world. It came as an anti-climax to this jubilation when the Railway Commissioners, who had been alarmed by the collapse of a cast-iron bridge on the Chester and Holyhead Railway, ordered a postponement of the opening for public traffic of the Trent Valley Railway, pending a further report by the Board of Trade inspecting officer—who had already passed the line—in regard to the cast-iron bridges on this route, which makes no fewer than 20 crossings over rivers and canals.

A start was made with a limited goods traffic in September 1847, and before the end of the year a couple of local passenger trains were put on in each direction, but the opening for through traffic was deferred until 1st December, from which date all the mail trains and some other principal services between Euston and North of Stafford were diverted to the new route. On the same date, Greenwich time instead of "local time" was adopted for all station clocks throughout the L.N.W.R.

The saving of distance via the Trent Valley as compared with via Birmingham amounted to only 8 miles, but the

economy in time was proportionately much greater, and the new link became in effect the main line proper. Splendidly laid out on easy gradients, the Trent Valley is a fine "running road" and was the scene of many notable speed feats prior to the 1939 decelerations. All but 13½ of the 51 miles have three or more running lines, and within this distance there are two sets of water troughs, at Newbold, just North of Rugby, and at Hademore between Tamworth and Lichfield, the relaying of the last-named troughs having been described in the "M.M." of April 1947. Apart from the river bridges, the major engineering works are the Shugborough tunnel (776 yds.) between Colwich and Milford, and the magnificent Queensville Curve by which the Trent Valley line swings round to join the original Grand Junction immediately south of Stafford.

Connection is made between the Trent Valley section and seven other L.M.S. lines, the most complex junctions being with the Leicester - Birmingham and Nuneaton and Ashby Joint lines near Nuneaton. Perhaps the (Continued on page 483)

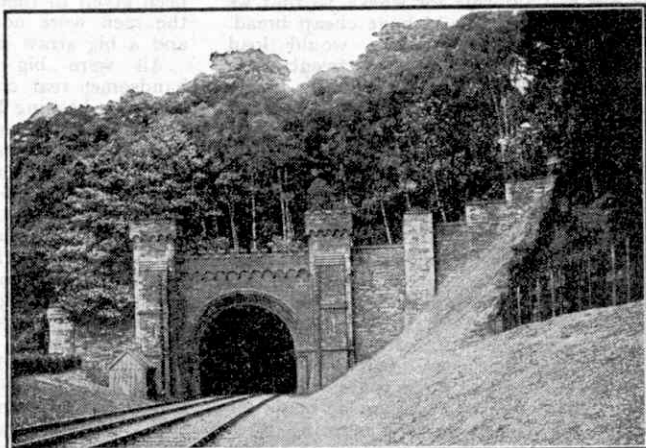

The ornamental northern entrance to Shugborough Tunnel under Cannock Chase on the Trent Valley section of the L.M.S.

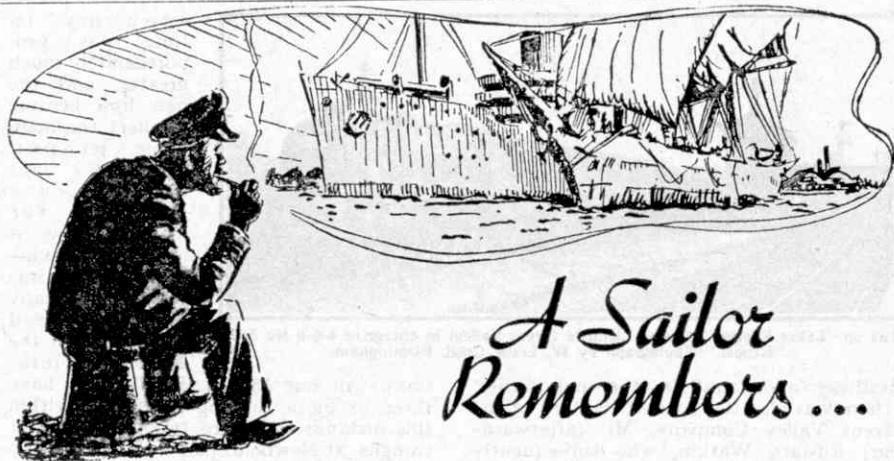

## *A Sailor Remembers ...*

### Pitcairn Island

by Capt. H. H. Neligan

MOST readers will be familiar with the story of H.M.S. "Bounty" and will remember that the mutineers returned to Tahiti after turning adrift their commander and those who remained loyal to him. Some of them landed at Tahiti, and were later tried and punished. Others sailed away and eventually settled on the lonely Pitcairn Island, far out in the eastern Pacific Ocean. I want to tell you a little story about this island.

Years ago our big sailing ships used to go out to California for wheat, so that we in this country should have cheap bread. These beautiful big ships would load wheat, and often as many as twenty at a time would sail together and race home, taking about 100 days on an average for the journey.

I was in one of those "Ocean beauties, that man has ceased to build." We loaded wheat in San Francisco, towed out through the Golden Gate, and spread our white wings for home. The North East Trade winds were strong and we made good progress over the Equator, and into the South East Trade winds.

Almost in the track of these homeward bound ships lay Pitcairn Island, and many ships called there. Our Captain had been there two or three times; this time he had his wife with him, so he made for the island. On the 43rd morning after leaving San Francisco we came up to the island and "hove to," or stopped the ship, by hauling all the sails on the main mast—

back to wind—or "Aback" to use the sea term.

There was very little wind, and we lay about one mile off the shore, and were soon boarded by the natives, who spoke excellent English with a slight Devon accent. They brought all kinds of tropical fruit and fresh eggs in exchange for any old clothes we could spare, and among them were two girls who begged hairpins, cottons and needles from the Captain's wife. They wore any old things that had been given to them by passing ships, but the men wore nothing but a loin cloth and a big straw hat.

All were big, straight, strong and handsome, real children of nature, very religious, begging hymn and prayer books and any Bibles we could spare. We also gave them some sail needles and twine, and paint and brushes; but the two girls prized most some safety pins given by the Captain's wife.

Twilight was very short but it was full moon and a perfect evening, and the islanders stayed on board with their boats and canoes towing alongside till we were about five miles away. Then they got into their little craft to sail home, singing Sankey and Moody hymns, particularly "Beulah Land." They all had good voices and they harmonised well.

So they departed to their beautiful island home, happy and contented with life—a real Utopia. We went on our way to Cape Horn and home.



# BOOKS TO READ

Here we review books of interest and of use to readers of the "M.M." With the exception of those issued by the Scientific and Children's Book Clubs, which are available only to members, and certain others that will be indicated, these should be ordered through a bookseller.

## "THE ATOM AND ITS ENERGY"

By E. N. DA C. ANDRADE, D.Sc., Ph.D., F.R.S.  
(Bell. 10/- net)

The sensational development of the atom bomb has not only excited universal interest in atomic energy, but also has shown us how essential it is that we shall know something of the amazing discoveries that have made its use possible. No better guide can be found than Professor Andrade, a distinguished scientist who can present his story adequately and yet in a manner that we can readily understand.

The author begins with the age-old idea of atoms as the bricks out of which pieces of matter such as copper, quicksilver and carbon are built up. He shows that these bricks are themselves built up of still smaller pieces that by certain methods can easily be chipped off and as easily restored, and explains the methods that have been developed for this purpose. Then he turns to the results achieved, showing how the bombardment of atoms by various tiny particles, given out by radium or produced in vacuum tubes through which electric discharges are passed, transform certain elements into others. The first of these transformations was the making of atoms of oxygen from those of nitrogen, a feat accomplished by Lord Rutherford with simple apparatus described and pictured in the book. More powerful means have since been developed to carry the story further, and the reader will be astonished by the size and complexity of the cyclotron and other instruments of atom research that are illustrated and described by the author.

The climax to these efforts appears to have been reached by the creation of entirely new elements, which so far as we can tell do not exist anywhere on Earth except in the laboratories and workshops of the modern magicians. We are given interesting details of some of these, particularly plutonium, which has achieved the greatest notoriety through its use in the atomic bomb that devastated Nagasaki. The secrets of atomic bombs have not yet been revealed, but the reader learns all that can be made known of their production and use, and of the prospects of turning to peaceful uses the knowledge of atomic energy that has been gained in their production.

Professor Andrade's story of these astonishing scientific developments can be thoroughly recommended to "M.M." readers. The full page plates and many diagrams in the text are well calculated to give a comprehensive idea of the various stages by which atomic power is approaching practical applications.

## "MEN OF THE MAQUIS"

By GUNBY HADATH  
(Lutterworth Press. 6/- net)

Mr. Hadath can be relied upon for an attractive and convincing story, and in his latest book he has turned to the Haute Savoie, the region of France in the shadow of Mont Blanc where the men of the resistance movement fought the Germans during the war. It is with the adventures of a French boy who joined them that we are concerned in the story. For him there was danger not only in actual fighting, but also from treachery and underground attack while he was engaged on special missions, and he had many narrow escapes before the happy days of peace returned to his country.

The book is founded on the actual facts of the relentless war waged by the underground forces in the Haute Savoie, the crags and precipices of which are familiar to the author.

## "THE WORLD'S RAILWAYS AND HOW THEY WORK"

(Odhams Press Ltd. 8/6)

Here is a book for the seasoned "railwayist" as well as the younger enthusiast. In its 320 pages there are more than 250 illustrations, and its 15 chapters provide a mass of information on the wide ramifications of the activities of the iron road.

Roughly one third of the book deals with British railways and their pre-war achievements. Locomotive subjects have a chapter to themselves, and railway working generally, signalling and underground railways all receive attention. Trains on the Continent of Europe, the amazing Alpine systems and the remarkable lines of Scandinavia each take a chapter. Then the reader moves eastward, first to the railways of Russia, with their odd gauge and high-built engines, and then to the neat narrow-gauge equipment of Japan.

Indian, African and Australasian railways and trains are dealt with and in their turn come the railroads of the United States and Canada, so alike in their general large-scale characteristics and equipment, their lengthy hauls, giant locomotives and mighty trains. South American travel over the highest railways in the world and a survey of the railways of Mexico complete the tale.

The book has a good index, doubly useful in a comprehensive work such as this.

## "GREAT LOCO STORY"

By R. L. GREY

(Quadrant Publications. 2/7 post paid)

The title of this booklet is open to criticism, for it gives no real indication of its contents, an interesting account of the locomotives designed by G. J. Churchward, Chief Mechanical Engineer of the G.W.R. from 1903 to 1922. Many of his engines are still running, and his influence has remained strong at Swindon and indeed has extended to other lines, for his use of high-pressure steam, long-lap valves and improved front-end design have come to be recognised as essential in present-day locomotive work.

The book carries the reader from the early years of the present century at Swindon to the close of the Churchward period, and then traces his influence in the later G.W.R. engines. The general principles and constructional features of the Churchward locomotive are well described, and interesting details are given of performance, with useful tables of dimensions and other details.

Useful drawings illustrate the booklet, which can be obtained from Quadrant Publications, 390, Wakefield Road, Huddersfield, price 2/7 including postage.

## "RAIL AND PLATFORM PLANS OF BRITISH STATIONS"

Part 1

(Railway and Technical Press. 5/-)

In the "M.M." last September we reviewed "British Railway Stations Illustrated," Book 1. The present publication, the first of a new series, is a companion to this. It gives 90 diagrams, clearly drawn and well reproduced, of various station layouts, and in most cases the yard layouts adjoining the station have been included, with buildings and lineside structures.

Wayside stations and country junctions are dealt with as well as larger railway centres, and the book will appeal to the modeller intent on finding suitable station layouts for miniature railway purposes, as well as to the railway enthusiast. Copies can be obtained from The Railway and Technical Press, 185, Nutfield Road, South Merstham, Surrey, price 5/3 including postage.

# Puzzle Your Sharp-Eyed Friends

By Norman Hunter (From Maskelyne's Mysteries)

HAVE you ever tried to stand up and recite a simple poem without learning the words? Of course it can't be done. Well, neither must you expect to perform a conjuring trick, even a simple one, to an audience without first practising it a few times.

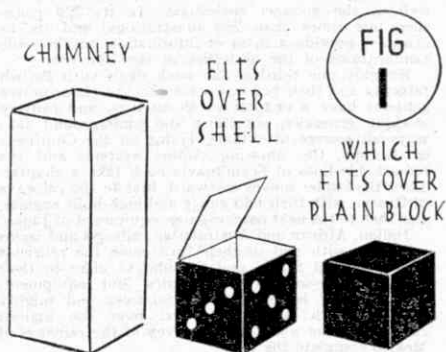

Now that I have warned you against leaping into the middle of a conjuring trick without due preparation, here is the first trick.

## SPOT THE DIE

You begin by showing a sort of square tube or chimney; it is quite empty and the audience can see through it. "This is a die works" you say, "I don't mean it makes things change colour; it isn't that sort of dye though it may turn my face red if it doesn't work." You then hold up a square block of black wood. "This is the raw material for a die," you explain. "I put it into the works"; you drop the block into the chimney. "Then I drop the spots for the die in as well." You drop in some small white paper discs. "And the works works." You lift the chimney and the audience see that the spots have stuck themselves to the block, making a proper die, and a proper whopper too.

**The Secret.** The block of wood is just a block of wood and the chimney is just a square case fitting loosely over the block and a little more than twice its height. The hush-hush part consists of a shell made of thin cardboard, fitting snugly over the block. This shell is open on one side, and the opposite side is hinged with a piece of sticky tape, like a lid. It is best to make the block first, then make the

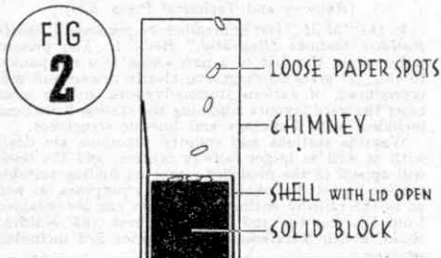

shell to fit it, and finally construct the chimney to slide easily over the shell. The whole affair is illustrated in Fig. 1.

To perform the trick, begin with the shell inside the chimney with the lid of the shell open. Hold the chimney with fingers inside and so hold the lid of the shell too. The inside of chimney and shell are painted black so the chimney looks quite innocent. By the way, the outside of the shell is decorated with white paper spots to make it look like a die.

Put the block on the table, place the chimney over it and drop in your loose paper spots (Fig. 2). Tap the chimney, thus causing the lid of the shell to fall and cover the loose spots. Lift the chimney and reveal the block now covered by the shell, and bow to the applause.

Our first trick with a square tube having come off successfully, let us now fire off one with a round tube.

## NO COUPONS

A nice topical title. You pick up a sheet of paper, show both sides of it and roll it into a tube. "Let us suppose you have no sweet

## HOW TUBE IS ATTACHED TO PAPER

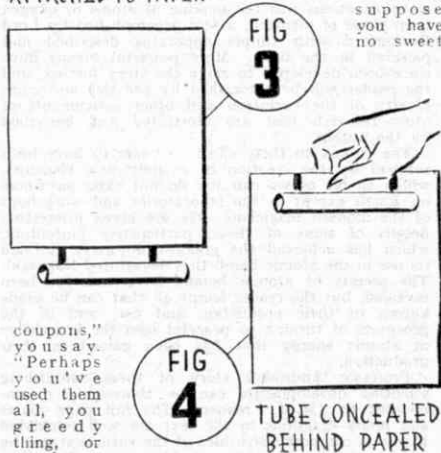

coupons," you say. "Perhaps you've used them all, you greedy thing, or perhaps you've

lost them. If you're a wizard you need never be at a loss for a lollipop because you can always conjure up some confectionery, like this." You tilt the tube and no end of the most agreeable sweets come tumbling out on to a plate. Then of course you hand them round and the trick is a great success.

**The Secret.** The most important part of the secret is to persuade father to part with some of his ration for the sweets, so that you don't have to hand your own round; but that I can safely leave to you. The other part is connected with the paper used for the tube. In fact it is actually connected to it. It consists of a length of cardboard tube fixed to one of the short sides of the paper with short lengths of tape. The paper should be thick brown paper, free from folds or creases, and should measure along its short sides about three inches more than the length of the tube. (See Fig. 3).

The paper lies on your table with the tube hanging over the back edge, out of sight. Lift the front edge

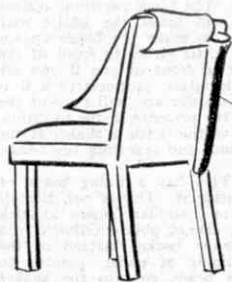

FIG  
5

BAG TO RECEIVE  
STICK, FIXED  
BEHIND BACK  
OF CHAIR

of the paper, letting the back edge remain touching the table, and draw attention to the fact that it is a plain sheet of paper. Let it drop on the table and pick up the back edge, thus showing the opposite side of the sheet. In doing this you automatically bring the hidden tube up behind the paper as in Fig. 4. Now roll the top edge of the paper over to the back and so round the hidden tube. This hidden tube you have previously filled with sweets, plugging the ends lightly with pieces of coloured tissue paper to keep the sweets from dropping out.

All you now have to do is give the tube a sharp shake over a plate and out will gush the sweets. Some of them should be of the kind that are wrapped in coloured paper, and the bit of paper used to plug the tube will then not be noticed.

Sweets are sometimes sticky things, which brings me to the next trick which is also done with a sticky thing, in fact with a stick.

#### LOST PROPERTY

The stick is a black one about two feet long. If you like, it can have white tips, like the conventional conjurer's magic wand. You rap it on the seat of a wooden chair to show that it is solid, then you wrap it again, this time in a sheet of newspaper.

"You find strange things in the newspapers nowadays," you remark. "Sometimes it's a house to let, sometimes it's fish and chips, and this time, as you can see, it's a conjurer's magic wand. Only as this stick is a magic stick it doesn't stick anywhere for long, so you don't find it." You crumple the paper into a ball and toss it aside. "Perhaps you think the people at the lost property office will wonder what it is when it arrives there. Don't worry, it hasn't gone there, here it is." You reach down and remove the missing stick from the leg of your trousers.

**The Secret.** The magic wand is not a highly complicated and plentifully collapsible article. It is just a rod of wood. But over it fits a paper tube. This paper tube is made of shiny black paper with

FIG  
6

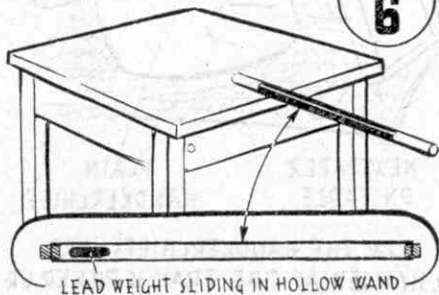

LEAD WEIGHT SLIDING IN HOLLOW WAND

pieces of white paper pasted round the ends to make it look like the real stick. If the chair has an open back you must hang a cloth over it, and behind the chair you fix with a drawing pin a long narrow cloth bag big enough to take the stick. The bag should have a wire ring in the mouth to keep it open. You can use quite a long stick because the bag can go down behind one of the legs of the chair if necessary. The paper for wrapping the stick is laid over the back of the chair as shown in Fig. 5.

Show the stick with its paper covering and slap it loudly on the chair to show that it is solid. Now, holding the stick in your right hand, you pick up the newspaper with the same hand by the back edge. This will bring your hand behind the chair and you can easily let the solid stick slide out into the bag. All you then have to do is wrap the paper tube in the newspaper and crush it into a ball. The stick

FIG.  
7

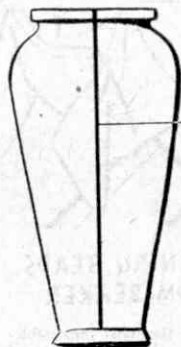

CARDBOARD PARTITION  
IN GLASS JAR



FIG  
8

HOW JAR IS HELD  
TO MAKE BEADS  
APPEAR

you take from your trouser leg is a duplicate which you have previously put there, with the lower end tucked into your shoe.

#### SPOOKY INTERLUDE

This isn't a trick, at least not in the usual sense. It is one of those uncanny little things you might expect to keep happening if you were dealing with a real magician. The magic wand you have been using for the previous trick you casually put down on the table with only the tip of it resting on the table. To the surprise of the audience it stays there. In fact every time you put it down you leave more than half of the wand unsupported, but in defiance of the laws of gravity it doesn't fall down. This usually has an effect on any gravity in the audience and makes them laugh.

**The Secret.** The wand in this case is a tube made either of thin cardboard or thin, light metal. The ends are plugged with wood and a short length of lead slides up and down inside the wand. By letting the lead weight slide gently to one end and putting that end on the table, or resting it on the edge of a

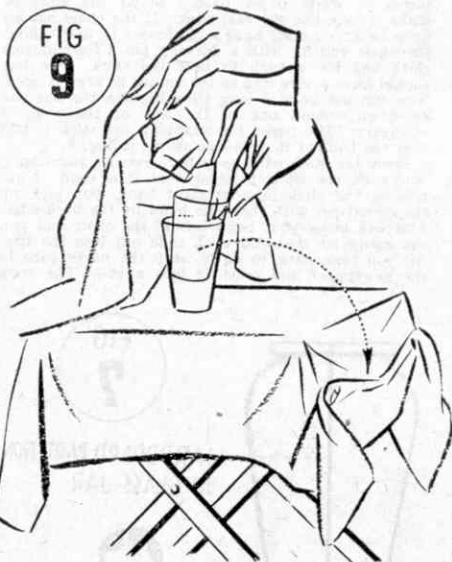

### HOW LINING CONTAINING BEADS IS REMOVED FROM BEAKER

glass, etc., you make it stay in the most impossible-looking positions. Fig. 6 shows the construction of the wand. The lead should be covered with a piece of velvet so that it cannot be heard sliding inside the wand.

Now off we go on another full dress trick.

#### THIS'LL BEAD YOU

No, I haven't got a cold in the head. Beads are what you are going to use for the trick, a large fancy glass bottle full of them. You pour them into a tumbler and cover it with a handkerchief, then, holding the empty bottle in your hands, you go on: "You have just seen me empty the beads from this bottle into that glass. Or at least that is what you thought you saw me do. Everybody thinks conjuring is a case of the quickness of the hand deceiving the eye, but this time the quickness of your eyes deceived themselves. I didn't pour the beads out of the bottle, they're still here."

As you say these words the audience see the bottle suddenly become full of beads again. You pour them out on to a tray, whisk the handkerchief off the glass and show that it is quite empty.

**The Secret.** By this time you will perhaps have guessed that there are two secrets to this trick—the secret of the bottle and the secret of the glass. Quite right. The bottle, which should have a wide mouth rather like one of those vase-cum-bottles that bath salts used to be kept in, is divided vertically down the centre by a black cardboard partition, as shown in Fig. 7. At the start of the trick both sides of this partition are filled with small beads. When you pour the beads out you hold the vase with the partition flat-on to the audience, and keep one hand partly over the mouth of the vase so as to prevent the beads from falling all over the place. Really of course you do it to stop those behind the partition from coming out at all.

The glass on your table is standing in front of a black curtain, or if no black curtain is handy it can have a black box containing the things for other

tricks standing behind it. The black partition against this black background will make the bottle look empty. When you want to make the beads appear in the bottle, hold the bottle either in front of the black curtain or hold it in front of you if you are wearing a dark suit. The glass, particularly if it is fancy glass as such jars usually are, will prevent the audience from detecting the presence of the partition. At the right moment, give the bottle a shake, at the same time turning it round and revealing the beads. (See Fig. 8).

Now for the glass. This has a lining made of celluloid fitting nicely inside it. This is not difficult to make, using Durofix or a similar cement to stick the celluloid; but if you cannot obtain celluloid you can use a coloured opaque beaker instead of the glass and make your lining of paper, painted to match the beaker. The beads go into the beaker and into the lining. As you draw the handkerchief over the beaker from the front you pick the lining out with the thumb and forefinger of one hand and drop it into a pocket at the back of the table, formed by pinning up the back of the table cloth. Fig. 9 will make this clear.

Finally we will sign off with

#### DESIGN FOR MAGIC

The design in question is painted on a small tray. "Of course," you say, "it is always better to have designs on your own property rather than on other people's." You show a white handkerchief, fold it and lay it on the tray. "This is just a question of thought transference," you explain. "You thought the design was on the tray; now if you thought it was on the handkerchief instead I could show you that you were quite right. You unfold the handkerchief, and (Continued on page 488)



### HOW THE HANDKERCHIEFS ARE CHANGED AS THE TRAY IS PICKED UP



# Dublin Eastern Suburban Trains

By Jarlath Dowling

WHAT may be termed the eastern suburban section of the former Great Southern Railway of Ireland, now known as Coras Iompair Eireann, lies between Dublin and Greystones on the Wicklow coast. The section has both an inland and a coastal route as far as Bray, where the two unite and continue in a single-track main line through Bray Head Tunnel to Greystones. Here the suburban service terminates while the main line continues to Wexford. There is, however, an "inner suburban" service on the inland

to the gradient and a very weak bridge on the direct route via Newcomen Bridge Junction, but they run along the southern section as far as Glasnevin Junction where they are switched on to the Midland section.

Signalling on the coastal section is electric as far as Dun Laoghaire and manual semaphore thereafter. At Dun Laoghaire is an interesting feature in that on the back of the down "home," which is a semaphore signal, there is fixed a colour light unit which does duty for the up advanced "starter." On the inland section the signalling is mostly semaphore but in the vicinity of Harcourt Street is electric.

The locomotive stock is varied and interesting. For the Wexford services Great Southern 4-4-0s of Coey's class "D4," a deservedly popular type, are stabled at Canal St. There is no turntable at Canal St. so that when these engines run into Westland Row from Wexford they have to run light down to Amiens Street to be turned.

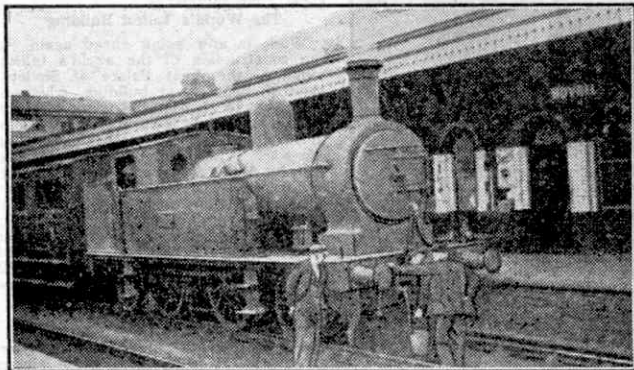

A local train at Amiens Street Station. The staff are "milking" the engine to obtain hot water for carriage washing purposes.

route that terminates at Foxrock.

The inland route begins at Harcourt Street Station, an interesting place with a curious layout. The coastal route starts from Amiens Street, a through station with connections to the loop line that gives access to the former Great Southern and Midland Great Western systems. From Amiens Street the line makes its way to the junction, serving various coastal points. The stations of principal interest are Westland Row, and Dun Laoghaire, formerly known as Kingstown.

Westland Row is a fine through station with an arched glass roof, and an all-electric gantry signal-box is situated over the track. Since the closing of Broadstone passenger station all services along the old Midland Great Western main line, such as those between Dublin and Galway, Mayo and Sligo, are started from Westland Row. They do not run directly on to the Midland section at Amiens Street owing

Two of the ex-Midland Great Western 2-4-0s work regularly on the coastal section between Amiens St. and Greystones. These engines are great favourites on the inland section too.

Foremost among the tank engines on this section is class "P1" 2-6-2 No. 850. Another interesting engine which works fairly regularly on the inland and occasionally on the coastal section is the Beyer-Peacock 4-6-0 tank No. 466 from the former Cork Bandon and South Coast line.

The engine shown in the illustration is a Great Southern 2-4-2 tank of class "F1" originally belonging to the Dublin and South Eastern Railway. Two of the station staff are "milking" the engine by means of the steam heater hose to obtain hot water for carriage washing. The driver is looking on tolerantly, for this is a favourite dodge at Amiens Street and probably is not unknown elsewhere.

# Engineering Notes

## An Interesting Motor Scythe

The machine illustrated on this page is a motor driven scythe, specially designed to cope with work that is beyond the capacity of a lawn mower but does not justify the use of an ordinary agricultural

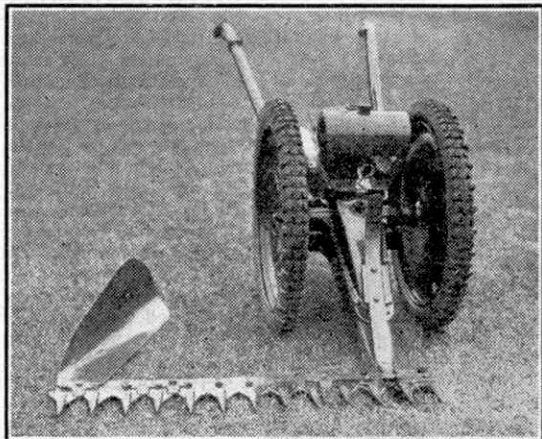

The useful motor scythe described on this page. It is manufactured by John Allen and Sons (Oxford) Ltd., to whom we are indebted for our illustrations.

mower. It is therefore specially suitable for cutting tangled grass and other growths such as brambles, bracken and weeds. It is known as the Allen Motor Scythe and is a product of John Allen and Sons (Oxford) Ltd.

The machine is operated by a  $1\frac{1}{2}$  h.p. Villiers petrol engine. This drives through a constant mesh gear-box and an easy turn ratchet mechanism, large diameter driving wheels and the cutter bar at the front of the machine. The engine has ample power to drive the machine over uneven ground and slopes, and as it can be operated by unskilled labour the machine is specially useful on small estates.

A special feature of the control mechanism is a safety clutch, which is incorporated in the drive to prevent damage to the mechanism if solid obstacles such as stones are encountered while cutting. This clutch cuts out the drive automatically when a solid object is struck and transmits it again when the obstacle is removed. It is estimated that with this machine an average worker can cut one acre of growth in two hours.

A number of special attachments are available for use with the machine, including a hedge trimmer, light hoe, spray pump and a light trailer. These greatly increase the usefulness of the machine.

## A New Scheldt Tunnel

A new tunnel under the Scheldt River, Belgium, is being built at Antwerp. Before the war there were two separate tunnels under the river, for vehicles and pedestrians, linking the city of Antwerp and the borough of St. Ann on the other shore of the river. The vehicle tunnel is 6,920 ft. long, and accommodates a roadway 22 ft. wide with two lines of traffic, and on each side a service sidewalk. The tunnel for pedestrians has an internal diameter of 14 ft. and is equipped with escalators.

The new tunnel is being built to accommodate increasing pedestrian traffic, and it will be reserved exclusively for the use of pedestrians. Constructional work at St. Ann started recently and is progressing rapidly.

## The World's Tallest Building

Work is now going ahead again on the construction of the world's tallest building, the great Palace of Soviets, Moscow. This great building, which is intended to house the Civil Service Departments of U.S.S.R., was begun in 1939 but work was suspended during the war. When completed the building will be 1,400 ft. high, thus exceeding the height of the famous Empire State Building in New York. At the top will be a huge statue of Lenin, 330 ft. high, made from stainless steel. The main framework of the palace is composed of five steel drums, each consisting of 32 outer and 32 inner pillars, linked by radial and tangential girders.

## Exploring the Ocean Floor

A specially designed ocean craft, called a Bathyscaph, is being built for Professor Piccard, the famous stratosphere explorer, who intends to use it in a new expedition to study the bed of the Atlantic Ocean. The Bathyscaph is a steel shell 23 ft. long and 10 ft. wide, which contains seven compartments filled with a special light gas. Inside this will be a spherical explorers' car, in which the scientists will live and work. The device will act as a submarine, and is designed to withstand a pressure of 24,000 tons.

Professor Piccard and his companions expect to reach depths up to 20,000 ft.

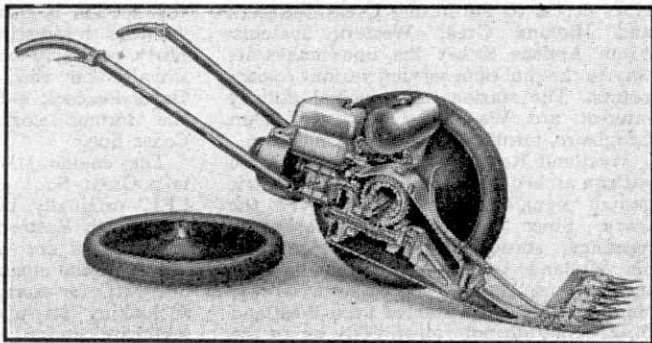

The scythe with casing and one wheel removed to show the mechanism.

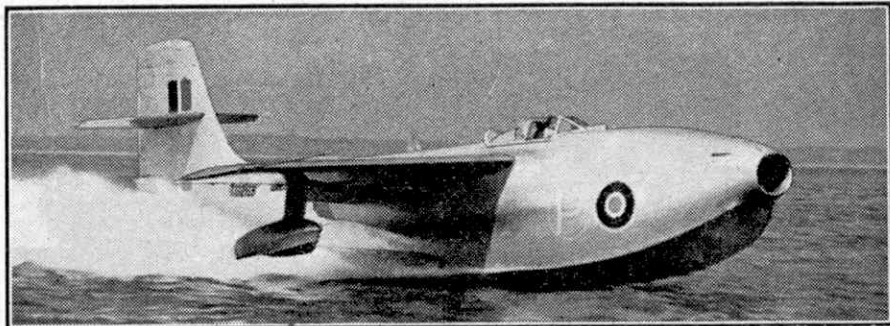

Photograph "Flight" copyright.

## Jet Fighter Flying Boat

By John W. R. Taylor

THE Saunders-Roe SR/A1 jet-propelled flying boat fighter is an outstanding example of the British designer's ability to produce an unorthodox yet highly successful aeroplane.

A machine of this type would have been of incalculable value to the R.A.F. during the war. The Luftwaffe drove us out of Norway because we had no air bases there. Years later, in the Pacific, Allied progress was still being halted for the same reason. And yet nature had provided hundreds of ready-made "airfields" in each war zone, from Norway's fjords to the Pacific atolls. The potential value of water-based fighters was appreciated as early as 1940. Unfortunately, it was found that fitting floats ruined the performance of even the "Spitfire," and the idea was scrapped.

Nobody seemed to consider the possibility of a flying boat fighter, perhaps because most flying boats are large, rather tubby, leisurely aircraft. Anyway, there was also the problem of providing propeller clearance when the machine was on the water. But now, by combining the newest form of aircraft propulsion with a revolutionary concept of small flying boat design, Saunders-Roe have given the Royal Air Force a very powerful new weapon.

Many problems had to be solved, from the obvious one of how to pack enormous power into a small airframe to such things as how to pick up moorings with only a pilot aboard. Saunders-Roe have not only solved these and scores of other difficulties, but have produced an aircraft which combines compact, pleasing lines with high performance and good handling

characteristics both in the air and on the water.

Much of the credit for this must go to the SR/A1's two 3,500 lb. thrust Metrovick F2/4 "Beryl" jet engines. They combine high power with a small diameter, making it possible to mount them side-by-side in the hull. The fuselage is bulged at each side aft of the wings to permit ejection of the hot gases clear of the hull and under the tailplane. The outlets are thus in the ideal position, while the side-by-side arrangement ensures a high rate-of-roll and good single-engined controllability. The air intake is right at the front of the hull and tests have proved that it is well out of the way of spray.

The SR/A1's four 20 mm. cannon too are carried in the hull, with the result that the high speed characteristics of the 46 ft. span thin wings are completely unspoiled by bumps, holes or engine nacelles. A high wing was an obvious choice to clear the water and, although this necessitated fitting stabilising floats, they retract in flight to reduce frontal area. The pilot's comfort and safety have been given special consideration; the cockpit is pressurised for high flying and fitted with an ejector seat. Finally, an ingenious scheme of automatic mooring has been devised, so that the pilot has only to taxi over the mooring rope for the aircraft to moor itself.

Performance of the SR/A1 is still secret, but it has a top speed of over 500 m.p.h. It is undoubtedly a great technical achievement of which its designers can be justly proud.

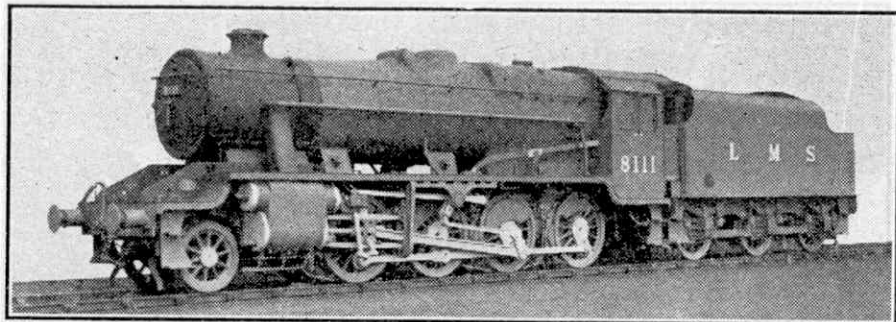

L.M.S. No. 8111, a 2-8-0 heavy freight engine of Class "8F." Photograph by courtesy of the L.M.S.

## Limestone Traffic from the Peak

By W. McGowan Gradon, B.A.

AN arduous but little known duty carried out by the L.M.S. 2-8-0 freight locomotives of class "8F" is the working of Imperial Chemical Industries limestone trains from the quarries at Miller's Dale, Derbyshire, to the works at Winnington in Cheshire, a distance of about 45 miles.

This calls for some four or five daily workings in each direction. Vacuum-fitted steel bogie hopper wagons are employed, each wagon having a capacity of 43½ tons and an unladen weight of just over 22 tons. The wagons are painted grey, with "I.C.I." in raised red letters on the sides. The usual load for an "8F" is 17 loaded wagons and a 20-ton brake, an "all up" weight of just under 1,160 tons to be lifted by the 125-ton 2-8-0 which has a tractive effort of 32,438 lb. With their two 18½ in. by 28 in. cylinders and small driving wheels the "8F" class are ideal for the job.

The road is a hard one. Starting from Miller's Dale, the old Midland main line from Derby to Manchester (Central) is followed as far as Cheadle Heath. The trains pass through Disley Tunnel, 2 miles 346 yards long, the third longest tunnel on the L.M.S. and the sixth longest in Britain. From Cheadle Heath the Manchester avoiding line of the Cheshire Lines Committee is used, and a connecting spur to the Manchester South Junction and Altrincham electrified line enables the trains to reach the Cheshire

Lines track running from Altrincham through Hale and Knutsford to Northwich and Chester.

Powerful as the "8Fs" are, when they are fully loaded they require assistance from Miller's Dale up the 1 in 90 to Peak Forest. This is usually provided by a class "4" 0-6-0 which pilots the 2-8-0 as far as Peak Forest Station advance starter signal. Here the 0-6-0 is detached and the "8F" begins a cautious descent through Peak Forest Tunnel. But it is just south of Altrincham Station on the C.L.C. that the best "fireworks" can be seen on occasions. Starting just beyond the station platform there is a short, sharp gradient of 1 in 128, with very severe curvature up to Hale. As the "8F" is usually held at Deansgate Lane Junction until a path can be found for her between the Altrincham electrics, there is only about half a mile from there to the foot of the gradient in which to employ "rush tactics."

One of these heavy limestone trains coming through Altrincham station towards Hale is a most impressive sight. The regulator is always wide open and the engine is in full forward gear, resulting in a tremendously hard "bark" from the exhaust. On occasions, when very wintry conditions have prevailed, the writer has seen one of these trains "stalled" between Altrincham and Hale until another engine has been obtained to assist in the rear. Normally however the "8Fs" handle their big loads most efficiently.

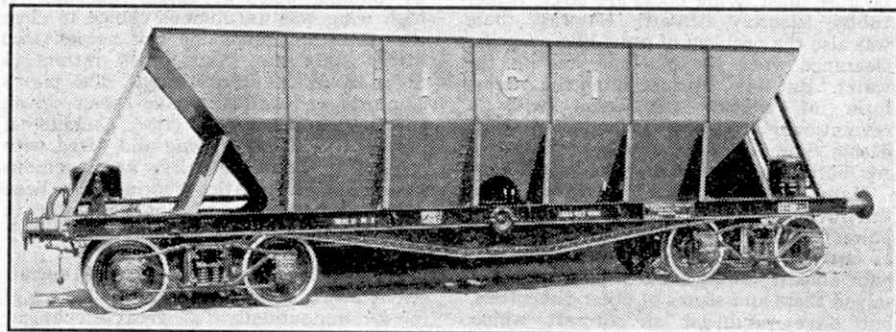

A high-capacity steel hopper wagon used for I.C.I. limestone traffic. Photograph by courtesy of the builders, Charles Roberts and Co. Ltd., Wakefield.



# Photography

## Snow and Frost Pictures

SNOW and frost bring discomfort to many people, especially those who have to work outdoors or to make journeys, but to the photographer they bring com-



"Snow and Frost in the Marsh." A charming photograph by H. Bastin, Reading.

pensations in the form of new and beautiful subjects for his camera. It is unfortunate that the majority of amateurs seem to put away their cameras in late Autumn, with the result that, when the rare opportunity comes of making pictures of really good snow scenes, apparatus is not ready. The wise photographer will make sure that his camera is always available with a film.

The beauty of a snow scene depends upon variety in the combination of light and shade. For most purposes sunshine is an absolute necessity; even the most promising snow scene makes a dull and uninteresting picture if there is no sun to give sparkle and the necessary shades. On the other hand bright sunshine will often turn quite a dull view into a charming picture.

Generally speaking the best time to make an exposure on a snow scene is in the morning when the sun's rays are breaking through the mist. It is usually necessary to have something dark in the foreground, a tree, a shrub, a wall, or something of that kind to give contrast.

Sometimes one or two figures in the foreground will serve the purpose even better. Pictures taken while snow is actually falling are seldom successful, and it is not worth spending films on them.

Frost provides pictures with a special charm of their own. Some of the most effective frost pictures are seen in sunshine after a combination of frost and fog. With such pictures it is quite definitely the early bird that catches the worm, for the sun quickly spoils the delicate beauty of the frost tracery.

Winter sports make good subjects, but most of them require a fast shutter speed, and bright sunshine is essential. More attractive pictures can often be made of children playing in the snow or building a snow man.



"Snowman." A typical snow picture by J. B. Oxenburg, Felixstowe.



"Snowed-up." A Leyland Titan Bus caught in a heavy fall. Photograph by Leyland Motors Ltd., Leyland, Lancs. Although submerged for nearly 24 hours, the engine started straight away once the vehicle had been extricated.



# Railway Notes

By R. A. H. Weight

News from the L.M.S.

A reader writes that the new type "4F" 2-6-0s to be built at Horwich are to be numbered from 3000 upwards. The cylinders, of diameter 18 in. and stroke 28 in., are being made of cast steel, with cast iron liners for both cylinders and valves. The

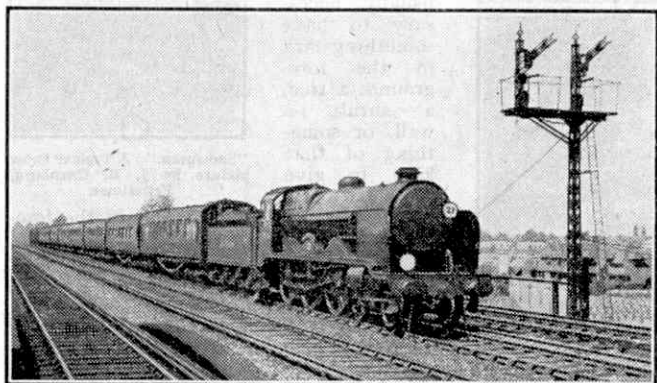

S.R. 4-6-0 No. 2333 "Remembrance," of Class N15X, in its present form, at the head of a Bournemouth-Waterloo express passing Hershham. Photograph by C. R. L. Coles.

working pressure is 225 lb. per sq. in. These engines are no doubt part of a series of 20 of a new design incorporating double blast pipe and chimney, as well as all the latest standard features, recently announced by the Company in its 1947 locomotive building programme as replacements for some of the well known standard "4F" 0-6-0 freight engines, the design of which dates back to 1911.

We have received the log of a recent lively run on the morning Euston-Birmingham-Wolverhampton express with a 13-coach load of just over 400 tons gross hauled by rebuilt "6P" 4-6-0 "Patriot" No. 5528 of Bushbury shed. The restart after picking up passengers at Watford was five min. late. An excellent ascent was made of the gradual rise to Tring, which station, 14½ miles, was passed in just over 17½ min., speed over the 3½ miles from Berkhamsted averaging 55½ m.p.h. Then followed some very fast travelling, with a maximum of 84 m.p.h. near Sear's Crossing and an average of 82 along the 4 miles between Cheddington and Leighton Buzzard, speeds reminiscent of pre-war velocities. Bletchley, 29½ miles, was reached in 31 min., now came a permanent way repair slowing, but the arrival at Blisworth was made

in but a few seconds over the 50 min. allowed for the 45½ miles start to stop from Watford. Thanks to smart station work the arrival in Birmingham was punctual, though the intermediate running north of Blisworth was of a more ordinary character.

The L.M.S. have decided wherever possible to use pre-cast reinforced concrete for all bridge reconstruction work. It is much stronger and more durable than timber, which is now regarded rather as an obsolete material for the purpose, while it requires much less subsequent attention than steel, which must be painted frequently and is liable to considerable corrosion in the variable British climate. Ballast for the roadbed over bridges settles well on

concrete, while the cost is usually less, as the units can be manufactured in the company's own depot and conveyed to the site as required for fixing together. The main reinforcement is hard steel wire. Adam Viaduct, between Liverpool and Manchester, not far from Wigan, hitherto largely of timber construction, has been rebuilt as a pre-cast concrete structure.

The relaying of all tracks within 240 yds. of St. Pancras terminus, London, was completed on 7th September last. Over 40 sets of points and 50 crossings were replaced, with large-scale signal modernisation as well as repairs to arches carrying the main lines over the L.M.S. stables. It was necessary to close the station for various periods during six week-ends.

Modernisation work is in hand at Lime Street terminus, Liverpool, where traffic operation has long been restricted by short platforms as well as by a long rising gradient through tunnel or walled cutting just outside. Five of the 11 platforms are now being lengthened. Another big task is the provision of a new signal box with a 95-lever power frame for controlling all points and signals within the station area.

The station at Marsh Lane and Strand Road on the electrified Liverpool-Southport route was destroyed by fire some time ago. It has been replaced by a prefabricated structure of light welded steel on a concrete plinth. The walls of light steel sections are faced with vitreous enamelled iron in light cream.

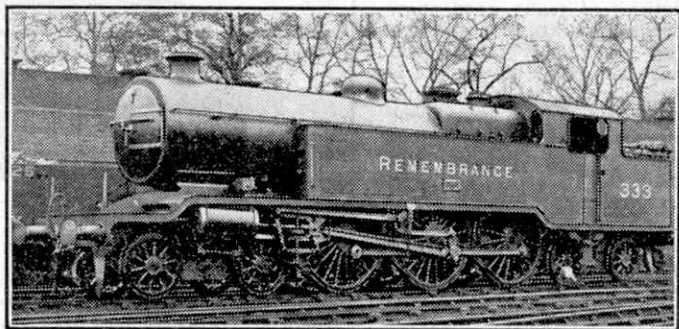

S.R. "Remembrance," in its original form as a 4-6-4T with its L.B.S.C.R. number 333.



L.M.S. 4-6-2 No. 6248 "City of Leeds" at the head of the Royal Train passing Headstone Lane on a run from Wemyss Bay to Euston. Photograph by C. R. L. Coles.

### L.N.E.R. Running Notes

"Pacific" engines from York, Heaton and Gateshead sheds began regular working to London with certain expresses upon the introduction of the winter service last October. Engines stationed at King's Cross also work through to York and Leeds.

Engines recently noted painted green, apart from 4-6-2s and "B1" 4-6-0s include "V3" 2-6-2T No. 7684; 4-4-0s "D11" No. 2681, "Captain Craiggett" and "D29" No. 2411, "Lady of Avenel," both in Scotland, and "V2" 2-6-2 No. 883 of Gateshead.

A reader's report from Middlesbrough indicates that the "A5" and "A8" 4-6-2Ts share with the powerful Gresley 2-6-2T type the haulage of most of the local passenger trains in that area. The stout little "G5" N.E.R. 0-4-4T locomotives are still in evidence, as are the old "D20" 4-4-0 tender engines, a modern touch being provided by the now ubiquitous new standard 4-6-0s, the latest of which at the time of writing are numbered 123x, and by representatives of the "J39" 0-6-0 class. Former N.E.R. freight engines with the 0-8-0 and 0-6-0 wheel arrangements continue to do useful work on Tees-side.

The last 0-6-4T, No. 9082, originally built for the Lancashire, Derbyshire and East Coast Railway, a small system merged into the Great Central, has been withdrawn. These engines were L.N.E.R. class "M1," with 4 ft. 9 in. driving wheels.

The first "L3" G.C.R. 2-6-4T to be broken up is No. 9063. An inroad also has been made into the "J1" G.N.R. 0-6-0 mixed traffic class, as No. 5000 is listed as withdrawn. These engines were notable in their time, with 5 ft. 8 in. wheels capable of considerable speeds on passenger work but not superheated. No. 5000 was the last G.N.R. No. 1, built 1908, becoming L.N.E.R. No. 3001, then lately No. 5000.

The Bo-Bo electric locomotive No. 6000 completed during the recent war as the prototype for operating the Manchester-Sheffield main line passenger or fast freight trains when electrification is completed, was taken over to Holland in the L.N.E.R. vessel "Essex Ferry" in order to engage in extensive trials on the Netherlands Railways, where electric and diesel-electric locomotive traction are being developed on a considerable scale.

### Southern Tidings.

Light 4-6-2 locomotives reported up to October last as running with "Battle of Britain" names, after naming ceremonies in several cases were: 21C 151, "Winston Churchill," 152, "Lord Dowding," 153, "Sir Keith Park," 154, "Lord Beaverbrook," 155 "Fighter Pilot," 164 "Fighter Command," 165, "Hurricane," 166, "Spitfire," 167 "Tangmere." The two last named are allocated to Ramsgate. Others are being added.

"Atlantic" No. 2039 of the "H1" or first L.B.S.C. series has been fitted at Brighton with a new type of valve and modified front end. "Lord Nelson" class

engines have been working through to Oxford, G.W.R.

At least eleven of the Maunsell "Q" class 0-6-0s now have Lemaitre multiple-jet blast pipe with large chimney. Several 4-4-0 and 2-6-0 engines have been fitted to burn oil fuel, for the pumping of which at Eastleigh two "D1" 0-4-2Ts, Nos. 2284, 2361, have been equipped with special gear.

The last express tank built at Brighton before the formation of the Southern Railway, in 1922, was the fine 4-6-4 No. 333. This completed a series of seven begun in 1914, and was named "Remembrance," for it carried bronze plaques in memory of the L.B.S.C.R. men who fell in action during the first world war. The plaques were placed on the tank sides as shown in our illustration. In 1935, in common with the rest of the Brighton "L" class, 2,000 having been added to the numbers, "Remembrance" was converted to a "N15x" 4-6-0 tender engine as depicted in Mr. Coles' photograph, which we also reproduce to show the interesting contrast between original and later appearance.

The centenary of Ashford Works, mechanical headquarters since 1847 of the South Eastern Railway and later the South Eastern and Chatham system, was celebrated recently by the S.R., into whose possession the Works passed on grouping in 1923. There was an exhibition of photographs, paintings and drawings showing Ashford built or operated engines and rolling stock of many ages. In addition there was a display of models made by members of the staff or loaned for the occasion. Visitors saw all the activities in the shops. They also inspected a new "Battle of Britain" 4-6-2, a veteran Stirling 4-4-0 of 1898 just withdrawn and one of the latest corridor carriages.

### Centenary of the Trent Valley Railway—

(Continued from page 471)

most interesting connection, however, is the "phantom" one, about half a mile long, which may be seen on the up side of the main line just South of Tamworth, extending over an embankment and bridge towards the Derby-Birmingham section of the former Midland Railway, which it was intended to join. This spur dates from the 1860s when the M.R. obtained powers to connect with various L.N.W.R. lines in the Midlands—the former Midland engine-shed, now disused, at the north end of Coventry station, is a little-known relic of the same period—but the Tamworth Curve was never brought into use. A siding connection exists between the two lines, however, North of Tamworth station on the up side.

Although the Trent Valley Railway never operated as a separate entity, the title still survives in the suffix ("Trent Valley") applied to the names of several of the intermediate stations, while its niche in railway history is assured.

# Britain Relights the Seas

By Arthur Gaunt

ALL over the world illuminated ambassadors of British efficiency and enterprise are being revived and modernised, for to the United Kingdom have come contracts for re-equipping the signposts of the seas in places as far apart as New Zealand, Norway, China, the Mediterranean and the Arctic. In short, the skill of Britain's lighthouse engineers is universally recognised, and they are being given the job of repairing

bring this vital maritime service back to normal, so that world shipping may once again be adequately warned of the danger spots which menace its routes.

Greece has placed considerable orders in Britain for acetylene-burning beacons; similar equipment is being produced for Iceland; India envisages the replacing of all her oil-burning lighthouses with electrical installations; and Norway, where the coastal beacons suffered particularly extensive damage during the Nazi occupation, is being supplied with new, improved apparatus.

Two of the many new installations are those for the Ytterøerne Lighthouse, on Norway's west coast, and for Pulau Angsa Point, overlooking the Malacca Straits, between the Malay Peninsula and Sumatra. A 4,000,000 candle-power light, visible at a distance of 40 miles, was called for by Norway. British engineers have not only met this requirement, but state that 10,000,000 candle-power lighthouses can be provided, if necessary. At Pulau Angsa Point a complete new lighthouse is being built to carry a 300,000 c.p. light with a range of about 20 miles, and here as at many other places new ideas are being introduced.

Complete reliability is the aim of Britain's designers, and it has now been virtually achieved. For many of the new installations they are supplying automatic devices which immediately rectify any fault. If a lamp burns out it is automatically replaced, and if the current fails there is a stand-by dynamo or storage battery to take over the job. Even oil-burning or gas-lighted beacons can now be fitted with a robot gadget that changes the mantle without attention from the lighthouse keeper. Indeed, fully automatic beacons are now being built that can be left unattended for as long as 12 months. Lights of this type are being made for the Arctic and elsewhere.

The need for skilled, continuous attention



Flamborough Head Lighthouse. There are more than 100 beacons round the shores of Britain.

the damage and destruction which the ocean beacons suffered during the war.

Much damage arose between 1939 and 1945 as a result of neglect and "enemy action." Both in Europe and in the Far East many lighthouses were wilfully put out of commission. Some were completely razed, or had their lighting installations replaced with more sinister equipment. Now strenuous efforts are being made to

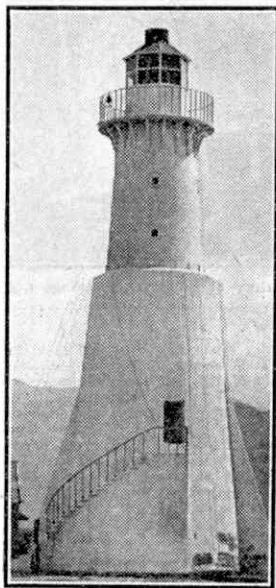

Plum Point Lighthouse, Jamaica.

has been so far overcome that unskilled native staffs can be put in charge of lighthouses in the Far East. The Malacca Straits beacon will be looked after in this way. Sun-operated switches augment the time-clocks to turn on the light at dusk and extinguish it at dawn. They come into action also if weather

demand that the lamp be lit at other times.

Many of the lighthouses and lightships round the shores of the United Kingdom, 100 in number, are scheduled for conversion to automatic equipment or have already undergone this improvement. During recent months engineers and electricians have been busy modernising St. Catherine's Lighthouse, Fowey, Cornwall. The scheme has included the provision of electrical apparatus in place of coal gas light. The new installation includes a solar compensating switch, an automatic lamp changer, and stand-by batteries.

Early this year the Mersey Bar Lightship was brought up to date. The petroleum-vapour illuminant was removed and electrical equipment was substituted. A further improvement was the mounting of the optical apparatus on a constant-level arrangement. This means that the level of the light now remains unchanged, no matter how much the vessel rolls.

Lighthouse building and equipping, indeed, have progressed considerably during the last decade, and designers and technicians were not idle during the war. On the contrary, lessons learned under the stress of wartime

conditions are now helping to restore the world's lighthouse services at a speed hitherto impossible.

The war work of Britain's lighthouse factories included the manufacture of beacons for airfields. To facilitate production, new methods were adopted. The huge lenses, for instance, could not be made quickly enough by the old system of grinding the glasses, so plastic lenses were invented that could be pressed out and then built up with several components. The new mass-production process enabled the beacons to be turned out in a much shorter time. To-day this same idea is available for the manufacture of lenses for lighthouses all over the world.

The traditional tower of granite blocks, dovetailed together in the manner invented by Smeaton 200 years ago, remains the general rule for lighthouses on the most exposed sites. But present-day engineers have perfected an alternative steel girder-structure, and a number of important beacons have been built to this design. Portland Point, Jamaica, has a light carried on a 120-ft. tower of steel lattice-work. Riding Rock, in the Bahamas, has its illuminant, operating for 12 months unattended, at the top of a similar but smaller steel structure.

Smeaton's shape of tower for granite lighthouses has been modified during recent years to correct the tendency it was found to have to throw the waves upward, with possible damage to lanterns and fog bells.

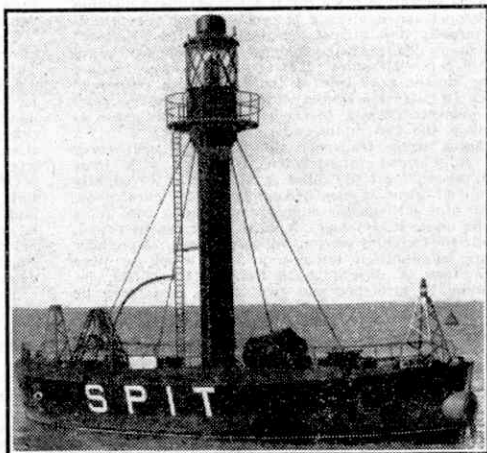

The Spithead Lightship, Rangoon. The two illustrations on this page are reproduced by courtesy of the Gas Accumulator Co. Ltd.



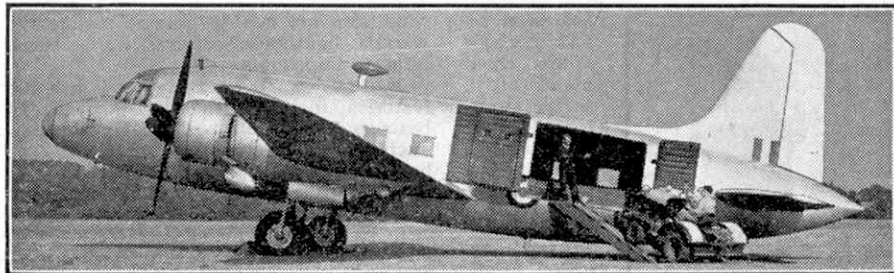

Loading equipment into a Vickers "Valette" transport. Photograph by courtesy of Vickers-Armstrongs Ltd.

## Air News

By John W. R. Taylor

Radlett 1947

Early in September last the eyes of the aeronautical world were centred on the airfield at Radlett, Hertfordshire, where the Society of British Aircraft Constructors held their annual flying display and exhibition. Many aircraft were on show for the first time, and in the next few months I will describe the more interesting of these in "Air News." They provide further proof that British designers, who gave the wartime Royal Air Force the finest fighters and bombers in the world, have lost none of their skill in peacetime.

### Air Transports

Seven of our latest large passenger-transporters were shown, including the "Hermes" II, "Tudor" VII, "Viking," "Marathon," "Ambassador," "Valette" and "Hastings." The first four have already been described in the "M.M.," while the "Valette" and "Hastings" are, respectively, military versions of the "Viking" and "Hermes."

### Vickers "Valette"

This aircraft is to be the R.A.F.'s standard medium transport and is already in production at Weybridge. Externally it is almost identical with the "Viking," the major changes being the provision of more powerful 2,000 h.p. "Hercules" 230 engines, a large loading door in the port side of the fuselage, a reinforced floor to cater for concentrated loads of freight, and an enlarged cockpit to accommodate a navigator as well as the two pilots and radio operator.

As a troop transport the "Valette" will carry 36 fully-armed infantrymen, complete with their equipment, for 1,460 miles at 211 m.p.h. In slightly modified form it can accommodate 20 paratroops, with nine jettisonable supply and weapon containers slung under its fuselage. A large glider can be towed, while the freighter version will carry Jeeps, 25-pounder guns, ammunition tenders, a 3-ton truck or over four tons of miscellaneous freight. Casualties, including 20 stretcher and two sitting cases, can be evacuated with their nurses.

### Handley Page "Hastings"

This is the R.A.F.'s standard heavy transport and will, in brief, do all that the "Valette" will do on a correspondingly bigger scale. Together they form the finest military transport team in the world. The "Hastings" is powered by four 1,675 h.p. "Hercules" 101 engines and can carry up to 50 troops for 2,000 miles at 212 m.p.h. Like the "Valette" it has a large freight-loading door, and can also carry supply containers or even Jeeps externally under its fuselage.

### Airspeed "Ambassador"

This is undoubtedly one of the most beautiful aircraft ever built. It is in the same money-making class as the American Martin 202 and will carry up to 40 passengers for 1,000 miles at 255 m.p.h. The idea behind the "Ambassador" is that a high cruising speed can be obtained by purity of design without any loss in operating economy or safety characteristics. And it has certainly worked out that way, for the aircraft exceeds the proposed I.C.A.O. safety requirements for single-engined performance, although they will not come into force for several years.

The "Ambassador" has two 2,600 h.p. "Centaurus" engines at the moment, although the possibility of fitting projects is being considered. Apart from aerodynamic advantages, its high-wing arrangement facilitates passenger entry and servicing, as it brings the fuselage close to the ground; it also ensures a good downward view from every seat. Test pilots have described the "Ambassador's" handling characteristics in most glowing terms. Having watched it flying gracefully and almost silently across the aerodrome at Radlett, I can only add that it is my dream of an air liner come true.

### Heston A2/45 Air Observation Post

A complete contrast to the giant, streamlined air liners was provided by the Heston A2/45, the first specialised Air Observation Post machine built in this country. It has been designed to supersede the little "Austers" which put in such yeoman service "spotting" for our artillery during the war.

The first essential for an A.O.P. is, of course, an all-round field of view, particularly from air to ground. To achieve this, the designer of the A2/45 has adopted a twin-boomed "pusher" layout, enabling the cockpits to be placed ahead of the low wing. The fuselage nacelle has been kept narrow, while the transparent cabin hood bulges outward. As a result, very little that happens in the air or on the ground is hidden from the crew by any part of the aeroplane.

Of robust, all-metal construction the A2/45 is fully slotted and flapped to ensure a quick take-off and a slow landing, while its tricycle undercarriage is designed to permit operation from small, rough fields. Durability and ease of maintenance are essential requirements and the aircraft can be quickly dismantled for transport by road.

The pusher-type installation of the 240 h.p. "Gipsy Queen" engine presented a number of cooling problems, but these have been solved and the A2/45 is undoubtedly a very useful machine.

### Speed-up in B.O.A.C.'s Ceylon Service

Daily B.O.A.C. *Speedbird* services are now being operated between London and Karachi with Avro "York" aircraft. They supersede the "Haltons" previously used on this route and on the service to Ceylon. As a result, the time taken for the Karachi run is now about 1½ days and the time to Colombo has been reduced by 24 hrs. to 2½ days.



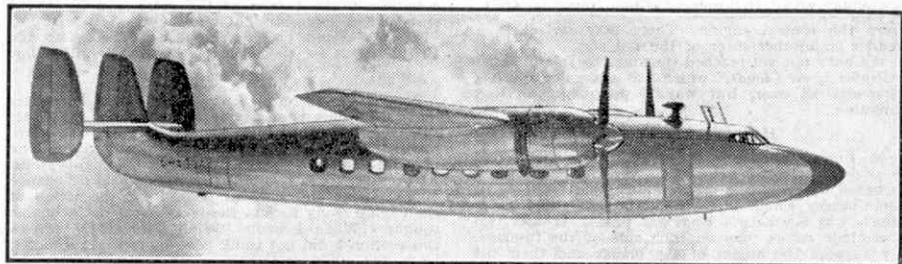

The sleek lines of the Airspeed "Ambassador" are well shown in this flying view, which is reproduced by courtesy of Airspeed Ltd.

#### Automatic Flight

On 22nd September last a Douglas C-54 "Skymaster" of the U.S. Army All-weather Flying Centre took off from Stephenville, Newfoundland, flew 2,400 miles across the Atlantic and landed at the R.A.F. Station at Brize Norton, Oxfordshire, controlled throughout by radio. A crew of nine and five official observers were on board the plane, but they did not touch any of the controls from the moment the aircraft was taxied to the end of the runway for take-off until it had been safely landed by radio control at Brize Norton. Subsequently the aircraft was flown back to America by radio control.

A special article on this important development in aeronautical progress will appear in an early issue.

#### American Indians Honour the R.A.F.

An unusual event took place during the recent brief visit of the R.A.F. Empire Air Navigation school's "Lincoln" "Aries II" to the U.S.A. While at the U.S.A.F. station at Rapid City, South Dakota, in the heart of the Sioux country, the Commandant of the School, Air Commodore N. H. D'Aeth, was invited to become a member of the Sioux tribe. The ceremony took place in the Sioux reservation, and was conducted by the 97-year-old chief, Black Elk, who spoke throughout in his own language. His speech was translated by his son, Crazy Buffalo.

The Chief said that his tribe of some 48,000 Indians had watched with admiration the brave conduct of the British people during their ordeal in the Battle of Britain. The Sioux were a fighting tribe and admired a brave people. The crew of "Aries II" were the first fighting Englishmen whom they had been able to meet, and as a mark of their admiration of the British people as a whole he wished to welcome Air Commodore D'Aeth as a member of the Sioux tribe. The British people could only have stood up to their ordeal if they had possessed brave hearts, and therefore he named Air Commodore D'Aeth "Shanti Oheti-Ka," meaning "Brave Heart."

The ceremony concluded with the presentation of

the traditional feathered headdress, prayers to the four great gods and a ceremonial dance.

#### New York—London Non-Stop

Pan American World Airways now operate a daily non-stop commercial air service between New York and London. The 14-hr. 3,527-mile trip has been made possible by the introduction into service of four new-type Lockheed "Constellation" Clippers, each powered by four 2,500 h.p. Wright "Cyclone" engines. Each of these aircraft accommodates up to 37 passengers in an air-conditioned "floating" cabin and can cruise for short distances at up to 328 m.p.h.

#### British Helicopter Plans

A new British company—Irvin-Bell Helicopter Sales Ltd.—has been formed to handle the sale of Bell helicopters in the United Kingdom. Its Managing Director is Leslie Irvin of the well-known Irving Air Chute Company. Irvin-Bell are setting up a training school for pilots and mechanics at Prestwick in Scotland, and will be responsible for the servicing of all Bell helicopters in this country. One Bell Model 47B has been delivered and several demonstrations have already been given. Future deliveries will consist chiefly of the new Bell utility-type helicopter, specially designed for agricultural and air mail use.

Firth Helicopters Ltd., of London, have obtained the licence to manufacture in Britain helicopters based on designs and patents held by the American Landgraf Company. The results should be good, for Firth metal products are known all over the world, while the Landgraf H-2 experimental single-seat helicopter is one of the most promising rotary-wing aircraft flying to-day. It is a tiny machine with a loaded weight of only 850 lb., and its two intermeshing rotors are driven by a very old British Pobjoy engine, developing only 85 h.p., which was the only motor that Mr. Landgraf could afford at the time. But it has proved exceptionally stable and easy to control. Firth and Landgraf are now engaged in a friendly competition to see who can place the first commercial helicopter on the market.

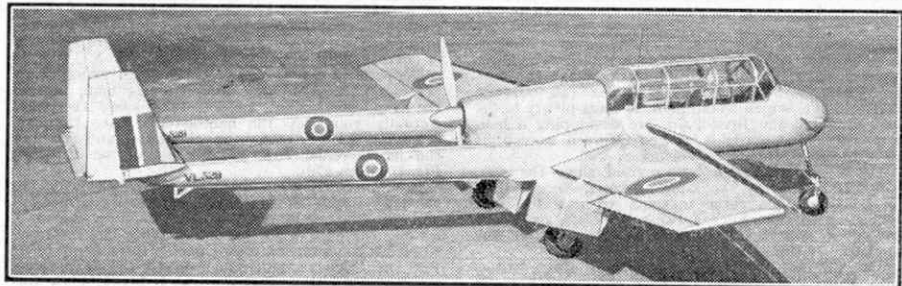

The Heston "Air Observation Post." Photograph "The Aeroplane" copyright.

**Something about Helicopters**—(Cont. from page 468)

from the central engine. There may be either a rudder or another rotor at the tail end.

We have not yet reached the stage of Jules Verne's "Clipper of the Clouds," which was a mass of whirling airscrews all over, but we are progressing in that direction.

**Helicopters of To-day**

In Europe about the only helicopter which had done practical work before 1939 was the Focke-Wulf, designed by Dr. Focke of Hamburg, and built in the same works which later built the FW 190 fighter which was Germany's best war plane. It had two four-blade rotors, one on each side of the fuselage. By varying the angles of the blades and their tilt the pilot could make it fly backward, sideways or any way. But it did not autorotate if the engine stopped. Dr. Focke is now building them in France for the French Government.

In the U.S.A., Igor Sikorsky, who built a four-engined biplane for the Czar's Army in 1913-14, and became a refugee from the Bolsheviks in 1917, and has been building aircraft in the U.S.A. ever since, built a helicopter in 1942. It has been much publicised. One picture of it showed about 14 people festooned on and round it, some 10 or 12 feet off the ground. If the engine had stopped there would have been a mess, as it could not autogyrate. I believe that it had a mechanical control by which the pilot could change the blades from the driven position to autorotation in a few seconds, but it needed a drop of 50 feet or so before the new position took effect—which made a long danger-zone. Sikorsky is now a subsidiary of the United Aircraft Corporation. His types vary between 175 h.p. and 450 h.p.

Wallace Kellett, who had been building Autogiros in the U.S.A., turned over to helicopters in 1943. He and his men designed a machine of 245 h.p. in which two rotors, with three blades each, are mounted on two shafts so close together that the blades intermesh, like cogwheels, but run in opposite directions. It is most ingenious, and seems to me the most promising type of all, when once, as I have quoted him, he has the engineering job whacked as well as the aerodynamics. A French firm is working on the same idea.

Larry Bell, of the Bell Aircraft Corp., who built the Airocra and sundry fighters and jet machines, recently produced the Bell 47, or U.S. Army YR 13, helicopter of 175 h.p. It is the only type I know which has a two-blade rotor. Below it is a metal arm which has a balance-weight at each end, the object of which is to "damp out" or cushion, the vibration of the two blades. As I have said, the European rights have been taken over by Leslie Irvin of parachute fame, in conjunction with Scottish Aviation Ltd. of Prestwick.

The great Firestone Tire and Rubber Co. of Akron started in 1943 a subsidiary firm called the Firestone Aircraft Co. It has acquired some hundreds of patents on rotary-wing aircraft, which shows what Big Business in the U.S.A. thinks of the air-bus of the future. The firm's experimental machines have an ordinary three-blade single rotor, and an engine of only 135 h.p.

The Landgraf Helicopter Co. is building a streamlined variant of the Focke-Wulf with a three-blade rotor on each side of an ordinary aeroplane fuselage. They use an 85 h.p. Pobjoy engine (an obsolete British make) which would seem to have plenty to do.

In England the Bristol Co. are developing a helicopter designed by Hafner, who between wars built an autorotating machine which flew well.

The Cierva Autogiro Co., revised since the war, and still backed by the Weir interests, have built a three-blade single rotor machine with a 200 h.p. engine. Also they have a two-rotor craft, on Focke lines, but with a third rotor on the stern of the fuselage. It sounds interesting.

The Fairey Co. have a three-blade single rotor, with a little stub wing on each side, and a small airscrew on the tip of the right hand stub, which

counteracts the torque of the rotor and helps the speed when going straight ahead.

The Westland Co. of Yeovil have taken up the British rights for the Sikorsky, and that is all so far.

**To Wind Up**

So you see there is plenty doing in the helicopter line. But there is plenty to be done. No helicopter can be called safe till it changes instantly and automatically from lifting, which includes hovering in one place at one level, to autorotating if the engine stops. At present the pilot sits with one hand on a "change angle" lever, and one ear cocked for the sound of the engine ready to jam the lever down if the engine coughs. (When I wrote "Wind Up" at the top of this section I did not think how appropriate it would be in the aviator's sense).

He knows that the rotor blades are held out straight, to carry the load, by centrifugal force—that is the force that holds a string straight if you whirl a weight round at the end of it, or the force which keeps the water in a bucket if you whirl it round horizontally. If the speed of the rotors drops and the centrifugal force dies, then the blades will fold up like the ribs of an umbrella blown inside out. And then nothing can save a crash.

Moreover, with all that tackle, or top-hammer, overhead there is no chance of using a parachute. One bright brain suggested carrying a parachute inside the hollow shaft of the rotor and shooting it out when in trouble and so saving the whole machine—one would need a mighty big parachute.

When once we have got automatic autorotation then we shall be well on the road to regular helicopter services. Reliability becomes purely a matter of engineering, just as it was with motor cars between 1890 and 1910. We don't think to-day of wheels coming off or axles breaking. Similarly, ten or more years hence we shall not think of rotor-blades breaking or rotor-shafts seizing up and jamming, or of bearings breaking up.

In those happy days our "helitaxis" or "helibusses" will take us safely to and from airports at which the aeroplanes start and arrive on time, better than railway trains, and fly in any weather, and land slowly and not burn up.

**Puzzle Your Sharp-Eyed Friends**—

(Continued from page 476)

sure enough, the design is now printed on its white surface and the tray is quite blank.

**The Secret.** There are two handkerchiefs, or squares of white material, both alike except that one has a simple design painted on it, or embroidered on it if you have any spare sisters who can be persuaded to waggle a useful needle. The handkerchief with the design is folded so that the design doesn't show. It is then hung over the front edge of a hat standing on a table. This table also has a sheet of newspaper on it. The tray, propped up on edge to show the design, rests against the hat, hiding the handkerchief.

The tray is really quite blank. The design, a duplicate of the one on the handkerchief, is painted on a square of card the same size and colour as the tray. This card lies on the tray and the design appears to be on the tray itself. The reverse side of the card is covered with newspaper.

To perform the trick, show the plain white handkerchief first. Fold it and apparently hang it over the edge of the hat as you take away the tray. Actually you drop the handkerchief into the hat, removing the tray with your other hand, and exposing the handkerchief that has the design on it. (See Fig. 10, page 476).

Now draw attention to the design on the tray, lay the tray upside down on the newspaper while you pick up the handkerchief again. Pick up the tray, leaving the card with the design lying on the table, where its newspaper-covered back will camouflage it. Put the folded handkerchief on to the tray for a moment, then show that the tray is blank, shake out the handkerchief and reveal the design.



# Club and Branch News



## WITH THE SECRETARY

### A MERRY CHRISTMAS

The coming of the Christmas season brings with it thoughts of the good will that is the outstanding character of the Meccano Guild and of Meccano Club life. It is at Christmas that the true comradeship of Club members finds its most exuberant expression, for in practically every Club some celebration of the

## CLUB NOTES

**TRANMERE M.C.**—Model-building contests are very popular with members of this newly affiliated Club, and attract splendid entries. A Lecture on "Hornby Trains" was given by Mr. K. Robertson. A Club Library has been formed. Club roll: 8. *Secretary:* D. Nayboar, 53, Milton Road, Birkenhead.

**HENLEAZE M.C.**—The Club's Garden Exhibition attracted more than 70 visitors, who were greatly

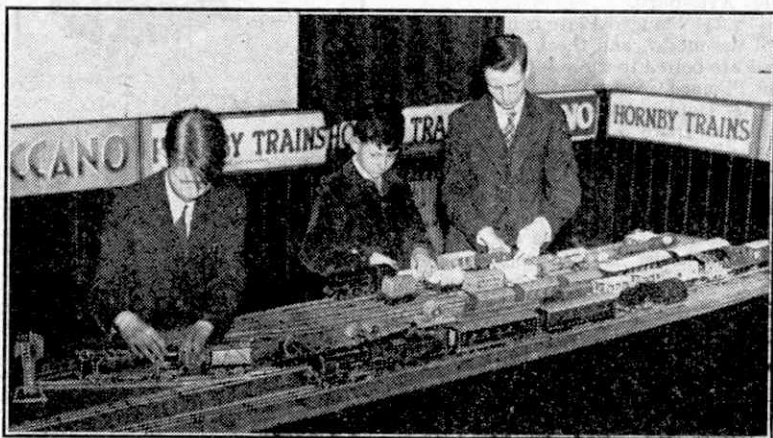

A Norbury M.C. group at a recent Exhibition, with D. R. C. Pavey, the former Secretary, on the right. This Club was incorporated in December 1935 as the St. Oswald's (Thornton Heath) M.C., and the present name was adopted in March of this year. The President is Mr. W. J. Wyse, B.Sc., Mr. C. B. Chapman is now Leader, and P. Knight has become Secretary. The Exhibition attracted more than 350 visitors, who showed the greatest interest in the Meccano Models displayed, and in the Film display and other sideshows. Photograph by courtesy of the "Croydon Times."

season is arranged, and in many cases parents and friends of members are rightly invited to share in the good time that is arranged.

There is every reason for enjoying a Christmas party this year, in spite of the difficulties of the times, for the movement is making remarkable progress. During 1947 the number of members has increased at a very satisfactory rate, which at times became almost alarming, severely straining the capabilities of the members of my staff who despatch badges and certificates to new members. The pace has not been quite as swift in the Clubs, but this is only to be expected. Recovery from the severe conditions of wartime has not been easy, and in particular the difficulty of finding accommodation has prevented the formation of many good new Clubs.

Excellent efforts are now being made to form Clubs where they are not at present in being, and I want every Guild member who has not already become connected with a Club to do all that he can to help. If there is no Club within easy reach of any member he should try to form one. Those who do not take an active share in Club life miss much of the fun of their hobby.

In the October "M.M." I included the name of Mr. B. Waters, Portsmouth, in the list of "Proposed Clubs." This Club is not an open one; membership is restricted to boys attending Portsmouth Grammar School

interested by the Eiffel Tower, Logging Tractor and other models on view. A Hornby Railway also was in operation. A permanent outdoor layout is under construction. Club roll: 15. *Secretary:* M. E. Frost, 32, Oakwood Road, Henleaze, Bristol.

### AUSTRALIA

**THEBARTON BOYS' TECHNICAL SCHOOL M.C.**—Many excellent models of a scientific character have been constructed, and in addition splendid Talks have been given by Mr. E. S. H. Gibson, Leader, on glass blowing, the theory of wheels and electric clock construction. Films also have been shown, Talks have been given by members and Visits have been paid to the Thebarton Fire Station and various Works. Club roll: 42. *Secretary:* Mr. A. Wallis, Thebarton Boys' Technical School, Ashley Street, Thebarton, South Australia.

### BRANCH NEWS

**BRISTOL RAILWAY CIRCLE (JUNIOR SECTION)**—Regular Track Nights have been held, and other events on the programme have included visits to places of railway interest, including the 15-in. Gauge Railway at Hardwick Manor, by kind invitation of Mr. R. D. Barnett Clayton, Vice-President. The Gloucester Railway Carriage and Wagon Company's Works also have been visited. *Secretary:* P. R. Clair, 22, Westfield Park, Bristol 6.

# Among the Model-Builders

By "Spanner"

## An Intermittent Motion Mechanism

Fig. 1 shows a model intermittent motion, based on the escapement of an old clock seen in a London shop. It was submitted by Mr. R. H. Warwick, Little Kimble, Aylesbury.

A  $5\frac{1}{2} \times 2\frac{1}{2}$ " Flanged Plate is used for the base of the model, and the Flanged Sector Plates 1 are bolted to the sides of this. Two further Flanged Sector Plates are attached to  $4\frac{1}{2} \times \frac{1}{2}$ " Double Angle Strips 2. A  $2\frac{1}{2} \times 1\frac{1}{2}$ " Flanged Plate 3 is bolted in position across the Sector Plates 1. Two  $2\frac{1}{2}$ " Strips 4 are attached to the Plate 3, and each is fitted with a Crank that supports the Rods 5.

The winding drum for the Cord is formed by a Wood Roller held on a  $6\frac{1}{2}$ " Rod by two Bush Wheels. A 1" Sprocket Wheel locked on the same Rod is connected by Sprocket Chain to a  $\frac{3}{4}$ " Sprocket on the Rod 6. A  $\frac{3}{8}$ " Bevel Gear 7 meshes with a similar Gear on the Rod 8. This Rod is journaled in the Flanged Plate 3, and a  $2\frac{1}{2} \times \frac{1}{2}$ " Double Angle Strip 9. The upper end of Rod 8 carries a Double Arm Crank fitted with a  $5\frac{1}{2}$ " Strip. The bob weight is a Worm suspended from a length of Cord tied to a Fishplate bolted to the end of the  $5\frac{1}{2}$ " Strip.

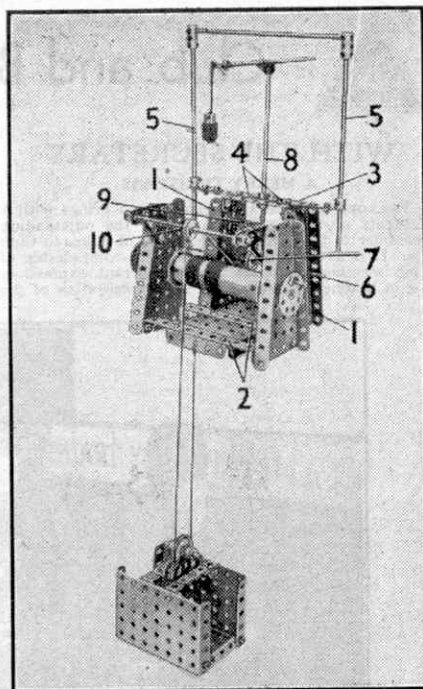

Fig. 1. An intermittent motion mechanism based on the escapement of an old clock.

Cord is fastened to the Wood Roller, passed over a  $\frac{1}{2}$ " loose Pulley 10, and around a 1" Pulley attached to a suitable weight carrier and then tied to the Flanged Plate.

As the Wood Roller rotates under the influence of the suspended weight, the action is transmitted by the Sprockets and Gears to the Rod 8. Movement of this Rod causes the bob weight to fly outwards until it is checked by one of the Rods 5. The bob weight makes several turns around this Rod and then unwinds, allowing Rod 8 to move another half turn.

This movement is quite accurate, but very careful adjustment would be required before it could be incorporated in a clock. However, it can be used as a counting device, and amateur photographers will find it useful for timing printing exposures and developing operations.

## A Crane Winding Mechanism

Cranes of all types make excellent subjects for Meccano models, and the

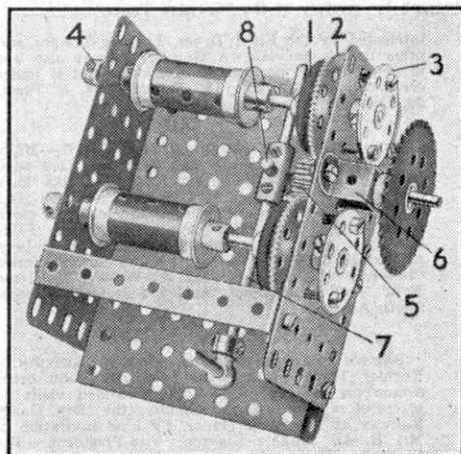

Fig. 2. Winding mechanism suitable for a model crane.



interest and realism of such models is greatly increased when a Clockwork or Electric Motor is incorporated in them. The mechanism shown in Fig. 2 is particularly interesting as one lever only is used to control the jib and pulley block movements, and a brake is automatically applied to each drum when it is not actually driving.

The drive to each winding drum is transmitted through a friction clutch, which also acts as an effective overload release, as it will slip under the effect of a load in excess of the crane's lifting power.

Each winding shaft is fitted with a drum built up from a Sleeve Piece and  $\frac{3}{4}$ " Flanged Wheels, a 1" Pulley 1, a 57-teeth Gear 2 and a Bush Wheel 3. The Pulley 1 and Bush Wheel 3 are locked on the Rod, but the Gear 2 is free to turn. Normally the Pulley 1 is held out of engagement with the Gear by the action of a Compression Spring fitted beneath the Collar 4 and the housing side-plate. The Bush Wheel is fitted with two  $\frac{3}{8}$ " Bolts, which engage in the holes of the sideplate when the clutch is disengaged, thus preventing the winding drum from rotating.

The drive to the 57-teeth Gear is taken from a  $\frac{1}{2}$ " Pinion 5. This is locked on a 2" Rod mounted in the mechanism side-plate and in a Double Bent Strip 6.

The 1" Pulleys can be forced against the 57-teeth Gears by means of a lever 7. This lever consists of a  $1\frac{1}{2}$ " and a  $2\frac{1}{2}$ " Rod held in a Coupling. The Coupling is pivoted on a  $1\frac{1}{2}$ " Rod 8, which is supported by a second Coupling attached to the Flanged Plate by two Bolts.

### A Ratchet Brake Lever

In many models it is convenient to have a brake lever that can be held in any position within the limit of its movement, and usually a ratchet mechanism is employed for this purpose. The device

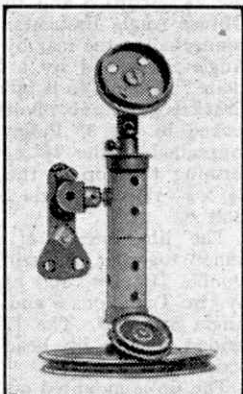

A "simplicity" telephone set by R. W. Kett, Melbourne, Australia.

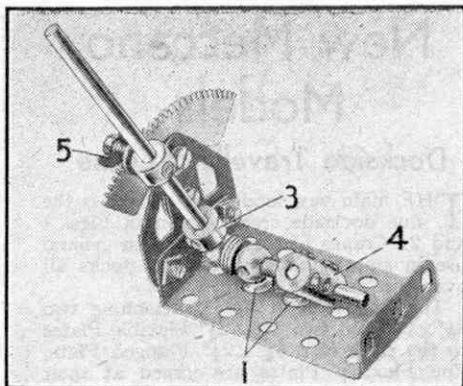

Fig. 3. A useful ratchet brake lever.

shown in Fig. 3 will be found useful and efficient.

The base consists of a  $2\frac{1}{2}$ " x  $1\frac{1}{2}$ " Flanged Plate fitted with two Handrail Supports 1. A 2" Rod mounted in the Handrail Supports carries a Handrail Coupling 3 and a Coupling 4. The brake lever consists of a  $3\frac{1}{4}$ " Rod locked in the Handrail Coupling 3. A Rack Segment is firmly attached to a Flat Trunnion bolted to the base. A Collar on the brake lever is fitted with a  $\frac{3}{8}$ " Bolt and a Spring Clip 5, in such a position that the rounded portion of the Spring Clip bears against the teeth of the Rack Segment. The Coupling 3 is connected to the brake operating rods.

### "SIMPLICITY" COMPETITION BIG PRIZES FOR SMALL MODELS

In this Contest a number of prizes will be awarded to Meccano model-builders who succeed in constructing the most ingenious models with the smallest possible number of parts.

It is of course quite easy to bolt together two or three Strips and a Pulley or two and call the result a crane or a motor car, but such a model is not likely to win a prize in this contest. Competitors should first choose a suitable subject and then build their models with the smallest possible number of parts consistent with a realistic effect. Competitors may use any number or variety of parts that they wish, but the prizes will be awarded to those who succeed in building the most ingenious models from the smallest number of parts.

When the model is completed the competitor should obtain either a photograph or a good drawing of it and then send this to "Simplicity Model-Building Contest, Meccano Ltd., Binns Road, Liverpool 13." The actual model must not be sent. The competitor's age, name and full address must be written on the back of each photograph or drawing submitted for consideration.

Entries will be divided into two Sections as follows: A, for readers of all ages living in the British Isles, B, for Overseas readers of all ages.

January 31st, 1948, is the last day on which entries will be received from competitors living in the British Isles. Overseas readers must forward their entries so that they reach Liverpool not later than 31st May.



# New Meccano Models

## Dockside Travelling Crane

THE main new model this month is the fine dockside crane shown in Figs. 1 and 2. Cranes of this type are in general use in ship-building yards and docks all over the world.

The base is built up by attaching two  $5\frac{1}{2}'' \times 2\frac{1}{2}''$  and two  $2\frac{1}{2}'' \times 2\frac{1}{2}''$  Flexible Plates to the sides of a  $5\frac{1}{2}'' \times 2\frac{1}{2}''$  Flanged Plate. The Flexible Plates are joined at their lower ends by two  $2\frac{1}{2}'' \times \frac{1}{2}''$  Double Angle Strips, and the  $12\frac{1}{2}''$  Angle Girders 2 are then bolted in position. The travelling wheels consist of eight  $1\frac{1}{2}''$  Flanged Wheels, locked in pairs on  $3\frac{1}{2}''$  Rods. These Rods are journaled in  $12\frac{1}{2}''$  Flat Girders attached to the Angle Girders 2.

The mechanism and driver's cab are supported on a tower formed by bolting together two Flanged Sector Plates and two  $4\frac{1}{2}'' \times 2\frac{1}{2}''$  Flexible Plates. A  $2\frac{1}{2}'' \times 1\frac{1}{2}''$  Flanged Plate is then bolted in position across the top. The tower is attached

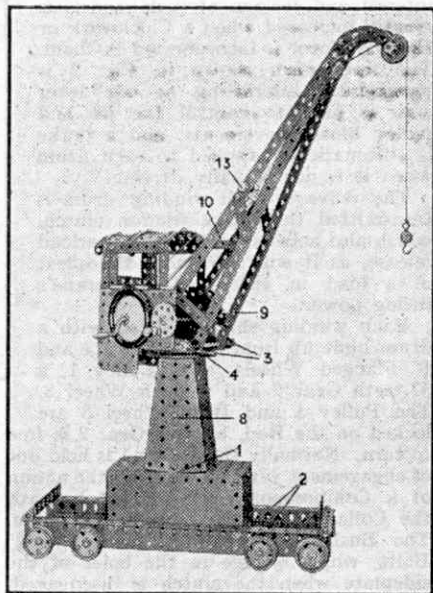

Fig. 1. A dockside crane fitted with luffing and hoisting mechanisms.

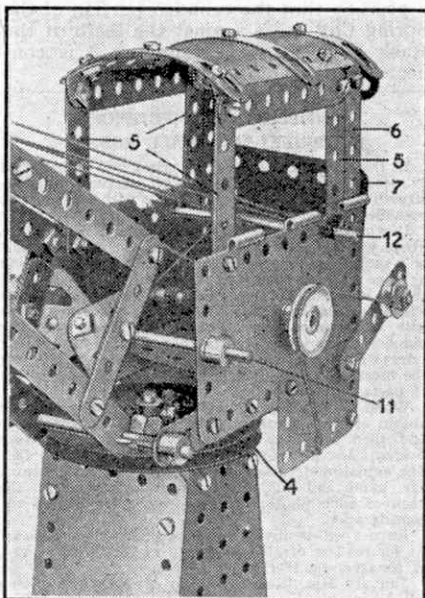

Fig. 2. The cab of the dockside crane.

to the base by means of Fishplates, one of which can be seen at 1.

The cab is made by attaching the  $5\frac{1}{2}''$  Strips 3 to a  $3''$  Pulley Wheel 4 by means of two  $2\frac{1}{2}'' \times \frac{1}{2}''$  Double Angle Strips. Each of the side plates of the cab consists of half of a Hinged Flat Plate bolted to the Strips 3. The roof consists of two Curved Plates fastened together and attached to the  $2\frac{1}{2}''$  Strips 5 and the  $5\frac{1}{2}''$  Strips 6 by Obtuse Angle Brackets. The Strips 3 are connected at the rear by a  $2\frac{1}{2}'' \times \frac{1}{2}''$  Double Angle Strip and by a  $2\frac{1}{2}'' \times 2\frac{1}{2}''$  Flexible Plate 7 fastened to it by means of an Angle Bracket. The cab pivots about a  $4''$  Rod locked in the  $3''$  Pulley 4. This Rod is journaled in the  $2\frac{1}{2}'' \times 1\frac{1}{2}''$  Flanged Plate forming the top of the tower, and in a  $2\frac{1}{2}'' \times \frac{1}{2}''$  Double Angle Strip held by the Bolt 8.

The jib consists of four  $12\frac{1}{2}''$  Strips joined together at their outer ends by a Double Bracket, and at their inner ends by two Trunnions 9 and a  $1\frac{1}{2}'' \times \frac{1}{2}''$  Double Angle Strip 10. The  $12\frac{1}{2}''$  Strips are extended at the jib head by two Curved Strips.

The jib is mounted on a  $3\frac{1}{2}''$  Rod passed through the end holes of the Strips 3 and retained in position by Collars.

Raising and lowering of the load is

controlled by a Crank Handle, which is journalled in the centre holes of the Hinged Plate forming the sides of the cab. A length of Cord fastened to a Cord Anchoring Spring on the Crank Handle passes over a 1" loose Pulley mounted on a 1" Rod in the jib head.

The jib is luffed by means of a  $3\frac{1}{2}$ " Rod 11 fitted with a Bush Wheel. A length of Cord from this Rod passes around Rod 12 and a 2" Rod 13 in the jib. It is passed again around Rods 12 and 13, and finally is tied to Rod 12.

### A Simple Steam Wagon

Our other new model is a simple steam wagon, which can be built from the contents of Outfit No. 2. This is shown in Fig. 3, and is commenced by building the boiler, which is made up from two  $5\frac{1}{2}$ "  $\times$   $1\frac{1}{2}$ " Flexible Plates connected together by Fishplates. A Bush Wheel is used for the end of the boiler and it is fixed in place by Angle Brackets 2. The sides of the cab are  $2\frac{1}{2}$ "  $\times$   $1\frac{1}{2}$ " Flexible Plates bolted to the Plates forming the Boiler. Two  $2\frac{1}{2}$ " Strips are bolted in a vertical position to the Flexible Plates to provide the cab-roof supports. Two  $2\frac{1}{2}$ " Strips are attached to the sides of the cab by the Bolts 1, as shown in the illustration.

Two  $2\frac{1}{2}$ "  $\times$   $2\frac{1}{2}$ " Curved Plates are used for the roof of the cab and they are con-

nected to one of the vertical supports by an Angle Bracket. The rear of the cab, a  $2\frac{1}{2}$ "  $\times$   $2\frac{1}{2}$ " Flexible Plate, is connected to the roof by another Angle Bracket, and two  $2\frac{1}{2}$ " Strips and a  $2\frac{1}{2}$ " Curved Strip are bolted along its edges.

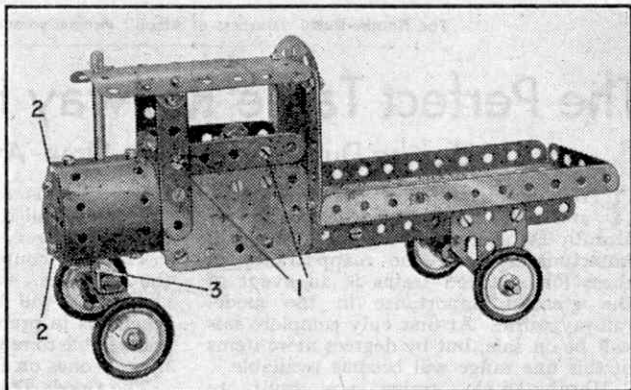

Fig. 3. A realistic steam wagon built from Outfit No. 2.

Four  $5\frac{1}{2}$ " Strips represent the side members of the chassis and they are spaced by two Trunnions bolted together. The fronts of the side-members are bolted along the edges of the  $2\frac{1}{2}$ "  $\times$   $1\frac{1}{2}$ " Flexible Plates forming the sides of the cab. Flat Trunnions support a  $3\frac{1}{2}$ " Rod used as a rear axle, and the body of the wagon is made from a  $5\frac{1}{2}$ "  $\times$   $2\frac{1}{2}$ " Flanged Plate connected to the side-members with Angle Brackets. The front axle, another  $3\frac{1}{2}$ " Rod, is supported in a  $2\frac{1}{2}$ "  $\times$   $1\frac{1}{2}$ " Double Angle Strip, which is pivoted at its centre to a Reversed Angle Bracket 3 bolted underneath the boiler.

## MODEL-BUILDING COMPETITION RESULTS

### "Autumn" Contest (Overseas Section)

The principal prize-winners in the Overseas Section of the "Autumn" Competition, are as follows:

1st, Cheque for £2/2/-: P. B. Henriksen, Pietermaritzburg, Natal, South Africa; 2nd, Cheque for £1/1/-: G. Burns, Victoria, Australia; 3rd, P.O. for 10/6: Pablo Giese, Buenos Aires.

A model battleship, 6 ft. in length and equipped with an amazing amount of beautifully modelled detail work, was successful in winning the First Prize for P. B. Henriksen, Pietermaritzburg. This model is one of the best of its type that I have seen and I congratulate its builder

on his fine achievement.

A young Australian model-builder aged 13 won the Second Prize. He is G. Burns, Victoria, and his model marine engine is a fine piece of work in view of his age.

Our old friend Pablo Giese, Buenos Aires, was awarded Third Prize for a giant lorry and a load consisting of a 2-6-4 type locomotive. This was illustrated on page 411 of the October "M.M." The lorry itself is driven by a 20-volt Electric Motor that actuates the four driving wheels through a gear-box and a differential. The wheels are mounted in pairs on two separate rear axles, and to allow articulated movement of these axles a Sprocket Chain drive is included between the differential and the rear wheels on each side of the model.

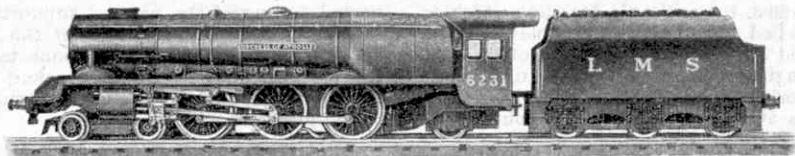

The Hornby-Dublo "Duchess of Atholl" locomotive and tender.

## The Perfect Table Railway Here Again

### Hornby-Dublo Train Sets Now Available

THIS month we have the pleasure of announcing the return of the famous Hornby-Dublo trains. Supplies are small, unfortunately, but the reappearance of these long-awaited trains is an event of the greatest importance in the model railway world. At first only complete sets will be on sale, but by degrees more items of this fine range will become available.

Hornby-Dublo trains are built to standard 00 Gauge, which is approximately half the size of the Hornby 0 Gauge. Hornby-Dublo is the perfect table railway.

The trains run on direct current at 12 volts, derived from alternating current mains. The mains supply passes through a Dublo Transformer, which reduces it to 12 volts. It is still alternating current, however, and it then passes to the rectifier unit included in Dublo Controller No. 1, from which it emerges as direct current at 12 volts. Each train set contains a Dublo Controller No. 1, but a transformer is not included.

The new Dublo trains are fitted with automatic couplings of an improved design which engage immediately when the vehicles are pushed together. It is easy to uncouple them; in fact a coach or a truck can be lifted bodily from the track without disturbing the vehicles to which it is coupled. The greatest advantage of all, however, is that the new couplings will link up with an Uncoupling Rail of special

design that is to be introduced shortly. With this Rail it will be possible to carry out almost every real railway movement.

The new couplings will not work with the old ones. Owners of pre-war Dublo equipment will be glad to know that a scheme is in preparation under which they will be able to replace their pre-war vehicles by new ones on favourable terms.

The Goods Train Set includes the Dublo 0-6-2 Tank Locomotive, a wagon, a goods van and brake van, finished in the styles of each of the four main line groups. This set will be ready this month.

The L.M.S. and the L.N.E.R. Passenger Train Sets are expected to be ready early in the New Year. Of these, the L.M.S. Passenger Set includes the fine "Duchess of Atholl" 4-6-2 locomotive with outside valve gear, the characteristic double chimney and practically every external detail. The two coaches represent L.M.S. standard stock.

The L.N.E.R. 4-6-2 locomotive, "Sir Nigel Gresley," has been renumbered, and the lower side plating of its streamlined casing has been cut away as on the actual engine to reveal the connecting rods and motion. Two separate bogie coaches are now included in this L.N.E.R. set.

Next month we shall describe and illustrate the new Hornby-Dublo trains in detail.

The Hornby-Dublo "Sir Nigel Gresley" and the standard Tank locomotive appear in this illustration.

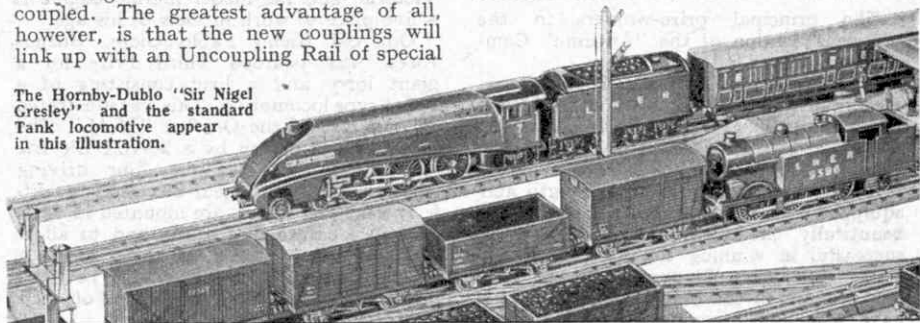

# Fun With Your Hornby Goods Train

THE articles on this page during the last two months have dealt with simple passenger train operations on a plain layout. This month we will consider a few ideas for the benefit of those who are beginning their miniature railway career with a Hornby Goods Train set, or who may have been lucky enough to obtain a set of each kind. The same schemes will interest the owners of passenger train sets who may have acquired one or two goods vehicles, secondhand perhaps or "left-overs" from an elder brother's original layout, and so on. Unfortunately, Hornby rolling stock cannot yet be bought separately.

The idea is that a little experimenting will show the number of turns of the winding key required to enable the engine to make a particular move. We may require to assemble the wagons together. Having done so we may start the train and make one, two or more circuits of the track, coming to rest again at the starting point.

The starting point can be a simple platform such as the box-lid station shown in the October "M.M." On the other hand those with Meccano Outfits can design a suitable goods platform from Meccano Parts like the one in the accompanying illustration. This consists chiefly of Flexible Plates, stiffened by Strips and fastened together with Angle Brackets. The roof of the building consists simply of a Hinged Flat Plate. The simple crane is an attractive feature and enables actual loads to be handled.

We can have a great deal of fun with different loads. After a train has been put together it can be drawn up alongside the goods platform so that each wagon in turn can be loaded. When this part of the job is completed we can give the train a run round, dealing perhaps with the unloading of one wagon at the first stop. Other wagons can be dealt with in turn at subsequent

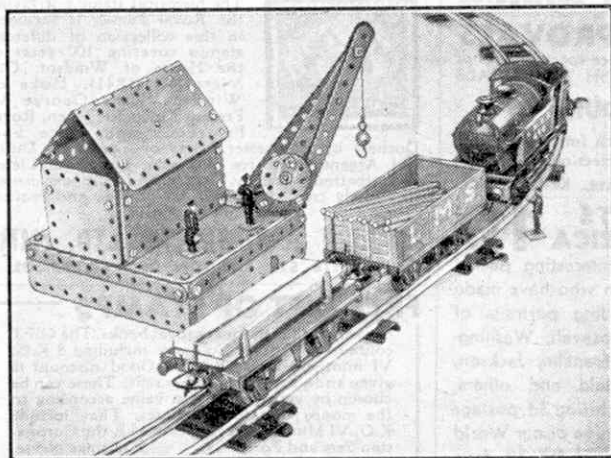

A Hornby Train alongside the simple goods platform constructed from Meccano parts as suggested on this page.

Let us suppose that we have a Hornby No. 201 Tank Goods Train. One feature that we are sure to notice when the rolling stock is placed on the rails is that automatic couplings are fitted. These engage one another when the vehicles are pushed together by the engine. The engine also has an automatic coupling at the bunker end. Thus the complete train can be made up by pushing each wagon in turn against the next but we must keep in mind the injunction, often seen on real wagons, "Shunt with care," or the result may be disappointing.

In general the management of the engine and train will follow similar lines to those indicated in the last two articles. Briefly

stops. Then their individual loads can be changed about and possibly the loading of certain items and the unloading of others can be carried out at the one stop.

Many variations of the same general scheme can be devised. Longer runs can be made at times. The order of the wagons in the train can be changed, and the loads also can be varied. Meccano Parts again come in handy here; in the illustration the Rods shown in the Wagon represent a consignment of tubes or pipes.

Other goods that can be handled at the platform can be imitated in various ways. Empty matchboxes make quite good cases and small cotton bobbins can represent barrels or drums.



## BARGAIN DISCOUNT APPROVALS

Try our BARGAIN DISCOUNT APPROVALS—the REAL Collector's Service, equally good for Sellers and Clubs. Prices 1d.-6d. per stamp and generous discount. Modern and new issues, Br. Col. or B.C. and Foreign, mint and used. G.VI priced each and Book of Sets included. Send with confidence, for we NEVER send again unless you ask. For prompt, personal service and complete satisfaction write NOW to

## THE BIRKDALE STAMP CO. (P.T.S.)

POSTAL BUSINESS ONLY

104, LIVERPOOL ROAD, SOUTHPORT, Lancs.



**FREE TO  
ALL  
COLLECTORS**

(Postage 2½d.)

**NEW ISSUE FOR NORFOLK ISLAND**  
G. P. KEEF, Willington, Eastbourne

## HALF PRICE APPROVALS

We are offering until further notice special books of GREAT BRITAIN and BRITISH COLONIALS

at **50% DISCOUNT**

Minimum purchase, 10/- worth for 5/- net.  
Send stamp for trial selection.

SAUNDERS & CO., 8, Hawthorne Ave., KENTON, Mdx.

## 10 PRESIDENTS OF U.S. AMERICA 10



**FREE!** This interesting packet of famous men who have made history, including portraits of Presidents Roosevelt, Washington, Lincoln, Franklin, Jackson, Adams, Garfield and others. Write now enclosing 3d. postage and ask for this packet and selection of our World Famous Approval Sheets. Offer is for 30 days only, abroad 60 days.

## ERRINGTON & MARTIN

Established 1880

Dept. 454, South Hackney, London E.9, England

5/- post free—1,000 DEALERS' MIXTURE OFF PAPER  
Approximate 1,000 (weighed) UNSORTED mixture  
Foreign and Colonial Stamps. Old and New issues.  
Fine for swaps, Club Sheets, etc., etc. You will be  
pleased, I know. Abroad postage 1/- extra  
JOS. H. GAZE, 10, Pimlico Road, CLITHEROE, Lancs.



## R.A.F. PEACE FREE

This wonderful offer consists of the fine PEACE stamp illustrated, showing 4 famous aeroplanes in honour of the Air Force; also a latest PAKISTAN issue; BURMA K.G.VI; and a scarce S. AFRICA VICTORY stamp. All Free to applicants for my Bargain Discount Approvals and sending 3d. for postage and list of sets. (Without approvals price 8d.)

G. L. WRIGHT, Dept. NP, 29, Palace St., Canterbury, Kent

For other Stamp Advertisements see also pages 498 and xi.

## N.Z. VICTORY STAMPS

A fine unused set of New Zealand Victory stamps showing Lake Mathieson, King Geo. VI and Parliament, and St. Paul's Cathedral with the Union Jack in the background, a quotation from one of Mr. Churchill's great Battle of Britain speeches, and the V sign, designs truly symbolising the sources of Peace, Strength, and Victory, sent free to all applicants for approvals enclosing 2½d. postage.

R. D. HARRISON, ROYDON, WARE

## ROYAL WEDDING

COMMEMORATION PACKET FREE



The historical stamp portraying the Royal Family is included in this collection of different stamps covering 100 years of the House of Windsor. Old Victorian (1841), Duke of Windsor, King George V, Present King and Queen, Royal Princesses and Duke and Duchess of Gloucester. Sets of Canadian, Dutch and Argentine, scarce Bavarian, one from Lieut. Mountbatten's country, Greece, and European issues. Absolutely free. Just send 3d. postage and request our famous approvals.

LISBURN & TOWNSEND LTD. (MM)

1a, BRONTE ST., LONDON RD., LIVERPOOL 3

## FREE GIFT OF STAMPS

to every applicant for approval books. The GIFT contains 30 British Colonials including 8 K.G. VI mint—no Great Britain. Good discount is given and a list of 98 Gifts is sent. These can be chosen by you and vary in value according to the money sent for purchases. They include K.G. VI Mint, Silver Jubilees, ALL the Coronation Sets and Foreign. 3d. postage please.

C. A. RUSH, 38, Queen's Avenue, Whetstone, London N.20

**FREE!**



**UNIQUE**

**"DIAMOND AIR"  
PACKET**

includes this beautiful  
2-Colour Air Stamp  
(reduced illus.)

and 10 other desirable  
stamps. Just send 2½d. postage,  
& ask to see Special 'Mercury' Approvals

Philip J. Dyke (P.T.S.), 35, Buckleigh Ave., London S.W.20



# Stamp Collecting

## Two Railway Centenary Issues

By F. Riley, B.Sc.

RAILWAYS have often provided subjects for stamp designers, and many of the very effective stamps of this kind they have given us have been illustrated and described in articles in the "M.M." Further excellent examples of railway stamps have come



recently from Denmark and Switzerland, countries which this year have celebrated the completion of 100 years of railway working. The stamps are extremely attractive in themselves and their railway interest must make them doubly

attractive to "M.M." readers. The Danish issue comprises three stamps, all of which are illustrated on this page. Each has on it the dates 1847-1947 to mark the country's railway centenary. Actually the first connected Altona and Kiel, and was opened in 1846 but this part of the country was annexed by Prussia in 1864, and so the centenary date for Denmark itself became 1947, one hundred years after the opening of a line from Copenhagen to Roskilde, about 20 miles away. Nine years later the line was extended right across the island of Seeland, on which Copenhagen stands. It was not until 1862 that construction began on the mainland, but after that time railways were extended rapidly, mainly under the direction of British engineers. Eventually the lines were brought together as a State system.

The first two locomotives used on the Copenhagen and Roskilde line also were British. They were inside-cylinder 2-2-2s built by Sharp Stewart and Co. Ltd., Manchester, famous pioneer locomotive builders of this country. One of them is illustrated on the 15 ore value, which is reproduced on this page. They rendered splendid service, and one of them was actually in operation until 1888, forty-one years after it reached Denmark. The modern locomotive shown on the 20 ore value of the centenary issue provides a very interesting contrast. A notable feature of this engine is the band on the chimney, which is in red, white and red, the Danish national colours. This is an interesting extension to locomotives of the practice of using distinguishing colour bands on the funnels of ships.

In many respects the scene shown on the 40 ore value is the most interesting of the three Danish



system of train ferries has now been developed. The 40 ore value gives a good idea of the size of the vessels employed in this service in Denmark. From Denmark, the land of train ferries, we may now turn to Switzerland, the country of wonderful railway tunnels. The first Swiss railway connected Zurich with Baden, and was a line 14½ miles in length. The scheme for building it had been discussed for more than 10 years, and the proposal really was to construct a line from Basle through Zurich to Lake Constance. After various negotiations the more modest plan was actually adopted, and the first train ran on it on 9th August 1847. To begin with there were four trains each way daily, with an extra train on Sundays and holidays, and the trip was made in 45 minutes.



railway designs. The country consists of three large main islands in addition to the mainland section of Jutland. Formerly steam boats were used to maintain communication between the islands, and the necessity for changing from train to boat and back again to a train when passing from one island to another, or crossing to the mainland, led to a considerable waste of time and caused great inconvenience. In order to avoid these a splendid



system of train ferries has now been developed. The 40 ore value gives a good idea of the size of the vessels employed in this service in Denmark.

From Denmark, the land of train ferries, we may now turn to Switzerland, the country of wonderful railway tunnels. The first Swiss railway connected Zurich with Baden, and was a line 14½ miles in length. The scheme for building it had been discussed for more than 10 years, and the proposal really was to construct a line from Basle through Zurich to Lake Constance. After various negotiations the more modest plan was actually adopted, and the first train ran on it on 9th August 1847. To begin with there were four trains each way daily, with an extra train on Sundays and holidays, and the trip was made in 45 minutes.

As in the case of the Danish railway centenary issue, the Swiss set shows on its lowest value the first locomotive to run on the country's earliest line. This was one of two wood-fired engines built at Karlsruhe in Germany, and the name it carried was "Limmat," that of a river the valley of which was followed by the railway. This engine is illustrated on the 5c. value, and the 10c. value shows a modern steam locomotive that provides a no less instructive contrast than that between the engines shown on the two lowest value stamps of the Danish issue.

The remaining two stamps of the Swiss set, the values of which are 20c. and 30c. respectively, illustrate another modern development. The Swiss railway system is remarkable not only for its wonderful tunnels under the Alps, but also for the use it now makes of power generated in hydro-electric stations. The electric locomotive indeed has displaced the steam engine to such an extent that four-fifths of the Swiss Federal Railway system is worked by electric traction, and the electrified system actually carries about 95 per cent. of the total traffic. Diesel and diesel-electric locomotives also are in use, and a trial is being made of a gas turbine engine.

The 20c. value shows an electric express train on the Gotthard line, while on the 30c. value electric trains are seen crossing a bridge. There are almost 3,000 underline bridges on Swiss Railways, with a total length of 48 miles, and 862 bridges carry roads over the tracks.





## BALLOON STAMP FREE

YOU can get from us **ABSOLUTELY FREE** this valuable stamp of **BELGIUM**, which shows Prof. Piccard's Balloon. This handsome and large stamp was issued in 1932 to commemorate Prof. Piccard's two ascents into the stratosphere for scientific research.

These stamps are slightly cheaper now than in 1945 when catalogued 2/- each, and we will send one **ABSOLUTELY FREE** to each approval applicant. Just ask for Balloon stamp (free) and selection of our stamps on approval, and enclose 3d. stamps for our postages.

**WINDSOR STAMP CO. (Dept. M)  
UCKFIELD, SUSSEX**

## TEN LARGE DUTCH PICTORIALS

In fine used condition, sent entirely **FREE** if you ask to see approvals and enclose 3d. stamp for postage and packing. Without approvals the packet will be supplied for 1/-.

**Special Offers of Fine Used Stamps.**—France, Three Peace Conference, 2/6. United States, complete set, 32 Presidentials, 17/6. Four Roosevelt Memorial, 1/6.  
**W. C. LE MERCIER, BISHOP'S WALTHAM, HANTS.**

## SWITZERLAND S.G. Large Catalogue Numbers.

1d. to 3d. items, please send Wants List. 4d. ea.: 380, 391g, 391i, 393f, 393g, 394f, 407, 408, 417, 426, 427g, 430, 441, 442, 461, 465\*, 467, 471, LE22\*, C68, C69, C70, C72, C73, C74, C76, C77, C78, C80, C81, C82, C84, C85, C86, C88, C89, C90, C92, C93, C94, C96, C97, C98, C100, C101, C102, C104, C105, C106, C108, C109, C110, C112, C113, C114, C116\*. 6d. ea.: 101, 112\*, 300, 302, 354, 363, 364, 392i, 396f, 396g, 396i, 401, 402, 410, 411, 413, 418, 424, 425, 427i, 430\*, 431, 432, 434\*, 437, 438, 439, 450, 462, 463, 468, 469, C16, C17, C18, C22, C25, C28, C30, C34, C44, C45, C46, C52, C53, C60, C64. 8d. ea.: C13, C24, C26, C29, C32, C33, C36, C37, C38, C40, C41, C42, C48, C49, C50, C54, C61. 9d. ea.: 67, 113\*, 177, 290, 317a, 338, 342, 349, 381, 393i, 397f, 397g, 397i, 412, 428, 429, 443, 460, C1, C15, C20, C21, C56, C57, C62, C65, C66, C117\*. 1/- ea.: 63, 350, 368, 384, 399, 400, 419, 435\*, 436, 445\*, 451, 452, 453, C35, C58, C118\*.

Please send Wants Lists for others.

**FRED HARLOW, B.P.A.,**

133, BRADBOURNE VALE, SEVENOAKS, KENT

## FREE—STAMPS CATALOGUED 5/-

to applicants for 3d. approvals  
**COX, 17, STONELEIGH PARK ROAD, EWELL**

**50 DIFFERENT STAMPS. ALL 1d. EACH.** Only Splendid Pictorials and New Issues 4/2 plus post. Any stamps not required or to avoid duplicates can be returned for entirely different Packets of 50 stamps. The ONLY BRITISH EMPIRE Stamp Albums giving all VALUES, COLOURS, CATALOGUE and THREE SQUARE PERFORATION PANELS (Copyright) 2/6 and 3/6. WHOLE WORLD 3/6, PEACE 2/6. Post 7d. extra.

The Western Imperial Stamp Co., Trowbridge, Wilts.

## BARNET & FORD

THE STAMP SHOP

5b, High Street, CONWAY, N. Wales  
EMPIRE CATALOGUES

WHITFIELD KING, 1948, Part I	.. 8/3	} Post	
REGENT, Part II, September, 1947	.. 3/3		} Free
RELIANT, Complete 1948	.. 6/4		
U.S.A. Album (illustrated and bound)	.. 7/9		

## EXTRA SPECIAL BRITISH COLONIAL VARIETY PACKET FREE

This magnificent packet of specially selected stamps will be sent to you absolutely free per return of post

Each packet includes Scarce Jubilee, large Coronation, recent Victory, Zoological and latest New Issue Stamps.

Send immediately 2½d. towards postage and request our Famous Bargain Discount Approvals. Personal Service, no rubbish.

Write to-day:

**L. E. THOMPSON  
70, Cavendish Avenue, London W.13**

## ROYAL WEDDING FREE!

The very latest Australian Stamp showing the new Portrait of Princess Elizabeth, issued on the day of the Royal Wedding, will be sent quite free to new customers for our special "1d. Upwards" approval selections. Write to-day, enclosing 2½d. stamp for postage to:

**CAPT. M. CAMPBELL & CO. (Dept. MM)  
58, High Street, Watford, Herts.**

## GIVE THEM STAMPS THIS CHRISTMAS

I have a large selection of British Colonials and foreign. SEND for a selection on approval. Liberal discount.

20 Colonials free to each applicant. Without approvals the 20 Stamps, Price 9d. Postage 2½d.

**S. H. FLEMING**

NEWHAVEN, GLYN AVENUE, COLWYN BAY

## APPROVALS AND PRIZES

All the Crown Colonies, from Aden to Zanzibar, in sets, but priced singly, are included in these Approvals, as well as Victory & Royal Visit Issues, and a fine selection of Foreign. Good discount given, and full details of monthly prizes sent with first selection.

November Winners:—0402, 0425, 0468, 0499, 0527

**G. E. MOAT**

"Loewards," Glastonbury Chase, Westcliff-on-Sea, Essex

**USED VICTORIES.** Br. Honduras 1½; Ceylon 9d.; Dominica 1/-; Gambia, Gibraltar or Jamaica 8d.; Sierra Leone 9d.; Hong-Kong 4½. Postage 2½d. B. Purcell, 22, Green Lane, Amersham, Bucks.

# Stamp Gossip

## and Notes on New Issues

By F. E. Metcalfe

BRITISH Colonies, particularly the smaller ones, rely a good deal on the revenue they derive from the sale of their postage stamps. British collectors would still be interested in them if they were not pictorials, but they would not be anything like so



popular with foreign collectors. Even as it is, it looks as though they may be up against stern competition from French colonial stamps, for recently some magnificent sets of the latter have been issued and the French authorities are backing them up by an extensive advertising campaign. This is carrying things too far, and as a matter of fact they are issuing too many stamps as well, but one cannot refrain from admiring the beauty of some of their stamps. We are illustrating one which speaks for itself.

Collectors living in the big cities, where there are stamp shops, are able to get an album of sorts, but grumble that they are not able to get any of fine quality, with hand made paper leaves. Well, everybody apparently is in the same boat, for it is said that even the King cannot get albums to match those which he used previously for his own particular collection of KG VI issues. This collection is known as the "Blue," owing to the fact that the covers used are of blue morocco—that formed by King George V is housed in red albums—and not only does His Majesty collect all Empire stamps issued during his reign, but also the drawings, etc., made by the designers of the stamps. Complete though this is, the collection which really counts is the one made by the late King George V. Here we have a collection comprising 350 volumes; all are Empire stamps, and it is said that every Empire stamp ever issued is to be found in it except the famous British Guiana 1c. black on magenta.

During the war crude stamps prepared in France for ordinary postal use bore the head of General Petain. Their crudeness made it easy to forge them, and this was done extensively in London. They were then secretly shipped over to France and used by the resistance movement. It is difficult to find genuine used copies, for recipients had to burn the letters, carrying them for safety, but mint copies are fairly plentiful, and interesting as these stamps are, big prices should not be paid for them.

Perhaps the most popular stamps issued in the British Empire are the annual "Health" stamps of New Zealand. This year's design features "Eros," the famous statue that stands in Piccadilly Circus, quite a happy choice, and the New Zealand charity will as usual benefit substantially. We have already mentioned that according to report

India is planning a similar set annually.

Last month we illustrated one of the three values issued by Australia to commemorate the sesquicentenary of the founding of the city of Newcastle. This month we are showing another of the stamps that was supposed to bear a portrait of Lt. John Shortland, R.N., the founder of the city. There had been a slip, however, and instead the portrait is one of his father. Quite an interesting error. Of course there are plenty of the stamps about, and so they are not likely to be rare.

Apparently South Africa is going in for a new set, and it is understood that a committee will be formed to judge the designs. In theory the idea of a selection committee is a good one, but the result is not always a nice set of stamps. As a case in point, two of the poorest of all the British Empire stamp sets were those marking the tercentenary of Barbados and the Constitution set of Jamaica, and these were the selections of special committees. Half-baked designs

are handed over to the poor professional engravers and they have to try and make something of them. Let us hope that the South African committee will show better judgment.

As a matter of fact, as has been previously mentioned, the present South African stamps are intensely interesting to the philatelist, with all the shades, dies, etc., and a mint set—in pairs, of course, as the stamps are alternately printed in

English and Africaans—bought to-day at current rates will be well worth having.

Australia's current stamps are also worth buying, for with so many collectors both at home and in the U.S.A. devoting their energies to King George VI mint stamps, the demand seems to exceed supplies, in Great Britain at any rate. Hitherto many collectors have only gone in for used stamps of Dominions like Australia; they were so much cheaper, but with more money to spend, mint are now increasingly popular.

A stamp for which we could not find room last month was one of particular interest to British collectors. It is a French one issued to commemorate the St. Nazaire raid. It is attractive, as are all modern French stamps, and its price of a copper or two means that all collectors can afford a copy.

The recently issued "Lighthouses" set of New Zealand has proved very popular and this has drawn collectors' attention to the modest little stamps which the "Lighthouses" superseded. Collectors are wanting the previous issue, but it now transpires that just prior to the emission of the pictorial set—a matter of days—the old set appeared on the multiple watermark paper. It was known that the 1d. and 3d. had come out thus, but the ½d., 2d. and 6d. values came and went before hardly anybody was aware of them. Search your copies; they may be rare "mult. Wmk."



## From Our Readers

*This page is reserved for articles from our readers. Contributions not exceeding 500 words in length are invited on any subject of which the writer has special knowledge or experience. These should be written neatly on one side of the paper only, and should be accompanied if possible by original photographs for use as illustrations. Articles published will be paid for. Statements in articles submitted are accepted as being sent in good faith, but the Editor takes no responsibility for their accuracy.*

### THE KAIKORAI CABLE CARS

The picturesque cable cars of Dunedin have rumbled up Stuart Street since the beginning of the century, but have now been abandoned. This is the first of the three lines to be dismantled in favour of trolley buses which will replace the whole of the transport system in Dunedin. At 5.45 p.m. on 31st July last the order was given to close the line down. At 11.15 the last car gripped the cable for the short trip to the sheds. The passengers on board all received a free trip and a souvenir ticket. At 11.20 the power was cut and the engines stopped for the last time. The squat cable cars may be sold and the car sheds converted into a public hall. The machinery will probably be sold as scrap.

The proposal to run a tramline from the Octagon to Kaikorai was first made in 1894, and in 1895 a company was formed. A formal beginning was made with the building of the line on 29th June 1897. The estimated cost for a double line was £16,000 but the final cost was £23,000. The official opening was on 6th October 1900. On the following 22nd October the line was opened for passenger traffic and 23 weeks later the trams had carried 250,000 passengers. In succeeding years the number of passengers carried was over 750,000 annually, and in 1939 the company sold the undertaking to the City Council.

Although this line was not the steepest in the city it provided a thrill for old and newcomers as these springless, box-like cars jolted up and down the 1 in 7 grade. Swinging monkey-like along the side of a crowded car was not easy for a conductor with clipper in one hand. It was an all weather job, but most of the men stayed to graduate as gripmen.

The motive power for the cable was supplied by a Tangye engine of 175 h.p. The cylinder dimensions were 16 in. by 32 in., and the engine made 75 r.p.m. The working pressure was 100 lb. per sq. in. Although the boilers were automatically stoked, during the peak periods they had to be hand-stoked as well. The cable that hauled the cars weighed 12½ tons and was 12,605 ft. long. The best cable lasted 671 days. It travelled 139,660 miles and conveyed 2,123,980 passengers.

G. DITCHFIELD (Dunedin, New Zealand).

### A NOVEL USE FOR MECCANO

With the aid of Meccano, Arthur Rowland, aged 10 years,

of Guisborough, Yorkshire, won first prize in this year's Guisborough Carnival for the best decorated juvenile cycle, seen in the accompanying illustration. The entire framework of the house is made up of Meccano Parts. Its sides and roof are made of old blankets and black-out material, sprayed with

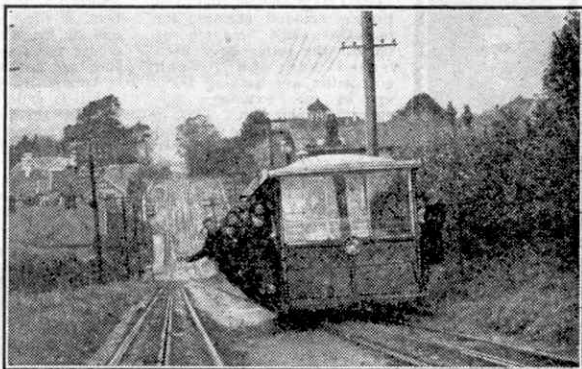

A Dunedin, New Zealand, cable car climbing a hill. Photograph by courtesy of the "Evening Star," Dunedin.

distemper and paint, and an ingenious Meccano mechanism caused the arms of the figure on top to work when the wheels of the bicycle revolved.

J. INNES (Guisborough).

### A VETERAN BRITISH SAILING SHIP

The schooner "Katie," which was the only commercial vessel in the British Isles that had no auxiliary motor, has been sold to Denmark. She was built at Padstow in 1881, and is 88.6 ft. long, 22.6 ft. in beam and 12 ft. deep, with a gross tonnage of 119. This fine old vessel has some excellent runs to her credit.

"Katie" began as a two-masted topsail schooner, but was later altered to the patent topsail or Garibaldi rig. She was engaged for many years in the china-clay and cement trade. An interesting point about her was a permanent unexplained list to starboard, which necessitated loading several tons more on one side than the other. She sailed as an auxiliary for a short time before the war, but this proved unsatisfactory, and the engines were removed. In September 1940 she was attacked by a German bomber, and some bullets damaged her in several places.

C. M. STEPHENS (Par).



A decorated cycle that won a prize for a Magazine reader. Photograph by J. Innes, Guisborough.



# Competitions! Open To All Readers

Prize-winning entries in "M.M." competitions become the property of Meccano Ltd. Unsuccessful entries in photographic, drawing and similar contests will be returned if suitable stamped addressed envelopes or wrappers are enclosed with them.

## Advertisement Letter Square

We are basing our main competition this month on the advertisements in the present issue. On this page is a square consisting of 81 letters. These have been so arranged that in them can be traced the names of products advertised in this issue, or of the firms advertising them. In certain instances the full name is not given, but in all cases there is sufficient to make for complete identification.

The names, 18 in number, are traced by starting anywhere and passing at each move to the letter on the left or right, or that above or below. No diagonal moves must be made. There is no restriction on the number of times that a letter can be included, but each letter must be used at least once. In their solutions competitors must give

O	R	D	I	C	S	S	A	B
F	R	C	U	L	E	B	O	N
L	E	K	W	O	T	A	S	D
A	H	N	O	L	T	S	N	U
S	T	A	B	A	R	O	L	R
A	I	C	C	E	H	P	V	E
L	P	I	N	M	A	T	I	A
A	I	R	E	L	L	H	Y	B
N	G	T	Y	T	I	O	R	N

the names of the products or advertisers concerned, together with the numbers of pages on which the advertisements appear.

Entries should be addressed "Advertisement Letter Square, Meccano Magazine, Binns Road, Liverpool 13." There will be two sections in the contest, for Home and Overseas readers respectively, and in each prizes of 21/-, 15/- and 10/6 will be awarded, and there will be consolation prizes for other good efforts. If there is a tie for any prize the judges will take the

neatness and novelty of the entry itself into account in making their final decision.

The closing date in the Home Section is 31st January 1948, and that in the Overseas Section 31st July 1948. Competitors must take care to put their names and addresses on their entries.

## Find These Railway Names

Most of our readers are familiar with the names of the great railways of the United States, for practically all of these have been mentioned in the "M.M." from time to time. Our railway competition this month is based on the names of 12 of them. In the list given below several letters have been left out of each name, and their places marked by asterisks. The simple task set to readers is to fill in the correct letters in order to form the full title. The words railway or railroad are not included.

1. C\*E\*A\*E\*K\* AND O\*\*O
2. B\*S\*\*N AND M\*I\*E
3. L\*H\*GH V\*L\*EY
4. \*N\*ON P\*C\*F\*C
5. W\*S\*E\*N PA\*I\*IC
6. G\*E\*T N\*R\*H\*RN
7. E\*IE
8. C\*N\*R\*L V\*R\*O\*T
9. I\*L\*N\*IS C\*N\*R\*L
10. W\*S\*E\*N M\*R\*L\*ND
11. P\*RE M\*R\*U\*T\*E
12. C\*L\*R\*DO AND S\*UT\*E\*N

In order to make clear what is wanted we may take the first name on our list. After examining it for a short time it will be seen to represent the railway that has

the familiar title of CHESAPEAKE AND OHIO.

The competition as usual will be divided into two sections, for Home and Overseas readers respectively, and in each there will be prizes to the value of 21/-, 15/- and 10/6, with several consolation prizes.

Entries should be sent to "December Railway Contest, Meccano Magazine, Binns Road, Liverpool 13." Closing dates: Home Section, 31st January 1948; Overseas Section, 31st July 1948.

## December Photographic Contest

This month's photographic contest is the 12th of our 1947 series, and in it, as usual, prizes are offered for the best photographs of any kind submitted. There are two conditions—1, that the photograph must have been taken by the competitor, and 2, that on the back of the print must be stated exactly what the photograph represents. A fancy title may be added if desired.

Entries will be divided into two sections, A for readers aged 16 and over, and B for those under 16. They should be addressed "December Photographic Contest, Meccano Magazine, Binns Road, Liverpool 13." There will be separate sections for Overseas readers, and in each section prizes of 21/-, 15/- and 10/6 will be awarded. Closing dates: Home Section, 31st December; Overseas Section, 30th June 1948.

# Fireside Fun

"Haven't I seen your face somewhere else, my boy?"  
"No, sir. It always stays here between my ears."

"How are you getting on at school, John?"  
"Be a sport, dad. I never ask you how you're getting on at the office."



"What a lot of the congregation had bad coughs this morning."  
"Them weren't coughs, sir. They were time signals."

"How is your friend doing out in Australia?"  
"Oh! He is carrying everything before him."  
"What business is he in?"  
"He's a waiter in a restaurant."

Tom: "There's one thing I can never do without putting my foot in it."  
Pete: "What's that?"  
Tom: "Put on my boot."



"That's Sir Kenneth Kennel. He gave many big sums to the school."  
"Couldn't he do them himself, sir?"

## BRAIN TEASERS

### HOW DO WE START THIS ONE?

"If £100 were to be divided between a certain number of men, how much would each get?"  
"I can't see how to work that one out, but perhaps I can tell you next month. In the meantime here is one for you to work out. How many is half of 2 and 2?"

### A KEYWORD THAT DOESN'T QUITE FIT

In the multiplication sum shown below each letter represents a definite number. If these are arranged in order, beginning with the letter representing 1, the first eight letters of the name of a famous city are formed. This city has nine letters in its name. Which is it?

$$\begin{array}{r}
 \text{I R E G} \\
 \text{I E N} \\
 \hline
 \text{E N G R D} \\
 \text{I R E G} \\
 \hline
 \text{E E E B N} \\
 \hline
 \text{E E U R N B D}
 \end{array}$$

B.I.N.



"He's all right. He doesn't bite."  
"But does he swallow?"

Can you name the nine world champion boxing classes, and give the maximum weight for each?

### SOLUTIONS TO LAST MONTH'S PUZZLES

Although the man in the train in our first puzzle last month counted 12 telegraph poles in the half minute, the distance between the successive poles has to be multiplied by 11 in order to get the total distance. This gives the speed as 660 yds. per half minute, or 45 m.p.h.

The code used in our second puzzle consists simply in substituting for each letter in the original either that before it or the one after it in the alphabet. Thus for the letter E either D or F could be substituted. The solution is "A STITCH IN TIME SAVES NINE."

If the matches in our third puzzle last month are numbered 1 to 8, from left to right, then the four moves required are 5 to 2, 3 to 7, 1 to 4 and 6 to 8.

### THIS MONTH'S HOWLER

The crew of each boat in the Oxford and Cambridge Boat Race consists of eight men and one man to coax them.

## INDEX

Vol. XXXII

Jan.—Dec., 1947

- Aerial Ropeway** for Indian Cement Works, 270  
**Aircraft**:—Avro "Tudor," 310; Carrier-borne, 434; Douglas "Skytreak," 353; Helicopters, 466; Jet Fighters, 6, 479; Lockheed "Constitution," 74; Saunders-Roe Jet Flying Boat, 479; U.S. Personal "Planes," 160  
**Air News**, 22, 66, 106, 154, 202, 234, 282, 318, 366, 402, 442, 486  
**Aviation**:—Aircraft Parts pressed by Rubber, 362; Air Inventions, 98, 146; B.O.A.C. New Aircraft Markings, 269; Bristol Rotor Test-Rig, 395; Fairey Guided Missile, 279; Hythe, Home of the Flying Boats, 118; L.A.M.S., 246; London's Airports, 54; New and Old in the Air, 190  
**Bell**, Birth of a, 62  
**Bells**, Liverpool Cathedral, 114  
**Books to Read**, 16, 69, 70, 108, 193, 244, 273, 322, 361, 394, 473  
**Britain Relights the Seas**, 484  
**Caisson** for French Dry Dock, British, 432  
**Circus Dare-Devil Feats**, 14  
**Conjuring Tricks** for Christmas, 474  
**Cornish Pumping Engines**, 286  
**Deep Channels**, 28  
**Editor**, With the:—Brunel's Timber Viaducts, 49; Bell and Telephone, 97; Coal Saving on Irish Sea Routes, 145; Greenly, Model Railway Pioneer, 185; Atlantic Records, 225; Flying Faster than Sound, 265; Motor Racing, 145; 305; American Railway Equipment, 305; Life-boat Service, 345; First Weather Ship, 345; Erikson, "Last of the Vikings," 385; Calling all Cars, 425; 400 m.p.h. on Land, 425  
**Engineering Apprentice Training**, 9  
**Engineering Notes**, 25, 173, 237, 285, 360, 433, 478  
**Ford**, Story of Henry, 238  
**From Our Readers**, 30, 79, 125, 182, 221, 257, 301, 335, 380, 415, 455, 500  
**Goldie Gardner** and his M.G., Lt.-Col., 316  
**Have you ever thought about this?**, 20, 65, 113, 164, 272, 326, 356  
**Hornby-Dublo Railways**:—Hints, 333; Lineside Features, 85; Methods, 475; Track Formation, 37  
**Hornby Gauge 0 Railways**:—"Castleford and Darlington," 87; "Churchtown" Railway and Tramway, 38; Engine Sheds, 133; Goods Yards Schemes, 294; Hints for Beginners, 86, 417, 456, 495; Hornby Engines, 375; Hornby (N.C.C.) Layout, 334; "Methuen Park Railroad," 174; "Model City," U.S., 416; Muirhead North Electric, 134; Operating Oddments, 214; Rolling Stock, 255; Secondary Tracks, 457; Simple Layout Running, 215; Waterloo (Dublin) H.R.C. Branch, 254  
**House Ahoy!** 12  
**Meccano Dinky Supertoy**s, 323  
**Meccano Models**:—Aerial Roundabout, 292; Bridge, 128; Charioteer, 452; Crane, Dockside, 492; Crane, Mobile, 372; Delivery Truck, 292; Dumping Truck, 251; Locomotive, 171; Loom, Hand, 128; Meccanograph, 451; Mechanical Horse and Trailer, 452; Mechanical Shovel, 250; Motor Truck, 82; Pistol, 83; Rocking Horse, 129; "Shoot-a-Ball" Game, 34; Skittle Game, 35; Spring Balance, 328; Stacker, 170; Steam Roller, 208; Tramcar, 328; Wagon, Steam, 493; Weighing Machine, 293, 412; Wire covering machine, 329  
**Model-Builders**, Among the:—Band Brake, 130; Brake, screw-operated, 82; Clutch, 82; Contact Printer, 210; Crane, remote controlled, 168; Cranks, 370, 410; Crankshaft, 32; Destroyer, 211; Developing Dish Agitator, 330; Differential, 210; Dog Clutch, 169; Gear, Unusual, 32; Intermittent Motion, xxx; Looms, 252-3; Model Ship Mechanisms, 130, 331; Ratchet Brake Lever, 491; Reversing Mechanisms, 252, 290; Rotary Bearing, 371; Shelf Bracket, 252; Shock Absorbers, for vehicles, 130; Steering Mechanisms, 32, 330, 410; Winding Gear, 168; Winding Mechanisms 490; Vice, 290  
**Model-Making** in Switzerland, 110  
**Motor Bus**, Age of the, 232  
**Nature**:—Birds and Locomotives, 212; Birds in Flight, 276; Nature's Lesson in Camouflage, 324; Snake Charmer, World's Youngest, 309; Snakes of Great Britain, 404; New Trees and New Jobs, 430; Watching Water Beetles, 194  
**Of General Interest**, 26, 175, 450  
**Peat and the Coal Shortage**, 76  
**Photography**:—Against the Light, 127; Gaslight Prints, 401; Holiday Album, 441; Park, 368; Seaside, 327; Snow and Frost, 31; Springtime, 201; Summer, 249; Waterside, 288; Winter, 75  
**Radar Aids Navigation** at Sea, 4  
**Railway Locomotives**:—British of the Near Future, 204; "East Lancashire Regiment," L.M.S., 308; G.W.R. "Dean" 0-6-0s, 68; L.M.S. Diesel Developments, 236; L.M.S. (N.C.C.) Tank Engines, 24; L.M.S. Tender and Tank Engines, New, 50; Swiss Gas Turbine, 358; Tapered Boiler for L.M.S. "Patriots," 126  
**Railway Notes**, 10, 58, 116, 166, 196, 242, 274, 314, 354, 406, 446, 482  
**Railway Runs**:—"Devon Belle," Trip on the, 449; "Turbotomative," Footplate Trip on the, 390  
**Railways**:—A Railwayman Abroad, 2, 72, 122; Brake-Testing with Artificial Rain, 121; Caledonian Railway Centenary, 346; County Donegal Joint, 289; Dublin Eastern Suburban Trains, 477; Egyptian State Railways, 438; Glasgow Subway, 149; G.N.R. (1) "Enterprise" Express, 444; Kalka-Simla, 429; Kent and East Sussex, 104; Limestone Traffic from the Peak, 480; London's Underground Extension, 100; New Signals for Old, 18; Notes on Swiss, 320; Pennsylvanian Railroad Main Line Relocation, 306; Renewing Hademore Troughs, L.M.S., 156; Signalman's Job, Aspects of, 229; S.R. All-Pullman Train, 364; Station-on-Sea, 13; Tal-y-Llyn, 396; Trent Valley Centenary, 470; Welding in Permanent Way Maintenance, 290  
**R.N.L.I.**, Story of the, 352  
**Road and Track**, 64, 165, 278, 365  
**Sailor Remembers**, A, 163, 207, 241, 313, 445, 472  
**Salmon**, Strength of, 57  
**Seaweed Industry**, 271  
**Shipbuilding** as a Career, 398  
**Shipping Notes**, 400  
**Ships**:—Anchor Line War Losses, 21; "Asturias" Story of the, 392; "Butterfly Boat," 266; Decoration of, 426; "Great Admiral," 409; "Hinemoa," N.Z. Ferry Steamer, 349; Liberty, 53; "Media," Cunard White Star Liner, 440; Model, 198; Nelson Sisters, 284; "Port Hobart," Refrigerated Cargo Liner, 103; "Queen Mary" in Service Again, 389; "Reina del Pacifico," 357; Royal Mail Cargo Liners, 317; Ships with Wings, 434; Tug Family, 226; "Ulster Monarch," 469; Union-Castle Line, 186  
**Stamp Collecting**, 41, 89, 137, 177, 217, 259, 297, 337, 377, 419, 459, 497  
**Taxi Cab**, New London, 124  
**Tea**, Story of, 158  
**Transport**, Outside, 152, 350  
**"Trojan"** Two-Stroke Engine, 120  
**Turbo-Alternators**, Parsons, 60

# Students' Microscope

made specially for young scientists



A wonderful present!

A splendid idea! Choose this Students' Microscope for a Christmas or Birthday present, and explore the astonishing world of science! The model shown magnifies 100 times, is 7½ in. high, is capable of very fine adjustment by means of rack and pinion operated by milled heads and curved limb with pivot screw. Fitted with plane silvered mirror. Strongly and beautifully made. In polished wood cabinet (shown on left), 88/- In rigid carton, 60/- Two smaller models, 30/- (Mag. 70×), and 25/- (Mag. 44×). No purchase tax. All models sold with Accessories and Instruction Book.

Ask for S.E.L. Products  
at all good Dealers and Stores

*Model Steam Engines, Plastic Telescopes, Pocket Compasses, Electric Motors, Transformers, Electrical Outfits, Dynamotors, Induction Coils, Electric Bells, Bell Pushes and Switches, Morse Practice Keys and Buzzers, Stamp Magnifiers, etc.*

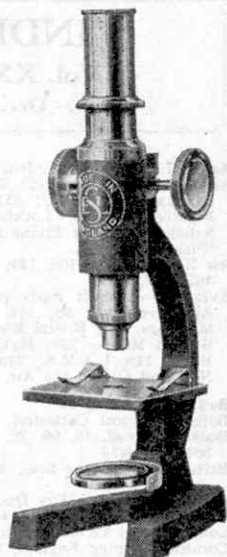

**SIGNALLING EQUIPMENT LTD., Merit House, Potters Bar, Middlesex**

AMATEUR PHOTOGRAPHERS WHO MAKE THEIR OWN  
PRINTS SHOULD OBTAIN ONE OF THESE FRAMES

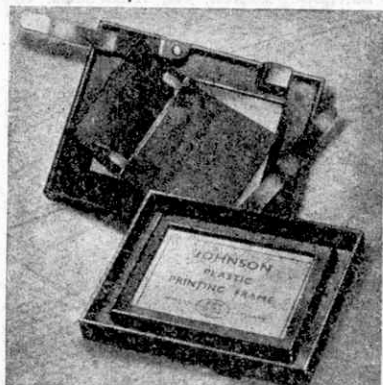

## JOHNSON PLASTIC PRINTING FRAME

**T**HIS new contact printing frame is moulded in one piece in hard plastic with squared-up sides and ends. The hinged back fits accurately and cannot slip or slide. Sturdy steel springs exert an even pressure over the whole surface of the negative and paper. The smooth, dead-level precision of this well-fitting plastic back will be a delight to those who, in the past, have had trouble with wooden frames which have warped.

Made in one size only with glass for films  
up to 2½ x 3½ inches

PRICE 3/6

Sold by all photographic dealers



**JOHNSONS OF HENDON**  
PHOTOGRAPHIC CHEMICALS AND APPARATUS





You'll lick them all  
when you fit  
the new

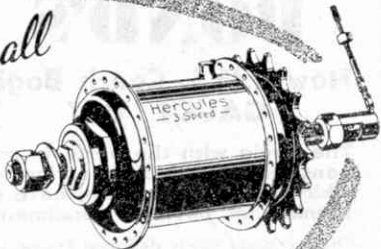

## Hercules 3 - SPEED HUB

This modern precision-built 3-Speed Hub has already been fitted as original equipment to many thousands of Hercules Cycles and is unexcelled in performance. Now it is available for servicing any make of cycle. It is an epicyclic 3-Speed Hub, machined to precision engineering limits from the finest

materials including Chrome Alloy Steel, and subjected to most careful heat-treatment. Ratios 33 $\frac{1}{3}$ % Normal to High; 25% Normal to Low. Completely effortless changing.

See your local dealer or write to us for name of nearest Dealer.

Manufactured solely by

**THE HERCULES CYCLE & MOTOR CO. LTD., ASTON, BIRMINGHAM**

W122G

YOUR  
FUTURE  
CALLING! **RADAR**



**WIRELESS  
TELEVISION  
RADIOLOCATION**

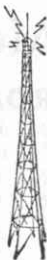

**The First Step to a Successful Career.** The developments and usages of RADAR in the post-war world create an ever-widening range of brilliant careers for the Youth of to-day, and opportunities for World-travel.

Specialist training for appointments in all Branches of RADAR, WIRELESS, TELEVISION, etc., is available at our Colleges.

- Boarders accepted in both Colleges.
- Recognised by Messrs. Marconi and all leading Radio Employers.
- On Air Ministry List.
- Licensed by H.M. Postmaster General.
- Organised Sport at both Colleges.
- Own Swimming Pool.
- Low Fees.

A few vacancies for admission.

Decide now to take the first step—write for Prospectus.

## WIRELESS COLLEGES

CALMORE, SOUTHAMPTON & COLWYN BAY, N. WALES  
Don't delay—send 2d. stamp at once to The Wireless College, COLWYN BAY, for Illustrated Prospectus

# LOTT'S TOY

**STONE BUILDING BRICKS.** The kiddies will never grow tired of playing with Lott's Bricks. Strongly made of coloured artificial stone and indestructible. Complete with plans for modern and Tudor style model houses.

**CHEMISTRY SET.** Give your boy a Lott's Chemistry Set and watch him pass in science with flying colours. Supplies are now available—plus a wide range of first-class spare apparatus. Ask your toy dealer for particulars.

**LOTT'S BRICKS LTD.**  
DEPT. M.M.2  
WATFORD, HERTS.

# BRICKS

**BOND'S****New L.M.S. Coach Bogie  
GAUGE "00"**

**The Bogie with the perfect compensation and bolster springing, which gives ball-bearing ease of running and obviates derailments**

These entirely newly designed Bogies are modelled on the L.M.S. 9-ft. wheel-base bogies. The brass sideframes are correct channel section, with superimposed dummy springs, which are riveted to the frames by means of machined axle-boxes. A specially designed bronze centre spring plate allows full compensation to each side member and good springing to the centre bolster, which is supplied with each bogie.

Price **11s. 6d.** per pair, plus packing and postage.

**BOND'S O' EUSTON ROAD LTD.**

357, EUSTON ROAD, LONDON N.W.1  
Phone: EUSton 5441-2 Est. 1887

**Make your own thrilling  
SCIENTIFIC DISCOVERIES**

Share the thrills of the atom scientist. Watch the amazing chemical changes from your own experiments, as they take place before your eyes. Start your own laboratory with one of Hamleys up-to-the-minute Chemistry Outfits.

**MADE IN 3 SIZES**

9/11 plus 9d. packing and postage  
15/7½ plus 1/- packing and postage  
29/4 plus 1/6 packing and postage

**FOR MORSE SIGNALLERS**

Combined morse buzzer and signalling key .. 6/6  
plus 5d. packing and postage

Extra quality buzzer only .. .. . 9/-  
plus 5d. packing and postage

SEND 2½d. FOR FULLY DETAILED LIST

**Hamleys**  
ESTD 1860

**HAMLEY BROTHERS LTD**  
200-202, REGENT ST., LONDON W.1  
(Our only address) Tel.: Regent 3161

**WILSON'S**

**LEADERS & PIONEERS**

PRESENT

**THE 'OCTOPUS STREAMLINER'**

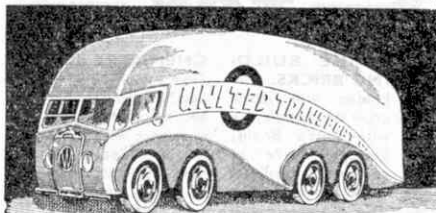

A new 4mm. scale streamlined freighter, latest addition to the Wilson lorry fleet. Kit includes fully shaped body, metal faced green and silver cabin and mud-guard fairings, three-colour transfers, 13 wheels and all the usual Wilson refinements.

Price **8'7** (including 1/7 tax)

4mm. catalogue and 7mm. leaflet  
1/- (P.O.) or leaflet only S.A.E.

**WILSON'S LORRIES LTD., Dept. M**  
1, GREAT WINCHESTER ST., LONDON E.C.2

**Modelcraft's** **NEW****ROADWAY KITS in 4 mm. scale**

- No. 1 4-wheel Leyland "Lynx" .. 3/6  
No. 2 6-wheel Leyland "Hippo" .. 4/3  
No. 3 8-wheel A.E.C. Mammoth Major 4/6  
No. 4 Foden Timber Tractor .. 5/-

**AND 4 NEW 'LINESIDE' PLANS**

- "Bedford" End-Tipper .. .. 6d.  
"Bedford" Single-Decker 'Bus .. 9d.  
"Aveling" Steam Roller .. .. 6d.  
"Maudslay" Brewery Lorry .. .. 6d.

**AND THE LATEST**

**Modelcraft**

**MAGAZINE & LIST No. 4**

**1/s** Articles, notes and hints by leading modelmakers and a longer list of plans, planbooks, kits and accessories than ever before. Direct or from your modelshop.

**MODEL CRAFT** 77(H), Grosvenor Rd.  
London S.W.1

# THE FUTURE IS YOURS PREPARE FOR IT NOW

**Maximum production, on which the life of the nation rests, depends on high technical skill. This gives marvellous opportunities to young men who have acquired such knowledge and efficiency as that contained in an I.C.S. Course of Instruction.**

**THE DEMAND FOR WELL-TRAINED MEN IS URGENT AND UNLIMITED — BUT THERE IS NO WORTH-WHILE PLACE FOR THE UNTRAINED**

*If you need technical training, our advice on any matter concerning your work and your career is yours for the asking—free and without obligation. Let us send you full information regarding the subject in which you are specially interested. DON'T DELAY. Make ACTION your watchword.*

**The successful man DOES to-day what the failure INTENDS doing to-morrow. Write to us TO-DAY.**

**The I.C.S. offer Courses of Instruction in a wide range of subjects, including:**

Accountancy	Joinery
Advertising	Journalism (Free Lance)
Aeronautical Engineering	Machine Designing
Air and Vacuum Brakes	Marine Engineering
Air-Conditioning	Mechanical Drawing
Architecture	Mechanical Engineering
Architectural Drawing	Mine Surveying
Auditing	Mining Electrical
Boilermaking	Motor Engineering
Book-keeping	Motor Mechanic
Building	Motor Vehicle Operation
Business Training	Plastics
Business Management	Quantity Surveying
Carpentry	Radio Engineering
Chemical Engineering	Radio Service Eng.
Chemistry, Org. & Inorg.	Railroad Engineering
Civil Engineering	Refrigeration
Clerk of Works	Salesmanship
Coal Mining	Sanitary Engineering
Commercial Art	Sheet-Metal Work
Concrete Engineering	Short-Story Writing
Cotton Manufacturing	Steam Engineering
Diesel Engineering	Structural Steelwork
Draughtsmanship	Surveying
(State which branch)	(State which branch)
Drawing Office Practice	Telegraph Engineering
Electrical Engineering	Textile Designing
Eng. Shop Practice	Toolmaking
Fire Engineering	Welding, Gas & Elec.
Fuel Technology	Woodworking Drawing
Heating and Ventilation	Woollen Manufacturing
Hydraulic Engineering	Works Engineering
Hydro-Electric	Works Management
Illumination Eng.	
Internal Comb. Eng.	

*And most of the Technical, Professional, Commercial, Educational and Civil Service Exams.*

*(Examination students are coached till successful.)*

**YOU MAY USE THIS COUPON**

*(Penny stamp on unscaled envelope)*

**INTERNATIONAL CORRESPONDENCE SCHOOLS LTD.**

**Dept. 218, International Buildings, Kingsway, London W.C.2**

Please send your free booklet describing I.C.S. Courses.....

Name..... Age.....

Address.....



## Some Fine Investments!

**MOTORS.** Electradix Micro Motors for instrument work and models 2 in. x  $1\frac{1}{2}$  in., weight only 10 ozs. 12/24 volts; work from dry cells or A.C. Mains through transformer, laminated fields, ball bearings, totally enclosed, small 'vee' pulley, centrifugal relay speed governor on shaft removable for second shaft drive. Precision made ex-W.D. stock. Worth 45/-. Price 21/- each. Limited stocks.

**MOTORS. D.C.** 230-volt D.C. 1/12 h.p., 1,500/2,000 r.p.m. shunt wound by Croydon, 25/-. 1/40 h.p. 110 v. or 220 v., 17/6. 1/30 h.p. 12-volt with 4-hole base plate, 75/-. 1/12 h.p. 220-volt D.C. motors needing minor repairs, 12/6; post 1/6 extra.

**TRANSFORMERS** for Models, 230-volts, 50 cy input, 220-volt 2-amps. output, 30/- 4-volts, 7½-amps. C.T., 17/6.

**TELEPHONES** for House or Office. Constructors' Parts for your own set-up. Ex-G.P.O. stocks, wall type, comprising Bracket Mike, Transformer and Condenser, Magneto Bell in walnut cabinet, 8 in. x 6 in. x 3 in., fitted terminals and connections, Switch Hook and Contacts, Hand Magneto Generator and G.P.O. Receiver, 35/- per pair, with wiring diagram. Moulded bakelite hand-combination telephones ex-G.P.O. with switch in handle, cord and plug, 15/-.

**DIMMERS or RHEOSTATS** with "off" 0 to 1 ohm and will carry up to 3 amps., for regulation on 6 to 12 volts, dimming or bank circuit battery charge model control, etc. One hole fixing with panels with bracket for other fixing. Hollow knob has socket for min. bulb, glowing when circuit alive. New U.S.A. Atena make, in carton, 2/6. Worth 5/-.

## ELECTRADIX RADIOS

214, Queenstown Road, London S.W.8  
(Late Queens Road)

Telephone: MACaulay 2159

## RADIO CONSTRUCTION

The finest results from the finest hobby—radio construction and operation—will be obtained by using

### SPARKS' DATA SHEETS

which provide full constructional details, theoretical circuit, full-size detailed prints of drilling, assembly and wiring plans, and component list of noted

### TESTED AND GUARANTEED DESIGNS

Here are a few of the many designs available in Data Sheet form. Send S.A.E. for full List "A."

**BATTERY OPERATED.** One-Valve Midget Portable M/L Waves, No. MP.1, 2/6; Three-Valve Ditto, Loudspeaker results, No. LO/S, 2/6; Two-Valve Midget, Med.-Waves, powerful 'phone sigs., 9 V. H.T., No. LO/M, 2/6; Two-Valve Speaker Set, M/L Waves, No. LO/12, 2/6; Three-Valve "Straight" Set, good speaker sigs., Med.-Waves, No. LO/3, 2/6; Four-Valve T.R.F. Set, M/L Waves, No. LO/4, 2/6; Four-Valve Ditto, No. LO/8, 2/6; Short-Wave Super Two, No. LO/2, 2/6; S.-W. Three-Valve No. LO/7, 2/6.

### SPARKS' DATA SHEETS

9, Phoebe Road, Brockley, London S.E.4

## HOBBIES FRETWORK OUTFITS

H.2 Outfits 9/6, H.3 Outfits 13/6, CROWN Outfits 17/6, NATIONAL Outfits 25/-, A.1 Outfits 30/-, A.3 Outfits 55/-, MODEL-MAKERS' Outfits 18/6. FRETSAWS, Blue Label, 1/2½, Yellow Label, 1/5½ per dozen.

ALL OUTFITS 1/- Postage and packing extra.  
Fretsaws 2½d. doz. postage extra.

### GEORGE D. CAMPBELL

91, GOLDERS GREEN ROAD, LONDON N.W.11

### LILLIPUT FARM FOR SALE !!

Fine full-bodied scale models in up to 8 colours, durable metal, standard size, including: Farmer (2½ ins.), Wife, Maid, Cattle, Horses, Pigs, Poultry, etc. 120 models for £3, carriage paid. Also ZOO, 85, £3, carriage paid. J. BAGULEY, Middle Hill, PENNSILVA, CORNWALL



—the 'REAL THING'  
in models!

Don't miss the newest "ASTRA" working models—they are high quality engineering jobs, strongly made and accurate in detail—the real thing in all but size! Good toy shops still get a limited supply.

### ASTRA WORKING MODELS INCLUDE . . .

Ack-ack, fort and anti-tank guns, Naval pom-poms, searchlights, conveyor systems, etc., etc.

## ASTRA PHAROS LTD

239, EARLS COURT ROAD, LONDON S.W.5

### BOOKS:

"Miniature Building Construction" . . . . . 8/6  
L.M.S.R. Loco. Ref. Book . . . . . 3/-  
"British Railway Stations" No. 2 . . . . . 3/-

### ELECTRIC MOTORS & STEAM ENGINES:

4 volt D.C. . . . . 12/6 6 volt A.C. . . . . 21/-  
6 volt Dynamo and Lamp . . . . . 21/-  
Steam Engines, Horizontal . . . . . 24/7, 36/5, etc.

### RAILWAY ACCESSORIES:

Coal Bunkers . . . . . 00 0  
Coal Offices . . . . . 1/3 1/6  
Single Seats with Timetable . . . . . 4/- 6/-  
Pea Lamps, Min. S.C., 5 v. . . . . 3/6 3/6  
Wood Station Buildings, 17 in. Platform . . . . . 6d.  
Modelcraft and Merco Building Lithos. Exley L.M.S. and G.W.R. Coaches in Stock.

Postage extra. "00" or "0" Parts List 3d. per post.

TYLDESLEY & HOLBROOK (M.E.T.A.)

109, DEANSGATE, MANCHESTER 3

IAN ALLAN LTD.

MAIL ORDER  
DEPT.



33, Knollys Road

STREATHAM  
S.W.16

### XMAS PRESENTS

Post free

The R.C.H. Maps of England, Wales and Scotland . . . 8/-  
Titled Trains of Great Britain (By C. J. Allen) . . . 8/-  
Trains Annual, 1948 . . . . . 8/-  
British Electric Trains (By N.W.R. Linecar) . . . 5/4  
Schools Class (By S. C. Townroe) . . . . . 2/-  
Studies in Steam . . . 2/9 Titans of the Track:  
Trains Illus., No. 8 . . . 1/2 G.W.R. . . . . 1/8½  
A.B.C. G.W.R. Locos. 1/8½ S.R. . . . . 1/8½  
A.B.C. L.M.S. Locos. 2/2½ L.N.E.R. . . . . 1/2  
A.B.C. S.R. Locos. . . . . 1/8½ L.M.S. . . . . 2/2½  
A.B.C. L.N.E.R. Locos. 1/8½ Locomotive Engineers:  
Locovariety . . . . . 1/2½ L.N.E.R. . . . . 3/3  
Locollection . . . . . 1/2½ G.W. . . . . 1/8½  
Golden Arrow . . . . . 1/8½ S.R. . . . . 3/9  
L.B.S.C. Locomotives 3/9 World's Smallest Rly. 2/9  
S.E. & C.R. Locos. . . . . 3/9 Jig-Saw Puzzles . . . 2/6  
Southern Locomotive Spotting Chart . . . . . 1/5



## STAMP ADVERTISEMENTS

(See also pages 496 and 498)



**MINT PEACE SETS.** Aden 9d., Ascension 1/-, Australia 1/2, Br. Solomon Is. 7d., Burma 1/3, Ceylon 1s. 9d., Ceylon 8d., Falkland Is. 9d., Falkland Is. Dep. 1/-, Fiji 10d., Gilbert & Ellice Is. 7d., India 2/9, Mauritius 9d., N. Zealand 5/-, N.Z. Dep. (3) 4/9, Nyasaland 6d., Pitcairn Is. 10d., St. Helena 1/-, Seychelles 1/2, Trinidad 9d.

**GENERAL OFFERS.** ROYAL VISIT ISSUES FOR BASUTOLAND, Bechuanaland, Swaziland, S.A., S.W.A. and S. Rhodesia 10/-; Brunei 1947, 1, 2, 3, 5, 6, 8, 10, 15, 25, 30, 50c, 4/4, s1 2/9; Australia 1940 3d. (186) 7/6; and S. Rhodesia 10/-; Brunei 1947, 1, 2, 3, 5, 6, 8, 10, 15, 1941 3 provs. 2/6; 1945 Duke of Gloucester 1/6; 1946 Mitchell 1/6; Austria Vienna Fair (8) 1/-.

STAMPED ADDRESSED ENVELOPE REQUIRED FOR ALL SENDINGS (S.A.E.). 10% NEW ISSUE SERVICE. BULLETIN NEW ISSUES, ETC., 1d. ILLUSTRATED LIST CHEAP SETS 1d. and 1d. S.A.E.

**T. H. SMITH** (Letts & Co.) Established 1920  
65, ST. KILDA ROAD, LONDON W.13

**"A HISTORY OF HIGHLAND LOCOMOTIVES"**

By M. C. V. ALLCHIN 10/6 Post Free  
Listing every Highland locomotive from the earliest constituent companies onwards. Class dimensions, building dates, works numbers, detailed yearly summaries, renaming and renumbering together with interesting notes. Stock lists in full for the years 1865, 1922 and 1947, those for intermediate years readily derived. Officially checked by courtesy of the L.M.S.R. Over 100 illustrations, with many line drawings especially for model enthusiasts.

Railway Hobbies Ltd., 86, Essex Rd., Southsea, Hants.

**SCHOOLBOY'S OWN EXHIBITION**

1st to 10th JANUARY, 1948

See **STAND No. 30**, New Horticultural Hall, Westminster, S.W.1., for a display of cigarette cards from the finest stock in the world. Send 2d. for list of special bargains available by post and at Exhibition.

**THE LONDON CIGARETTE CARD CO. LTD., Box M 30**, Wellesley Road, Chiswick, London W.4

**WILMSLOW MODEL COMPANY**  
WATER LANE, WILMSLOW, CHESHIRE

Your mail order by return of post.

We have a tip-top selection of model railway and aircraft kits and accessories. Railway kits in "00" and "0" gauges. Trix constructional sets. Diesel and Petrol Engines. Wilson Lorries. The largest stock of aircraft accessories in the North. Send 3d. stamp for new comprehensive 8-page 1948 list.

**"POWER POTENTIAL"**

Studies of Locomotives at Rest

Price 25s. 0d post free

A volume of twelve magnificent pencil studies of locomotives, with notes of interest on each. Send for your copy now; or for fuller details, send penny-stamped addressed envelope marked X in top left corner (no letter needed).

**E. RANKINE GRAY**

691 CHRISTCHURCH RD. BOSCOMBE, BOURNEMOUTH

**SPECIAL CHRISTMAS OFFER**

New Zealand 1947 Comp. M. . . . .	12/-
Norfolk Island Comp. M. . . . .	6/3
Norfolk Island Comp U.F.D.C. . . . .	7/6
New Zealand 1947 Health M. . . . .	6d.
New Zealand 1947 Health U. . . . .	9d.
Australia Newcastle M. . . . .	1/2
Australia Newcastle U. . . . .	1/7

Apex Album, 50 leaves . . . . .	4/11
Apex Album, 100 leaves . . . . .	7/11

Full range of Mint Br. Colonials in stock including all Commemoratives.

All items post free over 2/-. Send for our List to-day.

**WILLIAM GOODE (Retail) LTD.**

19, CLIFTON ROAD, RUGBY

**STUDY AT HOME FOR MATRICULATION**

Wolsey Hall (Est. 1894) will coach you by post for London Matric; School Cert., Engin. Prelim., Lond. B.Sc., Degree, Teachers' exams, etc. Tuition continued free if you fail; low fees, instalments. **PROSPECTUS FREE** from Director of Studies, Dept. GK1,

**WOLSEY HALL, OXFORD****BUILD YOUR OWN RAILWAY AND SHIP MODELS FROM ACCURATE "SKINLEY" BLUEPRINTS!**

We have hundreds of prints in stock, so send for our catalogues NOW!

RAILWAY DRAWING CATALOGUE . . . . 4d.  
SHIP DRAWING CATALOGUE . . . . . 4d.  
Both sent Post Paid.

JOHN E. SKINLEY, M.J.Inst.E.

132, High Street, SOUTHEND-ON-SEA, ESSEX

**CHEMISTRY APPARATUS**

Send Stamp for COMPLETE PRICE LIST

**SPECIAL OFFER:**  
Bunsen Burner  
Tripod & Useful  
Glassware  
12/6  
Post Paid

**BECK** (Scientific Dept. G), 60, High Street STOKES NEWINGTON, LONDON N.16

**SHORTHAND in One Week.** Test lesson 3d. DUTTONS (MO), 92, Gt. Russell Street, W.C.1

35 mm. films, All descriptions from 6/-, Baers, 176, Wardour St., London W.1. Hire Programmes 10/-.

★ Visit our Toy Fair—Third Floor ★

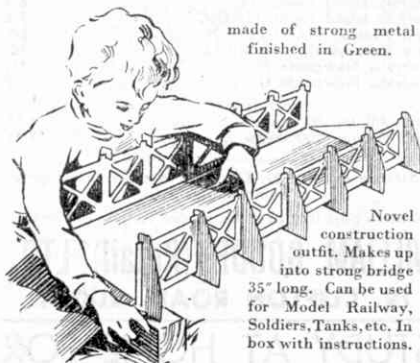
**BECKLIN BRIDGE**made of strong metal  
finished in Green.

Novel construction outfit. Makes up into strong bridge 35" long. Can be used for Model Railway, Soldiers, Tanks, etc. In box with instructions.

PRICE  
**12/10**  
Post &  
Pkg. 9d.

**Selfridges**

Toys: Third Floor.

SELFRIDGES LTD., LONDON, W.1 MAYfair 1234

**BINDING THE "M.M."**

Binding cases for the 1947 "M.M." can be obtained from Messrs. O. H. Bateman and Co., 23, Hanover Street, Liverpool 1. They are supplied in what is known as Quarter Basil, full cloth, and are tastefully embossed in gold with the name "Meccano Magazine." On the back is the name and volume number. Price 7/6 post free.

The binding cases are supplied so that readers can have their Magazines bound locally, but where desired the firm mentioned above will bind the twelve issues of the 1947 "Meccano Magazine" at a charge of 12/6, including the cost of the binding and also return carriage. The covers of the Magazines may be included or omitted, as required.

These prices apply also to the volumes from 1942 to 1946 inclusive.

Binding cases for the larger size of the "M.M." prior to 1942 are still available, price 7/3 for 12 issues. The complete cost of binding this issue is 15/- for 12 copies.

**MECCANO MAGAZINE**

Registered at the G.P.O., London, for transmission by Canadian Magazine Post.

EDITORIAL AND ADVERTISING OFFICES:

LIVERPOOL 13, ENGLAND.

Telegrams: "Meccano, Liverpool."

Readers' Sales and Wants. Private advertisements (i.e., not trade) are charged 1d. per word, minimum 1/-. Cash with order. Readers' advertisements are published as soon as possible; inclusion in the first issue after receiving them cannot be guaranteed.

**READERS' SALES AND WANTS SALES**

Hornby Electric Gauge 0 Railway. Send stamped envelope for details. Excellent condition.—Eggington, 135, Whitehill Road, Ellistown, Leicester.

Bowman model Steam Locomotive, gauge 0, 4-4-0, with Tender, in L.M.S. Passenger colours, packed in original boxes; running well. Complete £5.—Rowat, Firth View, Rosemarkie, Ross-shire.

Minibrix-Rubber Building Bricks; unbreakable and washable; over 1,000 parts including Windows, Roofs, etc.; 7 guineas or best offer.—Mather, Aubrey House, Queen's Road, Aberystwyth.

Dublo Locomotives, Track, Points, Rolling Stock, Accessories. Send for list.—R. Harris, 93, Lenton Boulevard, Nottingham.

Large Meccano Outfit valued £17. Would exchange for Hornby Gauge 0 Electric Railway in good condition.—35, Woodville Road, New Barnet, Herts.

"Meccano Magazines," good condition, January 1946 to June 1947, except March 1947. Also "Boy's Own Paper," February 1946 to August 1947. Offers.—Dobbie, 17, Gordon Terrace, Edinburgh.

Hornby Dublo Railway, comprising *Sir Nigel Gresley*, Two Tank Engines (one with scale wheels), Nine Coaches, Thirteen Trucks, Eight Points and over Fifty Rails, Controller, etc.; in perfect condition. £35.—Collins, 17, South Close, Mersham, Redhill, Surrey.

160 "Flights," May 1943–October 1946. Sell separately or complete. What offers?—Hewes, 17, Gloucester Road, New Barnet.

500 Stamps in Album 20/-; Headphones 6/-.—Ellis 15, Morris Road, Chelmsford.

Nearly 500 copies "Picture Post," from first issue to date; only one copy missing; excellent condition. Cost over £6; what offers?—Gibbs, 23, Darby Road, Liverpool 19.

**WANTS**

Dublo Electric Locomotives, Controllers, Transformers, Rolling Stock, Accessories. Good condition essential.—Fleming, 36, Morningside Park, Edinburgh.

Hornby Gauge 0 Points, Switches, etc.; few Trucks, Coaches.—Thornburn, Thordean, Pitheavlis Terrace, Perth.

Urgently. 100 Straight Rails and 10 to 20 Points of Hornby Clockwork Track.—J. R. Sanson, 8, Brook Street, Lancaster, Lancashire.

Bassett-Lowke 0 Gauge 3 ft. radius Electric Tinplate Track and Points; also Rolling Stock, Locomotive and Rectifier; good price given.—35, Wood Lane, London N.6. 'Phone Tudor 2823.

For invalid. Meccano Set; must be pre-war No. 10 and complete.—John Laurie, 86, Caledonia Road, S.S. Glasgow C.5.

**IMPORTANT NOTICE**

As this issue goes to press, increases in the rates of purchase tax are announced. The prices of goods advertised in this issue that are subject to purchase tax do not include these increases.

## THE MECCANO MAGAZINE

# HORNBY TRAINS



"Quick Dad—Points!"

## Loads of Fun

Every minute spent playing with Hornby Trains is brimful of thrills and enjoyment. Hornby Trains are strong-pulling, long-running, tested and guaranteed.

Prices of Hornby Gauge '0' Clockwork Train Sets from 17/6 to 52/- including tax.

Obtainable *ONLY*  
from Meccano Dealers



# MECCANO

## Engineering for Boys

Every boy is happiest when he is inventing, creating and constructing—that is why boys still find Meccano the most fascinating hobby in the world. There is nothing like it for young engineers who are keen on developing their own ideas.

Complete  
Outfits  
from  
**7/-**  
inc. Tax

MADE IN ENGLAND BY MECCANO LIMITED

THE MECCANO MAGAZINE

# HORNBY DUBLO

## ELECTRIC TRAINS

are here again!

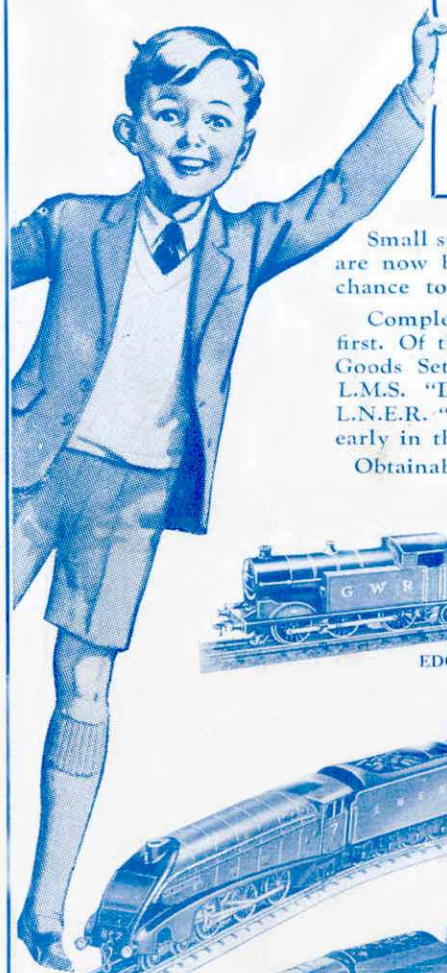

Small supplies of these long-awaited trains are now becoming available. Here is your chance to get the Perfect Table Railway.

Complete sets ONLY will be available at first. Of the sets illustrated below the Tank Goods Set will be ready this month. The L.M.S. "Duchess of Atholl" Set and the L.N.E.R. "Sir Nigel Gresley" Set will follow early in the New Year.

Obtainable only from Meccano Dealers.



EDG7 Tank Goods Set, L.N.E.R., L.M.S., G.W.R., S.R.  
Price 135/- (Including Tax)

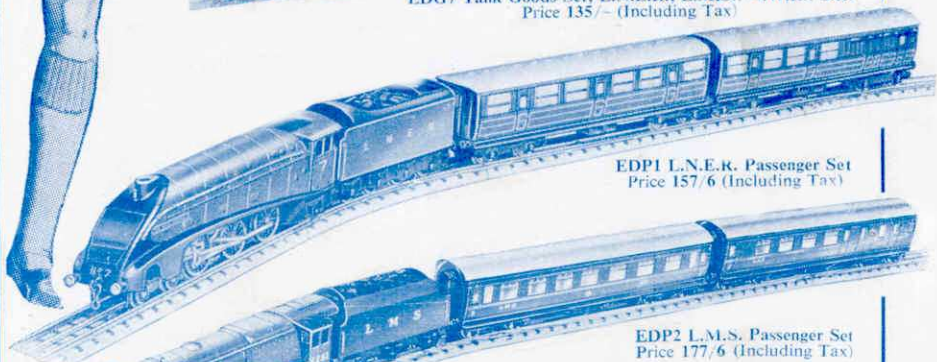

EDP1 L.N.E.R. Passenger Set  
Price 157/6 (Including Tax)

EDP2 L.M.S. Passenger Set  
Price 177/6 (Including Tax)

*Hornby-Dublo Trains are built to standard "00" Gauge. They are 12-volt Electric and power is obtained from A.C. mains through a Dublo Transformer and a Dublo Controller No. 1.*

**MADE IN ENGLAND BY MECCANO LIMITED**