

MECCANO

MAGAZINE



THE SHORT "SEALAND
IN BORNEO

9p

THE MECCANO MAGAZINE

DINKY TOYS

TRADE MARK REGD.

Look for next month's
announcement of a
NEW DINKY TOY



Seaplane
No. 63b
1/10



"Viking" Air Liner
No. 70c
2/2



Meteor Twin Jet Fighter
No. 70e
11d.



Avro "York" Air Liner
No. 70a
3/9



Tempest II Fighter
No. 70b
10d.

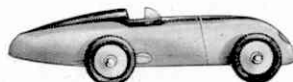

Small Open Racing Car
No. 23a
1/11

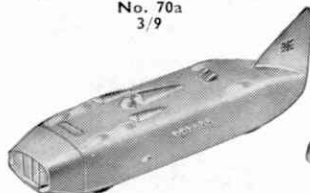

Streamlined Racing Car
No. 23s
2/9



"Speed of the Wind"
Record Car
No. 23e
2/5

Miniature Figures

These attractive miniature figures add the essential touch of realism to OO and O gauge railways and can also be used effectively with Dinky Toys vehicles.

GAUGE OO



No. 1001—Station Staff
Complete Set (6 pieces) 3/3



No. 1003—Passengers
Complete Set (6 pieces) 3/3

GAUGE O



No. 1—Station Staff
Complete Set (5 pieces) 4/8

No. 2—Farmyard Animals
Complete Set (6 pieces) 6/6

No. 3—Passengers
Complete Set (6 pieces) 5/3



No. 4—Engineering Staff
Complete Set (5 pieces) 4/8

No. 5—Train and Hotel Staff
Complete Set (5 pieces) 4/8

No. 6—Shepherd Set
Complete Set (6 pieces) 4/4

Prices include Purchase Tax

MADE IN ENGLAND BY MECCANO LIMITED

DINKY TOYS

TRADE MARK REGD.



Daimler Ambulance
No. 30h
3/5



Austin "Devon" Saloon
No. 40b
2/11



Ford "Fordor" Sedan
No. 139a
3/1



Hillman Minx Saloon
No. 40f
2/11



Triumph "1800" Saloon
No. 40b
2/11



Austin Taxi
No. 40h
3/10



Austin Wagon
No. 30j
2/11

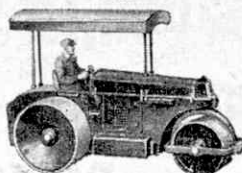

Aveling-Barford Diesel Roller
No. 25p
4/4



Fordson "Thames" Flat Truck
No. 30r
2/11

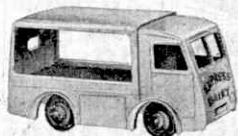

Electric Dairy Van
No. 30v
4/-



Tanker (Esso)
No. 30pb
3/4



Massey-Harris Tractor
No. 27a
4/8



Streamlined Fire Engine
No. 25h
2/11

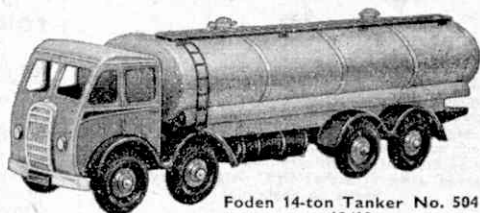

Foden 14-ton Tanker No. 504
10/10

Prices include Purchase Tax

Keep the wheels turning. Spare Tyres for Dinky Toys can be obtained from your dealer

MADE IN ENGLAND BY MECCANO LIMITED

It's a real thrill to build — a FIRE-STATION

ASK YOUR
DEALER FOR
DETAILS OF

BAYKO

REGISTERED TRADE MARK
the Original Plastic
BUILDING SETS

This Fire-Station is one of the numerous models that can be made with the No. 4 BAYKO Set

Made from richly coloured, high-grade plastic material, BAYKO is beautifully finished, easily cleaned and will survive years of hard treatment.

PRICES:

No. 0 ..	15/-
No. 1 ..	22/6
No. 2 ..	37/6
No. 3 ..	59/-
No. 4 ..	118/9
No. 0x ..	7/6
No. 1x ..	15/-
No. 2x ..	22/6
No. 3x ..	60/-



PLIMPTON ENGINEERING Co. Ltd.
GIBRALTAR ROW, LIVERPOOL 3

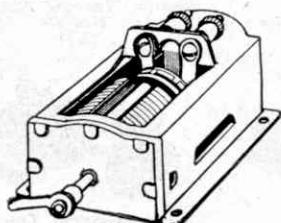

The "1461" Motor for MODEL POWER BOATS

An inexpensive, simplified but powerful electric unit for models up to 24 inches long. For use on dry batteries. 3 inches long, 1½ inches wide, 1½ inches high, weight 6 oz. For larger models, the "Marine" is a powerful permanent magnet unit, suitable for models up to 39 inches. Runs on dry batteries or accumulators. 3½ inches long, 3½ inches wide, 1½ inches high, weight 15 oz. Prices on application.

Write for full details and ask for "Model Ships List" (5/17), price 1/-, post paid.

BASSETT-LOWKE LTD.

Head Office and Works:

NORTHAMPTON

LONDON: 112, High Holborn, W.C.1
MANCHESTER: 28, Corporation Street



BOYS

THIS
IS
IT!



with

4 SUPERB THRILLING COWBOY DRAMAS

'New Frontier' | 'The Gallant Legion'

'The Plunderer' | 'Hostile Country'

NOT CARTOON : THE ACTUAL REAL FILM
FOWDEN FILMS OPTICAL SERVICE
2, HASTINGS STREET, LUTON, BEDS.

R.C.T.S. NEW PUBLICATIONS

"LOCOMOTIVES OF THE GREAT WESTERN RAILWAY"

Part Eleven, "The Rail Motor Vehicles and Internal Combustion Engines" gives complete particulars of all such vehicles of the G.W.R. and its constituent companies. Every type is illustrated. Price 3/6. Part One, "Preliminary Survey" is still available, price 10/-.

"LOCOMOTIVE STOCK BOOK 1952"

setting out full classified lists of the locomotive stocks of all railways in Great Britain as at 31/12/51, together with statistical analysis and stock alterations for 1950/1. All classes that became extinct are illustrated. All items post free from Price 10/-.

Hon. Publications Officer

18 Holland Avenue, Cheam, Surrey

BRYLCREEM

for successful grooming

Successful men use Brylcreem because they know smartness pays—handsomely. Only Brylcreem keeps the hair perfectly groomed all day. Only Brylcreem gives that confident, disciplined smartness that is the hall-mark of success. And remember—your personal appearance demands the best, such as only Brylcreem can give. Ask for Brylcreem always—it's the perfect hairdressing. Tubes 1/8, 2/6, and large economy size 4/6. Handy tubes 2/6.



BRYLCREEM
THE PERFECT
HAIRDRESSING



royds 72/38

P82



All the best bikes come
from **CURRYS**

VISIT THE FINEST CYCLE
SHOW IN YOUR TOWN AT

Currys
LTD

Britain's Largest Cycle Distributors

RALEIGH · HERCULES · TRIUMPH · ROBIN HOOD
240 BRANCHES THROUGHOUT ENGLAND AND WALES

FREE! Write for wizard cycle folder in colour. Post coupon today (in unsealed envelope 14d. stamp) to: CURRYS LTD., 77, UXBRIDGE ROAD, EALING, W.5.

NAME

ADDRESS

M1

Block letters please



Brookbank

FOR FACES & PLACES

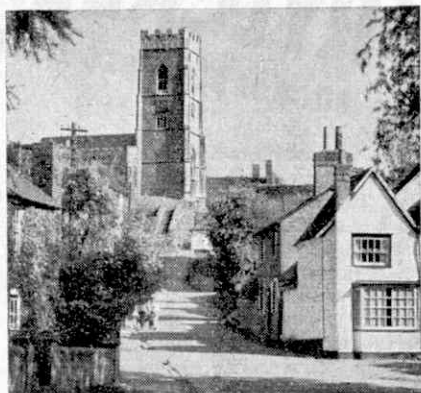

ILFORD SELOCHROME FILM



Foden

SCALE

MODEL LORRIES

You can dismantle them—just like the real thing!

FODEN TIPPER LORRY 65/-

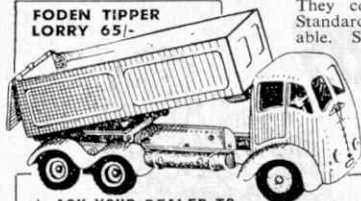

★ ASK YOUR DEALER TO SHOW YOU THESE WONDERFUL MODELS

They come ready assembled. Standardised parts—all replaceable. Shaft drive. Universal coupling. Ackermann-type steering. Floating rear bogie. Rubbertyres. Powerful Spring Drive.

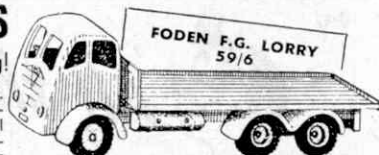

DYSON 8-TON TRAILER 18/6

Marketed by

Attaches to rear of either mechanical model!

ABBAY CORINTHIAN GAMES CO., London S.W.1

WHAT A SUPER GUN!

500 SHOTS AT ONE FILLING!

Thrilling news! Here's the water-repeating gun you've dreamed about! The "Invader" is a realistic sub-machine gun which "fires" powerful, accurate, long-range jets of water—500 shots at a filling! Beautifully made with full true-life details, the "Invader" is a sure-fire battle winner for you and your pals! Complete with "can't lose" filler cap—it's only 12/6. Order yours now!

Every reader is going to want an "Invader." So make sure you are the first of your gang to have one of these wonderful Commando-type guns.

ONLY
12/6

Post & packing
9d.

SIZE
17 in. LONG



SEND FOR THE 'INVADER'
WATER REPEATING
SUB-MACHINE GUN TO-DAY

Send 13/3 postal order or cheque for immediate delivery by post. Money refunded if not delighted.

W. D. MORGAN & CO. LTD.

Dept. M.11.7, 2, Gray's Inn Road, London W.C.1



A busy street scene with a difference! These are all models—but because they are true scale replicas of full-size vehicles they look REAL! They are TRI-ANG MINICS—the finest clockwork toys available. MINIC cars are precision built with all the features of the full-size vehicles they represent and are powered by strong clockwork motors. In brief, there is nothing to touch a MINIC model for realism and power.

As we do not supply direct, go along to your local MINIC dealer and ask to see the huge range of these wonderful models now available.

Manufactured by _____

LINES BROS. LTD., Merton, London S.W.19, England



You're right on target



4/11
no tax

with these wizard
'MERIT' Binoculars
and Jet Guns!

MERIT 'PATROL' BINOCULARS
Light-weight, fixed-focus Binoculars, ideal for all outdoor occasions. Optically perfect unbreakable lenses give clear vision for a great distance. Complete with lanyard, in attractive carton.



MERIT 'RAMBLER' BINOCULARS

All-plastic with unbreakable lenses. Individual eyepiece focusing and central hinge. Complete with lanyard. In attractive coloured carton.

6/11
no tax



12/6
inc. tax

Overall length 17 in.

MERIT 'INVADER' WATER MACHINE GUN

Exceptionally well-moulded hard-wearing plastic, this 500-shot repeating Sub-machine Gun will outshoot any other water gun.

MERIT 'JET' WATER PISTOL

A super Water Pistol firing 200 shots with one filling. Strongly moulded in a variety of bright colours.

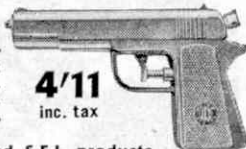

4/11
inc. tax

See **MERIT** and **S.E.L.** products at good dealers. Send p.c. for Illustrated List to

J. & L. RANDALL LTD

(Associated Company: **SIGNALLING EQUIPMENT LTD**)

(Dept. 3), Merit House, Potters Bar, Middlesex

GREAT NEWS!

Here's a Passenger Set that until recently was for **EXPORT ONLY!** If you want England's best—this is it—Terrific Value!

1. A hand-built 4-4-0 "0" Gauge Tender loco (outside cylinder) as used for main line traffic, fitted with our famous electric smoke apparatus (controlled by on/off switch) 12 volt D.C. consumption 1.5 amps.
2. Two Saloon and one Brake Compo. Coaches, absolutely fully detailed and painted true to type.
3. One oval of 3-rail track 3' 10" radius, overall size 9' 8" x 8' 2". **Price £24-4-0** (incl. P. Tax)
4. Presentation Case.

UNDOUBTEDLY THE FINEST BOXED RAILWAY PRODUCED IN THE WORLD TO-DAY

"0" Gauge Combined Manual and Catalogue, 100 pages. . . . **Price 2/6 post free.**

THE
LEEDS MODEL CO. LTD.
DEWSBURY ROAD, LEEDS 11
ENGLAND

Realism in Modelling

Cardboard is not a makeshift material with which to work; suitable card correctly treated gives great strength, long life and perfect detail. These qualities make it the ideal material for the building of goods vehicles, and no modeller can afford to be without our famous textbook:

"CARDBOARD ROLLING STOCK AND HOW TO BUILD IT"

Price 3/6 (by post 3/9)

The 45 pages of clear instructions, diagrams and photographs show how easily a perfect and fully detailed wagon or van can be built.

For details of ERG "Precision" Card Parts and the fine range of 00 fittings and accessories available to all railway modellers see:

THE ERG CATALOGUE AND MANUAL

Price 3/6 (by post 3/10)

For every railway modeller's library—**"A STUDY OF THE MODEL RAILWAY"**

Price 3/6 (by post 3/9)

The fascinating textbook that gives a new insight into the hobby.

ERG
(BOURNEMOUTH) LTD

The Leading 00
Trade Supply Firm
529
ROUMELIA LANE
BOSCOMBE
BOURNEMOUTH

Keep your eye on Halfords

... and be sure of the finest selection of spares, accessories and equipment, including a full range of "Halford" "Raleigh" and "Robin Hood" Cycles—there's a Halford's branch in every large town.



**THE HALFORD
CYCLE COMPANY LIMITED**

HEAD OFFICE

239 CORPORATION STREET
BIRMINGHAM 4.

BRANCHES IN ENGLAND, SCOTLAND AND WALES

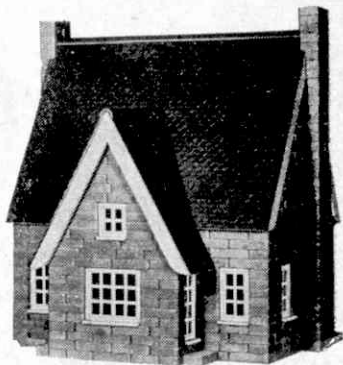

YOU can build this INN

WITH

BRICKPLAYER

BRICK & MORTAR
BUILDING KIT

It enables you to build Garages, Houses, Railway Stations, Signal Boxes, or from your own imagination. All railway models will fit 'O' gauge scale. Buildings can be permanent, or dismantled by merely soaking in water and the bricks used again and again.

BRICKPLAYER KITS AT 28/6 AND 52/6 ARE AVAILABLE FROM GOOD TOYSHOPS, HOBBY SHOPS AND DEPARTMENTAL STORES

ACCESSORY PACKS

No.	Contents	Price
100	100 Full-size Bricks	3/-
101	52 $\frac{3}{4}$ -Bricks and 72 $\frac{1}{4}$ -Bricks	3/-
102	Gable and Peak Bricks	3/-
111	Capping and Roof Tiling	2/6
112	Concrete Roofing	2/6
114	Bag of Brickplayer Cement	1/3
115	Roofing Cement	9d.
8107	2 Bay Windows with 31 Splay Bricks	3/9

METAL OR PLASTIC WINDOW AND DOOR FRAMES

	F1	F2	F3	F4	F6	F8	F10
	8½d.	6½d.	7½d.	5d.	4d.	6d.	7½d.
8108	Sheets of Glazing, 1½ in. x 6 in. (Plastic) 1½d.						

If your dealer cannot supply, write for address of nearest stockist to:

J. W. SPEAR & SONS LTD.
DEPT. M • ENFIELD • MIDDLESEX

The Best Bike a boy ever had!



**It's time
you had a**

BSA

EVERY lucky fellow who owns a B.S.A. Bicycle is agreed that it is absolutely the best bike a boy could possibly have. It is light yet extremely strong. It is smart looking, smooth-running and completely reliable.

Saddle and handlebars can easily be adjusted to fit you as you get taller. A B.S.A. Bicycle will speed you to school, to the pictures or out on spins with your friends.

Would you like to know more about these wonderful bicycles?

To B.S.A. Cycles Ltd., 31, Armoury Road, Birmingham, 11. Please send Cycle Catalogue.

Name.....

Address.....

POST THIS COUPON NOW

Post in unsealed envelope with 1½d. stamp.

Next Month: "THAMES PLEASURE STEAMERS." By A. Nettleton

MECCANO MAGAZINE

Editorial Office:
Binns Road
Liverpool 13
England.

Vol. XXXVII
No. 7
July 1952

Britain's Grand Prix Challenger

I have just been reading the story of the Albi Grand Prix, in which two B.R.M. cars took part. They did not win, but in spite of that their performance was a real achievement and full of promise for the future. One of them, driven by

World Champion Juan Fangio, of Argentina, led the field for nearly half the race before engine trouble ended his effort; Fangio's countryman Froilan Gonzalez only completed five laps in the other, but had the distinction of creating a record by lapping the Albi track at 106.9

m.p.h. After the race Fangio said that his car was going magnificently and that he seemed all set to win.

It is quite clear that the B.R.M. is tremendously speedy; probably it is faster than any car of its class yet produced. It met more bad luck in the Ulster Trophy Race, but Fangio still considers it the best Formula I car ever made, and readers will join me in the hope that in other events to be decided after these words appear in print its

drivers and designers will reap the reward of their great efforts.

The driving force behind this British Grand Prix racing car is Raymond Mays, who in a long and interesting career achieved fame on the racing track,

particularly with the E.R.A. car, and in hill climbs such as that at Shelsley Walsh, which call for the utmost driving skill and precision if records are to be made. With him the team of B.R.M. designers, headed by Peter Berthon, have produced a car with many striking and original features,

including a new and remarkably powerful Girling brake of the disc type.

Readers will learn something of what the designers of the B.R.M. have accomplished from a splendid article that Raymond Mays himself contributes to the August issue of the "M.M." Do not miss this on any account.

The Editor

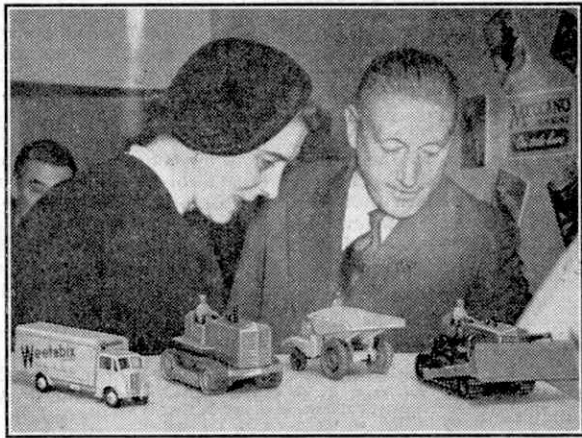

H.R.H. The Duchess of Kent inspects Dinky Toys forming part of the display of Meccano Ltd. at the British Industries Fair, Olympia, in May last. Her Royal Highness also showed great interest in the Meccano models and Hornby and Hornby-Dublo layouts on view, which were shown to her by Mr. R. G. Hornby, Chairman of Meccano Ltd.

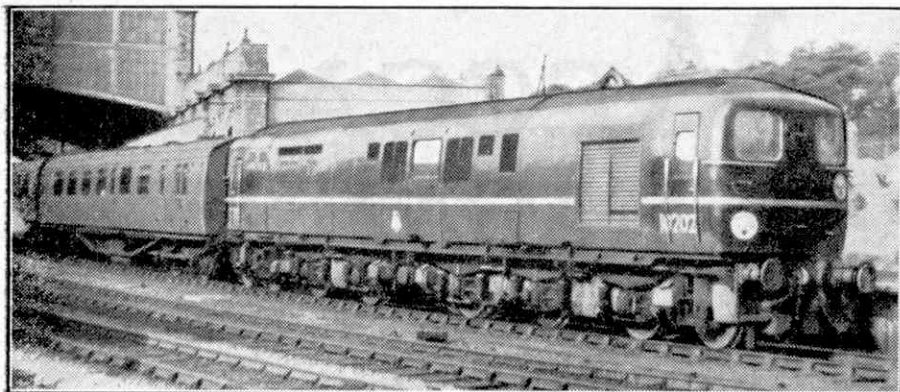

Riding a Southern Main Line Diesel

By S. C. Townroe, A.M.I.Mech.E.

THE Southern Region main line diesel-electric locomotive, No. 10201, was on show at the Festival of Britain last year, and I expect many "M.M." readers took the opportunity of inspecting it. The locomotive is of the 2-6-2 type, or "1 Co-Co 1." Its power unit is a 1,750 H.P. English Electric Company 16-cylinder diesel engine, and it has traction motors on each of its six driving axles. Altogether it weighs 135 tons, and its tractive effort is 31,200 lb. Both No. 10201 and the sister engine No. 10202 were built at Ashford Works.

While No. 10201 was still in the Festival, in September last year, No. 10202 was put into service on the Southern Region West of England line, working two round trips to Exeter every twenty-four hours, six days a week. This working included the night mail train from Waterloo to Exeter, and the fast 7.30 a.m. train from Exeter to London.

By April of this year, this engine had completed over 75,000 miles on these duties without any serious trouble. It had done the work of two steam locomotives daily, and in six months had run a mileage that a steam locomotive would not cover in less than eighteen months. The timekeeping was excellent and the drivers spoke highly of the comfort and ease of control.

The loads did not generally exceed 11 coaches on the West of England line during the Winter. As it was intended to use the second engine on the more heavily-loaded Bournemouth and Weymouth trains, commencing this Spring, there was some speculation whether the diesel-electrics would manage trains of 13 coaches on the fastest trains, such as "The Royal Wessex." I should explain that the gear ratios of the traction motors were designed for high-speed services, and not for the heaviest trains, so at present the gearing is on the high side.

I was delighted to have the opportunity of riding on No. 10201 on the first day it worked "The Royal Wessex," which leaves Waterloo at 4.35 p.m. and is allowed 55 minutes to pass Worting Junction, 51½ miles. With long stretches of gradient at 1 in 330 and speed restrictions in the London suburban area, the time allowance is not generous for a train exceeding 450 tons in total weight. The day was 1st April, and Driver Jack Attfield, of Bournemouth, was anxious that the engine should not make an April fool of him by dropping precious minutes, as he usually keeps time to the minute!

The engine was already nicely warmed up, as it had done a trip to Weymouth and back already since the early morning, and the fuel tanks had been filled with

The photograph at the head of the page, by G. O. P. Pearce, shows Southern diesel-electric No. 10202 at the head of the up 12.40 p.m. leaving Bournemouth Central for Waterloo. This picture was obtained on the first day of intensive working by a diesel-electric locomotive between Waterloo and Weymouth.

1,100 gallons of oil in readiness for another 270-mile trip. To supply the steam-heating boiler 880 gallons of water also had been taken on.

Sharp at 4.35 p.m. Driver Attfield got the "Right-away" and he brought the controller handle gently round to notch 3. The engine let forth a typical diesel roar as it took the weight of the thirteen coaches, and as we rounded the curves leaving Waterloo the ammeter needle on the control panel flickered momentarily, indicating that slight slipping was occurring at the driving wheels. A touch of the trigger to operate the air sanding gear corrected this.

Passing Queen's Road the speed had crept up to 45 m.p.h., but instead of the series of green colour-lights that we expected to see ahead, we were brought to a dead stand outside Clapham Junction, and then diverted to the local line. Evidently, something unusual had happened. As we passed Earlsfield we saw the culprit—a steam locomotive broken down in the section.

At Raynes Park the diversion lights told us that we were switching back to the main line again, which involved a reduction to 20 m.p.h. at the crossover. Consequently we were 5½ minutes down on schedule at Hampton Court Junction. Jack grimly told his fireman to "stoke up the fire" and held the controller handle to notch 8, the full power position, where it was to stay for the next 38 miles.

West Weybridge was passed at 68 m.p.h., but we did not reach that speed again until Farnborough, for the long rising gradient to milepost 31 brought our pace down to a minimum of 56 m.p.h. at the summit. Inspector Frank Thornton came through from the engine-room to the driving compartment to tell us that the engine was running sweetly at 750 r.p.m., at a comfortable temperature and with no signs of distress. In the cab we could hear little more than the rush of air beating against the windows, but with the engine-room door open we knew we were working on a "growler," as the Americans call their diesels!

Over the 14½ miles from Farnborough to Basingstoke our speed averaged 71 m.p.h. and when the signal box at Worting

Junction came in sight, we peered at our watches to see how far we were off schedule. Only three minutes late! So we had regained 2½ minutes on the most difficult part of the journey. At that rate we stood a chance of reaching our first stop, Winchester, on time, but we were baulked by a speed restriction of 15 m.p.h. at Waltham, where the permanent-way men had laid some new lengths of flat-bottom rail a few days before. For six miles we cruised at 80 m.p.h. until it was time to apply the brakes approaching Winchester, and we came to a stand two minutes behind time.

Starting from Winchester, the seven miles to Eastleigh were run in eight minutes and we reached the next stop, Southampton Central, in 15½ minutes against the 17 minutes allowed. Thus brought within three quarters of a minute of right time, we felt that the handicap of the unexpected delay at Clapham Junction had been overcome. Four minutes are allowed at Southampton. With a steam engine this is barely enough to take



Diesel-electric No. 10201, on which the author rode, nearing Eastleigh with a train from Weymouth to Waterloo.

sufficient water for Weymouth, but the diesel ignores wayside water-columns! At Brockenhurst, we were safely on time, but the awkward curve at that station is no easy place to start a long train and the control handle had to go to notch 6, causing the engine to emit an extra loud growl, before we moved. At Bournemouth Central eight coaches were detached and No. 10201 purred on toward Weymouth. We had timed "The Royal Wessex!"

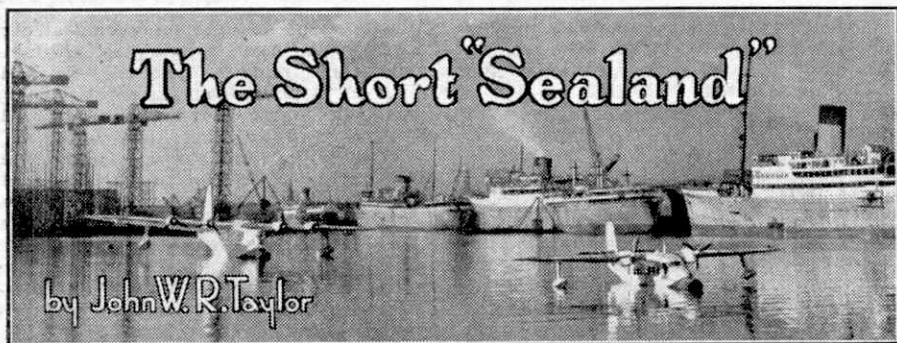

IF you think that present-day aviation has become an unromantic affair of big bombers and big business, the story of the little Short "Sealand" amphibian PK-CMA may soon make you change your mind. Its registration letters are significant, because it was owned by the Christian Missionary Alliance (C.M.A.), and PK is the national marking of the United States of Indonesia, where it was based.

The story began in America about two years ago, when C.M.A. officials were trying to find an aeroplane suitable for service in Borneo, as a link between civilisation and their outlying missions deep in the jungle. It was not easy, because Borneo is mountainous, tropical and covered with dense forest—certainly no place for an engine failure! Its only redeeming feature is that it contains many rivers, which are narrow and fast-flowing, but swept by steady winds that nearly always blow from the same direction, making it a typical "seaplane country." The missionaries had, in fact, been operating for some time an American-built aeroplane with interchangeable wheels and floats. But it was tedious work putting on and taking off the floats, and so supplies for the outstations were usually sent by native canoe, a process that often involved a three-months delay in arrival and 60 per cent. loss en route.

So the C.M.A. began searching for a small amphibian that could use either local airstrips or the rivers, whichever happened to be most convenient at any time. In the face of tough competition from American aircraft, they chose a

"Sealand." It was the first new British aeroplane sold in America after the war, and the first "Sealand" to enter service anywhere in the world.

PK-CMA was sent out to Djakarta by sea in a number of giant crates, and assembled by three men in 68 working hours. It soon proved its worth, delivering badly-needed food, supplies and mail to the most remote mission stations in two or three hours, in conditions that tested the aircraft's manoeuvrability as much as the skill of its "flying missionary" pilots. Thirty degree turns half-way down the take-off run, small rapids, sandbars, and sixty degree climbing turns between 6,000 ft. valley walls a few hundred yards wide were all in the day's work.

Then one day a bit of careless handling led to the "Sealand" being run on to half-submerged rocks in a river in the heart of the jungle. Several weeks elapsed before it could be patched up sufficiently for flight back to Djakarta for proper repair, and even then its troubles had only begun. On arrival, the pilot found Djakarta airport hidden under a monsoon squall; so he decided to fly around and wait for the storm to pass. Suddenly he noticed petrol pouring from both fuel tanks—the result of faulty maintenance or sabotage. Quickly and skilfully he put the aircraft down at the mouth of a convenient river, ran it up on to a sandbank and set out to find some help. He could hardly have chosen a worse spot to land, for the river separated two villages which were extremely hostile to each other and everyone else. No sooner had the pilot turned his back than the

Our cover this month, showing a Short "Sealand" amphibian in flight over a river in Borneo, is from an original oil painting and is reproduced by courtesy of Short Brothers and Harland Ltd., to whom we are also indebted for the picture at the head of the page. This shows a Short "Sealand" in Belfast Harbour.

inhabitants of both villages descended on the "Sealand" in force and looted it with such thoroughness and delight that it was soon not worth salvaging.

Fortunately, not all "Sealands" in service have to contend with such impossible odds. The two sold to Jugoslovenski-Aerotransport, for example, have a fairly peaceful if busy life carrying passengers on routes along the Dalmatian coast. Similarly, the ten "Sealands" ordered recently by the Indian Navy will be used for straightforward communications and crew training duties off India's Western seaboard at Cochin.

But the sturdiness and versatility of the "Sealand" make it an obvious choice for people who want to operate services in areas where conditions prevent the use of landplanes and floatplanes. Thus, the Norwegian company, Vestlandske Luftfartsselskap chose one of these little amphibians for operation between Bergen and Trondheim, up the rugged Norwegian coastline, where some of the world's worst weather is encountered. Take-off in a 20 knot crosswind is almost commonplace on this route, where every cloud and patch of mist seems to have a

mountain tucked inside it. Little wonder that V.L.S. pilots like the fine visibility from the "Sealand's" cockpit! The best practical testimony to its popularity is that the company may soon order another one to extend their services to Stavanger.

Much of the "Sealand's" popularity and efficiency undoubtedly result from the fact that it has behind it Short's 40 years' experience of marine aircraft construction. An amphibian is seldom easy to design, for it achieves its ability to use land, sea and air at the cost of combining the bulky fuselage of a flying boat with the weighty

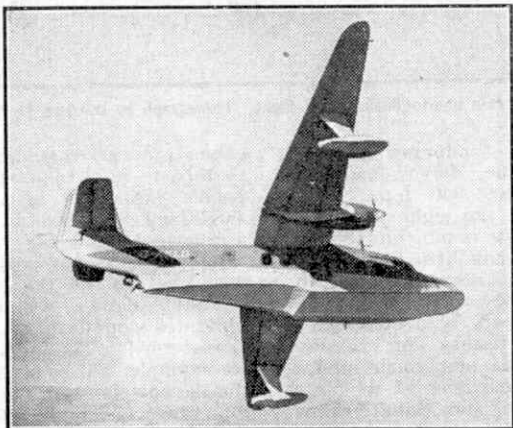

An almost overhead view of a "Sealand" in the air. Photograph by courtesy of "The Aeroplane."

undercarriage of a landplane. Aerodynamically and structurally it embodies the major encumbrances of both types, and the result could easily be an aeroplane with so much hull and undercarriage weight that its payload is negligible.

This is certainly not the case with the "Sealand," because although its wing span of 61 ft. 6 in. is 24 ft. greater than that of a "Meteor" it weighs only half as much as this single-seat jet fighter. Careful design and construction enable it to carry five passengers for 471 miles at a cruising speed of 161 m.p.h. on

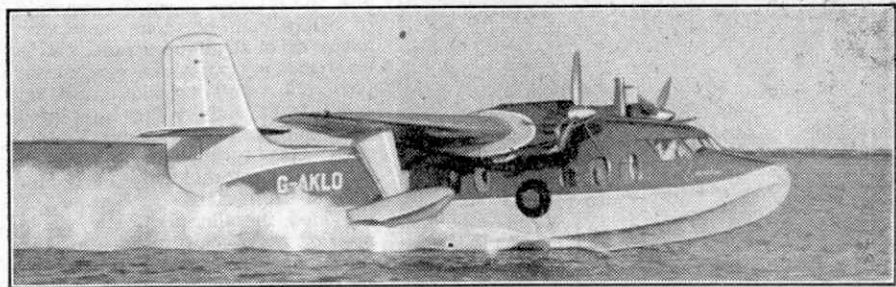

The "Sealand" amphibian taxiing on the water. Photograph by courtesy of "Flight."

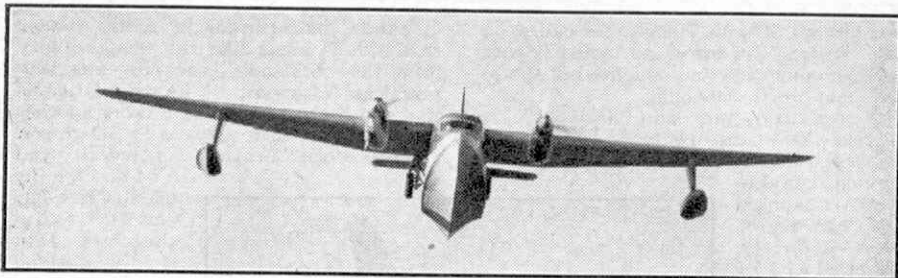

Front view of a Short "Sealand" in flight. Photograph by courtesy of "Flight."

105 gal. of petrol. Comparative figures for the excellent little "Dove" landplane, which also has two 340 h.p. "Gipsy Queen" 70 engines, are eight passengers for 500 miles at 179 m.p.h. on 130 gal. of fuel. They show how little Shorts have had to sacrifice performance for the "Sealand's" versatility.

Nor has performance been achieved at the expense of beauty or comfort. Externally, the little amphibian inherits the sturdy, handsome lines of its bigger brothers, the "Solent" and "Sandringham" air liners, which did so much to build up public confidence in the safety of flying boat travel. Inside the cabin there is the traditional roominess of a boat. The five-seat version has all the spaciousness of a large motor yacht, and even with eight passengers aboard there is plenty of room to move down the central gangway; while division of the hull into two separate

cabins prevents that unpleasant "piece of toothpaste in a tube" feeling that many people experience in air liners with a single long cabin. Add to this the high-wing arrangement and big windows, and the result is a perfect aircraft for the passenger who likes to see the world in comfort.

The "Sealand's" roominess offers almost unlimited scope as far as cabin arrangement is concerned. The Indian Navy's aircraft, for example, will be six-seaters fitted with dual control, and will carry special long-range fuel tanks and extensive radar and radio equipment. Another version has quickly-removable passenger seats, so that it can be converted speedily from an eight-passenger air liner into a freighter, or a mixed-traffic transport carrying, say, three passengers and a large quantity of miscellaneous cargo. Others have been designed as air ambulances, survey aircraft and even armed coastal patrol boats.

But the "Sealand" of which Shorts are most proud is probably "Nadia," recently supplied as the personal transport of H. E. Ahmed Abboud Pasha, of Egypt. His Excellency, who has widespread business interests throughout the Near and Far East, personally chose the furnishings and fabrics, and the result is a superb example of what can be done with the cabin of a small aeroplane. It is arranged to carry six passengers, plus pilot and co-pilot, and its cabin walls and ceilings are lined with turquoise blue natural hide, with dark turquoise silk damask curtains, embroidered in pink. Special anti-glare protection is provided for the pilot, the whole interior is air-conditioned, and the cabin is even fitted with a small cocktail bar and bookcase, to say nothing of

(Continued on page 334)

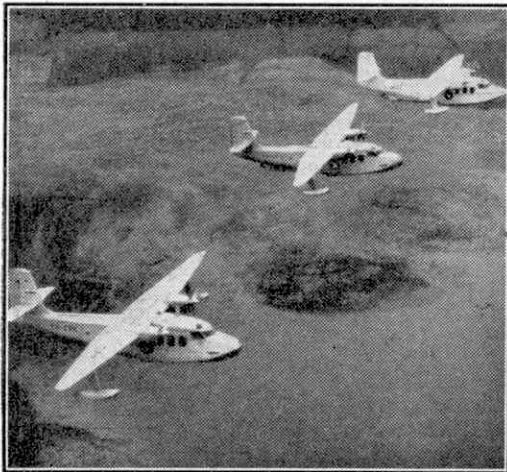

Two of these "Sealands" are on their way to Yugoslavia. Photograph by courtesy of Short Brothers and Harland Ltd.

A Training Centre with a Homely Touch

ALMOST every boy delights in making things, and this natural inclination is being turned to good account by the Dunlop Rubber Co. Ltd., in the Training Centre at their general rubber goods

a light, airy room with accommodation for 16 students—model dog kennels and rabbit hutches, so assembled that they can be easily taken to pieces, are used to show the boys how to "draw out" the

separate units from which the final assembly drawings are made. From preparing scale drawings of these homely objects it is a natural and easy step to purely engineering drawing.

Probably the most interesting room at the Centre is the engineering workshop, which is well equipped with shaping, milling and drilling machines, lathes, and so on. Here the boys are taught how to use tools and to make the dies and moulds used in the rubber workshop.

Their interest is held by allowing them to turn out such homely articles as pokers, ash trays and candlesticks, which they take home when they are well enough made. This spreads the interest further, the boys' parents too becoming actively interested in the Centre.

There is also a supervisory course at the Centre for boys who return to the company after their period of National Service.

factory, Cambridge Street, Manchester. The aim of the scheme is to give boys employed by the firm the knowledge and self-confidence necessary to become skilled workmen, and to work their way up to such responsible positions as that of charge-hand or foreman. Boys enter the Centre when they reach the age of 16 and attend one day a week until they are 18.

Their training is really practical throughout. For instance, at lectures on rubber and its production, each boy has samples of rubber on his desk, with the ingredients for a certain type of mixing, and later the boys mix the units on the model plant in the rubber workshop. Similarly, when dealing with cotton, so important to the rubber industry, the boys actually weave scarves of different colours and design on hand looms, and they are very proud to take their handiwork home as Christmas presents.

This natural liking for planning and making things is turned to practical account in other sections of the Training Centre. In the drawing office—

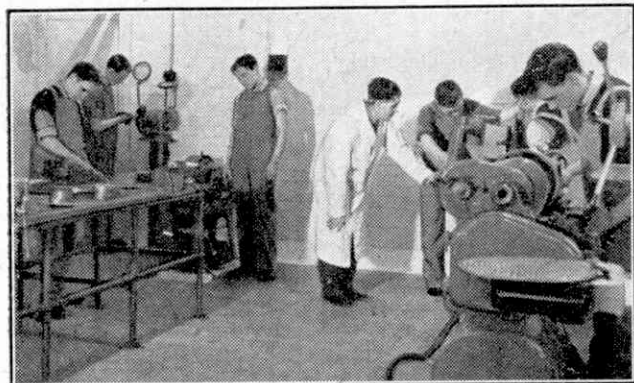

Boys receiving tuition in the Rubber Workshop at the Dunlop Training Centre, Manchester. Photographs by courtesy of the Dunlop Rubber Co. Ltd.

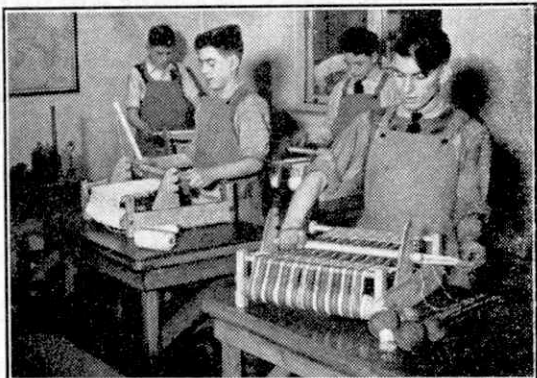

Weaving cotton scarves on wooden hand looms at the Centre. These make fine presents for the mothers and sisters of trainees.

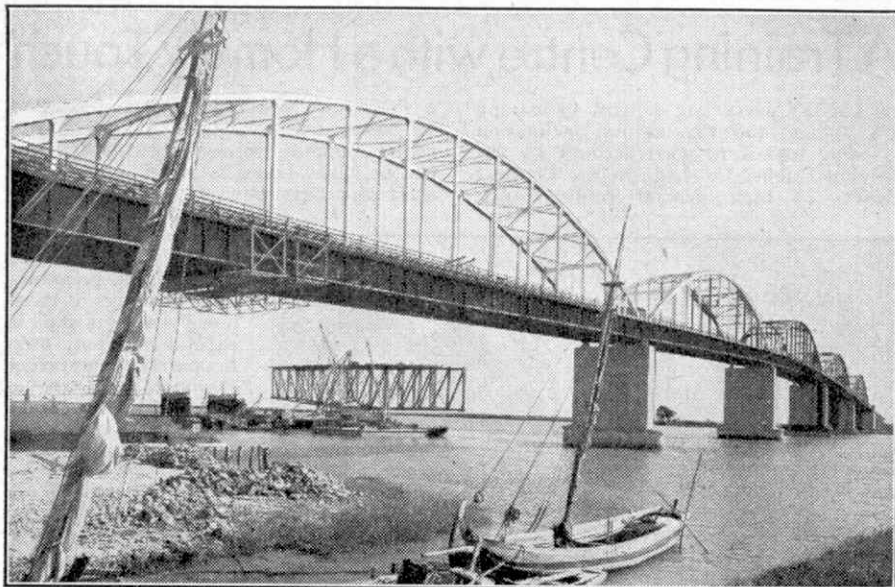

Portugal's Largest Bridge

The New Road Crossing of the River Tagus

WHAT is believed to be the largest bridge built in Europe since the end of the war was completed in Portugal in December of last year. It crosses the River Tagus about 12 miles upstream from Lisbon and will provide easier and speedier travel by road between the city and the part of Portugal that lies south of the river. Until it was built the nearest bridge was 50 miles up river from Lisbon, so that road traffic from the capital had to go a long way round in order to reach the southern areas of the country.

The Tagus is very wide at Lisbon, where indeed it opens out to form what may be described as a large lake. Even at Vila Franca de Xira, where the bridge has been erected, it is so wide that it has been necessary to build a bridge a little more than three quarters of a mile long. Of this length 770 yards is taken up by the approaches and almost 569 yards by the central

river spans, of which there are five, each of the same length.

Proposals to build a bridge across the Tagus near Lisbon had previously been made on several occasions, but had been abandoned because of the width of the river and also because of the difficulty of finding secure foundations. A suspension bridge at Vila Franca with a central span of 850 ft. was eventually suggested, but when tenders were asked for its construction it was found that it would be very costly. In the end a tender was accepted for the erection of a bridge of five arch spans.

The illustration at the head of the page gives a general view of the new road bridge across the Tagus at Vila Franca de Xira, 12 miles up river from Lisbon. This is the largest bridge in Portugal. The novel manner in which its five central steel arch spans were supported during erection is explained in the article on these pages. The steelwork of the bridge was erected by Dorman Long and Co. Ltd., to whom we are indebted for our illustrations.

This was submitted by Dorman Long and Co. Ltd., the famous British firm of bridge builders, in association with the Portuguese firm of Seth and working in close collaboration with two Danish contracting firms, both specialists in difficult marine foundation work. The approximate cost of the bridge to be erected was £1,250,000.

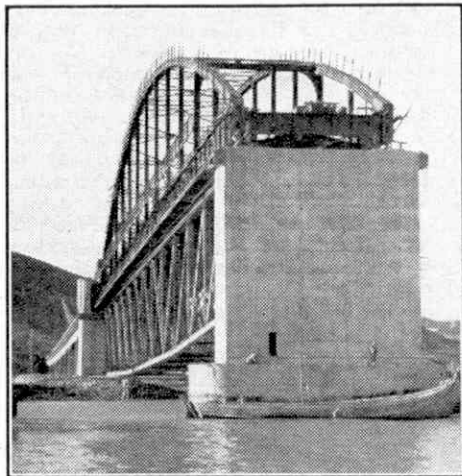

End view of the first arch span of the new bridge, showing one of the piers on which it rests.

The new bridge is the largest in Portugal and ranks as one of the great bridges of the Continent. It carries a roadway nearly 30 ft. in width, with two footways each about 4 ft. 6 in. across, and is designed for heavy highway traffic. The approaches are earth filled embankments from which at each end a section of reinforced concrete viaduct leads to the central section of five arches. The viaducts have spans of 65 ft. and 78 ft., and rest on concrete pile foundations.

Piling was used on a large scale, not only in providing the foundations for the approach spans, but also in erecting the six piers on which the five central river spans are carried. The reason for this is that the bed of the river consists of soft silt with a depth of almost 100 ft. Only at that depth is a layer of sand and gravel reached that provides a sufficiently firm foundation.

At the site of each river pier the silt was dredged out to a suitable depth and sand filling was

deposited in its place. The large hollow reinforced concrete piles were then driven from a floating staging, to rest on the sand and gravel layer, their upper ends being left projecting through the sand filling. Each of these piles is capable of supporting a load of 120 tons.

The next step in building each pier was to sink a caisson of reinforced concrete over the projecting tops of the piles to form its base. The caisson was built and launched in a floating dock that was specially constructed for the purpose. It was floated out to the position in which it was to rest, and there it was sunk over the tops of the piles by admitting water into it. The water was then forced from the working chamber by air pressure, and the space between its underside and the tops of the piles was filled solid with concrete, after which the caisson itself was filled with concrete and the pier shaft was built up to its full height.

Then followed the erection of the steelwork, just over 3,000 tons, of which about 57 per cent. is high tensile steel. The use of this reduces the total weight of metal required, always a great advantage in bridge building. The steel was supplied from the Dorman Long Works at Middlesbrough, and two of the spans were built there, the remaining three being fabricated by Braithwaite and Co. at West Bromwich.

The actual erection of the arches was carried out by Dorman Long and Co. Ltd. in a novel and spectacular way. It was

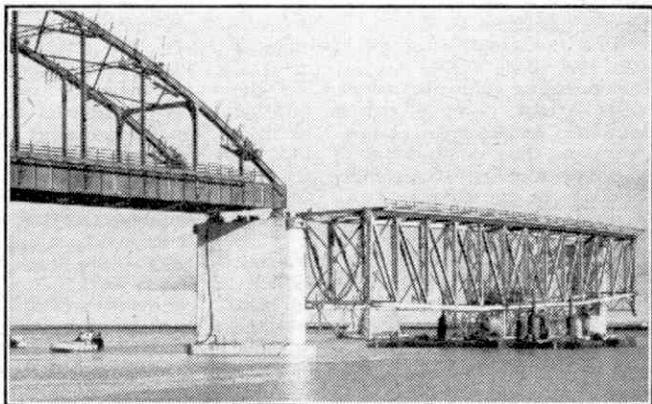

The service span used to support the steelwork of each span in turn during erection being warped into position between two piers.

impossible to put up scaffolding or falsework to support the spans during their erection because of the softness of the river bed and the great depth at which good ground could be found. The arches clearly could not be built in the same way as the spans of cantilever bridges, so in the end it was decided to build a special form of scaffold that could be floated into position to take the weight of each permanent span in turn while it was being built.

The scaffold took the form of a steel service span carried on two giant steel pontoons, each capable of supporting a weight of 500 tons. When this had been manoeuvred into position opposite the opening where the span was to be erected, moorings attached to the river bed and the adjacent piers were taken up and the whole outfit was warped into position between the piers. This was done at slack water at low tides. Enough water was then admitted to the pontoons to sink them sufficiently to land the ends of the service span on narrow shelves at the bases of the piers and to lower the pontoons themselves until they were clear of its underside. Then the pontoons were removed, leaving the service span in position.

After the erection of the permanent span the whole operation was reversed. The pontoons, already flooded to the fullest extent, were placed in position below the service span at low tide. The water was then pumped out of them, so that they rose to make contact with the underside of the service span, and then to lift it so that it could be taken out clear of the piers.

This erection scheme was carried out for each span in turn, working strictly to a timetable. Once the span had been floated into position and landed on the piers, packings of the necessary height were laid out on top of it, and the permanent steelwork was then assembled upon these by means of a 7½ ton locomotive crane. When the permanent span had been completed it was jacked up at each

end from the pier tops, the packings were removed and the span was then lowered on to its bearings on the piers.

These operations were complicated by the fact that while each span is of the same length, the height from the water to the underside of the steelwork varies throughout. The tidal range is up to 13 ft. at the site, which is subject to strong winds and tidal currents. The service span itself weighed 300 tons and had an overall length of 325 ft. The clearances between its ends and the bridge piers of course were necessarily small, and to manoeuvre it into position and land it

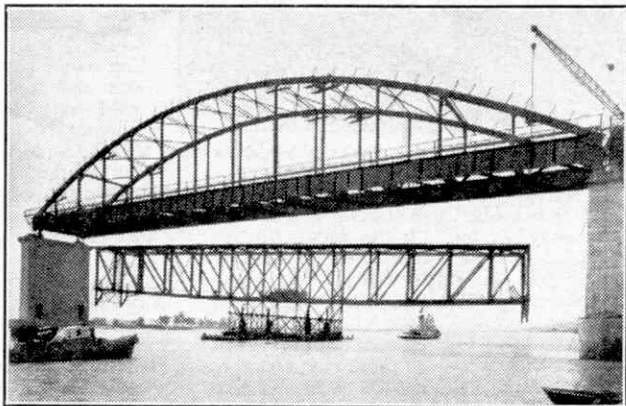

A completed span of the Vila Franca bridge. The service span used in its erection has been floated out in readiness to be placed in position for erecting the next main span.

precisely upon its bearings was a severe problem in navigation.

Conditions became even more difficult when the service span had to be removed from one opening for transfer to the next, for then the permanent steelwork had been completed above it and was resting on its jacks at the tops of the piers. Removal of the packings left just sufficient clearance between the underside of the permanent span and the top of the service span for the latter to be removed, but if there had been any delay in this operation on a rising tide the service span would have been trapped, with disastrous consequences.

An interesting feature was the preparation of the steelwork of the bridge for painting. It was blasted with sand and compressed air until the surface was perfectly clean and the priming coat of paint was applied within a few hours, followed by three further coats of paint.

The Festiniog "Toy Railway"

By E. V. Clayton

DURING a recent visit to North Wales I took the opportunity of visiting the Festiniog Railway, which is now closed. The track runs between the little harbour of Portmadoc and the slate quarries of the Festiniog region. From it magnificent views are obtained of the lovely scenery of that part of North Wales, and these justified the owners' recommendation to pre-war tourists to "Take a trip through Fairyland by Toy Railway."

The Festiniog was reputed to be the oldest small-gauge line in the world. It was first opened to traffic in 1836, with a gauge of only 1 ft. 11½ in., and in those far-off days it was only intended for the conveyance of slate. The track fell 700 ft. from Blaenau Festiniog to sea level, a total distance of 13 miles, with an average gradient of 1 in 92, and it was at first operated on the gravity principle. The long lines of laden trucks could coast easily down to the newly-built town and harbour of Portmadoc. The empties were later pulled back up the incline by horses.

Steam haulage began in 1863, when two 0-4-0 tank locomotives, with tenders as well, were acquired. These had driving wheels only 2 ft. 6 in. in diameter, and each engine weighed scarcely 7 tons, but soon four more locomotives were obtained, two of them being enlarged and weighing 10 tons each.

An important step was the introduction in 1869 of the "Fairlie" double-boiler type. A "Fairlie" engine presents a most unusual sight to anyone accustomed only to the orthodox type of locomotive. The cab is in the centre and a boiler complete with smoke-box, chimney and all the usual appurtenances projects both front and rear, so that one can never be sure which way the engine is really facing! This feeling is heightened by the fact

that each end of the engine is supported on a swivelling "bogie," each unit having its own set of driving wheels and cylinders.

A regular passenger service was started in 1865, but a speed limit of 12 m.p.h. was at first insisted upon. This was due to the hair-raising route the railway follows down from the mountains. The track twists and winds, often along the sides of considerable precipices, and crosses streams and gorges by high viaducts. As running on it was found to be safe and reliable the limit of speed was raised and the trains

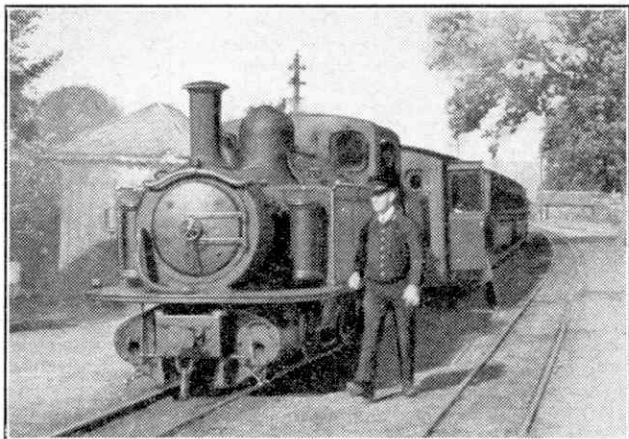

Right-hand running was the rule on the Festiniog line at passing loops. Here is one of the hard-working "Fairlie" double-boiler engines with a train. Photograph by C. F. Jones, Keynsham, Bristol.

often ran at up to 30-40 m.p.h.

As the slate traffic declined the Festiniog came to rely more on its tourist trade, but this was curtailed by the war.

The end came in 1946, when the line had to be closed, as owing to war-time conditions it had become unsafe. And so after 110 years traffic at last ceased to roll along the narrow gauge.

When I visited the Portmadoc terminal station the paint was peeling from signals and buildings and from the toy-like vans and wagons standing rusting in the grass-grown sidings. It was a sorry sight for any railway enthusiast. I was therefore glad to hear that there is a campaign afoot to re-open the line, if and when essential repairs can be effected.

Model Yacht Racing

How Championship Events are Run

By H. C. Hirst

THERE must be few of us who have not at some time or other stopped to watch small boys sailing all kinds of little craft on their local ponds. At times we have derived a certain amount of amusement from the progress, or otherwise, of their little boats. Given a light enough breeze, some of these small yachts will perform quite satisfactorily and make good progress over the water, but more often than not we see them in an almost horizontal position, with sails trailing in the water, being pushed around in circles by an unremitting wind. Yet there is always deep interest in the earnest endeavours of their owners to sail them.

From such small vessels to the lesser known model yachts that are entered for the British Open "A" Class Championship is a big step. The latter are perhaps not as well known as they should be. By comparison, they are real monsters, and the sport of sailing them calls for a technique all its own. A careful study must be made of prevailing wind strength and direction so that their sails may be set to obtain the maximum "push" from the wind, and on a course as near as possible to the one desired. This is the more necessary as no adjustments to the gear can be made once the boat is in mid-water, although of course the experts have a good idea of the course their boats

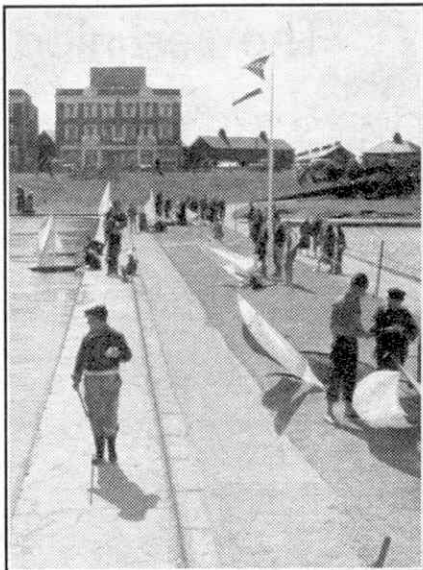

A model yacht race about to start at Fleetwood.

will take after they have been pushed off. I realised how much specialised skill was brought into play in sailing large model yachts when I saw the racing in the British Open "A" Class Championship at Fleetwood last year, and was introduced to the intricacies of the plan under which these races are run. The tournament system is used. In this the yachts race against each other in pairs, both ways of the lake, until each boat has met every other boat in the competition.

The uninitiated may be puzzled by such terms as "board," "run," "beat to windward," but these are easily understood on first explanation. One way of the lake is known as a "board," and when both ways of the lake have been sailed, this is called a heat. As the boats do not all sail together, a system has been adopted under which two points are awarded for a "run," that is sailing with the wind behind the yacht, and three points for a "beat to windward," that is against the wind. When



Preparing for the next "board," that is for sailing one way of the lake.

every boat has raced against every other in the competition, the points scored by each boat are totalled, and the winner is, of course, the one that has scored the most points in the competition. In the event of a tie for first place, a "board" is sailed to windward to decide the winner.

When a yacht is sailing on the beat and comes to the side, the competitor turns it about on the next tack by means of a pole of an authorised length. It is a tribute to the skill in design and trimming of sails, etc., of those concerned in their production and sailing that many of these boats when on the beat are capable of sailing to within three degrees of the wind. If a boat comes to the side on a run, it must be stopped and re-trimmed, and if two boats collide or foul they must re-sail that board.

Competition is very keen and spectators are usually asked to keep clear of the

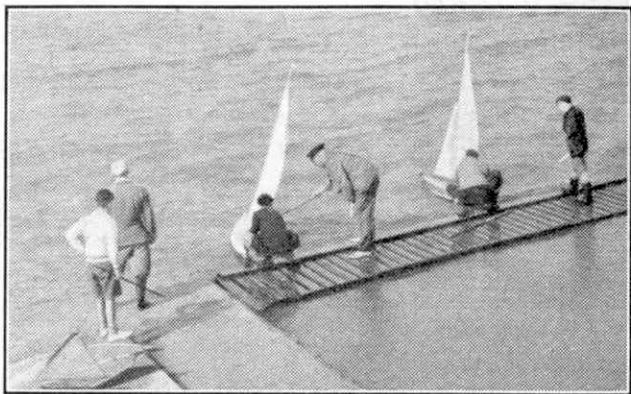

Ready for the "Off." Competitors with their boats in the water.

walks around the lake, so that no inconvenience is caused to the competitors in handling their craft and to avoid blanketing the sails.

The yachts that compete in the British Open "A" Class Championship are built in almost the same manner as a full-sized yacht. They are anything from six to seven feet long and weigh between 50 and 70 lb., and the length of mast may be up to eight feet. The average sail area of one of them is 1,650 sq. in.

The "A" Class Championship Cup was presented to the Model Yachting Association by its President, J. Herbert Scrutton, Esq., and is the most coveted trophy open to model yachtsmen. In 1950 the Association decided to make the race for this Cup an open event of international standing, and now many entries are received from the Continent as well as from all parts of the British Isles. In recent years, the event indeed has grown to such proportions that it is usual to admit only three boats from each affiliated club, in order to keep the entry list to a reasonable size.

The models entered in events of this kind, some of which are illustrated on these pages, are the elite of their kind, with their every detail designed and built with meticulous care, involving hundreds of hours of labour. Most of the yachts that compete in these Championship races have been built by their owners, who undoubtedly must have derived endless pleasure from watching the slow but steady growth of their models, culminating in the greatest thrill of all when their boat is launched on her first trials. They are splendid vessels, but smaller models too provide endless thrills and pleasure.

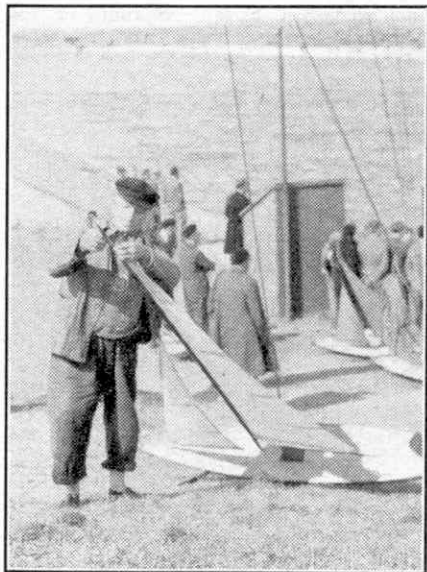

Final adjustments are made by a member of a French model yacht club competing at Fleetwood.



Lloyd's Bronze Medal.

Private Decorations For Heroism on Land and Sea

By Arthur Nettleton

WHEN Captain Kurt Carlsen received a silver medal from Lloyd's, for his valour in remaining aboard the disabled "Flying Enterprise" early

this year, the award was one of several decorations instituted by that well-known concern during its 250 years' history. Other bodies too have schemes for recognising bravery by presenting medals, and heroism has been rewarded in this "private" way on hundreds of occasions.

The silver medal awarded to Captain Carlsen was introduced in 1893, and is known officially as Lloyd's Medal for Meritorious Services. It is bestowed upon ships' officers and others who by extraordinary exertions have contributed to the preservation of vessels and cargoes from perils of all kinds.

It is not presented lightly, and in its 59 years' existence it has been awarded less than 420 times. Last year, indeed, this coveted decoration was gained only by one man. It was presented to Capt. F. R. Spurr for his skill in handling the British motor ship "Palana" when she towed another vessel 2,250 miles across the South Pacific. This feat was actually carried out in 1948, but three years elapsed before Lloyd's investigations were completed with the thoroughness that always precedes the presentation of such medals.

There is a bronze as well as a silver edition of this medal. Since June 1936 these have borne the Lloyd's coat-of-arms; from April 1913 until that time the medals bore a different design, and earlier still they were oval and not

circular as they are today. Originally, the decoration took the form of a star.

Lloyd's also have a much older award for saving life at sea. This medal was first made available in 1836, and is struck in gold, silver and bronze. It shows a scene from the Odyssey, depicting Ulysses being rescued from the perils of a storm by Leucothea.

This award has sometimes been won by members of ships' crews, as well as by skippers. It was conferred last year on the skipper, mate and four deckhands of the fishing trawler "Boston Fury," for their heroism in rescuing survivors from a shipwreck off the Norwegian coast in 1950.

Another medal, similarly struck in gold, silver and bronze, was introduced in 1913 in recognition of services to Lloyd's. The medallion shows Neptune in his chariot, but the reverse has the same design as the medal for meritorious services.



The Bronze Medal of the Royal Humane Society.



H.R.H. The Duchess of Kent, President of the Royal National Life-Boat Institution, presents the Gold Medal for gallantry to William Gammon, then coxswain of the Mumbles life-boat, at the Annual Meeting of the Institution in 1945.

The gold edition of this medal is perhaps the hardest of all the various Lloyd's medals to earn. So far it has been awarded only once, in 1921, when it was conferred upon Captain E. R. G. R. Evans—"Evans of the Broke"—for his gallant rescue of 220 lives from the French steamer "*Hong Moh*."

The newest Lloyd's decoration is a war medal first struck in 1940 for presentation to personnel of the Merchant Navy and Fishing Fleets in cases of exceptional gallantry at sea in wartime. The obverse depicts a figure symbolising courage and endurance looking out over the sea towards a distant merchant ship. The inscription is simply "Awarded by Lloyd's." The reverse shows a trident, symbolising sea power, surrounded by a wreath of oak leaves and acorns, and across the centre of the design is the single word "Bravery."

This highly prized medal has occasionally been conferred upon women. For instance, it was awarded to a stewardess of a ship sunk by enemy aircraft, who saved the lives of six passengers and swam for two hours supporting one of them until they were picked up.

Though this special medal was not introduced until World War II, as far back as the eighteenth century Lloyd's were recognising brave deeds performed in the face of attacks by enemy warships or privateers. The reward often took the form of a silver salver or a gift of one-hundred guineas. Swords of honour were also presented to naval officers for defending merchant ships, or destroying enemy vessels that preyed upon mercantile shipping. Lloyd's present-day list of medals thus has a long and historic background.

Among other bodies that reward heroism

in a semi-private way are the Royal National Life-Boat Institution, the Shipwrecked Fishermen and Mariners' Royal Benevolent Society, the Liverpool Shipwreck and Humane Society, and the Boy Scouts Association.

The fact that the R.N.L.I. issue medals is fairly well-known, but it is less widely realised that these have undergone revisions in comparatively recent years. The first medallions struck for the Institution, in 1825, showed the head of George IV, and this design remained until 1862. A likeness of Queen Victoria was then substituted, and subsequently busts of King Edward VII and King George V replaced this in turn.

No R. N. L. I. medals with the head of King George VI were minted, however, use of the Sovereign's effigy now being officially restricted to medals awarded personally by His Late Majesty. Instead the head of Lieut.-Col. Sir William Hillary, the founder of the Institution, is used.

The decorations made available by the Shipwrecked Fishermen and Mariners' Royal Benevolent Society were first

introduced about 1850. There is a gold and a silver medal, and these are of identical design. The gold one is awarded only for exceptional gallantry in rescuing crews from disabled ships. Well over 500 silver medals have been conferred by the Society, however, for bravery—slightly less conspicuous.

The Liverpool Shipwreck and Humane Society instituted their scheme of rewards in 1839 to honour the gallantry of seamen plying from Liverpool. Three types of medal, gold, silver and bronze, are available, but they are of the same design. The obverse shows a man being rescued from the sea while a boat approaches, and the inscription reads "*Lord save us,*

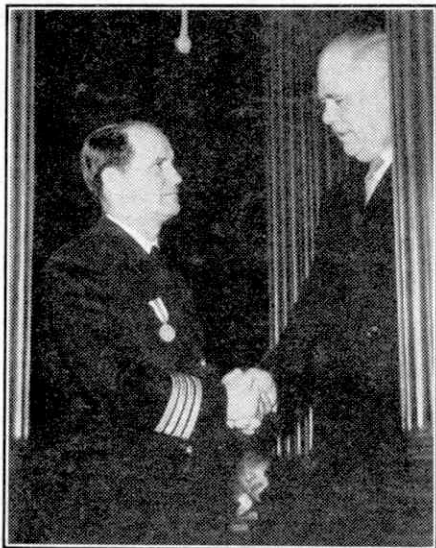

Mr. Matthew Drysdale, Chairman of Lloyd's, shaking hands with Captain Carlsen after presenting him with Lloyd's Silver Medal.

we perish." On the other side appear the civic arms of Liverpool.

A further medal, known as the Camp and Villavorde Medal, was struck by the



The design of the Liverpool Shipwreck and Humane Society's Silver Medal shows rescue work in progress.

the rescue of the passengers and crew of the Royal Mail Ship "Tweed," which was wrecked off the coast of Mexico in 1847.

The idea of striking a medal in honour of this brave deed was put forward at the time, but was not carried out until 1872. In general appearance the medallion resembles the Society's medal instituted in 1839, but the inscription is different.

Still another award offered by the L.S.H.S. dates from 1847, when the Society received a gift of £500 in railway stock, the income to be used for establishing a medal for saving life at sea. The gift was made by John Bramley Moore, and all the medals conferred under this scheme bear his name, though in other ways they are like the Camp and Villavorde Medal.

The Royal Humane Society offers silver and bronze medals, alike in appearance, for bravery in rescuing people from danger on land or at sea. The obverse shows a small boy blowing on an extinguished torch to see if a spark still remains. These medals are sometimes

presented even if the rescue attempt failed, the inscription "This award he has secured for saving a citizen" being changed to meet the altered circumstances in such instances.

These silver and bronze decorations of the R.H.S. are among the oldest of

for their kind, and for the Society's medal scheme was founded as far back as 1774. There is also a gold award of the same design, but this is known as the Stanhope Medal, and it was not introduced

until 1875. Only one of these gold medals is awarded each year; it goes to the person considered by the committee to have performed during the previous twelve months the bravest deed qualifying for the silver medal. The Stanhope Medal is then substituted.



The Nile Medal was presented by Nelson's prize agent at his own expense.



The Shipwrecked Fishermen and Mariners' Royal Benevolent Society's Silver Medal.

The Boy Scouts Association instituted gallantry awards for members of the movement as early as 1908, the range including the Cornwell Badge, and gilt, silver and bronze crosses. None of these are presented without very full investigations into the action concerned, but they have been won by Scouts all over the world. In Great Britain alone, more than 3,000 people owe their lives to Scouts who have saved them from drowning, fire, and other perils.

The Cornwell Badge, in memory of Jack Cornwell, V.C., is presented, in respect of pre-eminently high character and devotion to duty, together with great courage and endurance or gallantry. It was first awarded in 1916, when it was conferred on Patrol Leader Arthur Shepherd, of Middlesbrough, for assisting in the rescue of

(Continued on page 334)

BOOKS TO READ

Here we review books of interest and of use to readers of the "M.M." With certain exceptions, which will be indicated, these should be ordered through a bookseller.

"THE BEAUTY OF OLD TRAINS"

By HAMILTON ELLIS (Allen and Unwin, 20/-)

The author, well known for his previous railway books, remarks in his preface that the question of beauty in man-made things is a matter of purely personal opinion. With this in mind we are less concerned with our own views on this question, especially when these do not agree with those expressed in the book, than we are with our enjoyment of the way in which the author tells his tale.

Mr. Ellis sets down his early recollections and beliefs concerning trains in the great days of railway supremacy in land transport, to delight the present-day reader. He gives them to us along with entertaining stories of engines and trains, both in this country and abroad, and of their development from the crudities of the early days to the more finished products of the mid-Victorian period and the fine dignity of the days before 1914. A special section deals with what are termed "The Handmaids," in other words the suburban and local trains that are a familiar part of the daily round to so many of us. This is followed by fascinating treatment of the little railways, narrow gauge lines, and the local and industrial railways that once were so numerous. Finally there is a delightfully reminiscent account of the naming of locomotives, "a pleasing practice," as the author says, although there can be a great deal of controversy about individual and even class names.

The entertaining text of the book is well backed up by excellent reproductions of well-chosen photographs and eight illustrations in colour from the author's oil paintings.

"THE BOYS' BOOK OF CRICKET"

(Evans, 10/6)

This annual, now in its fourth season, is this year as informative and instructive as ever. It also provides good entertainment in the form of stories, quiz pages and crosswords, and as usual there are plenty of pictures, most of them reproductions of photographs of famous cricketers in action and of famous grounds.

The principal feature this year takes the form of a tribute to that fine cricketer Len Hutton, who last year joined the little group of batsmen who have scored a hundred centuries in first-class cricket. These historic centuries are listed, and there is an article by the great batsman himself, who gives some wonderfully good advice to those who have the ambition to follow in his footsteps. Other famous cricketers who contribute to the volume include Sir Donald Bradman, Alec Bedser, H. E. Dollery, Captain of last year's champions, and P. B. H. May, the amateur who started his Test Match career with a century against the South Africans at Leeds in 1950.

Club cricket and school cricket, cricket at home and overseas, the cricket of our Indian visitors—all these and many other topics connected with the game are well dealt with, and once more it can be said that here is a wealth of information and entertainment for any boy, or indeed anyone who is interested in the game.

"BRITAIN'S WEALTH IN INDUSTRY"

By HERBERT ARTHUR, M.Sc.
(Odhams, 2/- each)

Here are four booklets of a series designed to give a clear, accurate and non-technical account of the processes involved in our main industries. Much is made of pictorial presentation, and in each booklet the concise yet comprehensive description of the industry concerned is supplemented by a wealth of illustration, including detailed double-page drawings

showing an entire plant layout or a whole range of processes. There are also many other large sectional drawings and illustrations in half-tone.

"The Story of Coal" tells how coal layers and seams have formed over countless centuries from the decayed vegetation of pre-historic forests. It describes how mines are sunk, drained, ventilated and equipped, and the various methods employed to win the coal and get it to the surface. The distribution of coal and some of the many uses to which it is put in everyday life and industry also are mentioned.

"The Story of Iron and Steel" gives a simple and fascinating account of the layout and equipment of a modern steelworks.

"The Story of Shipbuilding" traces the work that goes into the construction of a modern ship, from blue-print to maiden voyage. An imaginary visit to a typical modern shipyard serves as a means of learning about the many different stages of the work carried out there.

Similarly "How Motor-Cars are Made" describes the work of a typical motor-car factory of today, from drawing the plans and making the components to the final assembly and the testing on the road.

At the end of each booklet is a short list of suggestions for readers who wish to make a more detailed study of the industry concerned.

"THE ABC OF CIVIL AIRCRAFT MARKINGS"

By JOHN W. R. TAYLOR
(Ian Allan, 2/6)

This is a new edition on the same lines as the previous one, published in 1950, but with a larger page size and correspondingly better illustrations.

The main part of the booklet contains a complete list, corrected to the time of going to press, of every civil aircraft in Great Britain, together with its owner or operator's name. The machines are listed in the alphabetical order of their registration letters. The remainder of the booklet deals similarly with foreign airline fleets, but lists only those machines serving the United Kingdom. Each list in this section is headed by the name of the country and a reproduction of the insignia of the airline concerned.

The booklet will be mainly of interest to readers who live near airports and aerodromes, or frequently visit them, and thus have opportunities of noting the registration letters of civil aircraft.

"LOCOMOTIVES OF THE GREAT WESTERN RAILWAY"

Part Eleven
(R.C.T.S. 3/6)

The present book forms Part Eleven of the R.C.T.S. series of booklets dealing with the locomotives of the Great Western Railway. It follows Part One, a preliminary survey reviewed in the "M.M." for September 1951, as for various reasons the parts are not necessarily being published in numerical sequence.

Rail motor vehicles and internal combustion locomotives are the subjects of this part. Details are given of the G.W.R.'s steam railcars and the auto trains that ousted them, various rail motors of the combined engine-and-coach type, and petrol-engine railcars, diesel shunters and the recent Gas Turbine locomotives. The illustrations include every type of vehicle referred to and they form a unique and attractive record.

Copies of the booklet are available at 3/6 each, including postage, from Mr. D. H. Wakely, 18, Holland Avenue, Cheam, Surrey. A special supplement also is now available free to those who have Part One, who can obtain copies of it from Mr. Wakely on sending a stamped addressed envelope.

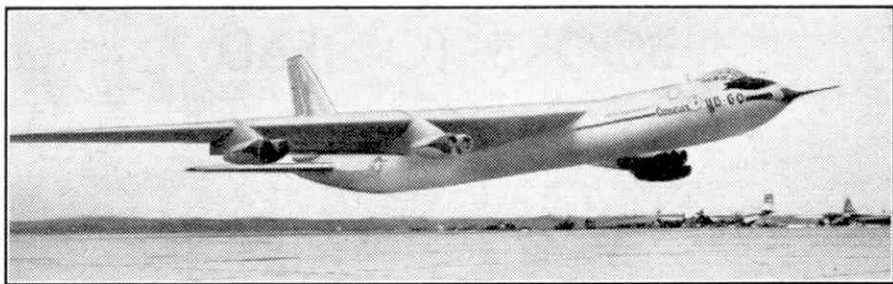

Convair's new YB-60 eight-jet bomber taking off on its first test flight. Photograph by courtesy of Consolidated Vultee Aircraft Corporation, U.S.A.

Air News

By John W. R. Taylor

New U.S. Eight-Jet Bomber

The fine photograph above shows the new Convair YB-60 taking off on its first flight, on 18th April last. This machine is the long-awaited jet-powered, sweptwing development of America's giant B-36 atom-bomber. Details of its equipment and performance are still top secret, but its eight Pratt and Whitney J-57 turbojets should put it easily in the over-600 m.p.h. class; while the fact that it stayed up for 1 hr. 6 min. on its first flight pays early tribute to its handling qualities. It is now being evaluated for the U.S.A.F. in competition with Boeing's new eight-jet YB-52.

Doubling "Comet" Production

News that de Havilland "Comets" are to be built by Short Brothers and Harland at Belfast means that production of these fine jet air liners will in time be doubled. At the moment, "Comet" orders total less than 50; but the first Short-built aircraft will not be completed until 1954, by which time the Royal Air Force will probably have decided to adopt the "Avon"-powered version as its standard high-speed aircrew transport.

A Neat Czech 3-Seater

One of the neatest and most popular products of the Czechoslovak National Aircraft Works is the little Zlin 22 "Junak" 2-3 seat light plane shown in the lower illustration on this page. It is built largely of wood, which helps to explain its high cruising speed of 100 m.p.h. on only 75 h.p., with a full load of three passengers and luggage. Its engine is of the Praga D four-cylinder, horizontally-opposed type; it has a span of 34 ft. 9 in. and loaded weight of 1,456 lb. Cruising range is 740 miles with two passengers or 400 miles with full load, and it does about 27 miles to the gallon of petrol.

Big Wind Tunnel for British Aircraft Research

Eleven leading British aircraft companies have formed an Aircraft Research Association to design, build

and operate a new wind tunnel able to test aircraft models at trans-sonic and supersonic speeds. Lack of such a tunnel has long hampered aircraft research and development. When completed, it will be the largest wind tunnel in the country and will require some 35,000 h.p. to drive its giant propeller.

Air-Cooled Jet Blades

Much more powerful jet engines may be possible as a result of research now being made in the design of hollow air-cooled turbine blades, and the blades may use a smaller proportion of scarce, strategically-important materials.

One way of getting more power from a jet is to run it at even higher temperatures than at present, but this involves using special, scarce metals able to withstand intense heat. British designers believe a far more satisfactory answer is to use hollow turbine blades which can be cooled by air drawn from the compressor and channelled up inside them. They could be kept comparatively cool despite increased temperatures inside the engine, and could therefore be made of cheaper, less rare material. Alternatively, use of the finest possible metals would permit still higher temperatures and hence more power.

Bristol 40-Seat Helicopter

To meet B.E.A. requirements for a large passenger-carrying helicopter for use on British routes by about 1958, Bristols have started work on their new 40-seat Type 181. It is basically a scaled-up version of the twin-engined, twin-rotor Bristol 173, described in the "M.M." of April last, but will have stub wings, a retractable undercarriage, more powerful engines and generally improved performance.

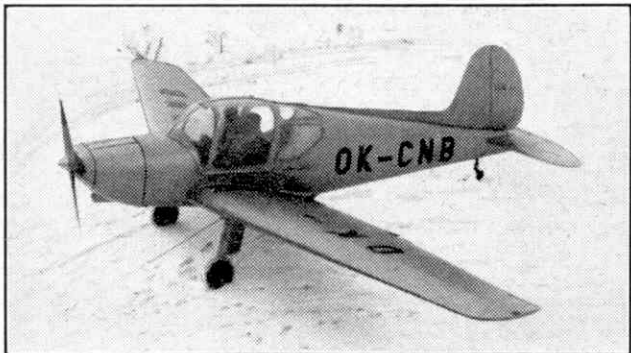

Czech Zlin 22 "Junak" 2-3 seat light aircraft.

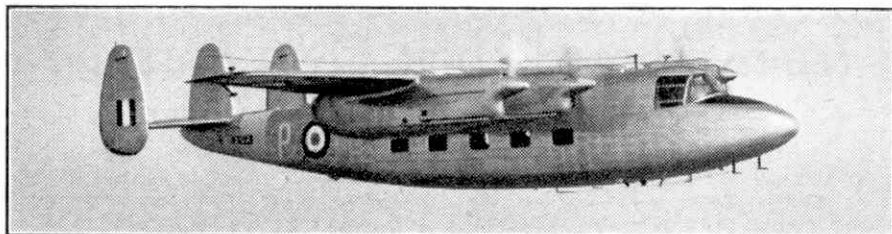

Handley Page "Marathon" with R.A.F. markings. Photograph by courtesy of Handley Page Ltd.

"Marathons" for the Royal Air Force

To speed training of the hundreds of navigators needed for its new bombers, transports and patrol aircraft, the Royal Air Force has ordered 30 Handley Page "Marathons," specially equipped with Rebecca and Gee radar, radio compasses, astro-domes and pear-drop windows to give the trainees an all-round view.

The "Marathon" should make a useful crew trainer as it has a roomy cabin, range of 1,400 miles at over 200 m.p.h., and is able to maintain height with full load on any two of its four "Gipsy Queen" engines. Its chief use will be for advanced training flights from the United Kingdom as far afield as Malta and Gibraltar, with a normal complement of one staff navigator, two student navigators, staff pilot and signaller.

New customers for the standard "Marathon" 18-22 seat air liner include Union of Burma Airways, and West African Airways who will operate four on their 6,500-mile network of tropical routes in Nigeria, the Gold Coast and French West Africa.

N.A.T.O. Flies to Paris

When the London Headquarters of the North Atlantic Treaty Organisation moved to Paris, Silver City Airways completed the biggest air removal job ever undertaken on this side of the Atlantic, by flying nearly 100 tons of the Organisation's furniture and equipment from Lympe to Corneilles Airfield, near the French capital. The cargo, which represented the contents of 200 rooms, was flown over the Channel aboard three Bristol "Freighters," each of which made six round trips.

The problem was to make the move without seriously disrupting the work of N.A.T.O. Surface transport would have taken too long. The "Freighters," each able to accommodate the loads of two pantechicians, did the job in four days.

Sky-High Colour Schemes

High-flying jet air liners, cruising "above the weather" for comfort and fuel economy, need specially

coloured cabins to counter strange sky lighting effects. At about 35,000 ft., for example, light entering the aircraft's windows is reflected up from the clouds below, and not from the sky above, which even in daytime is a deep blue-black because of the rarity of the air and absence of dust particles which reflect light at low altitudes and so make the atmosphere brighter.

Colour experts have already designed a special scheme for the "Comet's" cabin, with pale "ceilings" to reflect light from the clouds and careful toning with B.O.A.C.'s standard blue-grey colour scheme to reduce the heavy, clearly defined shadows produced in the clear air at great heights.

More Powerful "Cutlass" Fighter

Following successful Service trials of their original F7U-1 "Cutlass," both ashore and afloat, Chance Vought have produced a more powerful version of this unique sweptwing, tailless twin-jet fighter. The new aircraft, illustrated at the foot of this page, is designated F7U-3. It has been designed to outfly and out-fight any other naval fighter in the world. Details of its performance and equipment are secret, but its makers claim that it has exceptional manoeuvrability, better performance at height, greater range and heavier armament than the 650 m.p.h. F7U-1.

Concrete Wings

The French Breguet company have perfected a method of making aircraft wings of steel-reinforced cement, after more than three years of research. Extensive gliding tests have proved such wings highly-satisfactory for guided missiles. They can be turned out very quickly and cheaply and, provided the wing loading exceeds about 92 lb./sq. ft., weigh no more than wings built by conventional methods.

Although London Airport will be the main base for B.E.A.'s new fleet of "Ambassador" (*Elizabethan*) and "Viscount" (*Discovery*) air liners, it is unlikely that the Corporation will leave its present headquarters base at Northolt until 1956 at the earliest.

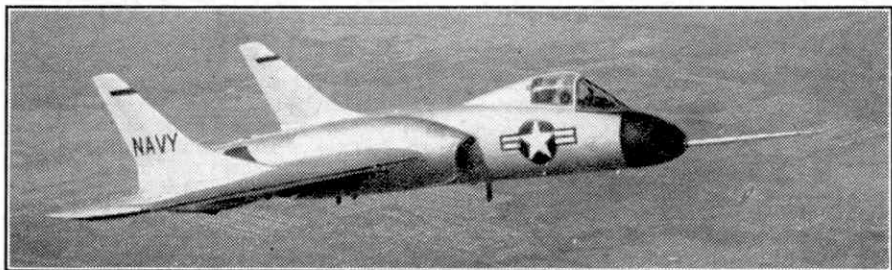

The F7U-3, a new and more powerful version of the F7U-1 "Cutlass" jet fighter. Photograph by courtesy of Chance Vought Aircraft, U.S.A.

Trains Record Their Own Passage

Safety Device Used on an Indian Railway

By H. C. Towers, M.I.E.E., M.Inst.T., M.I.R.S.E.

ON our railways it is necessary to know exactly where trains are on the tracks in order to be quite sure that there is no confusion that might lead to an accident. The electric track circuit was introduced for this purpose and has been in use for more than 50 years. With it the positions of the trains are shown on illuminated diagrams in signal cabins, which now are familiar to every reader of the "M.M." In addition the system

made to find a substitute for track circuits in places where these cannot be used. For instance, British engineers have experimented for many years with wheel counting apparatus. In this the wheels are made to operate treadles placed outside the rails and close to them. Unless the treadles register the exact number of wheels of a train the signals cannot be cleared.

The weak feature of apparatus of this kind was the treadle itself, since it had to take the blow of passing wheels. One type of treadle, illustrated at the foot of the opposite page, consisted of a set of six fingers, which were successively depressed by the flanges of the wheels. It was tested in a busy tunnel on the Cheshire Lines system near Liverpool. This is always full of steam, and the condition of the ballast makes track circuiting impossible. There, and elsewhere, it was found that mechanical operated treadles did not stand up to the passage of trains with speeds of 70 or 80 m.p.h.

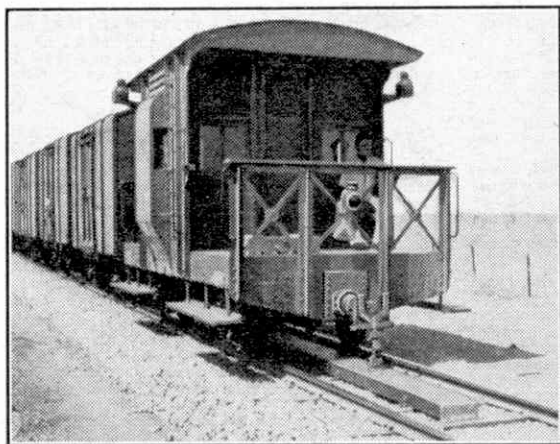

A goods train fitted with a device for recording its passage. Steel brushes attached to the brake van coupling connect two steel plates on a track ramp and complete an electric circuit to ring a bell at the nearest station.

ensures that points can be held in the right position until trains have passed over them. The signals also cannot be cleared until the section to which they apply is unoccupied.

There are situations where track circuits cannot be used, however. The reason for this is that there must be a certain electrical resistance between the rails, which form important parts of the track circuit. If the ballast and the sleepers are continually wet, as they are for instance in some tunnels, this electrical resistance is so small that the track circuits will not operate. This happens also with railways using concrete and steel trough sleepers, which is a standard practice in India.

Naturally, many experiments have been

Bombay, Baroda and Central India Railway, but now called the Western Railway. As already noted, track circuiting could not be applied here. Some of the sections of this railway have steep grades, and in the interests of safety special measures had to be taken to make sure that trains had arrived completely at the top of the grades. In the circumstances breakaways were possible, and owing to shortage of permanent way material, catch sidings to turn runaways off the track could not be installed.

The problem was solved by the introduction of a special form of apparatus that recorded the arrival at the top of the grade of the last vehicle. There are two parts to the device, one on the track

and the other on the train.

On the track there are two steel plates fixed between the rails a short distance beyond the end of the up grade. The plates are about three inches apart, and are mounted on a wooden structure so as to raise them an inch above rail level. They are about 25 feet long.

To the last vehicle of each train a pair of small steel brushes are fitted. These are attached to a clamp, which slides over the rear buffer casting—on our metre gauge system a central buffer only is used—and is locked in position by a pin. The steel brushes are bonded to each other to ensure perfect electrical continuity, and are designed to allow them a vertical movement by means of a rack and locking device to allow for different buffer heights.

The station at which the brushes are to be applied is provided with a gauge, consisting of a flat steel bar which is laid across the rails. In the centre are two blocks of steel half an inch lower than the height of the metal plates. The brushes are lowered until they rest on the blocks and are then locked in position. They are pivoted so that they can swing outward, but this movement is under the control of a powerful spring. The approach

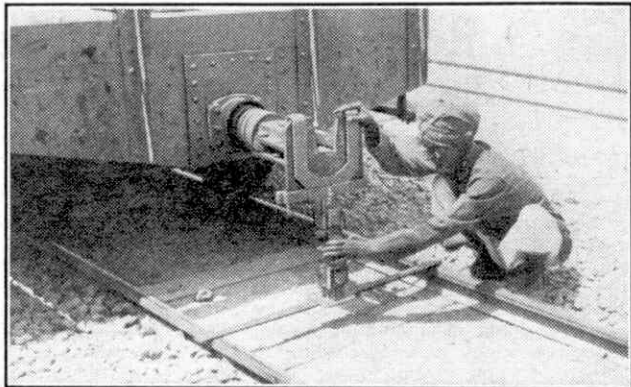

The height of the contact brush attached to the rear coupling of the last vehicle on the train is being gauged before the brush is locked in position.

to the plates is ramped so that as a train runs over them the brushes come into contact with them gradually, and the spring causes them to exert a powerful pressure on the surface of the plates so that any dirt or grease that might prevent electrical continuity is removed.

The joining of the two metal plates by the bonded brushes completes an electrical circuit, which causes a loud-ringing electric bell to sound at the station at the bottom of the grade. This tells the stationmaster that the whole train has passed beyond the detector. The bell continues to ring until he presses a plunger, and he can then accept a train from the rear section. The brush is sent back from the next station for use by succeeding trains.

The bell cannot be rung accidentally by permanent way men gauging the line, or deliberately by cattle boys or others joining the plates by wire. The reason for this is that matters are so arranged that there is no current if there is no train.

Brass or copper cannot be used for the plates or the brushes, as the ramps are situated in lonely places, and these metals are a great attraction to thieves. Even the steel plates used are riveted through the wooden mounting so that they cannot be prised up.

The idea of train contacts is not new and it was once used by the City and South London tube line. Its use in India came about simply because neither track circuits nor wheel counting devices could be used at the time.

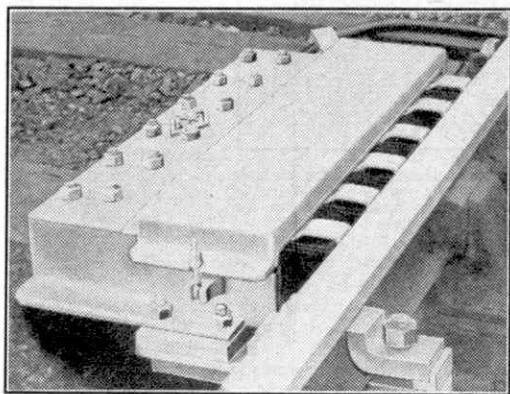

A wheel-counting device of the treadle type, with six fingers operated by the wheel flanges.

Robert Forrester Mushet

The Pioneer of Modern High Speed Steel

By E. N. Simons

ROBERT MUSHET was born in 1811 at Coleford in the Forest of Dean. He was the son of David Mushet, himself a metallurgist of some distinction who was the discoverer of the Blackband ironstone, which enriched Scotland. He also invented the process known as "fettling" in iron manufacture, which was carried out in a puddling furnace for making wrought iron. According to the inventor's son, one firm of iron manufacturers alone gained over £500,000 in the course of fourteen years by the use of this process. David Mushet also invented a method of producing steel by melting bar iron with charcoal.

In his early years at Coleford Robert Mushet helped his father in the experiments in metallurgy with which he was continuously occupied. In the course of these activities he became familiar with the value of manganese in the making of steel.

During the summer of 1848, Mr. Henry Burgess, Editor of "The Bankers' Circular," brought him a lump of metal of whitish, crystalline type, which he had found in Rhenish Prussia, where a mountain of it was said to exist. Burgess was under the impression that

this metal was pure iron, but Mushet saw at once that it was an iron ore largely composed of iron and manganese in alloy. With Burgess's help, he obtained an introduction to Mr. T. C. Banfield, a Queen's envoy, who had spent many years in Rhenish Prussia and was able to tell him that the alloy was a product of an ore called spathic iron ore. Nowadays

we should describe it as an alloy of iron and manganese containing from 12 to 20 per cent. of manganese. From its brightness it was termed "spiegeleisen," which literally means "looking-glass iron."

Mushet at once ordered twelve tons of the best spiegeleisen, which cost him about £14 a ton. He then began to combine this material experimentally with iron and steel, and discovered that with it he could reduce the cost of iron and steel production, and also could improve the quality of the steel produced.

His most important experiments, however, were concerned with the restoration of the quality of what was known as "burnt" iron, i.e. hot iron spoiled by long exposure to flames and heated currents of air. This iron was practically worthless, but Mushet discovered that its original quality was restored by alloying it with spiegeleisen. He now set to work to discover the principle underlying this fact, and concluded that the low quality of burnt iron was caused by excess of oxygen. By eliminating this oxygen, the spiegel allowed the iron to recover its normal structure. His next step was to endeavour to remove the oxygen in other ways, but in this he did not succeed.

Over the next few years Mushet familiarised himself with the use of spiegeleisen in steel alloying. Then, in 1856, Bessemer's famous paper on making steel by blowing air through it in his well known converter was read at a British Association meeting. Mushet was not

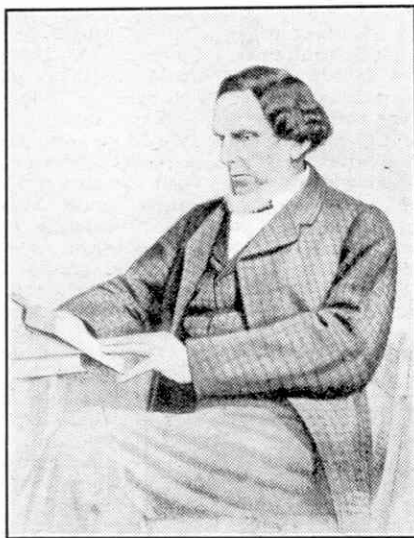

R. F. Mushet, a famous metallurgist and the inventor of self-hardening steel. He was the discoverer of the value of spiegeleisen in making steel by the Bessemer process.

present on that celebrated occasion, nor did he hear of the paper until two days after it had been read. Then it was mentioned to him by Thomas Brown of the Ebbw Vale Iron Co., who brought samples of the refined metal produced by Bessemer and made from Blānavon pig iron.

Bessemer's paper showed Mushet that the metal obtained was similar to burnt iron. He saw that the blast Bessemer used would not succeed in eliminating either sulphur or phosphorus from the metal. Mushet had already shown that these were dangerous and harmful impurities, and he asserted that Bessemer would not succeed unless he removed not only these, but also the imprisoned oxygen, from the steel. Knowing from his own experiments that metallic manganese would do what was required, he persuaded Brown to erect a small Bessemer hearth, which was unsuccessful. Brown's consequent consultation with him led Mushet to write the following passage:

"One of these bars, Mr. Brown brought to me, it resembled an old-fashioned puddle bar, from the worst red-short iron, only it was far more deeply cracked.

"Mr. Brown held it up in one hand, and said, 'See, this is all we can do; can you help us?' I replied, 'Yes, I can.' The metal of this bar was exceedingly soft and tough, almost as much so, as fine copper. I had part of it cut into small pieces, and of these, I placed 16 ozs. in a small clay crucible, and placed the crucible with a lid upon it, in a small assay furnace, capable of fusing wrought iron. Into another smaller crucible, I put 1 oz. of pure Siegen spiegel, and placed the crucible, in the flue of the melting furnace. When the contents of the crucibles were melted, I withdrew quickly both crucibles from the furnace and poured the melted spiegel into the melted Bessemer metal, and then emptied the mixture into a small ingot mould. The ingot was smooth and piped, and had all the appearance of good cast steel. I heated this ingot, to a fair cast steel heat. Mrs. Mushet held the ingot in a pair of tongs, and with a sledge hammer, I drew one half of it into a flat bar. This bar I heated and twisted in a vice, at a white heat, a red heat, and a low red heat. It remained perfectly sound and clear in the edges, and not a

trace of red-shortness remained. I next doubled the bar, welded it, drew it into a chisel, which I hardened, tempered and tested severely, on hard cast iron. It stood well, and was in fact, cast steel worth 42/- per cwt. I saw then that the Bessemer process was perfected, and that, with fair play, untold wealth would

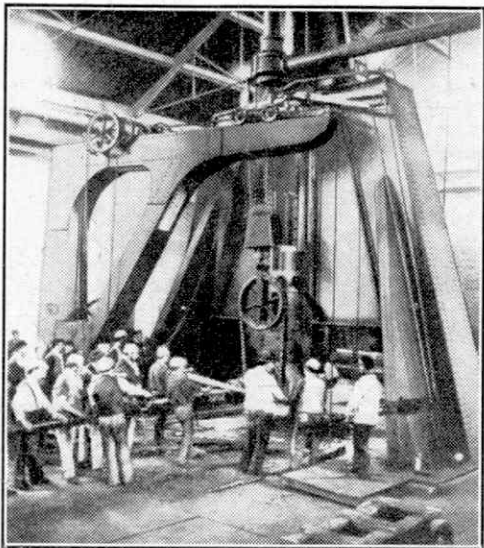

Forging under a steam hammer at the works of John Brown Ltd., Sheffield, in 1865.

reward Mr. Bessemer and myself."

On 16th September 1856 Mushet took out three patents for improving iron by blowing air through it when in a molten condition. Two other patents by him were entered on the 22nd of the same month. He based his claim to the invention on his patent of the 22nd, in which he specifies: "The addition of a triple metallic compound of iron, carbon and manganese to cast iron, which has been purified and has been decarbonised by an action of air whilst in a molten or fluid state."

He took out other patents, but by an unfortunate accident, all his patent rights at home and abroad were extinguished at a blow. Mushet states that this arose because one trustee of his 1856 patent, Mr. Blackwell, was in overwhelming pecuniary difficulties, and Blackwell and Thomas Brown, the other trustee, let the matter rest until the third year's stamp duty of £50 fell due, when they neither paid it nor notified Mushet that they had not done so.

Mushet admitted that Bessemer, whose process was a failure until he introduced the addition of spiegeleisen, would probably have made the same discovery as himself in time, but he claimed to be the first to use this remarkable alloy. He never received wealth and honours on the scale of those conferred upon Bessemer, but in 1876, with Bessemer's own approval, he received the Bessemer Medal of the Iron and Steel Institute. Bessemer paid Mushet £300 a year for some years before his death, but refused to pay him any royalties. He challenged Mushet to bring an action if he considered his patent

the autumn of 1868. A piece of it was given to me at the time by Mr. Mushet, with whom I continued to be intimately associated until his death in January, 1891.

"The new Steel was evolved after several months of experimenting in Steel Alloying, conducted, by the way, with quite another object in view. Mr. Mushet wished to take out a patent, but I opposed that method of telling everybody 'how it was done,' and reminded him of the patents he had already taken out, and the absence of benefit therefrom to himself. I said, 'Let us try a secret for once,' and a secret it has remained for 33 years, and is likely to remain."

Mushet was self-contained and self-reliant. He said of himself: "I was never inside any Steel Works but my own, and never even saw the outside of one except that of the Avon Side Steel Works at Bristol."

Singularly, Sheffield, which benefited largely by Mushet's inventions, was never visited by him. For a metallurgist, he was remarkably ready with the pen. From 1848 onwards, he was a correspondent of "The Mining Journal" under the signature of

"Sideros," and during the years 1857-1858 he wrote a series of letters to that paper on the Bessemer process, while carrying on a correspondence on the same subject under his own name.

His book entitled "The Bessemer Mushet Process of Manufacture of Cheap Steel" was published in 1883. The illustration on this page shows Mushet's own handwriting on a presentation copy given by him to Robert Woodward, one of his associates in the old days at Coleford and later to become Chairman of the large steel works of Edgar Allen and Co. Ltd., Sheffield.

Mushet died on 1st January 1891 at Cheltenham, aged 79, after many years of ill-health. A full-dress life story is in course of preparation, its publication being assured; and metallurgists the world over are eagerly awaiting it.

Note: Since the article was written the above book has been published under the title "The Mushets," by the late F. E. Osborn. The publishers are Thomas Nelson and Sons Ltd.

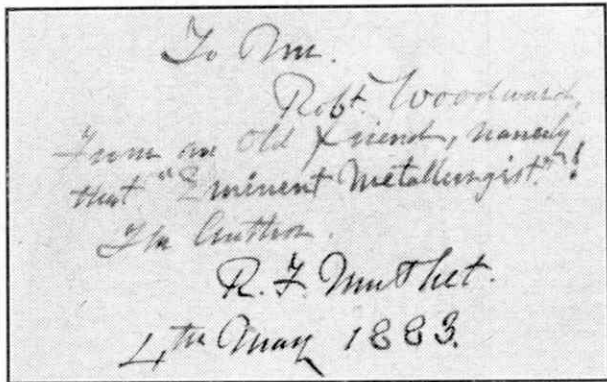

A signed inscription by Mushet in a presentation copy of his book on the Bessemer process.

had been infringed, but Mushet declined to do this.

The controversy between these two metallurgical giants, human and understandable though it was, must have taken some of the sweetness out of their lives. Mushet never lost the feeling that he had been wronged, while Bessemer suffered inevitably from the attacks, whether justified or not, made upon him by Mushet.

Between 1859 and 1861 Mushet took out twenty patents for the manufacture of alloys of iron, tungsten and chromium. His experiments with tungsten alloys led to the invention, in or near the year 1870, of the celebrated Mushet self-hardening steel, the forerunner of the modern and indispensable high speed steels. In an article dated November 1901, Robert Woodward, later chairman of a large Sheffield steel firm, wrote:

"The first ingot of 'Self-Hardening' Steel that could be successfully forged was made at Coleford, in the Forest of Dean, England, by the late R. F. Mushet, in

Photography

At the Seaside

By E. E. Steele

THE hot spells of July make most of us long for the delights of the sea, if only on a day trip, and cameras are very much in evidence among seaside holiday makers—sometimes too much so, as when one sees a camera lying on a heap of discarded clothing in the hot sun, plentifully sprinkled with sand! Great care should be taken of the camera at the seaside, as salt-spray and sand are extremely injurious to both lens and mechanism. Keep your camera in its case when not in use, and shield it when using it in the wind, for sand particles seem to lodge everywhere.

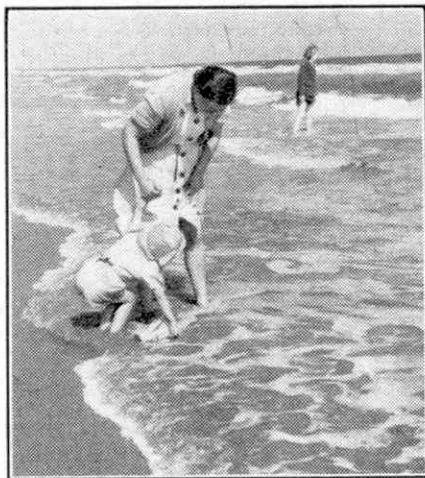

Seaside fun.

There is a marked difference in the various seaside resorts. Some have just sea and sand to offer, while others can provide an interesting fishing fleet, or the charm of a rocky coast. Wherever there are boats attractive pictures are there for the taking. This can be much more interesting than just taking snapshots of bathers, which often turn out disappointing when seen against expanses of calm sea, especially if at all over-exposed.

Indeed, over-exposure can be a problem at the seaside. Sea and sand reflect an enormous amount of light, and therefore considerably less exposure is required than that normally given when taking pictures back at home. A faster shutter speed may be used, or the lens stopped down one or two stops. If this is not possible, a slower film may be used,

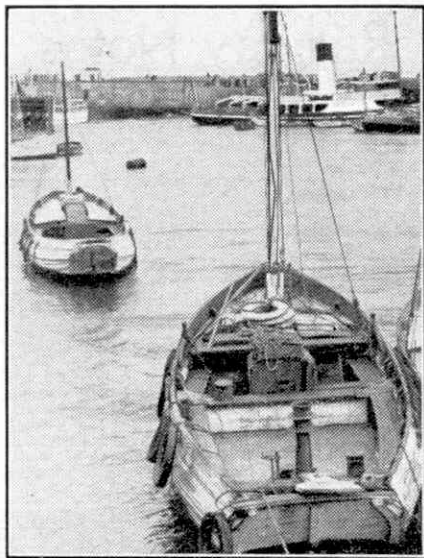

Boats at Bridlington. The illustrations to this article are from photographs by the author.

for fast panchromatic films can give very flat results when over-exposed.

The strong reflections of light from sand, sea and sky, make it very desirable to use a lens hood to shade the lens. This reflected light, if allowed to shine directly into the lens, can cause flatness and fogging, and often streaks of differing density spoil an otherwise good result. When loading or unloading roll film at the seaside, seek a shady spot or get someone to hold a coat, for such strong light has a habit of penetrating the edges of the backing paper, especially if the coils are allowed to become at all loose.

When photographing the sea it is helpful to have a boat or breakwater in the foreground to add stability to the picture. The best pictures are made when the sea is in a boisterous mood.

These are but a few subjects among the host awaiting at the seaside, and an "eye for a picture" should be cultivated.

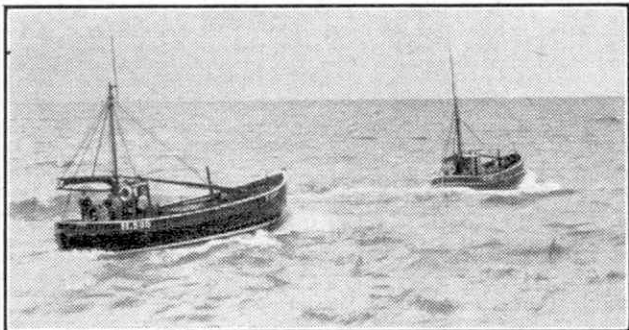

Putting out to sea.

Railway Notes

By R. A. H. Weight

Summer Train Services

British Railways Summer timetables came into operation on 30th June and the early weeks of July will see the introduction of the full holiday season services, including a number of accelerations and innovations. The down "Atlantic Coast Express" is timed to cover the 83½ miles from Waterloo to Salisbury, from Mondays to Fridays, in 83 min. This provides the first mile-a-minute start-to-stop timing on the S.R. and what will probably prove to be the quickest booking for any train in or out of London this year, or since the recent war. The express schedules between Waterloo and Portsmouth also have been quickened, the Saturday frequency being increased this season from three to four electric fast trains in each direction per hour—the most intensive regular main line service on record—catering largely for Isle of Wight passengers.

Accelerated trains include the "Capitals Limited" running non-stop between London and Edinburgh, the "Cornish Riviera Express" with a 4½ hr. timing between Paddington and Plymouth, the "Mid-day Scot," the S.R. Plymouth-Brighton service, the W.R. through Wolverhampton-Birmingham-Penzance expresses, via Bristol, which receive the name "The Cornishman" except on Saturdays; Bradford-Leeds-Liverpool, and others of which full details are not yet to hand. More Saturday and Sunday long-distance trains will be run, with an extensive selection of cross-country through services connecting large towns with coastal or other holiday resorts, such as Newcastle-Gloucester-Cardiff; Newquay-York; Birmingham-Weymouth; Liverpool-Bournemouth; Preston-South Wales; the Midlands and the Kent and Sussex coasts.

Reserved seat facilities are available on 5,530 services per week. Overall passenger train mileage must still be restricted in order to save coal for the Winter, which means that many trains have to convey heavier loads and make more stops than was the case in 1939. There are also speed restrictions due to track being repaired or awaiting renewal, but many running improvements have been effected and, on the whole, this Summer's outlook is bright.

Concentration of Parcels Traffic at Marylebone

Many of us have been familiar with the piles of parcels often lying on the platforms at Euston, King's Cross or St. Pancras stations, and also with the long strings of loaded barrows towed by station tractors that take up a lot of room on the passenger concourses. To provide more space for passengers and their luggage as well as to speed up the transit of the heavy parcels and similar traffic between the south and north of England, the service has been reorganised by dint of converting Marylebone goods station, one of the biggest in London, into a parcels sorting depot. Additional parcels trains are being run to and from Marylebone goods station connecting with all parts of the Midlands and North.

The road fleets used to convey parcels between the

London termini (there is a very large interchange with the Southern system) hitherto mainly consisting of motor vans, are being replaced by mechanical horse units with detachable trailers. These trailers can be unloaded or loaded while the "horse" is engaged on other loads.

Scottish Locomotive News

"Clan" class light 4-6-2s Nos. 72006-9 have been allocated to 68A, Carlisle (Kingmoor) shed, it being understood that their names are respectively "Clan Mackenzie," "Clan Mackintosh," "Clan Macleod" and "Clan Stewart." Their duties include the haulage of the night boat and mail trains between Carlisle and Stranraer, as well as day services on the Stranraer-Glasgow route, involving steep gradients in both cases. These complete the first order for 10 engines.

New "B1" 4-6-0s Nos. 61397-8 are stationed at 64A, St. Margaret, Edinburgh. No. 61505, Great Eastern 4-6-0 of class "B12," has been withdrawn. Reports have been received of ex-L.N.E.R. "Pacifies" and "V2s" working over the former L.M.S. main line between Aberdeen and Perth, together with other interchange locomotive running.

Southern Travel Observations

Within two months up to the time of writing I have travelled over 1,600 miles by Southern main line, semi-fast and local, steam and electric trains, largely through the lovely country of the Home



"Sunday Excursion" is the title of this Summer photograph by W. S. Garth. It shows a typical platform scene on the arrival of a train at a seaside town.

counties but including journeys in and out of London. I rode on all three Sections during the evening peak hours, when the traffic handled is enormous, yet every train used or observed was punctual or within a minute or so of booked time then as well as during the day. Some fast trains were ahead of time.

Vigorous running by "Schools" 4-4-0 No. 30910 "Merchant Taylors" with the lightly loaded 11.10 a.m. Hastings-Charing Cross made us 3-4 min. early on arrival at Tunbridge Wells, Sevenoaks and Waterloo (Eastern) with a clear road. The smaller "L" class engine built in 1914, No. 31767, kept time nicely on the same express with easy handling; the minimum speeds at the top of the two worst climbs being 10-12 m.p.h. lower than those achieved by "Merchant Taylors." At Tonbridge I saw "Merchant Navy" No. 35029 "Ellerman Lines" with a 10-coach train, and "Schools" No. 30918 "Hurstpierpoint" with seven on, both pass 2.3 min. before working times on the down and up. Folkestone non-stop early evening expresses. I heard, too, of a very fast run on the up "Golden Arrow" hauled by standard 4-6-2



A complete train of S.E.C.R. origin photographed last year by D. Ives, Hastings. No. 31496, a Wainwright "D" 4-4-0, is shown leaving West St. Leonards with a 3-coach train for Tonbridge.

"William Shakespeare," and noted a mile-a-minute start-to-stop run by a "Battle of Britain" with 10 corridors on the 26½ miles Tonbridge-Ashford.

On Easter Monday "King Arthur's" were much in evidence on specials from the Kent coast to London; and a "U" 2-6-0 took a 10-coach relief booked without a stop from Ashford to London Bridge by the difficult Maidstone route. I travelled from Hastings to Ashford that day behind L.M.R. type 2-6-4T No. 42098, which gained time, and I returned behind a 45-year-old "H" 0-4-4T which was rather loaded to excess with six bogies, but it made a stout effort. The first "Pacific"-hailed train seen at Hastings was one of the specials to and from Wembley on April 5th, in connection with the schoolboys' international football match, travelling by way of Lewes and Clapham Junction, the engine being No. 34046 "Braunton." The sister "West Country" No. 34047 "Callington" headed a similar special from Eastbourne, both being stationed at Brighton.

For 10 weeks recently, owing to engineering works in Hastings Tunnel, single line working was in force through St. Leonards, Warrior Square, with electrically controlled crossovers in Hastings and Bo-Peep Tunnels.

On a through Ramsgate to Reading slow train I travelled from Redhill to Guildford behind an S15 4-6-0, No. 30836 (75b), the formation being an S.E. & C.R. "trio" or three-coach set such as figures in our St. Leonards illustration this month. Another such set was used on the return journey when the locomotives were U 2-6-0, No. 31613 (70E) as far as Redhill where, after reversal, one of now rare E class 4-4-0s, No. 31315, took over to work to Tonbridge.

At Woking in just over 15 min. in the evening I saw three Pacifics call on West of England or Bournemouth trains, as well as a Bournemouth "Lord Nelson" running through. At Virginia Water or Staines "King Arthur" and H15 4-6-0s, also 0-6-0s of widely differing type and age from "Q1" to the veteran Adams "0395" class, were noted on through or local goods. The last S11 Drummond 4-4-0, No. 30400, was in steam at Guildford, where the last surviving 60-yr.-old Southampton Docks 0-4-0 saddle tank, "Ironside" was on view.

Early in April, No. 35028 "Clan Line" (73A) was working temporarily from Exmouth Junction (72A), being observed on the 6.0 express from Waterloo; 11 days later I saw her pass Ashford (Kent) at high speed on the Dover boat express following the "Golden Arrow."

When travelling recently in electric London-Sussex coast trains formed of express stock, I have in both directions covered the 27½ miles Haywards Heath-E. Croydon in less than 28½ min., also Gatwick Airport-Haywards Heath, 11 miles in 11½ min., all start to stop.

London Midland Tidings

New engines completed include class "2" 2-6-2Ts Nos. 41322-3 allocated to SB, Warrington; No. 41324 to 5A, Crewe North; Nos. 41300-8 for service on the S.R.; class "2" 2-6-0, built Darlington, No. 46498 to 20A, Leeds; 46499-500, 18A, Toton. Class "4" B.R. standard 4-6-0s constructed at Swindon are Nos. 75018-9 at 27C, Southport. Diesel electric 0-6-0 shunter No. 12099, is at 16A, Nottingham.

Llandudno Junction, Bangor, Holyhead and Rhyl sheds are re-numbered respectively 6G, 6H, 6J, 6K, Bletchley and Leighton Buzzard are now 1E, Northampton is 2E. Ten 4-4-0 Compounds are included in the 6G stock. There were once 50 L.N.W.R. 2-4-0 tanks, the design dating back to 1876; 40 of them were later converted to the 2-4-2 wheel arrangement. We illustrate the last one, just withdrawn from the severely graded Cromford-High Peak line in Derbyshire, which in L.M.S. days was No. 6428, then 26428, becoming 58092 in 1951. It worked between the top of Sheep Pasture incline and the lower end of Middleton incline.

A reader writes that "Royal Scot" or "Jubilee" 4-6-0s have regularly run over the Furness line between Carnforth and Workington for some time. Class "G" 4-6-2 "Clan Campbell" hauled a special train from Euston to Rugby on 8th April. Shortly before that the Fell Diesel Mechanical locomotive, No. 10100, was working between Derby and St. Pancras. The four "J39" E.R. 0-6-0s have left Cricklewood shed where they had been stationed for a considerable period.

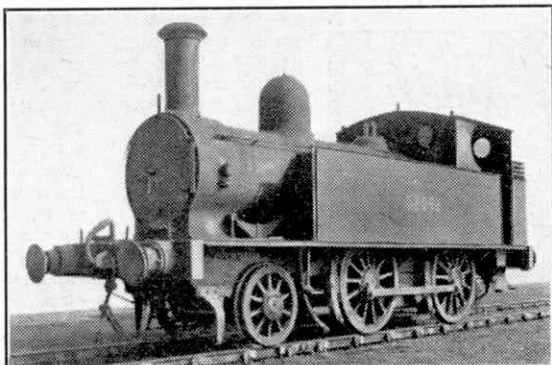

L.M.R. No. 58092, the last of the Webb 2-4-0 tanks, now withdrawn. Except for certain details it is little changed in appearance from former L.N.W.R. days. British Railways Official Photograph.

Among the Model-Builders

By "Spanner"

A Cure for Slipping Belts

A useful Meccano gadget that will be found helpful in belt-driven models was sent to me recently by R. James, Cardiff. It is a device for overcoming the trouble that is sometimes caused by belts slipping through becoming slack after a period of working, and although I have not been able to try it out practically, I have no doubt that it would prove satisfactory. The mechanism is shown in Fig. 1 on this page. It includes a reduction gear unit, and depends for its action on the tendency of the pinion of the gear unit to climb round the teeth of the Gear, carrying with it the Strips 2 and thus tightening the driving belt. The tendency of the Pinion to climb round the Gear increases as the load increases, so that under a very

heavy load considerable tension is applied to the driving belt. The drive from the power unit is taken by a belt to a 1" Pulley on a Rod 1. The bearings for this Rod are provided by two 2½" Strips 2, connected together by a ¾" Bolt 3, and the Rod carries between the Strips a ¾" Pinion 4. The Strips 2

Pinion tends to climb round the teeth of the Gear, carrying with it the Strips 2 and thus tightening the driving belt. The tendency of the Pinion to climb round the Gear increases as the load increases, so that under a very



Ian Pilkington, Liverpool 16, a successful competitor in a recent model-building competition.

heavy load considerable tension is applied to the driving belt.

Roller Bearing

Cranes and similar machines such as excavators are among the most popular subjects for Meccano models, probably because they can be made to work so much like the real machines. Models of this type usually have a large and heavy swivelling superstructure,

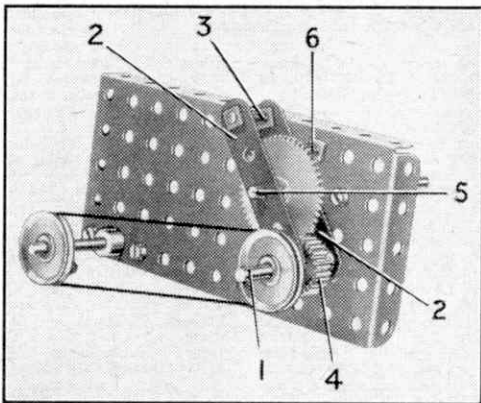

Fig. 1. A belt tensing device that will be found useful in connection with belt-driven models.

are free to pivot about the final drive shaft 5, which is fitted with a 1¼" Gear that meshes with Pinion 4. The movement of the Strips 2 is limited by a ¾" Bolt 6.

When the mechanism is in motion the drive from Rod 1 is transmitted to the output shaft through the Pinion 4 and the 1¼" Gear, but at the same time the

and if the model is to work smoothly and be really pleasant to operate, it is necessary to see that this is supported on a really satisfactory bearing. The complete Ball Thrust Bearing, part No. 168, is an ideal bearing unit for small and medium sized cranes, but for very large models an extremely strong built-up bearing is required, such as that shown in Fig. 2. This uses two Flanged Rings for the bearing surfaces. One of the Flanged Rings is bolted to the tower or stationary part of the model, and the other is fixed to the lower part of the cab or revolving superstructure. The rollers are ¾" Flanged Wheels, and they are carried on a special framework or "spider," which is free to pivot on the centre shaft of the bearing.

The spider is made by bolting eight 3"



J. Sloan, Ecclefechan, a prize-winner in the "October" model-building Competition.

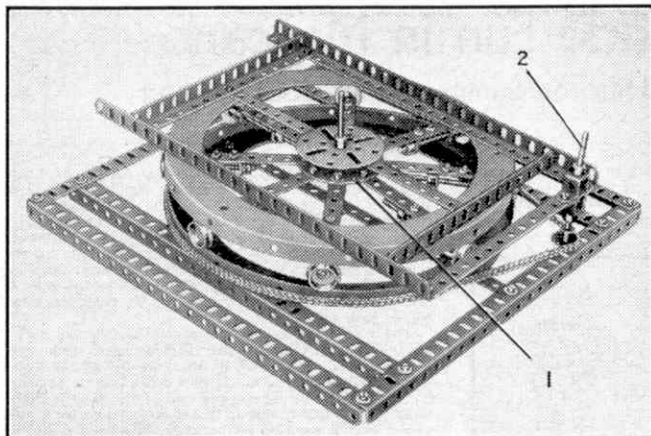

Fig. 2. A strong built-up roller bearing that is ideal for supporting the heavy superstructures of large cranes and excavators.

Strips radially to a Face Plate 1, and each Strip is extended by a $1\frac{1}{2} \times \frac{1}{2}$ " Double Angle Strip that overhangs the 3" Strip by one hole. The Flanged Wheels are fixed on $2\frac{1}{2}$ " Rods mounted in the Double Angle Strips. Each Rod is held in place by a Collar, and a second Collar is positioned between the Flanged Wheel and the Double Angle Strip.

The centre shaft is a Rod passed through the Face Plate 1 and through Strips or Angle Girders bolted across the upper and lower Flanged Rings. The Rod can be left free to turn in the bearing, so that in a travelling crane it can be used to transmit the drive from a Motor mounted in the cab, to the wheels.

The superstructure can be slewed by driving a Rod 2 mounted outside the Flanged Rings. A $\frac{3}{4}$ " Sprocket on the lower end of this Rod should be connected by Sprocket Chain to the Flanged Ring fixed to the base.

Meccano Helps the Film Industry

Meccano seems far removed from the Southlands of the Minstrels and "Ol' Man River," but I am sure readers will be interested to know that a large and realistic working Meccano model of a Mississippi Showboat

stern-wheel steamer features in the publicity campaign for the Metro-Goldwyn-Meyer film "Showboat" that is now touring this country. The model, which is shown at the foot of this page, has been displayed in the foyers of many large cinemas throughout the country. It is about 3 ft. 6 in. in length, and the stern-wheel is driven through a crankshaft from an Electric Motor. It is modelled as closely as possible on the "Cotton Blossom,"

the stern-wheeler

that figures so prominently in the film, and it has attracted considerable attention wherever it has been displayed.

How to Use Eccentrics and Cranks

Young model-builders are sometimes uncertain regarding the uses of eccentrics and cranks. The great advantage of an eccentric is that it permits a reciprocating movement to be obtained from a rotating shaft without breaking the line of the latter. Unlike a crank, however, it can only transform rotary to reciprocating movement, and cannot be used to produce rotary motion unless triplicated. The most common use for an eccentric is in the operation of valve mechanisms for reciprocating steam engines.

Fig. 3. The Meccano model of the "Cotton Blossom" that is referred to on this page.

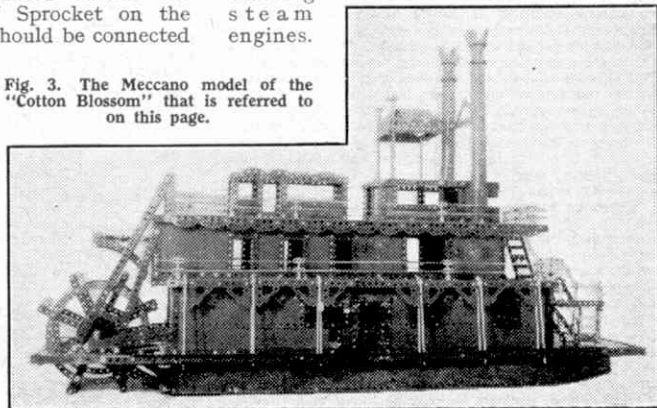

Seaside Fun in Meccano

Suggestions for Summertime Model-Building

AT this time of the year many model-builders will be looking forward to spending a week or two at the seaside, and we should like to remind them of the many possibilities for models of the lighter type that are provided by the lively scenes and activities of almost any seaside resort.

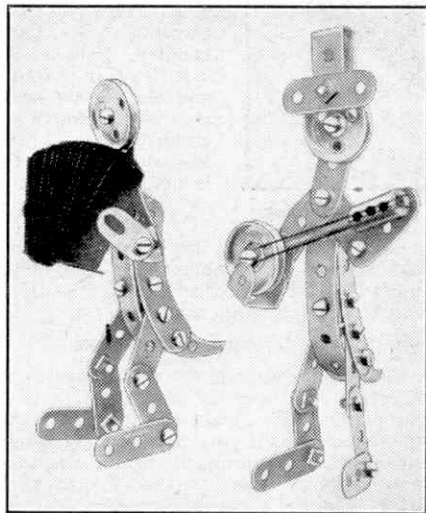

Fig. 1. These Meccano minstrels are sure to attract large audiences, although their instruments are silent.

Piers and fairgrounds have already provided us with many splendid Meccano models, but there are countless possibilities beyond them. Pierrots, minstrels and bathers are all obvious subjects for fascinating and effective model-building of a more simple type. Something exciting or funny always seems to be happening at the seaside, and a wide range of incidents also can be turned to good account. Meccano figures of course must be prominent in models of this kind, and it is fascinating to see how cunning arrangements of the parts representing the legs and arms of such figures can transform a simple and uninteresting subject into one that is full of life and vigour. Models of this kind have the great advantage that they offer splendid opportunities to owners of small Outfits and others who enjoy devising models of the simplicity type.

Evenings at the seaside may be enlivened by a visit to the pier or hall in which a concert party is performing. Here are to be found many ideas for humorous models. Fig. 1 is a good example. It shows a concertina player and a banjoist. Both are shown dressed in tail coats, and the latter wears a top hat!

The construction of these figures is simple. Each consists of two large-radius Curved Strips, connected together by one Double Bracket, the centre portion of which forms a support for a $2\frac{1}{4}$ " Strip bent to the shape shown. Legs and arms are represented by $1\frac{1}{2}$ " Strips, pivoted to provide knees and elbows,

and the long boots typical of most minstrels are formed from $1\frac{1}{2}$ " Strips. In both cases $1\frac{1}{2}$ " Strips and $1"$ loose Pulleys are used for neck and head, and the top hat carried by one of the figures is built up from a short Strip and a Single Bent Strip.

The concertina is a pre-war Hornby Corridor Connection, the ends of which have been filled in with small pieces of black cardboard cut to the required shape. This use of the Hornby Corridor Connection is ingenious and effective. If the part is not available, the concertina can be built up from folded paper.

The banjo carried by the second figure can easily be built up from a $1"$ fast Pulley fitted with a $2"$ Screwed Rod. The Rod is fitted in one of the holes in the boss of the Pulley, and is locked in position by the set screw. The upper end of the Rod is fitted with a Threaded Coupling locked in position by a nut, and a bolt is used to connect the Threaded Coupling with the $1\frac{1}{2}$ " Strip forming one arm of the figure. Banjo strings can be suitably represented by Meccano Cord.

Swimming, diving, and sunbathing are naturally the main attractions of a seaside holiday, and suggestions for a variety of new models can be obtained by watching those who take part in these pastimes. One of the most recent additions to water sport in this country is surf board riding, and a simple, but effective model of a surf rider is illustrated in Fig. 2.

The construction of the surf board is very simple. A rectangle is first formed from two $5\frac{1}{4}$ " and two $1\frac{1}{2}$ " Strips. These support a $5\frac{1}{4}$ " x $1\frac{1}{4}$ " Flexible Plate, and the front end of the board is curved by making use of two Pawls, without Boss. The figure is built up in a somewhat similar manner to those shown in Fig. 1, and $2\frac{1}{4}$ " large radius Curved Strips are used to form the body. Two lengths of Meccano Cord complete the model.

It will be realised that the disposition of the Strips forming the figure is of major importance in a model of this kind, for the whole atmosphere must be one of thrill and speed, and a streamline effect is therefore necessary.

If desired a model motor boat can be built to tow the figure.

Fig. 2. This Meccano surf rider undoubtedly is enjoying himself immensely.

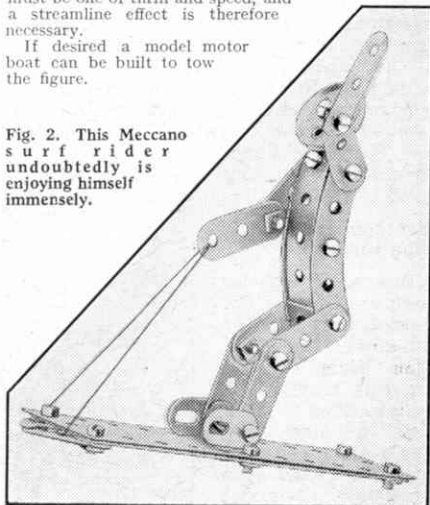

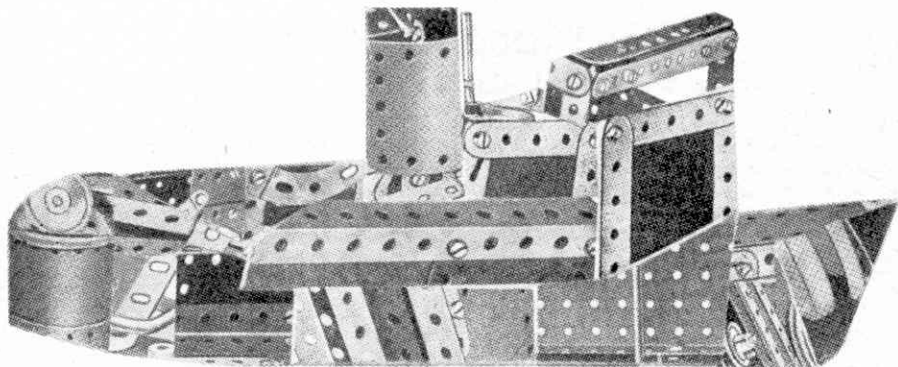

This picture of a Tug forms the subject of the novel competition announced on this page.

A Test for Sharp Eyes

Another Special Summer Competition

DURING the Summer months we realise that even the most ardent model-builders prefer to spend as long as possible out-of-doors, and the time that can be given to serious model-building is therefore rather limited. But there are always some rainy days, unfortunately, and in any case practically every model-builder likes to keep in touch with his hobby throughout the Summer months.

These special competitions are exactly what is wanted at this season, as entries can be prepared in comparatively short time. We are sure they will be welcome too in countries south of the Equator, where it is now Winter, so the contests are made open ones in which every reader can join.

This month's competition, the second in our 1952 series, does not require any actual model-building or even the use of Meccano parts, so that entries can be completed at home or on holiday. All that is wanted indeed is a Meccano Instructions Book for Outfit No. 6.

The illustration on this page looks like a picture of a tug that obviously is made with Meccano. But close inspection will reveal that it is actually built up from a number of cuttings taken from illustrations of Meccano models of various kinds. All these illustrations appear in the

current Instructions Book for Outfit No. 6. But it should be made clear that they are not necessarily pictures of No. 6 Outfit models; some of them are from the sections of the Book giving examples of models built with the smaller Outfits. Further, the cuttings are not necessarily shown in the same attitude that they occupy in the complete illustrations—some indeed may be upside down—and two or more cuttings from the same model may be included.

We invite readers to try to identify each of the cuttings and then to write on a postcard the number and name of the model from which each is taken. If a competitor thinks that two or more cuttings from any particular model have been used this must be indicated in the list.

The following prizes will be awarded for the best solutions received: First, Cheque for £3/3/-; Second, Cheque for £2/2/-; Third, Cheque for £1/1/-. There will

be also 10 prizes of 10/- and 10 of 5/-.

The competition is open to readers living in any part of the world, and the closing date is 30th September.

Entries must be addressed, "Meccano Tug Competition, Meccano Magazine, Binns Road, Liverpool 13." The competitor's age, name and address must be written on the entry.

MODEL-BUILDERS!

Next month's "M.M." will give you news of a wonderful opportunity of showing your skill in your favourite hobby.

LOOK OUT FOR IT!

New Meccano Models

A Motor Cycle and Sidecar and a Useful Balance

THE neat motor cycle and sidecar is shown in Figs. 1 and 2 is driven by a *Magic* Clockwork Motor built into the position normally occupied by the engine of an actual machine.

The frame of the cycle is made by bolting two $2\frac{1}{2}$ " Strips 1 on each side to the side-plates of the Motor. The Strips seen in Fig. 1 are fixed direct to the side-plate, but only temporarily, as at a later stage in the construction the bolts will have to be removed in order to fit the sidecar. The Strips shown in Fig. 2 are connected to $\frac{1}{2}$ " Bolts, each of which is attached to the Motor side-plate by two nuts. The Strips 1 are connected at their upper ends by $3\frac{1}{2}$ " Strips 2, which form part of the petrol tank.

Each side of the tank is completed by a further $3\frac{1}{2}$ " Strip 3, and this is linked by a Fishplate at its forward end to Strip 2. The front of the tank is filled in by four $1" \times 1"$ Angle Brackets, two of which are bolted to the Strips 2, while the remaining two are fixed to Strips 3. A Coupling 4 is connected to the latter pair of Angle Brackets by two bolts passed through the Brackets and screwed into tapped holes of the Coupling.

The rear wheel is supported on each side by a $4\frac{1}{2}$ " Strip 5 and a $2\frac{1}{2}$ " Strip 6. These Strips are attached to the main frame as shown in Fig. 2, and a $1\frac{1}{2}$ " Rod is mounted in the end hole of Strip 6 and the centre hole of Strip 5. The Rod is

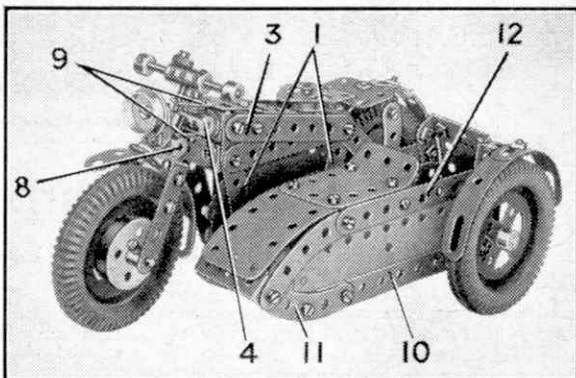

Fig. 1. A neat motor cycle and sidecar, which has a *Magic* Motor for its power unit.

fitted with a $1\frac{1}{2}$ " Pulley 7, a 2" Pulley and Motor Tyre, and a 1" loose Pulley. The $1\frac{1}{2}$ " Pulley is connected to the *Magic* Motor pulley by a Driving Band.

The driver's saddle is a Flat Trunnion that is attached by a $\frac{3}{8}$ " Bolt, which carries six Washers, to a 1" Triangular Plate. The Triangular Plate is bolted to two $1" \times \frac{1}{2}"$ Angle Brackets fixed between the rear ends of Strips 2. The rear mudguard consists of two Formed Slotted Strips bolted to a Double Bracket attached to the end holes of Strips 5. It is braced by a 2" Strip on each side. These Strips are passed over the rear axle, and are connected at their upper ends by a $1\frac{1}{2}" \times \frac{1}{2}"$ Double Angle Strip that is bolted to the mudguard.

The front fork is made by joining together two $1" \times 1"$ Angle Brackets by bolts passed through the Brackets into the tapped holes of a Coupling 8. The front wheel is free to turn on a $1\frac{1}{2}"$ Rod passed through the end holes of 2"

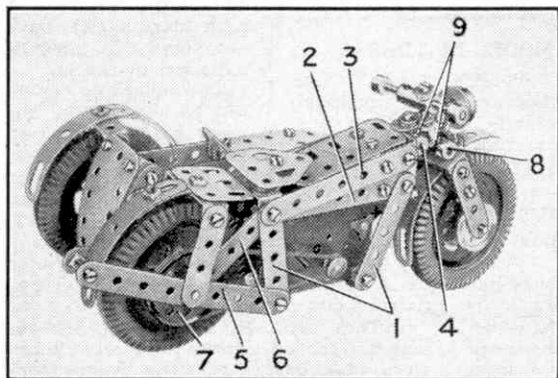

Fig. 2. Another view of the motor cycle and sidecar.

Strips bolted to the Angle Brackets. A 1" loose Pulley is placed on one side of the wheel, and a 1 1/8" Flanged Wheel is fixed on the Rod at the other side.

A 1 1/4" Rod is fixed in the centre hole of Coupling 8, and this Rod is free to turn in two Fishplates 9, placed one above and one below the Coupling 4 and fixed in place by bolts screwed into the Coupling. The front mudguard consists of a Formed Slotted Strip and a 1 1/2" Strip which are bolted to a 1" Triangular Plate held by the same bolts that fix the Angle Brackets to the Coupling 8. The headlamp is a 3/4" Flanged Angle Girder. Two Corner Gussets 1 and 2 are bolted as shown to the Flat Girder and these support a Face Plate. The dial pointer consists of a 1" Rod held in a Rod and Strip Connector 3. The Rod and Strip Connector is fixed to the shank 4 of a Rod Socket, which is mounted on the end of a 1 1/2" Rod journaled in a hole in the Face Plate and in a Double Arm Crank bolted to it.

Each side of the sidecar is made from a 5 1/2" x 1 1/2" Flexible Plate braced along its lower edge by a 5 1/2" Strip 10, and extended by a 2 1/2" Curved Strip 11. The upper edge of the side is made from a 2 1/2" Curved Strip and a 4 1/2" Strip 12, and the rear edge is a further 2 1/2" Curved Strip. The sides are connected together by two 1 1/2" x 1/2" Double Angle Strips at the rear, and by one 1 1/2" x 1/2" Double Angle Strip at the front. The back is filled in by a 2 1/2" x 1 1/2" Flexible Plate bolted to one of the Double Angle Strips, and the nose is completed by two 2 1/2" x 1 1/2" Flexible Plates shaped as shown and attached to the sides by Angle Brackets.

The sidecar axle is a 1" Rod held in a Coupling that is fixed vertically to the side by a 1/2" Bolt passed through

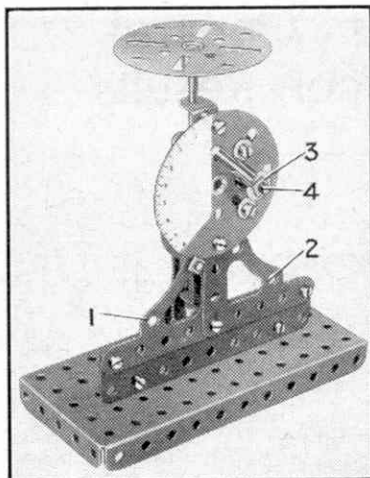

Fig. 3. A useful weighing balance for light articles.

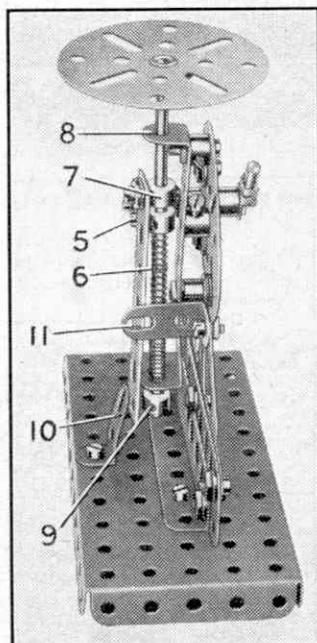

Fig. 4. A side view of the balance showing the constructional details of the mechanism.

the next-to-end hole of Strip 10.

The two bolts holding Strips 1 to the Motor are now removed, and two 1 1/8" Bolts are passed through the lower edge of one side of the sidecar and are fixed in position by nuts. The Bolts are then passed through Strips 1 and the Motor sideplate, and each is held in place by two nuts.

Our next model is a useful balance suitable for weighing light articles. Construction should be begun by bolting a 3 1/2" Angle Girder to a 5 1/2" x 2 1/2" Flanged Plate, and then attaching a 4 1/2" Flat Girder to the

Two Corner Gussets 1 and 2 are bolted as shown to the Flat Girder and these support a Face Plate. The dial pointer consists of a 1" Rod held in a Rod and Strip Connector 3. The Rod and Strip Connector is fixed to the shank 4 of a Rod Socket, which is mounted on the end of a 1 1/2" Rod journaled in a hole in the Face Plate and in a Double Arm Crank bolted to it.

The 1 1/4" Rod carries also a Washer and a 1/2" Pinion 5. The Pinion engages the teeth of a 3 1/2" Rack Strip 6, which is bolted to a Collar 7, fixed to a 5" Rod. It will be found necessary to space the Rack Strip from the Collar by means of a Washer. The 5" Rod is free to move in the arms of a 3 1/2" x 1/2" Double Angle Strip 8, which is bolted to the Face Plate by means of 1/2" Bolts, Collars on the Bolts being used to space the Double Angle

(Continued on page 334)

Christmas "General" Competition Results

By "Spanner"

THE list of prize-winners in the Christmas General Model-Building Competition is as follows:

First Prize, Cheque for £5/5/-: A. M. Hardie, Aberdeen. Second Prize, Cheque for £4/4/-: N. Gottlob, Hjortekaer, pr Klampenborg, Denmark. Third Prize, Cheque for £2/2/-: B. W. Rowe, Buckfastleigh.

Consolation Prizes of 10/-: H. W. Henry, Strood; J. M. Quinodoz, Sion, Switzerland; J. Kritzinger, Potchefstroom, Transvaal, S. Africa; K. Jones, Berala, N.S.W., Australia; R. Marr, Cathcart, Cape Province, S. Africa; B. Fraser, Palmerston North, New Zealand; P. Farrell, Buenos Aires, Argentina; I. F. Macrae, Harrow Weald; E. L. Wilkes, Peterborough; A. W. Jeffries, North Harrow; J. E. Bridger, Hastings; F. Millman, Newton Abbot; R. G. Holding, Colwyn Bay; P. H. Mynott, Great Shelford; M. L. Murdoch, Redruth; G. S. Henderson, Edinburgh 7; S. Reid, Aberdeen; J. Matthews, Filongley; H. H. Taylor,

for a most ingenious instrument called a radio wave synthesizer, which is designed to show in graphic form the effects of modulation on radio waves. This is one of the most outstanding



K. Hooker, Port Elizabeth, S. Africa, one of the prize-winners in the Overseas Section of the September Competition.



Fig. 1. A model of a Commer Lorry built by J. Matthews, Filongley, Coventry.

Huddersfield; P. Lewis, Flamborough.

Consolation Prizes of 5/-: B. C. Shert, Hersham; M. Phillips, Paignton; K. Hill, Girton, Notts.; M. Holmes, Barnet; W. M. Alexander, Middlesbrough; D. C. Mills, Caernarvon; M. Stone, Nottingham; R. M. Minshull, Macclesfield; P. Knowles, Chesterfield; K. J. K. Gray, Dunstable; A. B. King, Steckport; R. S. Fotheringham, Forfar; A. Coppola, Birkirkara, Malta; J. Houry, Marne, France; H. Roskaff, Ler, Norway; J. P. Chartier, Paris XV; J. Wegelin, Alberta, Canada; J. Tertzakian, Heliopolis, Egypt; G. B. Thompson, Napier, New Zealand; E. M. Evans, Swansea; K. Jones, Birmingham; T. Roberts, Putney; I. Davies, Liverpool 4; V. Thompson, Newcastle; N. Rawlings, Wolverhampton.

The Christmas General Model-Building Competition was one of the most successful ever announced in the "M.M.," producing an exceptionally fine crop of entries. The First Prize was awarded to A. M. Hardie, Aberdeen,

models of its kind that I have seen. I am sorry I cannot illustrate it. Owing to the extremely complicated nature of the mechanism the photographs are not suitable for reproduction.

The Second Prize was won by N. Gottlob, Hjortekaer, Denmark, who built a very fine model of one of the huge ore unloaders working at ports on the Great Lakes in North America. This entry was prepared in book form, with meticulous care, but unfortunately the

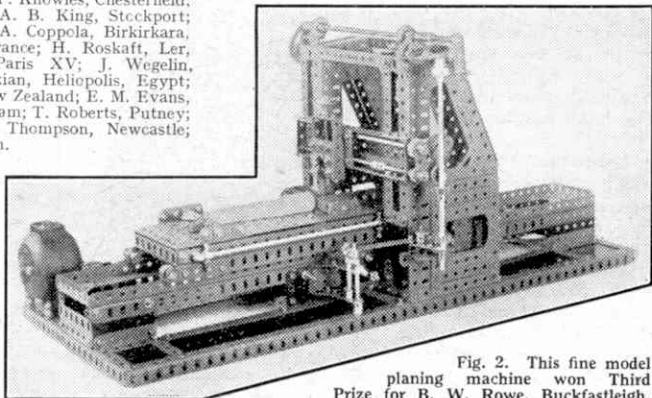

Fig. 2. This fine model planing machine won Third Prize for B. W. Rowe, Buckfastleigh.



Fig. 3. S. Reid, Aberdeen, photographed with his fine prize-winning model trolley-bus. Photograph by courtesy of the Aberdeen Bon Accord.

photographs available are not really suitable for illustrating the model satisfactorily.

B. W. Rowe, Buckfastleigh, S. Devon, won Third Prize with the finely detailed and well-proportioned planing machine shown in Fig. 2. This model is powered by an E020 Electric Motor, and the mechanism is very well designed and set out.

The neat motor lorry shown in Fig. 1 was built by J. Matthews, Filongley, whose name also is included in the list of prize-winners. The model is based on a Commer Lorry, and readers will note the careful use of Strips and Plates in making the body, which is very sturdy.

The fine trolley-bus shown in Fig. 3 was built by S. Reid, Aberdeen, who is shown demonstrating the model.

P. Mynott's model of a combine harvester earned for him one of the Consolation Awards. The harvester is shown in Fig. 4 ready for action, with a number of filled sacks in the delivery chute at the side.

More Competition Results

JANUARY "OUTFITS" CONTEST (Home Sections)

Section A

First Prize, Cheque for £3/3/-: S. D. James, Ruislip. Second Prize, Cheque for £2/2/-: D. S. Lewis, Ferryside, Carmar. Third Prize, Cheque for £1/1/-: J. M. Davies, Whitchurch.

Five Prizes, each of 10/6: D. Neale, Edinburgh 9; A. H. Spinks, Liverpool 16; Y. Bowen, Abernant; S. C. Harvey, Sidcup; E. Sargeant, Market Drayton.

Five Prizes, each of 5/-: M. Rowley, Huddersfield; H. W. Wood, London N.1; A. Murphy, London N.3; A. Ibbott, Barham; D. Oldacre, Sawbridgeworth.

Section B

First Prize, Cheque for £3/3/-: C. E. Wrayford, Bovey Tracey. Second Prize, Cheque for £2/2/-: K. S. Willett, Canterbury. Third Prize: Cheque for £1/1/-: K. W. Taylor, Gillingham.

Five Prizes, each of 10/6: N. Hancock, Smethwick 41; R. G. Sayer, Margate; P. G. Auden, Coates; R. Martin, Ewhurst; R. Hughes, Walsall.

Five Prizes, each of 5/-: M. G. Membrey, Redditch; I. Hartwell, Hindhead; L. Weaver, Horsham; T. F. Carr, Hornchurch; J. D. B. Petit, St. Peter Port.

"SEPTEMBER GENERAL" CONTEST (OVERSEAS SECTION)

First Prize, Cheque for £3/3/-: A. W. Dickie, Auckland, C.3, New Zealand. Second Prize, Cheque for £2/2/-: G. J. Retief, Elsburg, Transvaal, S.A. Third Prize, Cheque for £1/1/-: K. Jones, Berala, N.S.W., Australia.

Ten Prizes, each of 10/6: A. Schiffmann, Zeglingen ob Fecknau, Switzerland; S. J. Reid, Quebec, Canada; R. Corp, Peterborough, Ontario, Canada; P. Fernando, Colombo 13, Ceylon; T. Searson, Salisbury, S. Rhodesia; H. Smith, Port Elizabeth, South Africa; K. Hocker, Port Elizabeth, S. Africa; M. Wilkins, Montevideo, Uruguay; J. Lagesse, Curepipe, Mauritius; B. Jones, Nimbin, New South Wales, Australia.

Ten Prizes, each of 5/-: R. Green, Melburne, Victoria, Australia; B. Fish, Saskatchewan, Canada; A. Mey, Geraldton, West Australia; C. Fraser, St. Georges, Grenada, B.W.I.; R. Lubeseder, Alberta, Canada; I. Inglis, Havelock North, New Zealand; R. Houy, Witfeld, Transvaal; R. Ball, Cape Town, S. Africa; C. Cooper, Melbourne, Australia; S. Thompson, Vancouver, B.C., Canada.

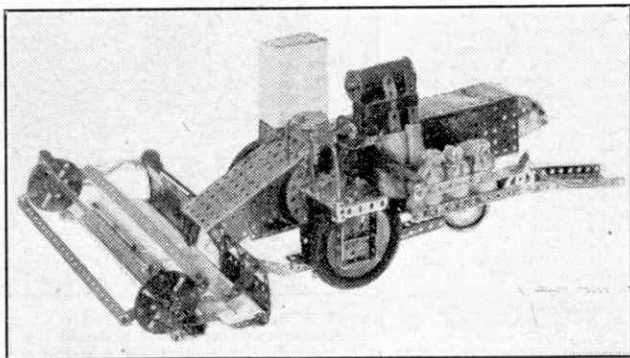

Fig. 4. A combine harvester built by Peter Mynott, Great Shelford.



Club and Branch News



WITH THE SECRETARY

MORE REPORTS, PLEASE!

I have just been reading a long and very interesting report of a recent Exhibition, received from the Secretary of the Club concerned. The details that he enthusiastically relates have enabled me to visualise the scene so well that I almost feel that I had been present at the display. There are other Clubs and Branches, of course, that send me long, detailed reports of their activities, but in some instances these reach me only about once a quarter and are made to cover most of a single Session's programme. These reports certainly tell me what the Clubs and Branches have been doing, but by the time they reach this page they are very old, and some of their value is lost because they have to be summarised on account of shortage of space.

The ideal report is a shorter one sent monthly, so that I can follow the work of the Club or Branch as the Session progresses. Such regular reports form important links between a Club or Branch and myself, and are most helpful to other Clubs and Branches.

The Secretary is recognised as the official "reporter" of a Club or Branch, but I like to hear from time to time from Leaders and Chairmen, who can give me a general idea of progress, with stories of outstanding events, or of good work by individual members.

CLUB NOTES

CRYPT GRAMMAR SCHOOL (GLOUCESTER) M.C.—The subject of a recent Model-building Competition was "Cars," and there were some excellent entries. Preparations are in hand for the Annual Exhibition. Club roll: 25. Secretary: Mr. P. T. G. Hobbs, 31, Estcourt Road, Gloucester.

BURY GRAMMAR SCHOOL M.C.—The second Winter session ended with a short meeting at which the prizes were distributed to the winners of the Model-building Competitions. A visit to the aircraft works of A. V. Roe and Co. Ltd. was greatly enjoyed. Model-building activities are in abeyance during the Summer months, but occasional model railway meetings may be held. Club roll: 36. Secretary: Mr. J. A. Strafford, 13, Maple Grove, Prestwich, nr. Manchester.

HORNSEA M.C.—The President and Leader gave a very interesting Lecture on the working of a clock, and illustrated it with a film strip and actual clocks borrowed for the occasion. A Geography Talk by him included a film of native life in East Africa. The annual Voting Session, at which members choose the items for the following year's programme, gave rise to friendly argument but ended very satisfactorily! Club roll: 15. Secretary: Mr. D. Stevenson, 29, Southgate Gardens, Hornsea, E. Yorkshire.

MILE END (PORTSMOUTH)

M.C.—The Exhibition was a great success, and the visitors totalled 290. As usual, the Hornby-Dublo Layout was the main attraction, but the display of Meccano models also came in for high praise. The Models shown included a Gantry Crane, Destroyer, Gallean, two Electric Engines—one of them working, and a large Locomotive and Tender. An interesting feature of the Exhibition was the showing of road safety instructional films, and of a film "Night Mail" illustrating the collection of mail bags from express trains at speed, by Police Sgt. Kent and P. C. Hale. A discussion about this film took place at a subsequent Club meeting. Club roll: 44. Secretary: Mr. A. J. Nicholson, 213, Sultan Road, Blandford, Portsmouth.

AUSTRALIA

MAYLANDS M.C.—Model-building continues to be the main activity of members, and many ambitious models are in hand. A new system of allocating points has been adopted in the popular "Rumpus Room" feature. There have been two very enjoyable outings, to a riverside beach and an ocean beach respectively. The Club film strip projector has been put to good use by the Secretary and another member, who each presented a film show to children in their district. Refreshments were provided, and the proceeds, totalling 35/1, were paid into the Club funds. Club roll: 40. Secretary: Mr. R. Fletcher, 10, Harrow Street, Maylands, Perth.

BRANCH NEWS

WATERLOO (DUBLIN)—Successful timetable working has been carried out at the regular Monday meetings, with normal train operations supplemented by special services as required. Members have attended meetings of the Irish Railway Record Society, and took part in a trip on the C.I.E. Cashel Branch. Secretary: Mr. S. J. Carse, 38, Oakley Road, Ranelagh, Dublin.



Mr. G. L. Beach, Leader, and members of the Royal Grammar School M.C., Newcastle-upon-Tyne, with models entered in a Club contest. This Club was affiliated with the Meccano Guild in November 1948. Model-building figures largely in the programme. Hornby Train operations, Film Shows and Visits to places of interest are among the other varied activities of the Club.

HORNBY RAILWAY COMPANY

By the Secretary

Outdoor Layouts Again

LAST month I told you about a Hornby-Dublo railway mounted on a baseboard that could be taken bodily out-of-doors for running in fine weather. This month I have another outdoor picture, showing Malcolm Garratt in the garden with his Hornby Trains—and no doubt many of you will follow the example of these enthusiasts when sunny days allow you to do so.

It is necessary for me to remind you that Hornby railway material is not intended for *permanent* use out of doors, where rain would lead to rusting, but there is no reason why a railway should not be laid down outside when the weather is suitable. This is easy where it is fixed on a baseboard that is in sections, and even if the whole track has to be fitted up each time it is wanted a move into the garden is worth while for the fun and variety it will bring.

A good level path or walk can make quite a good base for the track. A lawn on which the grass is cut really short also will do nicely, and this has the advantage that the "countryside" for the railway is automatically provided. The question of levels is important and the track should be laid with special care, especially at the rail joints. Otherwise there might be mysterious derailments when operations are in full swing!

Another point to remember—when the railway is being taken up wipe over all components that have been in contact with the ground. This will make sure that no rusting will start.

At one or two places the lie of the ground may mean that the railway track requires supporting here and there in order to keep it at the same level throughout. Meccano Parts can readily be used to make up

simple supports of the kind required. There may be scope for more serious bridge work on a railway out-of-doors, but this will depend to a great extent on the contour of the ground where the line is laid.

In the photograph Malcolm Garratt, who lives at Horsforth, nr. Leeds, is obviously having a good time with his Hornby Trains outside. His railway began when he was given an MI Goods Train Set and since then it has been enlarged by the addition of points and

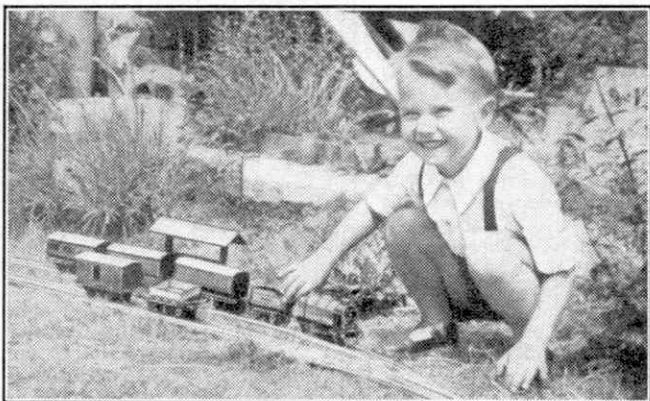

When Malcolm Garratt of Horsforth, nr. Leeds, spent a happy day in the garden with his Hornby Trains, his brother G. A. Garratt photographed him with his layout and won a prize in a Magazine Photographic Competition with the result.

further rails, while the introduction of more Hornby rolling stock has allowed a train of really satisfactory length to be assembled. Malcolm particularly likes using his Milk Van and the Flat Truck, as these are ideal for loading purposes. The Milk Van has its own special load of cans supplied, but with the Flat Truck he can really let himself go in looking for novel freights.

There are two stations on the layout, both made at home, so that the trains have somewhere to start and stop, as any respectable train should have. There is one trouble still, however. This is that trains have outgrown the capacity of the MI engine, but Malcolm is now looking out for more locomotive power.

Loop Lines on Hornby Railways

EVERY Hornby Train owner likes to have a siding, if only to use the Points and Buffer Stops that are almost always included in a Hornby railway owners' equipment! A more compelling reason is that every real railway has sidings. They are indeed necessary for the storage of rolling stock, and from a single siding to a group of them, forming a yard, is an obvious step, providing wonderful opportunities for shunting and other railwaylike proceedings.

With a single siding terminated by Buffer Stops, trains can be run directly into it, but then the engine has to back its train out in order to resume the journey. Alternatively, if the train is first backed in, then the engine will be in position to lead the train out again when required.

Which of these practices is followed depends on which end of the siding the points are placed. There is no difficulty if there are points connecting to the main line at *both* ends of the siding, which then becomes a loop line, a very useful addition to any layout.

As the railway grows, and the number of trains run on it is increased, it is better to have one or more loop lines, which then provide for continuous running in

that a Straight Half Rail is required between the Points and the curved rails at each end of the loop. This sets the loop line farther away from the main track than the usual "6 ft-way," but running loops in actual practice are not necessarily close to the main line. So there is nothing

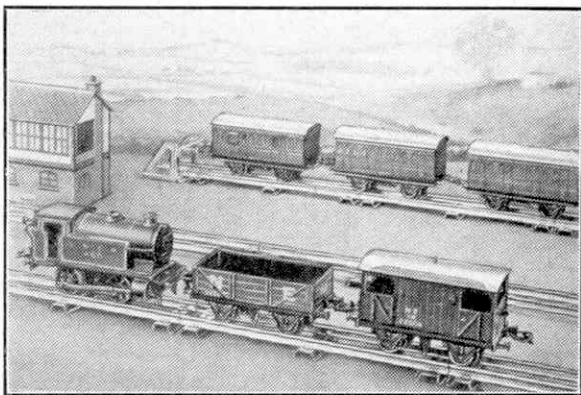

A Hornby 101 Tank Locomotive on its way to pick up further vehicles "down the line." The track immediately behind the train is a loop of the kind described in the article.

unrealistic in this layout, which has the advantage that it gives easier running than would be the case if the curves were joined immediately to the points. This is of considerable benefit when operations are in progress, especially when loop lines are being used for through running rather

than storage purposes. Another good feature is that the Hornby No. 3 Station can be accommodated between the two tracks, if required.

The diagram shows the arrangement using 2 ft. radius curves and points, and it will be noted that a Straight Quarter Rail is included in the straight part of the loop. This is necessary in order to ensure that the rails join up satisfactorily.

On 1 ft. radius loops the Curved Rail at each end is attached directly to the curved branch of the Points. Then the number of Straight Rails in the loop is two less than the number in the main line.

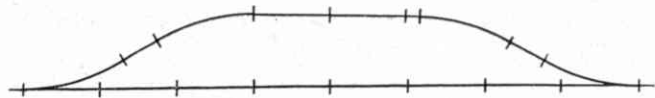

There are various ways of making up loop lines with Hornby Rails and here is an arrangement that will be found useful.

either direction. In working a train service one train can be held in a loop while another traverses the main line, and so on. A loop is a good thing to have even if only one train is in use, for it gives a useful alternative route to the main line.

Some Hornby railway owners appear to be a little doubtful as to the way in which to form loop lines. A possible and simple arrangement is shown in the diagram on this page. It will be seen

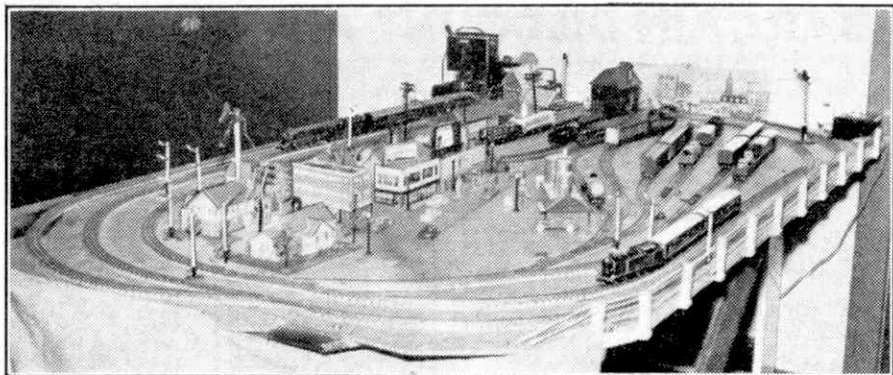

The Pacific Great Western Railroad

By A. J. Tomlin

A Hornby-Dublo enthusiast from North Vancouver, British Columbia, tells readers of the "M.M." how his railway started, and how it has grown since he took up the hobby. "Real railroading" has always been his aim, and he is still making "improvements" of the kind that give so much fun to owners of Hornby-Dublo Railways.

AT first glance "M.M." readers may be excused for thinking the Hornby-Dublo layout shown in the picture and diagram on this page is far too complicated for a single enthusiast to run. But if they look it over carefully they will see that it is so laid out that all or any part of it can be worked alone. They may also find difficulty in believing that it all started with just the regular Hornby-Dublo Goods Train Set. Yet that is so. The Pacific Great Western Railroad, as I call it, has two goods trains, one "Sir Nigel Gresley" passenger train and one "Duchess of Atholl" passenger train. There are somewhere around 15 Points and several Uncoupling Rails installed, and the running that I am able to carry out is an excellent representation of real railroading.

The system has taken me three years to build up, three years of the most interesting model railroading I've spent in many years of this hobby. After getting the first Goods Train Set, I sought eagerly for more trackage until the outer circuit was completed. Next came a loop that eventually allowed two passenger trains to operate, each in turn, on the one circuit. Gradually further track was acquired and another goods train, and later I was able to build the inner circuit and so run two trains at once.

Nothing would do then but to have a crossover from one line to the other. Then sidings had to be installed. The first was the passenger car siding behind the station, the next a spur to the coaling station, and so on.

As opportunity offered both isolation and uncoupling sections were installed in this section. The next job was one of purely experimental nature—building a turntable. This really warrants an article to itself. Eventually, I did succeed in making one that worked, but later I took it out and substituted for it the "Y" connection between the two sets of sidings. Lack of length in the layout makes it available only to turn around either an engine, or a tank engine and one car.

Now with this "Y" completed my small layout has more facilities for realistic

railroading than many several times as large. After about three years of constant changing around and seeking to improve its operation there seems but one thing lacking; that is, of course, space for extension. So as it now stands it will have to remain—except for the minor "improvements" that all good model railroaders are everlastingly making! Model railroading is fun provided always that one is willing to provide the little items that make all the difference between "running round and around" and seeking to reproduce real railroad practice. A goods yard, properly laid out, with the necessary Uncoupling Rails and Isolating Rails installed, will provide any amount of work to keep one operator busy, while another runs the passenger trains.

Remember that the layout I have begun with simply a train set. The continual small accumulation of equipment enables one gradually to build up a reasonable system. In this way there is always something to look forward to. I have never known a model railroader who admitted that his layout was finished!

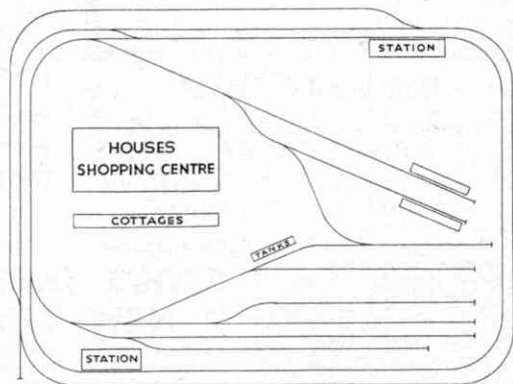

This diagram of the Pacific Great Western Railroad of A. J. Tomlin, North Vancouver, with the picture of the line at the head of the page, will help readers to follow the owner's story of the growth of his fine layout.

BARGAIN DISCOUNT APPROVALS!

Large, fine selections of picked stamps—yours for the asking. (We pay postage one way). Singles, new issues, etc., plus a grand book of sets. Generous discount allowed. "Wants" lists of single stamps welcomed. These are the REAL collector's approvals. Why not try them TO-DAY? There's no obligation to buy. We offer "Adult service for Junior Collectors."

THE BIRKDALE STAMP CO.
104, Liverpool Rd., Southport, Lancs.



Postal Business Only

Build your collection  way.

THE "NEW MERCURY" APPROVAL SERVICE

offers you

- Fine stamps—attractively displayed and reasonably priced
- Beautiful and interesting issues
- Single stamps and sets

IN FACT—the stamps you want at prices you can pay.



We invite you to send for a "NEW MERCURY" Booklet on 10 days approval. See for yourself—there is no obligation to buy.

PHILIP J. DYKE 35, BUCKLEIGH AVENUE
LONDON S.W.20

NEWFOUNDLAND PACKET



FREE!

This very fine Mint pictorial Air Mail stamp (much sought after by ALL Collectors), can be yours **ABSOLUTELY FREE**, together with other fine stamps from this British Dominion off the East Coast of Canada.

This valuable packet of stamps will be sent to you by return of post **ABSOLUTELY FREE**. Just enclose 3d. postage and request one of our famous approval selections. Good discount given. Only one packet to each applicant, so write immediately.

L. E. THOMPSON (M.M.)

2, WESTERN GARDENS, LONDON W.5

FREE — 2/- KENYA K.G. VI

The above High Value stamp will be given free to all genuine applicants for our famous ONE PENNY APPROVAL BOOKLETS of BRIT. COLONIALS. These Booklets abound with JUBILEES, PEACE, CORONATIONS, SILVER WEDDINGS and U.P.U. as well as the latest K.G. VI stamps. Many Bargains as usual. N.B.—Enclose 2½d. stamp for Postage. S. FENLEY LTD., 250, Charminster Rd., Bournemouth

FREE — EXPLORERS & INVENTORS

A fascinating lot of stamps showing such famous people as Christopher Columbus, Leonardo da Vinci, Vasco da Gama, Stanley, Captain Cook and others. All these absolutely free. Just send 3½d. for postage and price list and ask to see our famous "3d. UPWARDS" approvals.

Write to-day to:

CAPT. M. CAMPBELL & CO. (Dept. MM)
58, High Street, Watford, Herts.

★ WORLD-WIDE PACKETS ★

Sample selection 1/- + + 2½d. stamp for lists. J. THOMPSON, 42, BOURNEMOUTH ROAD, BLACKPOOL

3 Send 2½d. for my latest approvals **FREE**
D. J. Palmer (M16), Highwood Hill Camp, Mill Hill, N.W.7

+ **FREE! NEW ISSUE HUNGARY TRIANGULAR** +
Send postage for my 50% DISCOUNT APPROVALS.
M. Theobald (MM), 6, Dell Corner, West Drayton, Middx.



Fine Gifts, and "quality" approvals monthly. (Gifts inc. full-size Tweezers, etc.) (Stamp suppliers wanted abroad). — **WRIGHT'S STAMP SHOP** — (M33) — CANTERBURY — Kent. — Est. 54 years.

SCOUT JAMBOREE & 2 NEW SEYCHELLES FREE

As illustrated, but larger, very attractive and Free to collectors asking to see our famous "quality" (Discount) approvals. Send 3d. (abroad 6d.) to cover our postage and lists. If you wish you may join "THE CODE STAMP CLUB," Sub. 1/-. You receive Badge, Membership Card listing Weddings and latest commemoratives.

64 PAGE STAMP ALBUM FREE

Here's a FREE Stamp ALBUM for you. This magnificent offer is for one month only, so send IMMEDIATELY. It is the ideal album for beginners or for holding duplicates. The cover is most attractively designed in TWO-COLOURS, there are 64 PAGES containing 120 full-sized illustrations with spaces for new issues. It will hold over 1,200 stamps, INDEXED and contains much useful information. Remember, supplies are strictly limited, so send TO-DAY for this absolutely FREE GIFT. Enclose 6d. for packing and postage and request our famous Approvals together with illustrated price list of albums, packets and sets.

LISBURN & TOWNSEND LTD. (MM), West Kirby, Wirral

SOMETHING NEW — FREE!

To all applicants for my fine Colonial Approvals enclosing 3d. for postage, I will send absolutely free a 24-page printed Want List Book. Just the thing for listing your Stamp wants. S. POWELL, 28, Mount Park Rd., Ealing, London W.5

STAMP CATALOGUE FREE

Listing stamps of King George VI. Over 450 illustrations. Normally priced 3/6, **ABSOLUTELY FREE** if you ask to see approvals and send 5d. postage and packing. ROSTON (U), 106, St. Dunstan's Road, London W.6

FREE GREAT BRITAIN 5/-

Send 3d. post, request approvals containing U.P.U.s., Weddings and latest commemoratives. GODDARD, 29, ARCADE, BOSCOMBE, HANTS.

Stamp Collectors' Corner

By F. E. Metcalfe

THE BRITISH VIRGIN ISLANDS

THERE was a time when the announcement of a new set of stamps for the British Virgin Islands would have made a big stir among Commonwealth collectors. The rather dull set that has now been superseded, which has been on issue since 1938, has damped their enthusiasm for the issues of the colony, but the new pictorial set that appeared on 15th April last should do much to bring back the erstwhile popularity. It is a beauty. It will be welcome all over the Commonwealth and also in the United States, which has always evinced a particular liking for Virgin Islands stamps, probably because there are also U.S. islands bearing the same name.

The Virgin Islands form an archipelago in the West Indies, to the east of Porto Rico. Two countries now own them, Great Britain and the United States of America. The American Islands only contain 132 square miles in all, but even that pocket handkerchief space is more than twice the total area of the British islands. These number 30 and their area only amounts to 58 square miles, with a population of under six thousand.

Tortola is the largest island—the 12c. stamp shows a map of this—and the capital, Road Town, believe it or not, barely musters a population of five hundred, but what it lacks in size it makes up for in interest. As a matter of fact, all the islands are redolent with romance. Echoes and relics of Drake and Nelson abound. As one writer put it, the latter figure is more real to Virginians than many notables who are living today. Cotton, sugar and postage stamps are the chief exports, and probably the greatest of these are postage stamps.

The Virgin Islands form the fifth presidency of the Leeward Is., which is the reason why, small as they are, they beat Great Britain in one respect at least.

This is that they have two sets of postage stamps—their own particular set and one used in general by all the Leeward group.

The first Virgin Islands set was issued in 1866, in two values, which were somewhat crudely lithographed by



Waterlow and Sons Ltd. Many shades exist. There is an interesting variety in which the V in Virgin is slightly larger than the other letters of the word, and such a copy brings a good price, but 'ware forgeries! There is also a rare perforation variety, a superb copy of which would bring the best part of £100.

The design was changed in 1867, and until 1880 there were many printings. The varieties that resulted have made for a philatelists' playground, but we need not bother too much about these, beyond saying that while the catalogue value of a number of the classics is high, even genuine copies can be

picked up cheaply. But beware of these "bargains" also, for if they ever have to be sold, maybe it will then be found that after all they were not as well bought as had been imagined.

In 1880 the head of Queen Victoria appeared on



V.I. stamps for the first time. These stamps look very dull compared with the latest pictorial set, but there are collectors who will say that they prefer stamps thus. As a matter of fact, some perhaps really do, but if all stamps were what is known as the old key type, collectors would once more become very bored with them, as they were when the stamps were current. These key types remained current until 1909, when we got a delightful little set printed in recess by De La Rue. St. Ursula again provided the motif of the design. Five years afterwards we got the first set showing the head of Edward VII, while in 1919 George V was depicted.

The first K.G. set appeared in 1938. While there was an interesting change in the paper used, not a shade or a perforation variety appeared to gladden the hearts of all those collectors who are so keen on such things.

And now we come to the new set. Here we get more variety than in any set since Virgin Islands brought out its first stamps almost 90 years ago.

The 1c. shows a picture of the Sombrero Lighthouse, which is built on the outlying Sombrero Island. The 3c. and 5c. stamps show pastoral scenes, with sheep and cattle, but the palm trees that also appear

on these stamps prevent these views being taken for scenes at home.

Next we get a series of maps of the various islands. The 2c. shows Jost Van Dyke Island, the 4c. Anegada Island, the 8c. Virgin Gorda Island, the 12c. Tortola Island—where the capital, Road Town, is situated—and on the top value we get a map of all the Virgin Islands. Road Town from the sea is to be seen on the 2.40c. value, and—here is some of that romance mentioned previously—Dead Man's Chest Island on the 60c. and Sir Francis Drake Channel on the 1.20c. The Badge of the Presidency on the 2.4c. stamp completes the very fine set. Messrs. De La Rue are the printers and the stamps have been printed by the recess process.

This set of course will be classed with the K.G. VI group, which will make it more popular than ever, for these stamps are more sought after now than they were before the death of King George VI. While not all of us can afford a full set, several values, forming a short set that is quite representative, can be obtained for less than two shillings. Surely this provides an inducement to start collecting the stamps of the British Virgin Islands.



UNUSED NEW ZEALAND

A fine unused set of New Zealand Victory stamps showing Lake Matheson, King Geo. VI and Parliament, and St. Paul's Cathedral with the Union Jack in the background, a quotation from one of Mr. Churchill's great Battle of Britain speeches and the V sign, designs truly symbolising the sources of Peace, Strength and Victory, sent free to all applicants for approvals enclosing 2½d. postage.

★ Note new address Mention M.M.

R. D. HARRISON
20, PARK ROAD, HODDESDON, Herts.

1,000 STAMPS 6/6

ALL DIFFERENT. NO GREAT BRITAIN.

500, 3/-, 250, 1/6, 100, 9d.

BRITISH COLS.: 100, 1/3; 200, 3/3; 300, 6/6. TRIANGULARS: 10, 1/6; 25, 4/6; 50, 10/-; RAILWAY ENGINES: 15, 1/3; 25, 2/3; 50, 5/6. FLAGS: 10, 1/3; 25, 2/9. MAPS: 10, 1/3; 25, 2/9. SHIPS: 10, 1/-; 25, 2/3. AIRMAILS: 25, 1/6. POSTAGE 2½d. EXTRA.

Approvals and Catalogue of stamp bargains on request.
S. Tatlow & Sons, Eckington, Sheffield



FREE! This beautiful centenary stamp of Barbados FREE to all asking for our famous approvals and enclosing 3d. stamp.

FRANCIS CURTIS LTD. (MZ)

226, BAKER STREET, LONDON N.W.1

120 **U.S.A.** COMMEMORATIVES. S.G. Numbers 373, 375, 472, 831, 863AA, 878, 881, 882, 904A, 906, 907, 908, 909, 917, 918, 919, 921, 922, 927, 929, 932, 936, 937, 944 to 948, 981, 986, 987, 994, 995, 999, 1000, 1004, 1005, 1009, 1010, 1014, 1015, 1019, 1020, 1039, 1039A, 1072, 1077, 1078 to 1094, 1098 to 1104, 1106, 1108 to 1131, 1133, 1134, 1135, 1140 to 1161. S.G. 1952 U.S.A. 81 page Catalogue, 2/9.

FRED HARLOW 2, ROBINS WAY, SEVENOAKS, KENT

MYSTERY EXCHANGE PACKETS!

Exchange your "twicers" FREE from our guaranteed unsorted Free Exchange Packets which have circulated the World over. Different, profitable and interesting without payment. Details with 5 different NIGERIA also FREE with APPROVALS. ENCLOSE POSTAGE. Dealers Supplied. Overseas Agents Wanted.

ASTLEY & CO. (M)

103, CADMAN CRESCENT, WOLVERHAMPTON

Special offer of Rex Catalogue of King George VI Stamps Free. Over 450 illustrations; 6,600 Prices, with almost 150 pages.

Simply request my discount approvals and enclose sixpence in stamps to cover postage and packing. J. H. Abel, 53, Green Close, Sturminster Newton, Dorset

GREAT BRITAIN

Collector has accumulated duplicates for disposal from 60 years collecting, also oddments from abroad. Cheap selections on approval.

HILLIER — 35A, NORTHDOWN AVENUE — MARGATE

2/6 Post Free **DEALERS MIXTURE** **2/6** Post Free off Paper

Approximately 500 (Weighed) UNSORTED mixture. Good variety of old and new issues from numerous sources of supply. Constantly changing in contents. Abroad postage 1/- extra.

JOS. H. GAZE, 10, Picnic Road, CLITHEROE, Lancs.



G. P. KEEF — WILLINGDON — EASTBOURNE

FREE!

TO ALL COLLECTORS

4 STAMPS OF

GOLD COAST

BARGAIN - 50 CHINA 1/3

Send 2½d. Postage

NEW SET FREE

To all applicants for APPROVALS this month, enclosing 2½d. for postage, we will send FREE SET OF 3 VIRGIN IS. STAMPS JUST ISSUED.

Write as soon as possible to

GEM STAMP CO.

514, FAIRFAX DRIVE — WESTCLIFF — ESSEX

CEYLON PICTORIALS FREE

During July, approval applicants will be sent FREE the K.G. VI Ceylon Pictorial Set 10 values from 2c. to 50c. The stamps portray Elephants, Temple, Rice Field, Coconut Palms, Tea and Rubber Plantations, etc.

Send 2½d. stamp for postage.
H. B. LANG, BURNBANK, MAUCHLINE, Ayrshire

FREE GIFT OF STAMPS

to every applicant for approval books. THE GIFT contains 30 British Colonials including 8 K.G. VI mint—no Great Britain. Good discount is given and a list of 98 Gifts is sent. These can be chosen by you and vary in value according to the money sent for purchases. They include K.G. VI Silver Jubilees; ALL the Colonial Victory sets mint; and Foreign stamps. 3d. postage please.

C. A. RUSH, 38, Queen's Avenue, Whetstone, London N.20



(1 actual size)

FREE BURMA

Is this large mint pictorial in your album? If not, send 3d. postage and request approvals. Then it is yours! Illustrated gift list also free.

N. DARGUE (MB)

36, Gray Avenue, Murton, Co. Durham

YOUR DUPLICATES PROBLEM SOLVED

Details of genuine FREE EXCHANGE scheme post free. Approvals from 1d. upwards. Want Lists—let me help you with those elusive items. Just state countries and S.G. Cat. Nos. **A. DONNELLY (M), 1, ABINGDON ROAD, LUTON, BEDS.**

100 DIFFERENT STAMPS FREE

(including TRIANGULAR and PICTORIALS)

To Approval Applicants enclosing 2½d. postage. **N. JOHNSON (Dept. M.M.), 19, Hillside, Slough, Bucks.**

3,000 STAMPS FREE!!

Send 2½d. for details of this marvellous gift & approvals.

YEOMAN, 18, DEVON ROAD, HERSHAM, SURREY

FREE—STAMPS CATALOGUED 5/-

to applicants for 3d. approvals.
COX, 17, STONELEIGH PARK ROAD, EWELL

Stamp Gossip

A MILLION ORDERS

FOR some unaccountable reason the stamps issued last year by the United Nations have not caught on with British collectors. Dealers were able to get supplies, but one tells me that he has only sold half a dozen sets, though he stocked up, in anticipation of a rush that never came. It has been very different with American collectors, however, for these went for the stamps bald-headed,



personnel, and all worked for seven days a week.

Such figures are rather fantastic and it shows what a huge market there is in the U.S.A. for anything that takes the fancy of the population of that big country. There is a possibility that Q.E. stamps may later catch on to the same extent. Things are already shaping that way. Then indeed there will be some fun.

DAY OF THE STAMP

The Austrian Post Office is still at it, but as it produces such gems of stamps, who would have it otherwise? The latest—or one of the latest, for new ones are coming out all the time—is a stamp about stamps. A "Day of the Stamp" festival was held last December, but it was only in March that the philatelic tribute to that event appeared. The design shows Amor, or Eros, passing over the globe as a mail carrier, but there is an interesting point about the stamp and this is the reason why it is being illustrated. It will be noted that "Amor" is carrying a letter, a stamped letter, and the stamp, which shows clearly under a magnifying glass, is similar to the one that is being shown here. They do think them out in Austria.

Other than the magnifying glass, which is similar to the one that is being shown here. They do think them out in Austria.

POSTAL CENTENARY

One more set to add to the ever lengthening collection of stamps issued to commemorate stamps was released by Barbados on 15th April. Few sets will be more popular, for not only are the stamps of this West Indian colony much sought after in general, but the particular stamps that are being commemorated—a facsimile of one of which is incorporated in the design of the new set—are unique, for as will be noticed, only the name of the country

appears on the originals. When the commemorative set was first announced by the Crown Agents, we were told that facsimiles



in the original colours would appear on the new stamps. That part of the programme has not materialized, but we have been given an attractive set at a reasonable price.

There is a growing number of collectors who are taking up these stamps to commemorate stamps. If I may be allowed to give the tip, they are not likely to lose much cash by so doing.

NATO

I am afraid that collectors will not think much of Uncle Sam's philatelic contribution to the North Atlantic Treaty Organisation. As about 120,000,000 stamps similar to the one illustrated will be issued, it will be easy to obtain and will go into thousands of collections.



But really, something a bit better than this could surely have been turned out if it was felt that NATO deserved recognition at all. For instance, Portugal has also issued a couple of stamps in honour of the third anniversary, and they are relatively handsome affairs. Yet one would have to understand some Portuguese to recognise the object of the stamps, for instead of

"NATO" we get the synthetic word "OTAN," which stands for "Organizaçao de Tratado do Atlantico Norte." Surely a mouthfull! But the meaning is the same.

PICTORIALS OR NOT?

Indignant letters have appeared in the newspapers recently about the forthcoming postage stamps for Great Britain. Some want pictorials, similar to those issued by many of the colonies, while others want the old style to continue, with only the Monarch's portrait thereon. It will be letting out-go secret if it is mentioned that a little bird has whispered that there will be no pictures, though we can look forward to an attractive portrait of the Queen. There is nothing in the rumour apparently that portraits other than that of the Queen will appear on any of the values, though it will not surprise anyone if the Duke of Edinburgh and Prince Charles at least are shown, in due course, on the stamps of Australia and perhaps Canada.

A correspondent in Australia writes to say that the stamps of his own country will be the first with a new philatelic picture of the Queen, and it has already been mentioned in Parliament that before the end of this year we ourselves will have Queen Elizabeth stamps. So it won't be long now.

At the present moment the stamps of King George VI are more popular than ever, which is perhaps understandable, for collectors naturally wish to fill in those blanks before the stamps needed rise further in price. It is true that some K.G. VI stamps, like "Royal Visits," "Victory" issues, etc., are still almost in the doldrums, for far too many were bought at the time they were on sale. But in time these will be absorbed, and prices will rise, though not just yet.



From Our Readers

This page is reserved for articles from our readers. Contributions not exceeding 500 words in length are invited on any subject of which the writer has special knowledge or experience. These should be written neatly on one side of the paper only, and should be accompanied if possible by original photographs for use as illustrations. Articles published will be paid for. Statements in articles submitted are accepted as being sent in good faith, but the Editor takes no responsibility for their accuracy.

LONDON'S NEW COACHES

Replacement of London Transport's fleet of Green Line coaches is now well under way, and the accompanying illustration shows one of the new vehicles. These are classed R.F. and are powered by A.E.C. Regal Mk. IV underfloor oil engines. The bodies, which are full-fronted and of all-metal construction, are being built by Metropolitan-Cammell Carriage and Wagon Co. Ltd. and seat 39 people. They are 7 ft. 6 in. wide, with a total length of 30 ft. The entrance is placed as far forward as possible so that every inch of space can be used.

The vehicles are mostly replacing the 10/T/10 or T type Green Line Coaches, which were built in 1938 and have A.E.C. oil engines. These have had varied careers. When Green Line services were withdrawn during the war some became ambulances, and later on, American Red Cross Club Mobiles, while others were used on country routes. Those no longer required for coach work are being painted red for service on ordinary bus routes on which single deckers are run.

MICHAEL E. EDWARDS (Hounslow).



London Transport's new R.F. type coach. Photograph by M. E. Edwards.

TELESCOPIC LAMP POSTS IN PARIS

The four lamp posts on the Pont du Carrousel in Paris are quite astonishing, for they are raised at night and lowered every morning so as not to obstruct the fine roof-line of the Louvre. The lamps, so characteristic of the French people, provide adequate light for the fast Parisian motor traffic.

They are works of art, these handsome pillars of bronze. In the daytime they are nearly 42 ft. high and they are raised almost 24 ft. higher at night. On top is a great lantern, 8 ft. 3 in. in height, which houses three lights set at an angle, one above the other. It was found necessary to raise the lights so high at night because at their daytime level they were too dazzling for traffic.

Each lamp post is square in section, and lights in the bowls round the lower part illuminate the fine workmanship of the fluted bronze pillars during the dark hours. Their architect was M. Raymond Subes, who designed the wonderful Sevres porcelain service that was one of our present Queen's wedding gifts.

The upper and movable part of each lamp post is a plain square mast held together with angle irons. It weighs over 2½ tons, and rests on the inside framework of the lower fixed part with the support of sixteen live rollers.

Vertical chains run down the angles to the operating gear inside the concrete chamber on which each lamp post stands. This houses a 5 h.p. single phase motor, which drives a windlass that acts on two sprocket chains, each of which passes over a return roller, one at the base and one at the top of the fixed pylon. The motor is operated by the high frequency current used for the Paris street lighting. Switches at the top and bottom are directly worked by the windlass and automatically arrest the raising and lowering of the lamps, an operation that takes a little more than three minutes.

The pillars were ready to erect just before the war, but were quickly hidden—and that under the very bridge they were to adorn—when the Germans approached the capital. There they remained until at last the enemy were driven out again at the Liberation.

M. LITTLEDALE (Bournemouth).

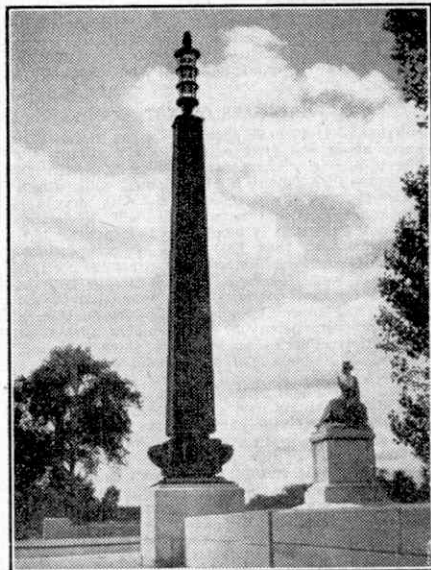

One of the fine bronze lamp posts on the Pont du Carrousel in Paris. Photograph by M. Littledale.

Competitions! Open To All Readers

Prize-winning entries in "M.M." competitions become the property of Meccano Ltd. Unsuccessful entries in photographic, drawing and similar contests will be returned if suitable stamped addressed envelopes or wrappers are enclosed with them.

An Easy Crossword Puzzle

CLUES ACROSS

1. Precise
6. Urge
9. Destroy
10. Summit
11. Put down suddenly
13. North Indian tree
15. Try out
17. Merriment
18. Walk heavily
19. Denial
21. Turkish measure of weight
23. Pasture
26. Slack
29. Colour
30. Rodent
31. Farther down
34. Ornament
36. Go astray
38. Remove
40. Foreign
41. Skill
43. Object of worship
45. Mischievous child
46. Cord
47. Unharmed
48. Assert
49. Source of plants

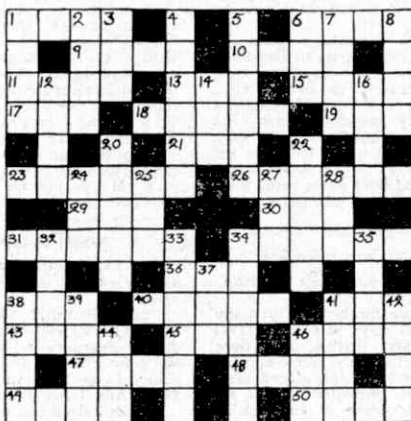

50. Colours cloth

46. Guided

CLUES DOWN

1. Gust of wind
2. Metal
3. Shows the way
4. To give
5. Pilgrim from the Holy Land
6. Obtain
7. Cattle
8. Obligation
12. Fresh-water Fish
14. Sea-bird
16. Without
20. Expert
22. Collect
24. Exist
25. Poem
27. Period
28. Possessive
32. Girl's Name
33. Depended upon
34. Ensnare
35. Deserve
37. Edge
38. Borders
39. Portion
41. Lighthearted
42. Rip
44. Youth

This month we present another of our popular crossword puzzles. There are no traps in the clues, or alternative solutions, and every word used, apart from names, can be found in a standard dictionary.

There are two sections in the competition, for Home and Overseas readers respectively, and in each prizes of 21/-, 15/- and 10/6 will be awarded for the best solutions. If

necessary the judges will take neatness and novelty into consideration when making their decisions. Do not cut out the diagram. Make a copy for your entry.

Entries should be addressed "July Crossword, Meccano Magazine, Binns Road, Liverpool 13." The closing date in the Home Section is 30th August, and in the Overseas Section, 29th November.

Can You Plan a Hornby-Dublo Layout?

This month we present the second of our model railway layout planning competitions, and this time it is for owners of Hornby-Dublo trains. We invite these enthusiasts to design a layout that will fit a space 8 ft. by 4 ft., using only track components within our current Hornby-Dublo range. In addition to showing the actual track layout, the positions of stations, signal cabins and signals should be indicated. Drawings can either be in ink or in colour. The judges will be particularly interested in the operating possibilities of the layout submitted, but neatness and originality also will be taken into account. A list of rails and other accessories required for the layout should be supplied with each diagram.

As usual there will be two sections, for readers at home and overseas respectively, and in each prizes of the value of 21/-, 15/- and 10/6 will be awarded for the three best entries in order of merit, together with consolation prizes for other good efforts. Competitors must remember to put their ages as well as their names and addresses on their entries, and envelopes containing entries should be marked "July Hornby-Dublo Layout Planning Contest, Meccano

Magazine, Binns Road, Liverpool 13." The closing date in the Home Section is 30th August, and in the Overseas Section, 29th November.

July Photographic Contest

The seventh of our 1952 series of photographic contests is a general one in which we invite readers to submit prints of any subject. Each competitor may submit only one photograph, which must have been taken by him, and on the back of his print must be stated exactly what the photograph represents; also his age must be given.

The competition will be in two sections, A for readers aged 16 and over, and B for those under 16. Each competitor must state in which section his photograph is entered. There will be separate overseas sections, and in each section prizes of 21/-, 15/- and 10/6 will be awarded. Entries should be addressed "July Photographic Contest, Meccano Magazine, Binns Road, Liverpool 13." The closing date in the Home Section is 31st July, and in the Overseas Section, 31st October.

Competitors who desire their entries to be returned should read carefully the paragraph at the head of this page.

The Short "Sealand"—(Continued from page 294)

folding card-tables and deep, turquoise-upholstered armchairs.

Such a standard of luxury would have been no use to poor little PK-CMA, for the sort of passengers she had to carry were men of the warlike Dyak nation, who invariably wear a short and extremely sharp scimitar, from which they are never parted. As a result, the first thing that happens when they sit down in an aircraft is that these ferocious weapons pierce the upholstery, and by the time the flight is over the constant movement quite often succeeds in slashing the seat to ribbons.

Fortunately, the "Sealand's" versatility enables it to take in its stride everything from Dyaks to duchesses, litters to lettuces, by land, sea or air, anywhere from the ice of Norway to the tropics. In an age when flying boats are out of fashion, it proves how disastrous it would be if we built only aeroplanes that need acres of concrete from which to take off. And, in doing so, it shows what a good thing it might be if the Air Ministry bought some "Sealands," so that a percentage of Coastal Command's ex-flying boat pilots could keep their hand in, just in case the people who see a future for flying boats are right after all!

Private Decorations—(Continued from page 304)

survivors from the wrecked hospital ship "Rohilla" at considerable personal risk.

The story of private medals for heroism actually goes back beyond the earliest days of official naval and military awards. The first British decorations were conferred by private individuals and corporate bodies. The Victoria Cross was not introduced until 1856, but the East India Co. presented medals for heroism in protecting their property as far back as 1791. A campaign medal in connection with the Battle of the Nile, in 1798, was given by Nelson's prize agent, A. Davidson, at his own expense.

New Meccano Models—(Continued from page 321)

Strip from the Face Plate. The Rod carries also four Compression Springs and a Collar, and on its lower end another Collar 9.

A 1" x 1/2" Angle Bracket 10 is bolted to the Flanged Plate, and together with a second similar part 11, prevents the Rack Strip from leaving the teeth of the Pinion.

The balance is calibrated by placing a series of correct weights on it and then marking on the dial the positions taken up by the pointer.



D. W. Swindells, Leeds.

whizzed in succession between two plates set at such a distance apart that only one can pass through at a time. Its use clearly will save a considerable time in banks, where more treasury notes have to be counted every day than most of us are ever likely to own.

Counting Notes by Machinery

How many pound notes could you count in an hour? Few of us will ever get a chance of finding out, but we should probably fall far behind an experienced bank cashier, who is said to be capable of counting five thousand in that time. He in turn is well-beaten by a machine that can run them through and record their number three times as quickly.

In this machine, now being made in Great Britain, the notes are

Right This Time!

On this page are portraits of A. H. Spinks, Liverpool and D. W. Swindells, Leeds, both prize-winners in our October "General" Competition. The two portraits appeared in the announcement of the results of this contest in the May "M.M." but inadvertently the captions were exchanged. This time we have got them right, and we hope that this will compensate the two competitors for their disappointment when the May issue appeared.



A. H. Spinks, Liverpool.

Wheel Rotates Once in Four Years

The owner of a Swiss calendar chronograph was greatly excited on the last day of February of this year.

"Look at this," he said, pointing to one of the dials of his watch. "For the last three years on the last day of February it has registered the 28th and then the pointer has moved on to the first of March. Now comes Leap Year and the hand is pointing to the 29th. And I haven't adjusted it either."

It was indeed the watch itself that had taken care of this extra day. Its mechanism includes a tiny wheel that has only one mission in life—to register the 29th of February once every four years. It actually turns round just once only in that interval, completing its full revolution punctually on the 29th of February in leap year, when this extra day is slipped into our calendar.

The particular watch that aroused this excitement shows also the phases of the moon and incorporates a stop watch that measures times to an accuracy of a fifth of a second.

This Month's Special Articles

	Page
Riding a Southern Main Line Diesel	290
by S. C. Townroe	
The Short "Sealand" ..	292
by John W. R. Taylor	
Training Centre with a Homely Touch	295
Portugal's Largest Bridge ..	296
Festiniog "Toy Railway" ..	299
by E. V. Clayton	
Model Yacht Racing	300
by H. C. Hirst	
Private Decorations	302
by Arthur Nettleton	
Trains that Record their Own Passage	308
by H. C. Towers, M.I.E.E.	
Robert Forrester Mushet ..	310
by E. N. Simons	

Fireside Fun

"What ya doing, Ma?" asked the cowboy.
 "Knitting a gun, boy."
 "That won't be much use, will it, Ma?"
 "Yes, it will. I'm using steel wool."



"Morris minor, take a hundred lines for talking."
 "But I wasn't talking, Sir."
 "Then make it two hundred for deceiving me."

She saw a car rolling slowly along the street, without a driver at the wheel. Bravely she jumped in and applied the brakes.

Then a man came round the car.

"Is this your car?" she asked.

"Yes, it is," he replied.

"Do you know it was running away?"

"Well, yes. I've run out of petrol and was pushing it to a garage until you stopped me."

"My word, your boy is growing, isn't he?"

"Rather. A year or two ago he wore my old suits and now I wear his."

"I wish things were not always the wrong way round."

"What's the matter now?"

"Well, you know these vitamins we all have to take nowadays?"

"Yes, what about them?"

"Why didn't they find them in cakes and buns instead of things like cod liver oil?"

"Does your husband like home cooking?"

"He does! We always dine at a restaurant that makes a speciality of it."



"Who's waiting at this table?"
 "Looks like you are!"

BRAIN TEASERS EASY AS A.B.C.

Here is yet another arithmetic sum in letters, this time a very easy looking piece of multiplication. As usual, the problem is to replace the letters by numbers and so to restore the original.

$$\begin{array}{r} \text{ABC} \\ \text{AC} \\ \hline \text{BDAC} \\ \text{CGEC} \\ \hline \text{CCGFC} \end{array}$$

WEIGHING BY INSTALMENTS

A coal merchant wished to find how much coal there was on one of his lorries, but the platform of the weighing machine that he used was not long enough to take the whole of the lorry. He decided to find the weight shown on the machine, first with the rear wheels only on the platform and second with just the front wheels on it. Adding these, he thought, would give the correct weight. Was he right?

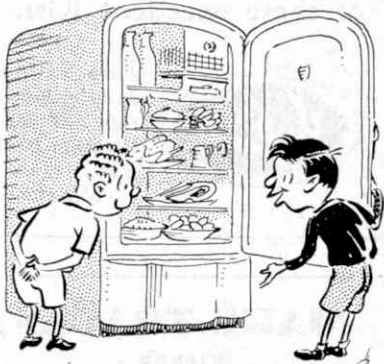

"My Dad doesn't say 'What's cooking?' any more. He stands here when he comes in and says 'What's thawing?'"

SQUARE DEAL FOR TREES

A square pond was not big enough, but at each corner there was a tree that the owner did not wish to remove. After thinking a few minutes he found a way of doubling the area of the pond while leaving the trees in the same positions, and the new pond was square. How was this done?

SOLUTIONS TO LAST MONTH'S PUZZLES

The six words of our June pyramid are O, OG, DOG, DOGE, LODGE and GOLDEN.

The cars of our second puzzle were SOMERSET, JAVELIN, CONSUL, SUPER SNIPE, OXFORD, SILVER WRAITH, WYVERN and MAYFLOWER.

The new girdle round the Earth suggested in our third puzzle last month would have a circumference 22 ft. longer than that of the Earth. Its diameter therefore would be longer by 22 ft. divided by π , which we can take to be 22/7. Thus the diameter of the girdle would be 7 ft. longer than that of the Earth, so that it would stand 3 ft. 6 in. above the Earth's surface. Whether this girdle were put round the Earth or a cricket ball the result would be just the same; it would be 3 ft. 6 in. above the surface.

The message conveyed in code in our last puzzle is a very simple but very acceptable one, "FIRESIDE FUN, A REGULAR FEATURE IN 'MECCANO MAGAZINE,' THE POPULAR MONTHLY JOURNAL."

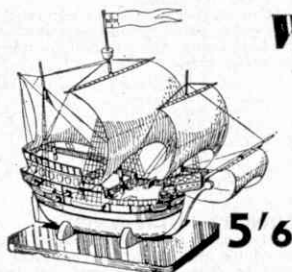

THE MARY FORTUNE
Kit No. 2914

Why not make these Miniature Galleons?

Making models of old-time ships from Hobbies Kits is one of the most absorbing of all pastimes—and it's inexpensive, too. Only a fretsaw and a few tools are needed, and even the amateur will not find the work difficult. The Kits are complete with all wood and necessary parts—and step-by-step instructions. You can't go wrong.

Start to-day by getting one
of these excellent Kits.



From Stores, Ironmongers and
Hobbies Branches, or post free
from Hobbies Ltd., Dept. 96,
Dereham, Norfolk. Illustrated
leaflets of our complete range
obtainable on request.



THE 3d GALLEON
Kit No. 2778

MAKE TRACKS FOR PECOWAY

If you are on holiday near Seaton, why not call in at PECOWAY and see for yourself the wonderful PECO Track, Couplings and other products there displayed. Bring along your OO Loco. and give it a run on our test track—we can provide a train that really will test its capabilities!

If you can't visit us, then our NEW CATALOGUE AND GUIDE is the best way of assessing our products. Send a 1/6 P.O. to the PECO TECHNICAL ADVICE BUREAU, Pecoway, Station Road, Seaton, Devon.

THE PRITCHARD PATENT PRODUCT CO. LTD.
PECOWAY, STATION ROAD, SEATON, DEVON

ASTRA

COLOUR ★ SEARCH LIGHTS
LIGHT GUNS
SIGNALS ★

ASTRA No. 18
3.7 A.A. GUN

Price 42/-
Plus P.T. 9/1



The No. 18 3.7 A.A. Gun shown above, is the most famous of the Astra Range: A magnificent working Model, weighing 4½ lbs. It does all the things that a real Gun does, including elevating and traversing. The Gun is fitted with breech locking mechanism and a range finder. This splendid Model will fire with or without Caps. Supplies are limited, so make sure of yours now.

FROM ALL GOOD TOYSHOPS

Sole Patentees and Manufacturers:

ASTRA PHAROS LTD.
LANDOR WORKS, ASKEW ROAD, LONDON W.12

THE FUTURE IS YOURS PREPARE FOR IT NOW

Maximum production, on which the life of the nation rests, depends on high technical skill. This gives marvellous opportunities to young men who have acquired such knowledge and efficiency as that contained in an I.C.S. Course of Instruction.

THE DEMAND FOR WELL-TRAINED MEN IS URGENT AND UNLIMITED — BUT THERE IS NO WORTH-WHILE PLACE FOR THE UNTRAINED

If you need technical training, our advice on any matter concerning your work and your career is yours for the asking—free and without obligation. Let us send you full information regarding the subject in which you are specially interested. **DON'T DELAY.** Make **ACTION** your watchword.

The successful man **DOES** to-day what the failure **INTENDS** doing to-morrow. Write to us **TO-DAY.**

Fees are moderate and include **ALL** books required.

Generous Discount to H.M. Forces

Dept. 126A, I.C.S., 71, Kingsway, W.C.2

----- YOU MAY USE THIS COUPON -----

(1½d. stamp on unsealed envelope)

INTERNATIONAL CORRESPONDENCE SCHOOLS LTD.

Dept. 126A, International Buildings, Kingsway, London W.C.2

Please send booklet on subject.....

Name..... Age.....

(BLOCK LETTERS PLEASE)

Address.....

The I.C.S. offer Courses of Instruction in a wide range of subjects, including:

Accountancy	Illumination Engineering
Advertising	Journalism (Free Lance)
Copy Writing	Machine Designing
Advertising Management	Maintenance Engineering
Architecture	Marine Engineering
Boiler Engineering	Mechanical Drawing
Book-keeping	Mechanical Engineering
Building	Mine Surveying
Business Training	Mining Electrical
Business Management	Motor Engineering
Carpentry and Joinery	Production Engineering
Chemical Engineering	Quantity Surveying
Chemistry, Org. & Inorg.	Radio Engineering
Civil Engineering	Radio Service Eng.
Coal Mining	Refrigeration
Commercial Art	Salesmanship
Concrete Engineering	Sales Management
Diesel Engineering	Sanitary Engineering
Draughtsmanship	Sheet-Metal Work
Drawing Office Practice	Short-Story Writing
Electrical Engineering	Steam Engineering
Eng. Shop Practice	Structural Steelwork
Farming (Arable and Livestock)	Surveying
Fire Engineering	Television Technology
Foremanship	Toolmaking
Heating and Ventilation	Welding, Gas and Elec.
Horticulture	Woodworking Drawing
Hydraulic Engineering	Works Engineering
	Works Management

And most of the Technical, Professional, Commercial, Educational and Civil Service Exams., also for General Certificate of Education.

(Examination students are coached till successful.)



Develop your own holiday snapshots

Doing the work yourself is half the fun of photography. You save money and have no end of a thrill in making the negatives and getting a few prints from them. It's quicker, too. You see the results within a few hours of taking the snaps. Start, right away, by sending for this five shilling trial set.

It comprises

- 1-oz. (25 cc.) bottle of the famous AZOL developer.
- 4-oz. tin of Acid Fixing salts.
- 2 M-Q Pactums, print developer.
- 1-oz. (25 cc.) bottle of 142.
- 25 sheets of Contact paper, size $2\frac{1}{2} \times 3\frac{1}{2}$ inches and the instruction book which tells you how it is all done.

PRICE
5/-

includes the purchase tax, packing & postage.

Enclose P.O. Write your name and address in block capital letters and mark the front of the envelope clearly **MECCANO MAGAZINE**



NEW HOME PHOTOGRAPHY

You should read this book. Nearly 100 pages, 130 illustrations. Packed with all sorts of useful hints and dodges for getting good results. Get a copy today. It will help you to make better snapshots. Your dealer sells it, or a copy will be sent, post free, for 2/6. Enclose P.O. Write name and address in capitals and mark envelope **MECCANO MAGAZINE**

ONLY ONE trial set can be sent under this offer. When the chemicals are used up go to the photographic dealer from whom you buy your films. He keeps a stock of everything you are likely to need and will be able to help you with much useful advice.

JOHNSONS OF HENDON LTD., LONDON N.W.4

THIS MONTH'S OFFERS

BY **ELECTRADIX** ESTD. 1920

MORSE PRACTICE SET. Surplus stock, as new, comprising A.M. Morse Key, well balanced, precision made, with heavy insulated knob and solid contacts, twin-coil Buzzer of robust design mounted on base and wired. Space for battery. 7/6, plus 1/- postage.

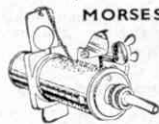

MORSE SIGNAL LAMPS. Ideal for campers, light and easily carried. Metal body, 6 in. long, $1\frac{1}{2}$ in. dia., crackle finish, fitted lens and slide with 3 colour filters, key, lamp holder for flash-lamp bulb, all new. 8/6 each. Two for 15/- post paid.

CRYSTAL SETS. The Lesdix 1952 Model, litz-wound coil, var. tuning condenser, Diode Detector, 'phone transformer with socket, all in bakelite case, 6 in. x $4\frac{1}{2}$ in. x $1\frac{1}{2}$ in., supplied with headphones, fitted cord and plug, all aerial tested, 30/-, post 1/6. Crystal set only, 21/-, post 1/-.

DIMMING RESISTANCES for 12-v. circuits, 100 ohms, $\frac{1}{2}$ amp., totally enclosed, 2/6, post 6d. Open type, 10 ohm, 1 amp., 2/6, post 6d.

MAGNETS. D.C. Electro magnets, 6 volts, lift 4 lb., twin coil, new surplus, 5/-, post 6d.

MICROPHONE BUTTONS. 1 in. carbon granule type with almost a hundred uses; send for descriptive leaflet, 3/6 each. Transformer, 2/6, post 9d.

Write Dept. E.

ELECTRADIX RADIOS
214, Queenstown Road, Battersea, S.W.8

Telephone: MACaulay 2159

LOTT'S Chemistry

Convert your chemistry set to a student's laboratory by easy stages.

Supplies of spare apparatus and chemicals are now available.

Also Lott's Stone Puzzle together with free book of 105 problems.

Ask to see them at your dealer or write to the manufacturers for current price list, enclosing stamped, enclosing addressed envelope 13d.

A SMALL SELECTION FROM OUR LIST



LOTT'S BRICKS LTD
(Dept. M.M. 4) WATFORD · HERTS

4 NEW DATA SHEETS

for
Engineering Students
and Apprentices, etc.

The above set now includes sheets on ADJUSTABLE MICROMETERS, CALLIPERS and DIVIDERS and two more EQUIVALENT CHARTS, making 20 Sheets in all.

These sets of drawings show methods of using and applications of certain tools detailing the more important Moore & Wright Precision Hand Tools. They also include Charts for Decimal Equivalents, Drill Sizes and Tapping and Clearance Drills.

The sheets in each set are in blueprint form, 8 in. x 10 in. notebook size, and punched to fit a special binder which is also supplied, and into which loose-leaf note paper can be fastened to make the binder into a very comprehensive notebook. If the folder is kept up to date, together with your own notes it will be a very valuable Compendium of Engineers' Precision Tools.

RETAIL PRICES:
Complete with Binder 5/3 per set
Separate Sheets 3d. ea. Binders only 1/6 ea.

Please apply to your usual Tool Dealer or to:
MOORE & WRIGHT (SHEFFIELD) LTD
14/28, Norton Lane, Meadowhead, Sheffield B

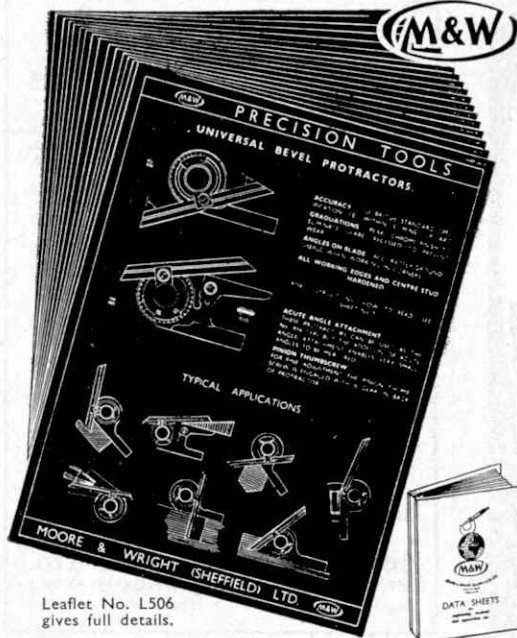

Leaflet No. L506
gives full details.



VITALITY PRISMATIC

CYCLE DYNAMO BULBS

Give a smooth beam of light—
no dark spots.
**ALL PRICES THE SAME AS
FOR CLEAR BULBS**



Ref.	RATING		BALLOON		Cap	Price Exc. P.T.
	Volts	Amps/Watts	Size	Shape		
FOR USE WITH LUCAS AND MILLER						
3	6	0.5-3.0	18 mm.	Ball	S.B.C.S.C.	1s. 4d.
963	6	0.3-1.8	18 mm.	Ball	S.B.C.S.C.	1s. 4d.
9	6	1.0-6.0	18 mm.	Ball	S.B.C.S.C.	1s. 4d.

Special Types for use with RALEIGH DYNOHUBS Of High Light Efficiency and should only be used upon Raleigh						
86	6	0.2-1.2	15 mm.	Ball	M.E.S.	9d.
87	6	0.25-1.5	15 mm.	Ball	M.E.S.	9d.
88	6	0.3-1.8	15 mm.	Ball	M.E.S.	9d.

FOR MOST OTHER MAKES OF CYCLE DYNAMOS						
43	4	3-1.2	15 mm.	Ball	M.E.S.	9d.
44	4	3.5-1.4	15 mm.	Ball	M.E.S.	9d.
46	4.5	3.5-1.575	15 mm.	Ball	M.E.S.	9d.
48	6	2.5-1.5	15 mm.	Ball	M.E.S.	9d.
49	6	3-1.8	15 mm.	Ball	M.E.S.	9d.
50	6	3.5-2.1	15 mm.	Ball	M.E.S.	9d.
51	6	4.5-2.7	15 mm.	Ball	M.E.S.	9d.
52	6	5-3.0	15 mm.	Ball	M.E.S.	9d.
53	6	5.5-3.3	15 mm.	Ball	M.E.S.	9d.
55	6	1.0-6.0	15 mm.	Ball	M.E.S.	9d.

Sold by Curry's and most leading cycle agents, if unable to secure send covering cost with the name and address of your usual supplier to **Messrs. VITALITY BULBS LTD. (Dept. M.), NEVILLE HOUSE, NEVILLE PLACE, WOOD GREEN, N.22**

A DIRECT HIT!

with the
'GLENBUR' MECHANICAL TORPEDO

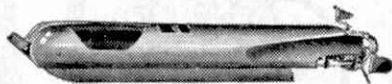

This power-driven watercraft, incorporating its own mechanical winding-gear has a range of up to 30 feet and produces a most realistic effect on impact with its target. The Torpedo-head is quite harmless and is released by a simple spring action.

Overall length 10"—supplied complete with spare power-bands and lubricant—it provides endless fun for all ages.

PRICE 13/11

(Postage/Packing 9d. extra)

Order now, sending postal order to:—

GLEN-BURROUGHS & Company Limited
FORMBY, LANCs., ENGLAND



Be like the champion-



...cycle on
DUNLOP
 TYRES
 Chosen by Reg Harris

1H/342

BOND'S

**Limited Supplies of Trix "00" Trains
 are now available**

Trix Goods Train Set No. 1/324 comprising locomotive and tender with 4 goods wagons, controller, plugs and wire .. Price **£7 3s. 6d.**

Trix Passenger Train Set No. 1/334 comprising locomotive and tender with 3 bogie coaches, controller, plugs and wire .. Price **£8 2s. 6d.**

Trix Oval track formation No. 915, making up an oval $42\frac{1}{2}$ in. x $28\frac{1}{2}$ in. .. Price **£2 14s. 9d.**

Trix Straight rails No. 420/1 .. Price **2s. 8d.** each

Trix Curved rails No. 410/1 .. Price **2s. 8d.** each

Trix Points, hand operated No. 442 Price **37s. 6d.** pair

Trix Points, remote control with fittings, No. 445 Price **62s.** pair

Trix Transformers, specially made to run 2 trains, No. 455/240 Price **60s. 10d.** each

Trix Controllers with automatic cut-out No. 472 Price **36s.** each

All goods offered subject to being unsold. Prices are plus packing and postage.

BOND'S O' EUSTON ROAD LTD.
 357, EUSTON ROAD, LONDON N.W.1
 Est. 1887 'Phone: EUSton 5441-

WILSON'S LORRIES LTD.

Dept. M

6, Gt. Winchester St., London E.C.2



BUILD YOUR OWN
 4 mm. and 7 mm. lorry kits

Send for
ILLUSTRATED CATALOGUE
 8d. post free

24 "no-tools-to-make-em" outfits
 and a host of Spare Parts

"00" GAUGE LINESIDE KITS FOR PERFECTION IN REALISM

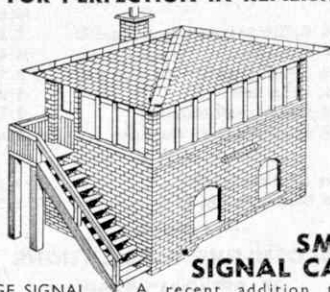

SMALL SIGNAL CABIN

LARGE SIGNAL CABIN .. 4/7
WATER TOWERS (2 types in 1 kit) .. 2/9
COUNTRY STATION 5/6
PLATFORMS 3/8
FOOTBRIDGE 2/9
LARGE GOODS STATION 6/5

Postage: Single kit 6d. (two or more 10d.)

A recent addition to the "Lineside" range which is finding great popularity amongst "00" enthusiasts. Accurately scaled. Kit contents include printed card and wood parts, printed celluloid windows, detailed authentic plans, brick and tile building papers.

Inc. Purchase Tax **3/8**

SOMETHING NEW

A set of 12 miniature posters beautifully printed in full colour. 4d. per set inc. Purchase Tax. Postage 2d.

MODEL-CRAFT

77 (H), GROSVENOR RD., LONDON S.W.1

DÜBOIL

SCALE LUBRICATION
THE PERFECT OIL

for

Meccano Gears — Hornby Trains
Dinky Toys and all Model Equipment

RECOMMENDED

by

The Watch and Clock Trade
YOUR LOCAL DEALER
WILL HAVE IT

Bottled and Distributed by

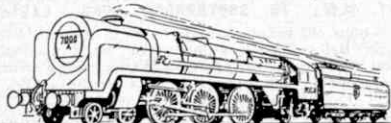

GEORGE BRADSHAW

5 & 6 WESTERN ROAD HOVE · SUSSEX



AND EVEN DAD
WON'T BE ABLE TO RESIST THEM



CAPPIT: A game for 2-4 players, who try to "Catch and Cap" their opponents. As easy as ludo, but how much more exciting! **9/-**



TELL ME: The queen of quiz games. Spin the wheel and roll out the questions! Endless fun for any age. Any number of players, the very thing for your party. **7/6**

If your dealer cannot supply, write for address of nearest stockist to:

J. W. SPEAR & SONS LTD.
DEPT. M • ENFIELD • MIDDLESEX

A CLOCKWORK BOAT

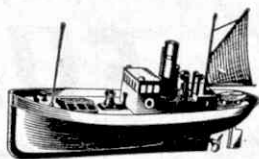

FOR ONLY 6/6

This is a realistic model (7½ inches long) of a Lowestoft drifter—the sort that brings back huge catches from the North Sea fishing grounds. The detailed deck fittings include a mast and sail, a winch and capstan, ventilators—and even a tiny lifeboat! The clockwork motor runs for over a minute, drives the boat over 30 feet on one winding. And the price is a surprise at only 6/6 plus 1/- for packing and postage. Send off to-day!

Hamleys

ESTD 1780
HAMLEY BROTHERS LTD

200-202, REGENT ST., LONDON W.1
(Our only address) Telephone: REGent 3161

BOOKS:

"00 Layout and Design"	3/6
"Fowler, Ivatt, Stanier L.M.S. Locos."	7/6
"New Developments in Railway Modelling"	15/-

RAILWAY ACCESSORIES:

Plastic Grey Stone Walls, 8 in.	11d.	11d.
Plastic Haystacks	1/4	—
Tunnel Mouth, S/L	3/2	—
Sheet L.M.R. or S.R. Station Signs	7d.	—
Sheet Station Notices	2 1/2	7d.
Six Plastic Sacks, assorted	1 1/2	1/9

POSTCARDS:

(Loco. and Train): Coopers L.M.R. list/card	9d.
G.W.R., L.N.E., and S.R. list and card	9d.
Special selection: Loco. and Train Postcards (usually 4/-), per half dozen	2/-
Postage extra "00" or "00" Parts List 6d. per post.	

TYLDESLEY & HOLBROOK (M.E.T.A.)
109, DEANSGATE, MANCHESTER 3

WEBLEY AIR PISTOLS

Marvellously accurate for target practice

No licence required to purchase for use on enclosed premises.

Senior Mark I
Junior Webley Air Rifle



Write for list. WEBLEY & SCOTT LTD.,
87, Weaman Street, Birmingham, Eng.

W.S.S.R.

Latest *San Allan* Books

	each
A.B.C. British Locomotives (4 Regions)	2/2
Service Suspended	2/8
A.B.C. British Road Services (New Ed.)	2/2
A.B.C. Motor Cars	2/2
A.B.C. Civil Aircraft Markings	2/8
A.B.C. Military Aircraft Markings	2/8

Trains Illustrated, July	1/6
Buses Illustrated, No. 11	2/6

LOCOMOTIVE PUBLICATIONS

32, APPROACH ROAD

LONDON BRIDGE, S.E.1

GENERAL CERTIFICATE

Wolsey Hall (founded 1894) provides successful postal tuition for the G.C. of E. exams. of London, Oxf., Camb., and the Northern Universities. Moderate fees, instalments. Prospectus (mention exam.) from C. D. Parker, M.A., LL.D., Dept. GK50,

WOLSEY HALL, OXFORD

LENS OF SUTTON 50, CARSHALTON ROAD, SUTTON, SURREY

Plenty of back numbers always available of "Meccano Magazines" 1933-1941, 9d. each; 1942-1949, 6d.; 1950 onwards, 9d. Also "Model Railway News," "Model Railway Constructor," "Model Engineer," all 6d. each. All "Buses Illustrateds," 1/6 each. "Trains Illustrateds" (Vol. 2—Dec. 1950), 1/- each; 1951 issues, 1/6 each. "Railway Magazines" pre-1942, 2/- each; 1942-date, 1/6. Glossy P.C.'s of Buses, Trains and Locos., 6d. each. Good clean mixed cigarette cards, 50 for 1/- Sets 1/6. Anything of a Railway nature bought, sold or exchanged.

PERSONAL ATTENTION MEANS A LOT TO THE MODELLER

We have the largest stock of model materials, aircraft and railway kits and accessories in the North. Your mail order by return. Send 4d. stamp for eight-page list.

WILMSLOW MODEL CO.

Water Lane, WILMSLOW, Cheshire

CIGARETTE CARDS

Send 6d. for CATALOGUE of 1,000 different series. Special offer 100 different cards 2/9. Albums to hold 200 cards 1/9 1/2. Dept. "M." E.H.W. Ltd., 42, Victoria St., London S.W.1

AMERICAN MAGAZINES

Subscriptions arranged for Popular Science, Model Railroader, Trains, etc. Popular Mechanics books available. S.A.E. Lists: PETER F. HOBSON. DEPT. M.M., 79, SOUTHBOOK ROAD, EXETER

2/6 buys 165 railway station views in three books—"British Railway Stations Illustrated," No. 1 (Cornwall, Devon, Somerset), No. 2 (North Wales), No. 3 (Kent, Surrey, Sussex), 2/6 per set of three books, postage 3d.—R. & T. P., 185, Nutfield Rd., South Merstham, Surrey.

CRYSTAL SET KITS 15/11 post free. Easily constructed. Endless entertainment and no further expense. Headphones 15/-, W. Buckle (Dept. M), 77, Horringer Rd., Bury St. Edmunds

Learn Shorthand by 1st Aug. (1 hour's study nightly). 1st lesson 2 1/2d. stamp. Duttons (Dept. MO), 92, Gt. Russell St., W.C.1

ALL-IN-ONE . . . WATERPROOF SLEEPING BAG

The Complete Sleeping Bag—needing no ground sheet, additional blankets or bedding.

- Underneath and sides rubberised waterproof material.
- Egyptian cotton top.
- Inside fitted warm and cosy double blanket; braided bound edges.
- Heavily proofed bolster case.
- Rolls up small—lightweight for carrying.
- Roomy throughout—size: 7 ft. 3 in. × 2 ft. 9 in.
- Wide opening for easy access.
- All made to Govt. standards.

Owing to restricted foreign travel allowance, camping holidays are more popular than ever this year, but camping goods are in short supply. To be sure of yours ORDER NOW.



45/-
Post and Packing 2/-

MADE FOR THE ROYAL NAVY

SANDALS 8/9

All leather, stitched sole and heel. Sizes 6-10 (no half sizes). Post & Packing: 1 pr. 1/3, 2 prs. 1/6, 3 or more Post Free.



Order by post with confidence. Money refunded if goods unsuitable. Remittance with order or C.O.D.

SCOTT & REED LTD.

(Dept. 600), Morris House, 1-5, Jermyn Street, London S.W.1

BOYS! It's selling in thousands! THE FAMOUS FLOATING SAFETY

KNIFE
The real floating dinghy knife as supplied for air-sea rescue. Secured by lanyard (2 yards) to solid leather sheath. Razor-edged blade running right through solid cork handle. Snub nose to guard against accidents. Has a thousand uses, especially for camping, boating, model making, etc. Brand New.

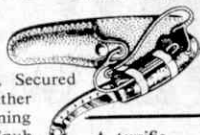

A terrific bargain at only **5/-** P. & P. 6d.

WHITE & KHAKI DRILL SHORTS



KHAKI 13/6
WHITE (Naval Pattern) 15/-

British pattern; short legs, close fitting, 3 pockets, adjustable fastenings, complete with buckles. Brand New. KHAKI: Waists 31-39. WHITE: Waists 28-40. Sanforized Shrunk.

P. & P. on either 1/3.

A New "Wayside and Woodland" Book FRESHWATER LIFE of the BRITISH ISLES

by John Clegg, of the Haslemere Educational Museum

This new book is one of the very few dealing with all aspects of freshwater life, and it is intended for those generally interested in the subject, as well as the serious student. Boys and girls who study pond-life will find it invaluable. ... **21s. net.**

FREDERICK WARNE & CO. LTD.
1-4, Bedford Court, London W.C.2

CHEMISTRY APPARATUS



Send 2½d. Stamp for latest **PRICE LIST**

BOOKLETS:
"Experiments" 10½d.
"Formulas" 10½d.
"Home Chemistry" 2/3
Post Paid

BECK (Scientific Dept. G), 60, High Street, STOKE NEWINGTON, LONDON N.15

Diana AIR GUNS and PISTOLS



For sport and practice in the open air (also indoors with the new Milbro Plastic Pellets).

From your local sports shop or if in any difficulty write

MILLARD BROTHERS LIMITED
Diana Works, Carfin, Lanarkshire, Scotland

THIS IS IT CHAPS! A SUPER SHEFFIELD SHEATH KNIFE



8 INCHES LONG from the tip of its hand-ground, razor-edged Sheffield steel blade to the tip of its polished wood handle, with brass guard and engraved blade; complete with leather sheath. Also PERFECTLY BALANCED 7½" THROWING KNIFE with beautifully engraved blade and unbreakable handle; complete with sheath 9/8. CRAFTSMAN-MADE BY WILLIAM RODGERS.

Robin's
MAILORDER SERVICE

DON'T MISS IT!

Post and packing on all knives 8d. extra.

5/4

(Dept. M.752), 100, EAST ST., LONDON S.E.17



When you visit SWITZERLAND

don't fail to see our displays of Toys and Souvenirs. We have eight large modern stores, the addresses of which are given below, at which you will find a welcome and an extensive selection of toys, novelties and souvenirs. You will be especially thrilled by our Technical Department, where an extensive railway layout is being operated throughout the year.

ZURICH
LUCERNE
LUGANO
LOCARNO
BERNE
BASLE
GENEVA
LAUSANNE

Bahnhofstrasse 62
Grendelstrasse 10
Via Nassa 5
Piazza Stazione
Marktgasse 40
Freiestrasse 28
12, Croix d'Or
23, Rue de Bourg

Franz Carl Weber

READERS' SALES AND WANTS SALES

Meccano Outfit No. 9, red and green, with extra Spares and 4 Motors. All in wooden boxes. Cost £16. Offers. Would exchange (or part) for Gram/Radiogram of Auto Change type.—Deeming, 20, Farnold Road, Yardley, Birmingham 26.

10 Trix Trucks, £3/10/-, 22 Dinky Toys as new £1/17/6. Also Trix Rails in good condition, Point, Crossing, £3/5/- lot, all in good condition; prices are sterling. S.A.E. for list.—Harrison, 7, Finn Street, O'Connor, Canberra, Australia.

Railway and Model Railway Magazines, S.A.E. for list.—G. A. Coaker, 24, Stompond Lane, Walton-on-Thames, Surrey.

Hornby-Dublo Electric Tank Locomotive, Rails and Accessories; cost £12; accept £10. Dinky Toys, "M.M.s" and "Model Railway News," value £8; accept £1/10/-. Request offers.—8, Putson Avenue, Hereford.

"M.M.s" 1934 to 1950 (1935 and 1944 to 1950 complete); few of other volumes missing; majority in excellent condition. Also "Practical Wireless," "Shortwave Magazine" and "Wireless World," 1947 to 1951; few missing. Offers, S.A.E.—Flory, 32, Marlow Avenue, Eastbourne, Sussex.

Hornby-Dublo Controller, Trix Left-hand Point, £1 each.—22, Lynton Avenue, Ealing, London W.13. Meccano Outfit No. 6, complete and extras, 30/-. "M.M.s" March 1945-December 1951, 2/6 per dozen.—Clegg, 12, Woodend Road, Stockport.

"Engineering Workshop Practice," Three Volumes printed by Caxton, unused, 30/-; Golf Club, 3/6; Pair of Raleigh Drop Handlebars in good condition, 5/-; B.S.A. "Club" Air Rifle with Case Pellets and Targets, perfect, £9/10/-; 0.22 Pellets, 3/- per 500; Golf Balls, 6d. each; Book on Morse Code; Telegraphy, etc., 3/-; S.A.E. to—D. Tillyer, 74, Greenway, Pinner, Middlesex.

30 Dinky Toys; S.A.E. for list.—R. Couvela, Hakesrill, Alexandria Road, Sidmouth.

MECCANO MAGAZINE

Registered at the G.P.O., London, for transmission by Canadian Magazine Post.

EDITORIAL AND ADVERTISING OFFICES:

LIVERPOOL 13, ENGLAND.

Telegrams: "Meccano, Liverpool."

Readers' Sales and Wants. Private advertisements (i.e., not trade) are charged 1d. per word, minimum 1/-. Cash with order. Readers' advertisements are published as soon as possible; inclusion in the first issue after receiving them cannot be guaranteed.

Private Collector wishes to sell cheaply main part of Stamp Collection, many bargains to be sold. Write immediately to—J. Foster, 45, Devonshire Avenue, Roundhay, Leeds 8.

Hornby Railway: Two Engines, Rails, Rolling Stock, £10. Will exchange for Hornby-Dublo.—A. Bedward, 1, Elizabeth Barrett Walk, Newton Aycliffe, Co. Durham.

WANTS

Very good prices given for any Super Model Leaflets and pre-war Manuals of the larger Meccano Models—D. S. Martell, 40, Park Avenue, Bedford.

Meccano Parts, two No. 7a, 18½ in. Angle Girders, one No. 132, Flywheel.—Turner, 115, Sidcup Hill, Sidcup, Kent.

Meccano Parts No. 168 Ball Bearing, and No. 167 Flanged Ring (two required). Details to—6, Raleigh Hall, Ecclehall, Staffs.

Hornby Clockwork Gauge 0 Turntable and any other Accessories.—Laird, 3, High Street, Marlow, Bucks.

Dinky Toys and Toy Soldiers any condition. Also Trix Trains, S.A.E. for particulars. Will answer all replies. Write—J. F. Tempone, 2621-92nd Street, Jackson Heights, L.I., New York, U.S.A.

STAMP ADVERTISEMENTS

(See also pages 328 and 330)

SOVIET RUSSIAN SET FREE

To all applicants for our bargain approvals we offer a brand new set of two giant multi-coloured pictorials showing huge map, etc., of South Russia. These stamps would immediately attract the attention of your friends if seen in YOUR collection. High discount or nearly 100 gifts available to regular customers. 23d. postage please. Special offers: 100 Br. Cols. all diff.—1/9, 25 Israel 5/-, 50 Roumania 1/6. Cash with order.

MARSH & MORRIS (MR), 89, ALMA RD., BRISTOL 8

FREE Princess Elizabeth FREE

visit to Malta
No collection can be complete without this stamp. Write for approvals when this stamp will be sent free enclosing 2½d. stamp for postage.

BEDFORD & CO., (Dept. M)

123, Conybere St., BIRMINGHAM 12



A MONSTER APPROVAL PACKET!

1,000 STAMPS, on approval, pick 1d. each. (Farrishing each!)

Send for a packet NOW!

BALDWIN, (Postal only), 28, COUNCIL STREET, EBBW VALE, MONMOUTHSHIRE

TANNA TOUVA Giants, Triangles, Diamonds, etc. 31, all different. Send P.O. value 4/-
WATSON, 85, Larkwood Road, Chingford, London E.4



Manage your own railway!

Any boy can boss his own railway if he has Hornby Trains. High-quality, long-running mechanisms, sturdy track and a variety of rolling stock and accessories, ensure maximum fun and interest. See the Hornby Passenger and Goods Sets now in stock at your local dealers.



*This is a Hornby M1
Passenger Train Set*

HORNBY TRAINS

MADE AND
GUARANTEED BY
MECCANO LTD.

THE MECCANO MAGAZINE

Build this fine model... and invent more!



The fascinating Meccano hobby becomes more and more fascinating as you add accessory outfits and spare parts, and are able to build still bigger and better models. Your local dealer can supply all your Meccano needs.

MECCANO

MADE IN ENGLAND BY MECCANO LTD.