

VOL. XXXIX No. 5

MAY 1954

MECCANO

MAGAZINE

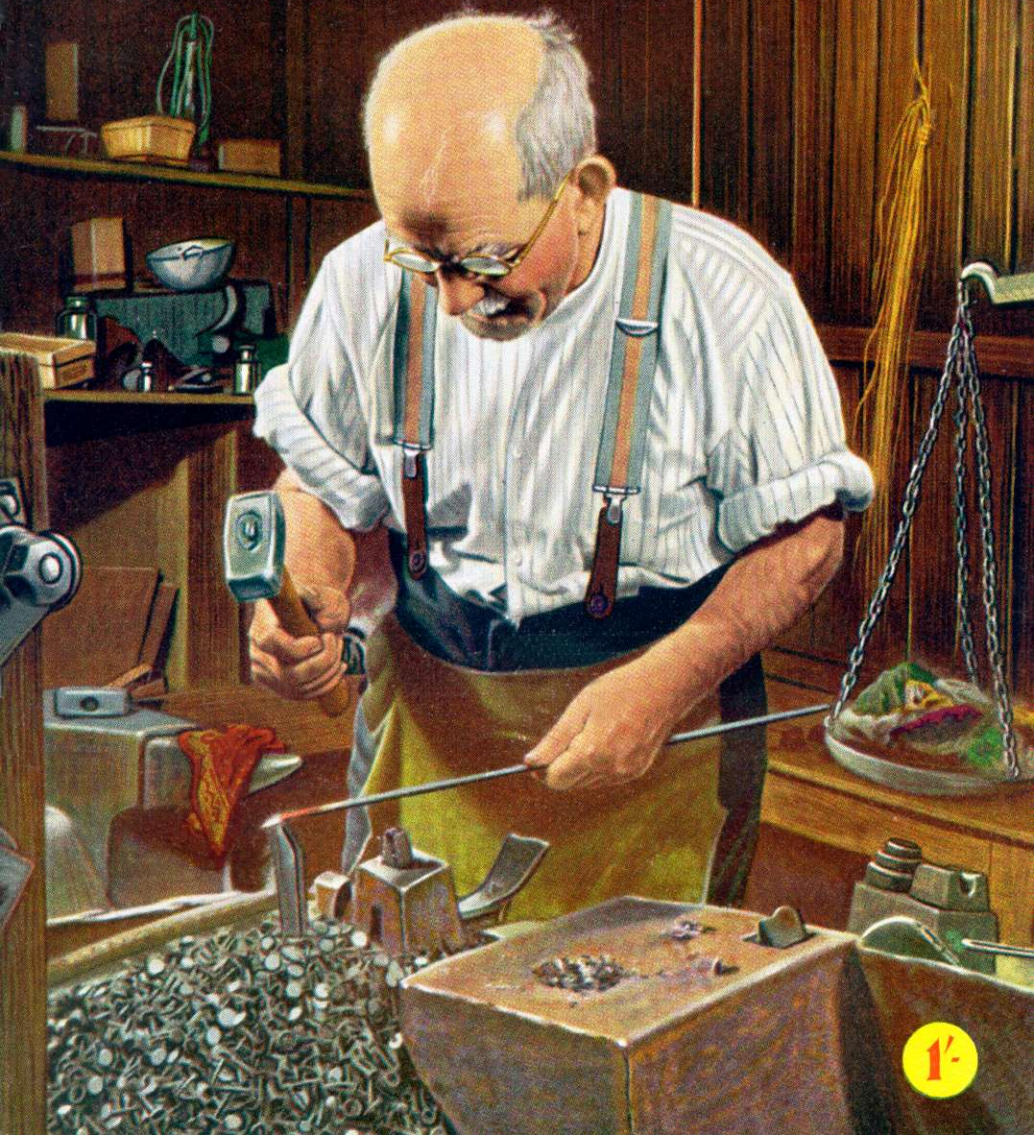

1/-

THE MECCANO MAGAZINE

DINKY TOYS

TRADE MARK REGD.

NEW**MODELS**
ready
during May**AUSTIN VAN "SHELL" No. 470**

The dependability and robustness of the popular Austin A40 Van are matched by this attractive Dinky Toys model. The miniature measures $3\frac{1}{2}$ in. overall, and is realistically coloured in bright green and red, with the name "Shell" in yellow on the nearside panel and 'B.P.' on the offside.

PRICE 2/11

See the
June
issue
for fuller
details
of these
models

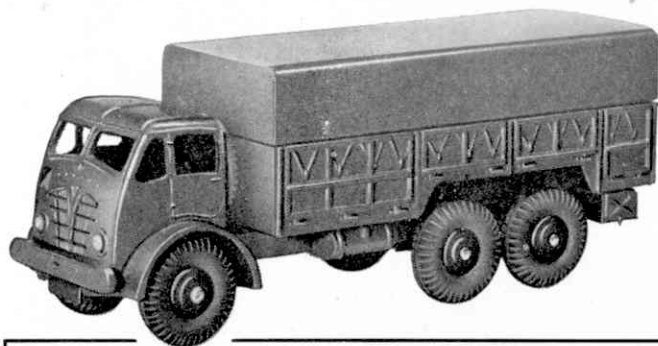
**10-TON ARMY TRUCK No. 622**

A fine companion model for the Dinky Toys Army Covered Wagon, Centurion Tank and Scout Car. Measuring $5\frac{1}{2}$ in. in length, this six-wheeled vehicle is fitted with detachable cover and the view on the right shows the interior seating for Army personnel. It is finished in service green.

PRICE 6/9



Prices
include
Purchase
Tax

MADE IN ENGLAND BY MECCANO LIMITED

DINKY TOYS

TRADE MARK REGD.

★ A re-introduction
in B.R. colours

All Prices include Purchase Tax

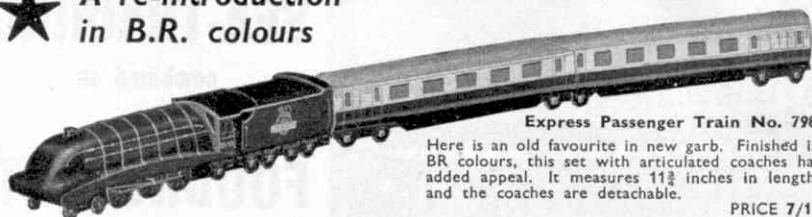

Express Passenger Train No. 798

Here is an old favourite in new garb. Finished in BR colours, this set with articulated coaches has added appeal. It measures 11 $\frac{3}{4}$ inches in length, and the coaches are detachable.

PRICE 7/10



No. 673
Scout Car
Length 2 $\frac{3}{8}$ in. 2/11



No. 651
Centurion Tank
Length 5 in. 7/11



No. 490 (30v)
Electric Dairy Van
Length 3 $\frac{3}{8}$ in. 3/4



No. 156 (140b)
Rover 75 Saloon
Length 4 in. 2/5



No. 172
Studebaker Landcruiser
Length 4 $\frac{1}{2}$ in. 2/8



No. 253 (30h)
Daimler Ambulance
Length 3 $\frac{3}{8}$ in. 2/11



No. 161 (40)
Austin Somerset Saloon
Length 3 $\frac{1}{2}$ in. 2/2



No. 623
Army Covered Wagon
Length 3 $\frac{3}{8}$ in. 3/7



No. 154 (40f)
Hillman Minx
Length 3 $\frac{1}{2}$ in. 2/2



No. 252 (25v)
Refuse Wagon
Length 4 $\frac{1}{2}$ in. 5/10



No. 157
Jaguar XK120 Coupé
Length 3 $\frac{3}{8}$ in. 2/8

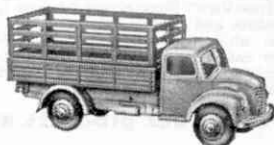

No. 343 (30n)
Farm Produce Wagon
Length 4 $\frac{1}{2}$ in. 3/6

MADE IN ENGLAND BY MECCANO LIMITED

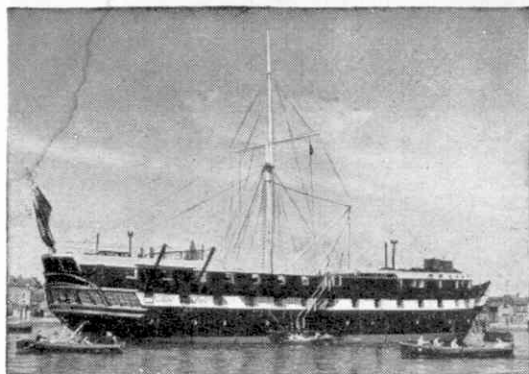

HOLIDAYS and SEA-TRAINING combined in T.S. FOUDROYANT

- * The FOUDROYANT is the only surviving sailing frigate of the Royal Navy.
- * She lies just inside the entrance to Portsmouth Harbour amid the hum and bustle of modern naval development.
- * The week's course includes the handling of boats under oar, sail and power; swimming; signalling and all things pertaining to life in a sailing ship.
- * Visits to modern warships and to the old Victory are arranged; and trips are made to Spithead, the Solent and the Isle of Wight in the ship's launch.
- * A memorable and valuable holiday, in an atmosphere where the past is linked to the present and the future. The charge in the holiday months of April, August and September is £3 15s. 0d. a week: at any other time £3.
- * Boys and girls are taken in separate weeks. Applications for bookings and other enquiries should be made to The Superintendent, T.S. Foudroyant, Gosport, Hants. (Tel. Gosport 88700).

3-D in your pocket!

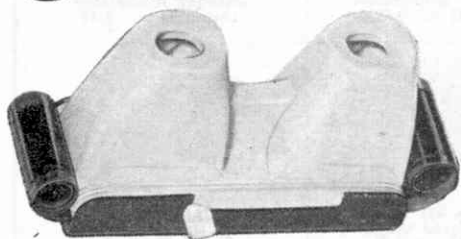

The amazing
"TRUE-VIEW"
Stereoscope
always ready for use!

You really do look "into" a picture used in the "True-View" Stereoscope, because it has astonishing realism and depth. Take one look and you'll want the whole series of fascinating film strips, which are easily inserted. Each film-strip consists of 14 separate scenes changed by means of the special self-aligning lever. There are 25 film strips

available, including London Scenes, English and Scottish Beauty Spots, South Bank Exhibition, Battersea Pleasure Gardens, Bertram Mills Circus, British Railways, London Airport, and The Zoo. Many others are in preparation. The "True-View" Stereoscope costs 18/6 complete with two film strips; extra film strips cost 2/6 each.

See all our products at good dealers. Write for illustrated list to

S.E.L.

(Signalling Equipment Ltd)

(Dept 3), MERIT HOUSE, POTTERS BAR, MIDDLESEX

PRIZEWINNERS OF THE
BRICKPLAYER COMPETITION
1954



1st PRIZE £21 0s. 0d.: R. SPRINGETT, 4 RECTORY LANE, MAIDSTONE, KENT.

2nd Prize, £10 10s. 0d.: D. Corke, 45 Hawkwood Crescent, Chingford, E.4.

3rd Prize, £5 5s. 0d.: K. Hall, College Farm, Harrowden, Beds.

CONSOLATION PRIZES

D. A. Shaw,
19 Bentinck Avenue,
Tollerton, Notts.

A. G. Standerwick,
7 Blumfield Crescent,
Slough, Bucks.

P. Howarth,
75 Stag Lane,
Edware.

Robert Howard,
68 Granchester Meadow, Newnham,
Cambridge.

A. Tilly,
56 Hiller Road,
Battersea, S.W.11.

G. Leeke,
8 Rockhampton Road,
South Croydon.

J. Collett,
3 Married Quarters, R.A.F., Dishforth,
Nr. Thirsk, Yorks.

A. D. Aldridge,
Windy Ridge, North Green Road,
Diss, Norfolk.

Entries for the next Brickplayer Competition must be submitted between 1st January and 28th February, 1955.

Brickplayer Kits at approximately 25/6 and 47/6 and extra accessories are available from good toysthops and departmental stores.

If your dealer cannot supply, write for address of nearest stockist to:

J. W. SPEAR & SONS LTD.
 (Dept. M), ENFIELD, MIDDX.

NEW!**EXPERIMENTAL OUTFITS****LEARN THE PRACTICAL WAY**

Whether you are a student for an examination; starting a new hobby; intent upon a career in industry; or running your own business — these Practical Courses are intended for YOU — and may be yours at very moderate cost.

EASY TERMS FROM £1 A MONTH

With these outfits, which you receive upon enrolment, you are given instructions which teach you in easy stages the basic principles of the subject concerned. A tutor is available to give individual help and guidance throughout the Course.

POST THIS COUPON TODAY

Please send me your FREE book on Practical Courses:

I am interested in.....

To: E.M.I. INSTITUTES, Dept. 197X, 43 Grove Park Road, Chiswick, London, W.4.

NAME

ADDRESS

IC.24

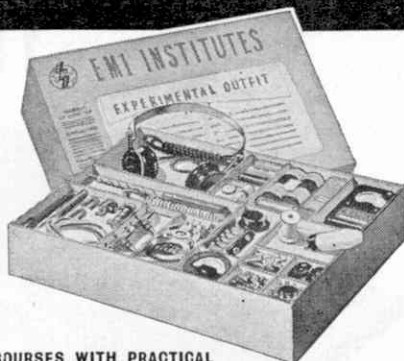

COURSES WITH PRACTICAL EQUIPMENT INCLUDE:— Radio (Elementary and Advanced), Television, Mechanics, Electricity, Chemistry, Photography, Carpentry. Also Draughtsmanship, Commercial Art, Amateur S.W. Radio, Languages, etc.

E.M.I. INSTITUTES

The only Postal College which is part of a world-wide Industrial organisation

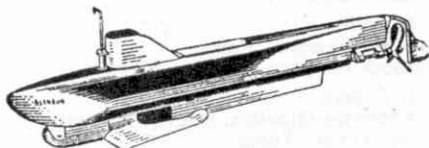
THE PRIDE OF THE FLEET!**'GLENBUR' MODEL SUBMARINES & TORPEDOES**

**FROM BRITAIN TO SINGAPORE
AND ALL POINTS EAST AND WEST
THE GLENBUR TORPEDO STRIKES!**

THIS SUPERB WATERCRAFT WITH A RANGE UP TO 30 FEET PRODUCES A REALISTIC EFFECT ON IMPACT WITH ITS TARGET, YET QUITE HARMLESS

SEND P.O. TO:—

GLEN-BURROUGHS & CO. LTD., FORMBY, LANCS., ENGLAND

MARK I SUBMARINE (Length 14 in.)
90 FEET OF DIVING PERFORMANCE

PRICE 21/6^D. (POST/PKG. 9d. EXTRA)

AND HER EQUALLY FAMOUS SISTER-SHIP

MARK II SUBMARINE (Length 7½ in.)
DIVING MORE THAN 30 FEET

PRICE 13/10^D. (POST/PKG. 6d. EXTRA)



PRICE 13/4^D. (POST/PKG. 6d. EXTRA)

What a marvellous bike!

No wonder Reg. Harris rides a RALEIGH!



Reg. Harris, World's Professional Sprint Champion three times in succession, knows what's what when it comes to cycles. Follow his example and choose a Raleigh.

Your friends will envy you its marvellous ease of

running, they'll admire its beautiful finish, and look up to you as someone who really knows about cycles.

It takes the world's largest and most modern cycle factory to build cycles of Raleigh quality. All the experience of craftsmen used to building cycles for champions goes into every Raleigh model.

So make up your mind now. Decide on Raleigh, it's 'the tops'!



Prices from £11.19.6 (Tax Paid)

Ask your dealer for a catalogue and full details of our special Easy Payments Scheme (deposit £2)

RALEIGH

NO CYCLE IS COMPLETE WITHOUT A STURMEY-ARCHER 3- or 4-SPEED GEAR AND DYNOHUB

A Product of Raleigh Industries Ltd., Nottingham

RC.185D

Build this Working Burrell Type Traction Engine



Write for "Model Shipping and Engineering Catalogue." A manual every model engineer will want to possess. Give the ref. MS.17.

Price 2/-

$\frac{3}{4}$ INCH SCALE

Length 14 $\frac{3}{4}$ "
Width 6 $\frac{1}{2}$ "
Height at chimney 8 $\frac{1}{2}$ "

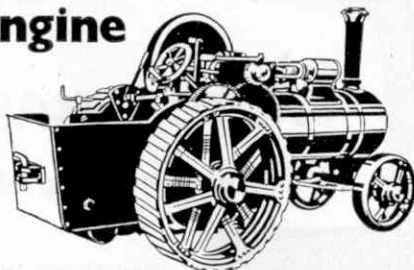

What could be more delightful to build than a Road Tractor? Yet even enthusiasts hesitate to tackle this type of model because of the intricacies in design and casting, especially of the road wheels. This set of castings is planned to give all the pleasure of construction without the more tedious work. The road wheels are single castings and need only machining and filing.

"How to Build a Traction Engine", a fully illustrated booklet on this model can be supplied on request. Price 1/-

BASSETT-LOWKE LTD.

Head Office and Works: **NORTHAMPTON**

LONDON: 112 High Holborn, W.C.1.

MANCHESTER: 28 Corporation Street.



56/- EACH

drive. Universal coupling. Ackermann-type steering. Floating rear bogie. Rubber tyres. Powerful Spring Drive. Comes ready assembled.

SCALE

MODEL LORRY

You can Dismantle it—Just like the real thing!

Made up from 65 standardised parts—all replaceable. Shaft

DYSON 8-TON TRAILER

Attaches to rear of the FODEN LORRY. And dismantles in the same manner. **17/6** EACH

★ ASK YOUR DEALER TO SHOW YOU THESE WONDERFUL MODELS!
ABBAY-CORINTHIAN GAMES COMPANY • LONDON S.W.1

SKYRO-COPTER

The High Flying, Far Flying
NEW Model Aircraft

PULL THE
CORD AND
UP
SHE GOES

2/9

Fully Tested
and
Delivered
to You

TWO FOR 5/-

STEPHENS OF STOCKBRIDGE
54 RAEBURN PLACE, EDINBURGH 4

Every Boy will be Flying this Summer Sensation

A.D.P. CHEMICALS & APPARATUS

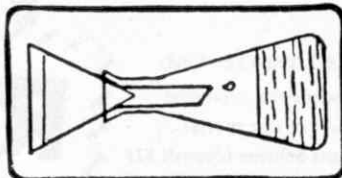

We can offer a large selection of equipment suitable for students & beginners, send stamp for list.

Special! Trial Package

COMPRISING APPARATUS & CHEMICALS SUITABLE FOR BEGINNERS. **PRICE 7/6.** Post & Packing 1/3.

14 (D/MM) SURREY ROAD, BARKING, ESSEX



AYE, AYE, CAP'N!
THEY'RE FAST—

THEY'RE Tri-ang
Regd. Trade Mark

Every old or young salt worthy of being sprayed by the ocean brine has one desire—to be captain of a fast sailing craft. That's just what Tri-ang yachts are—FAST!

We've seen 'em skim past at a rate of knots—and they're ocean going—we've tried 'em!

Start saving today, so that you may soon make yourself captain of a Tri-ang yacht. Get them interested at home—but make certain they know you want a Tri-ang yacht.

69/6

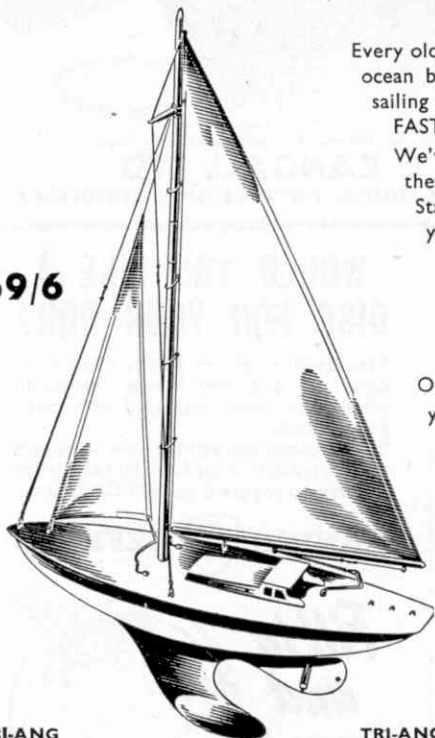

**TRI-ANG
C24 YACHT**

For all weather racing. Streamlined, all metal 24 inch hull; solid heavy keel; racing sails; improved rigging and automatic rudder control from main sheet. Brilliant two-colour finish.

Obtainable from
your local
stockist. We
do not
supply
direct.

14/11

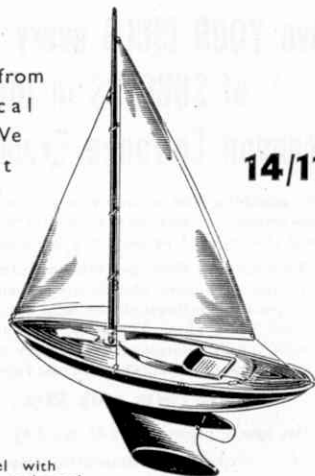

**TRI-ANG
C16 YACHT**

Bermuda rigged model with pressed metal hull and embossed "ocean racer" type deck. Simplified rigging and good quality white sails. Two-colour enamel finish.

PRODUCTS OF THE LINES BROS. GROUP OF COMPANIES



You can have super fun with this DAN DARE WALKIE-TALKIE

New! Wonderful! NO Batteries!

**Talk with your pals
at long range!**

Magnetically powered and using no batteries, the DAN DARE Walkie-Talkie is a thrilling yet simple application of a scientific principle and is ready for immediate use. It is supplied with 25 ft. of flex, but you can increase its range by adding as much flex as you like, even up to 1,000 yds.! For long distance communication indoors or out, the Dan Dare Walkie-Talkie, which is a 'Merit' Electronic Product, has great possibilities for really interesting games. Of all good dealers and stores.

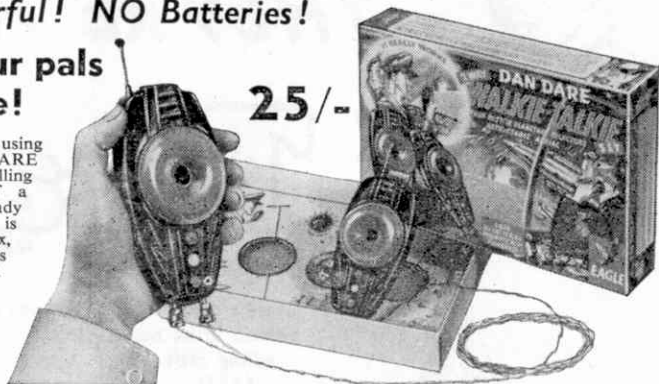

Send p.c. for particulars of other outstanding lines

J. & L. RANDALL LTD

(Dept 3), MERIT HOUSE, POTTERS BAR, MIDDLESEX

Give YOUR CHILD every chance of SUCCESS in the Common Entrance Examination

by coaching him at home in your spare time. All children are entitled to sit for this examination and thus gain a free place in a Grammar School. The Common Entrance Home Tutor Course for the 9-11 year old is comprehensive and complete and includes all the most suitable Text Books for English, Arithmetic and Intelligence work. It has invaluable advice and many, many hundreds of questions actually set in past Examinations.

It costs only 52/6

Also special courses for 5-11 and 7-11 year olds.

Write for fully descriptive folder.

COMMON ENTRANCE HOME TUTOR
Dept. (M2), 80 Wimpole St., London W.1

WOULD YOU LIKE A DISC FOR YOUR DOG?

Membership of the Lucky Dog Club costs 5/- only and brings chromium plated disc deeply engraved with name and address.

The subscription entitles new members to all privileges of the Club and also helps to carry on the good work of the League.

CANINE DEFENCE

*Fill in
and
send
with 5/-*

Dog's Name _____
Owner _____
Address _____
6/3/5

Mr. R. Harvey Johns, Secretary,
Canine Defence Lucky Dog Club
10 Seymour St., Portman Sq., London, W.1

Oh Boy BAYKO!

Bayko builds scores of beautiful models, including Railway Stations, Signal Boxes, Bridges, Houses, Public Buildings, etc.

PRICES

No. 0	Standard Set	14/-
No. 1	Standard Set	21/-
No. 2	Standard Set	33/-
No. 3	Standard Set	54/-
No. 4	Standard Set	104/6
No. 0X	Converting Set	7/-
No. 1X	Converting Set	12/3
No. 2X	Converting Set	21/-
No. 3X	Converting Set	50/6

OBTAINABLE FROM LEADING STORES AND TOY SPECIALISTS

Manufactured by PLIMPTON ENGINEERING CO. LTD., LIVERPOOL 3

ILFORD FILMS



for faces
& places

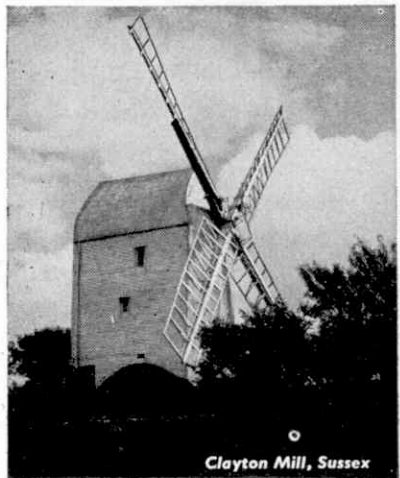

Clayton Mill, Sussex

ILFORD FILMS

FIT ALL POPULAR CAMERAS

FREE

A VALUABLE BOOK which details the wide range of Engineering and Commercial courses of modern training offered by E.M.I. Institutes—**OVER 150 CAREERS AND HOBBIES**

Courses including: Mechanical Engineering, Radio and Television, Automobile Engineering, Electrical Engineering, Civil Engineering and Building, Aeronautical Engineering,

NEW! Examination Courses for:—
 General Certificate of Education,
 B.Sc. (Eng.), Common Preliminary,
 and for A.M.I.Mech.E., A.M.I.C.E.,
 A.M.Brit.I.R.E., A.F.R.Ae.S., A.M.I.P.E.,
 A.M.I.M.I., A.M.I.H., & V.E., M.R.San.I.,
 A.M.I.E.D., A.M.S.E., L.I.O.B., City
 and Guilds Certificates, etc. Courses
 also provided for all branches of Com-
 merce and Business Management.

EXPERIMENTAL
 OUTFITS
 NOW
 AVAILABLE

COURSES
 FROM £1
 PER MONTH

— POST NOW —

E.M.I. INSTITUTES Send without obligation, the above FREE book, E.M.I. Institutes, Dept. 197K, 43, Grove Park Road, London, W.4.

The only Postal College which is part of a world-wide Industrial Organisation.

Subject(s)
 Name
 Address
 I.C.18HK.

A CAREER AT SEA

His training over at
**THE
 PRINCE OF WALES
 SEA TRAINING
 SCHOOL**

he begins life in the
 Deck Dept. of the
 Merchant Navy.

If your ambition is to be a sailor, an intensive training course of four months duration at one of the finest establishments of its kind in the United Kingdom will equip you with the knowledge and opportunity to fulfil that ambition.

Free training for sons of seamen

Enquiries from applicants between the ages of 15 years 8 months and 16 should be addressed:

General Secretary:

BRITISH SAILORS' SOCIETY
 680 Commercial Rd., London E.14. (Tel. East 4191)



- MARKLIN - TRIX

RIVAROSSİ - LIONEL -

THE CAB CONTROL MANUAL

Price 1/6

Tells you how to
run 2-3-4-5 or
more trains.



REGD. TRADE MARK

KIRDON MINOR

220/250 A.C. Input
12V. D.C. Output
with Controls.

Price 39/11

"The Complete Model Railway Catalogue"

140 Packed Pages

POST 2/6 FREE

220 Illustrations

An Absolute Essential for Model Railroaders.

MARKLIN DE LUXE 3-RAIL OR STUD 20-VOLT A.C.

Loco CM800 with Lights £2.16.3
4-wheel Coaches 5/11 each



Telephone ELGAR 3573 — or write to-day

TAYLOR & MCKENNA

98 CRAVEN PARK ROAD,
HARLESDEN, N.W.10

X-ACTO

ANORMA

WRENNIS

PECO

KIRDON

FARISH

C.C.W.

TRI-ANG

GAMAGES

Exceptional Bargain Offer!

'Miss EVER READY' ELECTRIC SPEED BOATS

USUALLY

27/-

SAVING
10/6

One of the
fastest Electric Model Speed Boats ever produced.
Designed on full size "Hard Chine" lines. Made from
aluminium. Finished in
brilliant red and cream, with
streamlined cabin. Length
11½ in. Post and Pkg. 1/1. Set of Batteries 1/6 extra.

GAMAGES
PRICE **16/6**

Gamages offer the NEW
HIGH FLYING, CUTTER TYPE

DAN DARE KITE

Length 31 in. Width 29 in.

Dan Dare design in Red,
Yellow and Black. Complete
with tail. Packed in a tubular
container with fully
illustrated instructions.

9/11

Post and Pkg. 9d.

Kite Cord and Winder 2/- extra.



GAMAGES, HOLBORN, LONDON E.C.1. HOL 8484

How to get your M.M. bound



Readers of the M.M.
can have their copies of
the 1953 issues bound in
the official cover by T.
L. Duncan Ltd., 20 Cum-
berland Street, Liverpool
1. This cover is in cloth
and morocco, and the
words "MECCANO
MAGAZINE" are
embossed in gold on the
back, with the year. The
cost is 11/6, including
return carriage.

Magazines to be bound
in this way should be sent,
carriage paid, to T. L.
Duncan Ltd., at the address
given, with a postal order
to cover the cost. (Please
do not send stamps or
cheques). Readers doing this
should say whether they wish the
coloured covers and the advertise-
ment pages to be included or not.

Volumes of the M.M. from 1942 to 1952
also can be bound in the official cover at the
same rate. The charge for those prior to
1942 is 16/6.

Develop YOUR Hornby Railway

How easy it is to convert a Hornby Clockwork Train Set into a fascinating railway by the addition, from time to time, of items from the wide range of Hornby track, rolling stock, and accessories.

See these Hornby components at your local Meccano dealers.

MADE AND GUARANTEED
BY
MECCANO LIMITED
LIVERPOOL

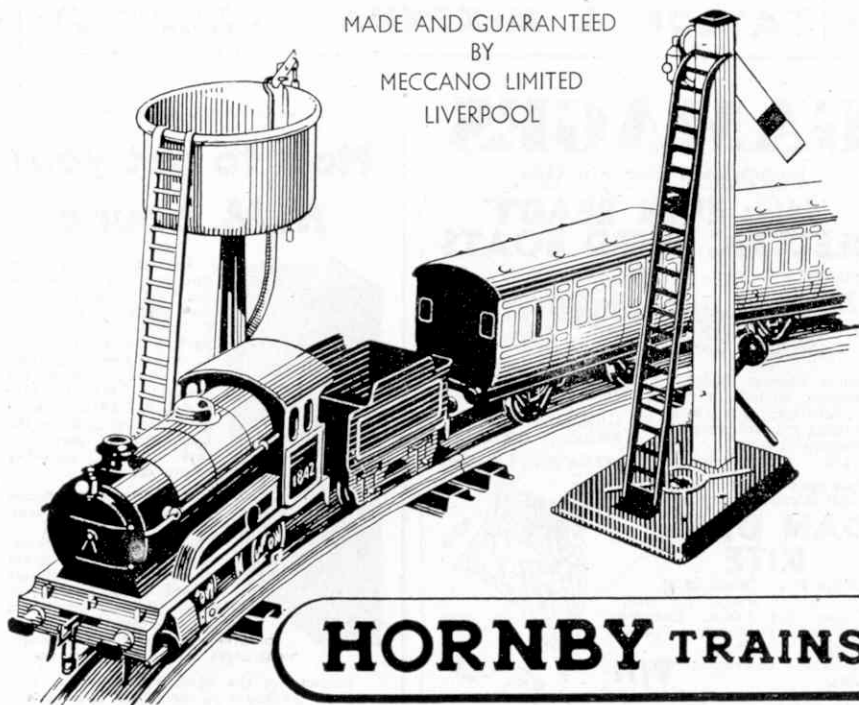

HORNBY TRAINS

Next Month: "THE NEW ZEALAND FERRY RUN."

MECCANO

MAGAZINE

Editorial Office:
Binns Road
Liverpool 13
England

Vol. XXXIX
No. 5
May 1954

Atomic War or Peace?

I remember many stories by H. G. Wells, written before the aeroplane became a familiar sight in the sky, in which he painted truly ghastly pictures of the havoc

Berlin! Wells must have had thoughts of radioactivity in his mind at the time, for his bombs did not merely crash down on the Earth to produce single gigantic destructive explosions. They were an "improved" variety that started some kind of festering disruption that continued to rage for weeks.

In these books the few who survived were pictured living in conditions of savagery. Since they were written we have seen air war of an intensity far beyond that described by Wells—and yet we have survived it, just as we have survived the introduction of gunpowder, the rifle and the gigantic guns of the last 50 years. Can we survive atomic warfare too, and why should we have to try?

These are questions that we must all ask. The time surely has come when every reasonable human being in the world should resolve to bring to an end the age-old fear of widespread battle, which in these times apparently would be waged over almost the whole area of the globe and would affect every one of us directly.

Fire and water can be destroying elements, but in the main we put them to good use. Coal is another source of power that we have harnessed to peaceful purposes. Why not do the same with atomic energy, which can solve so many of our problems? That would be a conquest worth making. It is now reported that some of the materials required, at present only used in perfecting the hydrogen bomb, are cheap and easy to make. So there is at least a possibility that we can generate atomic power without expending the astronomical sums that in the past have been so freely applied to the production of ever more fearsome destructive weapons.

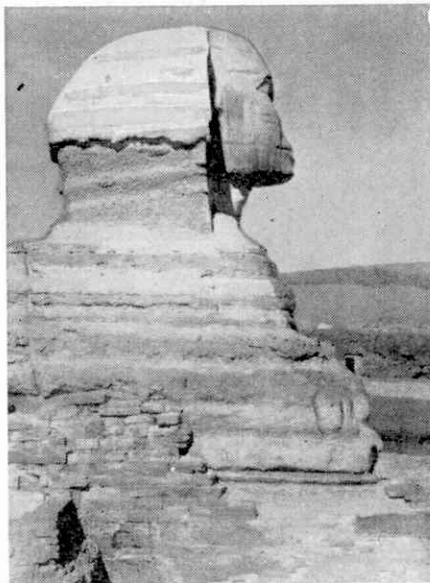

This fine picture of the Sphinx was taken by R. D. Stephen, Bournemouth. This wonderful relic of ancient Egypt was probably built about 2900 B.C.

that bombing from the air would cause. In one book he described an air raid on Paris that opened a war between Germany and France, and I still recall vividly the comment of the French Air Commandant when he heard of the raid. "*We will give them tit for tat, my boy,*" he said and immediately set off on a similar raid to

The Editor

Diesels on the Clyde

New B.R. Vessels for Scottish Waters

By W. A. C. Smith

IN January last British Railways made an innovation in the Clyde fleet by placing in service the vehicular ferry, *Arran*, the first of a class of three new ships. Lovers of the famous Clyde steamers had been somewhat prepared for this craft by the appearance the previous summer of the Maids, four passenger-carrying motor vessels of modest dimensions, which are very different in conception from the traditional paddle steamers and the later turbines. These, at first under private ownership and then operated lavishly by the rival railway companies, had developed the Clyde coast resorts with the world's finest co-ordinated rail and steamer service.

After nationalisation the famous vessel *Lucy Ashton* was disposed of, and in 1952 the veteran turbines *King Edward* and *Duchess of Argyll* were sold, the former for scrapping and the latter to the Admiralty for experimental work at Portland.

Meanwhile the British Railways £1,000,000 modernisation plan for the fleet had been revealed, and showed that the new vessels were to be diesel-driven ferries. The first phase provided for four small passenger vessels and the second for three larger mixed traffic types. As an interim measure, the small motor vessel *Countess of Breadalbane* was transferred by road from Loch Awe to the Clyde, but is now used for excursion work only.

The Maids, the new passenger vessels, are of 450 tons gross and have a length of 165 ft., a breadth of 28 ft. and a depth of 10 ft. Two sets of British Polar diesel

engines give a speed of 15 knots, and 650 passengers can be carried. The crew numbers 14. Tripod masts are fitted, the squat funnel is of aluminium and a special platform is provided at the forward end of the bridge deck to facilitate the embarkation and landing of passengers at any state of the tide. On the main deck is a tearoom and observation saloon—the latter with large windows and bus type seating—both comfortably decorated with curtains, light woodwork and rubber

flooring, but as on most motor vessels the noise and vibration from the engines is somewhat unpleasant.

The first of these vessels to go into service was the *Maid of Ashton*, which had been launched by Yarrow and Co. Ltd. at Scotstoun, Glasgow, on 17th February 1953. She took up the Gourrock-Holy Loch run on 25th May and was soon followed by her three sisters. The *Maid of Argyll* was built by A. and J. Inglis and Co. Ltd., Glasgow, and after entering service on 5th June she appeared on the services from Craigendoran.

Three weeks later she was followed from the same yard by the *Maid of Shelmorlie*. The final member of the quartet, the *Maid of Cumbrae*, built by the Ardrossan Dockyard Co. Ltd., made her debut on 16th July, and like the preceding vessel was mainly employed on cruises during the summer, but also acted as tender to liners calling at Greenock. These last two Maids have recently been on the winter services to the Holy Loch and Millport respectively.

A fortnight after the advent of the



P.S. "Duchess of Fife" at Gourrock.

Maid of Ashton, the last of the old timers, the fifty year old paddle steamer *Duchess of Fife* was withdrawn for breaking up. In addition the 1923-built turbine *Glen Lennox*, at present laid up, is unlikely to



The new motor vessel "Arran" at Gourock before entering service.

sail again, and the experimental diesel-electric paddler *Talisman* of 1935 is now kept in reserve.

The first of the new general purpose motor ships, the *Arran*, was launched on 22nd September last at Dumbarton by Wm. Denny and Bros. Ltd. She was specially designed for the conveyance of passengers, cargo, motor vehicles and livestock. Her dimensions are 185.6 ft. by 35 ft. by 7.6 ft. Her gross tonnage is 650, and she has a speed of 15.5 knots from twin screws driven by a pair of British Polar diesel engines. Electric power is provided by three diesel generators. Her passenger capacity is 450, with a crew of 21, and a lounge, tearoom and smokers room have been installed.

The main deck provides covered accommodation for cargo and up to fourteen cars, together with a bus. An electrically-operated lift raises or lowers vehicles between the pier and deck at all stages of the tide, while two turntables on the lifting platform facilitate stowage. Ramps are fitted at each side of the lift. In profile the most noticeable features of the vessel are the deep well for the lift and the high Samson posts aft. It has been stated that

she cost as much as the combined price of three turbine steamers and two paddlers built before the war.

The *Arran* commenced sailings on the Gourock to Dunoon service on 4th January last, and will be followed later this year on the Arran and Rothesay runs by the *Cowal* and *Bute*, at present under construction at Troon by the Ailsa Shipbuilding Co. Ltd. *Cowal* was launched on 20th January. These will doubtless prove useful vessels, as previously cars had to be loaded on the decks of the steamers or make a long detour by road.

The Loch Lomond service from Balloch to Ardlui, operated in summer only, has also received a new vessel.

This is the paddle steamer *Maid of the Loch*, which is a very handsome vessel, of conventional design, perhaps befitting a more imposing name. She was built in the Glasgow yard of A. and J. Inglis and Co. Ltd., and then, after each section had been numbered, was dismantled and transported by rail to Balloch, where re-assembly commenced in April 1952 on the slipway at the loch side. This method of construction was necessitated by her size, which prevented her being sailed up the River Leven to the loch. She entered the water about a year later and took up regular service on 25th May 1953.

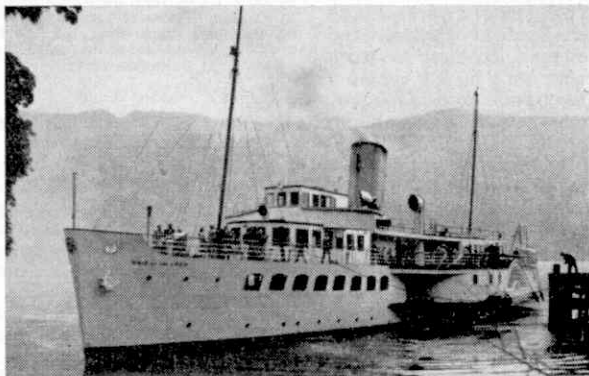

P.S. "Maid of the Loch" arriving at Ardlui on the 3.50 p.m. run from Balloch.

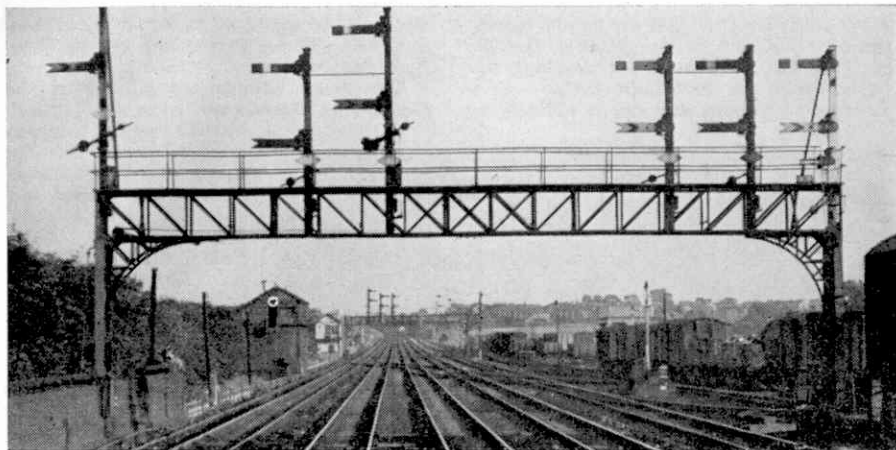

The Road to the South

By "North Western"

THE hospitality of footplate men toward their privileged guests is traditional, so when at noon one day I joined a pair of Bank Hall, Liverpool, enginemen, Driver A. Saunders and Fireman A. Callaghan, on the platform at Carlisle I was quickly made at home. They were there to take over the engine of the 10.30 a.m. from Glasgow Central, and by permission of British Railways I was to ride with them. They had worked outward from Liverpool, Exchange, the same morning, on the 9.43 a.m. and so all three of us were "working home" on the 1.22 departure.

Although on this turn the enginemen are changed at Carlisle, the engines themselves work through between Liverpool and Glasgow. So when our train came in we saw that our engine was to be No. 45698 *Mars*, a Bank Hall Jubilee and a sister engine to 45691 *Orion* of the same class, on which my footplate friends had worked north earlier.

We took over quickly from the Scottish Region enginemen, for the train was a little late and with several stops to make it was important to try and get back to right time.

We had a nine-coach train, including a 12-wheeled restaurant car, the tare weight totalling 295 tons, about 310 tons full. The water gauge showed a full glass when

we took over and pressure was comfortable at 200 lb. Once we were away, with the engine cutting off at 25 per cent. and the regulator opened to the first port, this rose steadily and was well maintained just under the blowing-off point of 225 lb. by the careful work of Fireman Callaghan.

The firing technique in the earlier part of the ascent to Shap was most interesting. Fireman Callaghan would put on a few rapid shovelfuls only at a time, close the firehole door and then a moment or two later, open it to repeat the performance,

resting on his shovel the while. In this way, and by careful management of the exhaust steam injector, he kept the boiler happy, although we were getting along up the more or less continuous ascent

through green and pleasant country past Southwaite. Just beyond this point a down freight came snaking towards us headed by a "Black Five" 4-6-0. This was only one of many down trains that we passed in the course of the run to Preston. There is little doubt that this West Coast Route is a busy one.

The line was steepening now, and Fireman Callaghan continued his skilful play of injector and shovel as we forged our way up. After the level stretch past Plumpton that the engine seemed to appreciate, a Patriot came buzzing down towards us on another fast freight.

The road to the South, photographed by W. S. Garth, from the Ribble Bridge at Preston. Trains to Liverpool travel on the third track from the left in order to diverge from the main line at Farington curve.

So we came to Penrith, our first stop, where after a brief halt we got away smartly, as there was still time to be made up. The Eamont Bridge marks a picturesque spot where the line crosses a well-wooded valley down below. Then soon we were launched on the 1 in 125 ascent past Clifton, where the regulator had to be opened wider and the note of our three-cylinder exhaust, with its rising-falling tone of six beats to the turn, became fiercer in consequence. Distant fells could be seen to our left and the next landmark was Thrimby Grange Box. Then came a stone-crushing plant looking as though it is on the left hand side ahead but which owing to the curving of the line is found actually to be on the right.

Steam was being well maintained over this length, but from 220 lb. or so it dropped to round about 200 over the final stage past Shap station. There was a little further to go on to the summit, 915 ft. above sea level, which we topped triumphantly on time as the result of the good work of the engine and her crew.

Now the regulator could be shut, and as the engine and train felt the effect of the 1 in 75 descent we really did accelerate in a thrilling manner, but a touch of the brakes now and again kept our gay progress within reasonable limits. The high quality

of the track work over this length was fully apparent from the footplate, both from the riding of the engine and visually. All too soon, with a warning hoot, we came to Tebay and almost immediately we were picking up water at Dillicar, just beyond, where the fellside is steep and there are

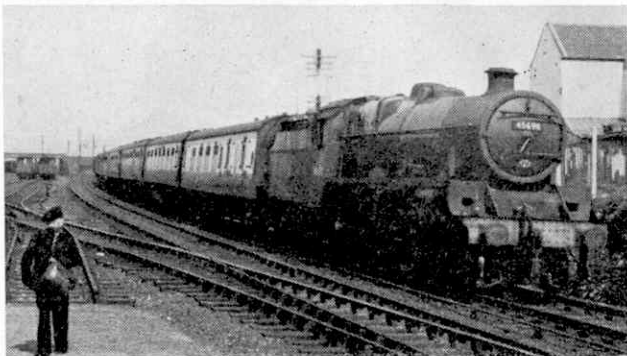

No. 45698 Mars running into Carnforth on the trip described in this article. Photograph by W. S. Garth.

red rocky patches projecting through the surface of the hills, great rounded close-shaven giants that hem in the line.

The order of our going was a little easier now, for a gentle rise succeeds the level stretch that extends for some distance beyond the troughs. Steam was on again, of course, and so we passed Low Gill, curving right and then left and up hill again now at 1 in 204 to Grayrigg. This station gives the ensuing bank its name. It provides a fine run down for southbound trains, but its 13 odd miles of climbing gives some hard work to the engines of

northbound trains before they come to tackle Shap itself. Again we skimmed downhill with regulator shut to the merry clatter of the motion, and with a gentle brake application now and again while northbound there toiled by us a heavy freight headed by another 4-6-0, with the assistance in the rear of a Fowler 2-6-4 tank. Their hearty exhausts as we coasted by provided ample evidence of the toughness of the climb and the weight of their train.

No sooner had we passed them, it seemed, than after



Driver A. Saunders of Bank Hall Motive Power Depot, Liverpool, views the road ahead from the footplate of No. 45698 Mars.

another curving stretch we were braking for the junction at Oxenholme. Here during the brief stop we took water, and the opportunity for a little conversation



An impressive view of the down Royal Scot climbing Grayrigg bank. The whole of the train of fifteen coaches is included in this picture, reproduced from a photograph by W. H. Foster, Bradford.

disclosed the fact that the exhaust injector had gone off song during the ascent to Shap Summit, but it had righted itself subsequently. We were quickly away from Oxenholme and soon after came the thrilling sight of Stanier Pacific No. 46222 *Queen Mary*, then still painted blue, bustling north with a Birmingham-Glasgow express. I had seen the same engine at Carlisle on the up *Postal* the previous evening and had wondered then what her return working would be.

After Hincaster Junction came another Stanier 4-6-2, this time on the down *Royal Scot*. Here the line opens out more and after passing another down train, a freight whose smoking engine was evidently being heavily fired for the climb ahead, with the brakes on again we came cruising into Carnforth station where my good friend Mr. W. S. Garth, whose pictures you have often seen in the *M.M.*, had arranged to be at the platform end with his camera at the ready.

We arrived at Carnforth as scheduled and left promptly, making good progress over the easy stretch that follows, where at Hest Bank is the only place on the West Coast Route where the line is really near the coast. Our tender tank was filled at the troughs here and shortly Lancaster Castle came into view and we were

alongside the platform of Castle station.

After bright weather from Carlisle over the fells we now had an overcast and dull sky as the easy grades toward Preston succeeded the steep climb up out of Lancaster. Very soon, it seemed we were picking up water again, at Brock Troughs where is the bridge well known locally as Badger Bridge, as it carries the badger crest of the Brock family. After Preston our route left the West Coast main line at Farington and we headed across the level country of West Lancashire on the last leg of the journey. The timing over this stretch is generous, possibly in order to allow some margin for recovery in the event of the train being delayed further North.

The work was easy here because we were well up to time and the engine ambled cheerfully along until the stop at Ormskirck.

Here we came into the electrified area with rather more intensive signalling than on the open stretches of main line. Several checks followed and on two occasions we had almost stopped when the offending signals were cleared. It was a case of steam off, brakes on, brakes off, steam on, several times over until we did actually stop at the gantry by Aintree (C.L.C.) Junction. Here as we came to a stand Fireman Callaghan dropped off in order to go to the fireman's call box installed by the gantry in order to notify the signalman that we were waiting. Just as he got to it the signal cleared and after further progress of this kind we took the fast road at Walton Junction to join the old Lancashire and Yorkshire main line from Manchester (Victoria). We made better progress now through the two Kirkdale tunnels and as we came past the home depot for engine and crew at Bank Hall, the fireman's call of *one off, Stanley Road*, brought us to a local point that I knew. We encountered one yellow and then a double yellow warning signal, but a welcome green aspect gave us the road into Liverpool Exchange where we pulled up dead on time at 4.46 p.m., a nicely judged piece of running.

Hand-Made Nails

By W. K. V. Gale

THE making of nails by hand was a very old craft. References to nails made in Staffordshire, which eventually became the great centre of the trade, were made as early as the reign of King John, from 1199 to 1216. The trade was always domestic in character, the work being carried on in little workshops attached to the nailers' dwelling houses.

Over a long period nailing expanded, and from about 1750 onwards, when improved iron-making techniques made available increased quantities of iron rods suitable for nail making, the expansion was considerable. By about 1830 indeed, no less than 50,000 workers were engaged in nailing in south Staffordshire and north Worcestershire. The trade had then reached its peak.

Machine-made nails had been

The interior of a nail shop. The hearth, on the right, and the treadle hammer, on the left, can be seen clearly.



introduced some years earlier, and the machine competed with the hand worker with increasing success from that time onward. The result was a steady decline in the number of nailers at work. By 1900 only about 4,300 nailers remained, and in the last fifty years the trade has become virtually extinct. A few nailers were still to be found in Worcestershire in 1951, and two of these survivors of a once-great trade are shown at work on our cover and in the illustration on this page. Mr. Albert Crane, on our cover, has since died, and Mr. Frank Weaver, seen above, has retired.

Like many other old trades, nail making had its own customs, some of them unique. Nailing was essentially a family enterprise, even the children being put to work as soon as they were big enough to be of use.

Starting at a very early age, the nailer soon developed a high degree of skill, and it is of interest to note that a careful study of a nailer at work in 1951 showed that there was no possible means of improving his technique. By long practice he had become so fast and skilful at his work that only the machine could beat him.

The nailer's equipment was simple. He had a hand hammer, a small anvil, a "bore" or hollow tool in which the partly-finished nail was placed to have its head formed, and a treadle-hammer for heading. The iron rods were heated in a small hearth similar to that used by a blacksmith, but much smaller. Some idea of the skill developed by long practice can be gained

from the fact that the nailer shown on our cover made two brush nails, which are like large tacks, every six seconds. They were surprisingly uniform in size and shape, the more so as the nailer had no means of measuring, and judged the amount of iron on which he worked solely by eye.

The business of marketing the nails was very complex. It was undertaken by a nail master, who supplied the iron to the nailer, and bought his finished nails. The basis of trading was the "tale," or thousand nails but this was purely nominal, since the nailer had to deliver to the master 1,200 nails for every nominal thousand, while the master, in selling, used a count of either 960 or 750 per thousand.

A Flying Radar Station



by John W. R. Taylor

ALL radio, radar and television waves travel in straight lines. But, as most of you will know, we can pick up on our radio sets programmes from as far away as America or Australia, despite the curvature of the earth, because radio waves are reflected back to earth by belts of electrified air called the Heaviside and Appleton Layers, which are about 70 and 140 miles respectively above the earth's surface.

Unfortunately, television and radar waves do not "bounce" off these Layers like radio waves but pass through them. As a result, we cannot receive television pictures if we are far from a transmitter, and radar will not detect aircraft more than a certain distance from a radar station. In each case, the curvature of the earth gets in the way.

The diagram on the opposite page makes this easier to understand. You can see that the lower limit of the beam sent out by the ship's radar set is decided by the earth's curvature. Enemy bombers flying low over the sea cannot, therefore, be picked up by the ship's radar until they are very near—perhaps so near that it is impossible to launch fighters in time to intercept them.

The same problem applies to shore-based radar stations, which is why German tip-and-run raiders used to fly in low over the Channel, beneath our radar screen, during the war.

The taller a radar transmitting aerial can be made, the further it is able to "see" before the earth's curvature gets in the way just as, at the seaside, you can see ships from the top of a cliff that are below

the horizon when you are on the beach. So, radar and television aerials are always made as tall as possible. But obviously, there must be a limit to their height, and this is particularly serious for a naval force, because there are no little bands of Royal Observer Corps "spotters" in rowboats in mid-ocean to fill the gap when radar fails.

Fortunately, United States Navy experts found the answer some years ago with a radar aerial more than 20,000 ft. high—not a wireless mast four miles tall, of course, but a "flying radar station" cruising at that height. As shown in the diagram, such aircraft, in radio contact with the ships, can give warning of approaching enemy bombers long before the ships' own radar detects them. They are, consequently, called Early Warning aircraft.

One of the first U.S. Navy 'planes to be equipped with early warning radar was the versatile Douglas Skyraider; and a number of these AD-4W Skyraiders were supplied to our own Royal Navy a couple of years ago. They can be identified by the enormous plastic radome under their fuselage, which houses the rotating radar transmitter or "scanner."

The AD-4W extends considerably the range of a ship's radar "eyes"; but, obviously, the bigger the aircraft the more powerful the radar equipment it can carry. So the U.S. Navy began looking for a larger early warning machine and, preferably, one that could cruise for long periods at high altitudes. They soon found the answer in the Constellation air liner; and Lockheed were given a contract to

Shown above is the first flight photograph of the new United States Air Force RC-121C "Super Constellation" type radar aircraft. The illustrations to this article are reproduced by courtesy of the Lockheed Aircraft Corporation, U.S.A.

produce two Constellation WV-1 "flying radar stations."

By the time they had finished, the normally beautiful, streamlined "Connie" was almost unrecognisable. Height-finding radar was housed in an enormous 8 ft. high hump on its back; another scanner rotated in a gigantic radome under its fuselage. More equipment filled its "thimble" nose and bristled as knobs, spines and aerials all over its sleek skin.

Despite which, the designers did their job so well that the aircraft's performance and manoeuvrability were hardly affected.

The two WV-1 Constellations were used for three years to test and develop aerial radar search techniques. Meanwhile, Lockheed had produced the new Model 1049 Super Constellation, with 18½ ft. longer fuselage and even better performance. Four 3,250 h.p. Wright Turbo-Cyclone engines gave it a cruising speed of 335 m.p.h., and its already good range of around 4,000 miles could be increased by fitting wingtip tanks.

It was just what the Navy wanted; so they gave Lockheed a big contract for WV-2 Super Constellation early warning

aircraft, and the U.S.A.F. followed up with orders for basically-similar RC-121C "Super Connies" to extend the range of America's frontier radar defences, particularly in Alaska and the Arctic.

Chief use of the Navy's WV-2s will be to fly from land bases to points far at sea, where they can patrol for long periods, guarding naval task forces from surprise attack.

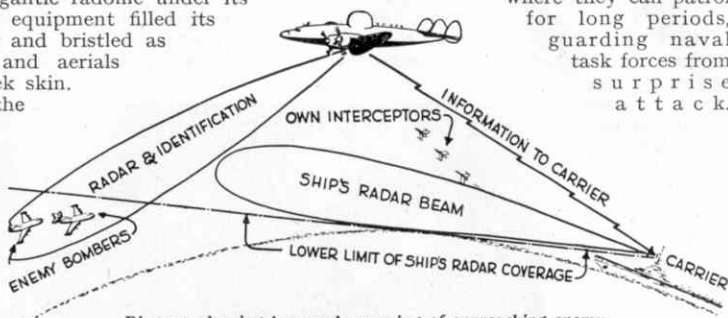

Diagram showing how early warning of approaching enemy aircraft can be given by the radar equipment carried aloft by the U.S. Navy's WV-2 "Super Constellation" and the U.S.A.F.'s basically similar RC-121C.

But they are also equipped to guide carrier-based fighters and strike aircraft to enemy ships, far beyond the range of the task force's own radar search equipment; and their radar will detect oncoming storms.

To perform these duties, they carry a crew of up to 31 men in sound-proofed cabins, with special seats that are scientifically designed to minimise fatigue on long missions. The cabins are pressurised to maintain 10,600 ft. comfort at 25,000 ft., and are air conditioned to give a temperature of 75 degrees even when it is 60 below zero outside.

A fully equipped galley, bunks for off-duty crews, and a complete electronics maintenance workshop for in-flight adjustment and repair of the aircraft's six tons of electronic equipment complete what is not only a powerful addition to America's air defences but probably the most comfortable warplane in the world.

For those who like figures, the Lockheed WV-2 has a wing span of 123 ft. and length of 115 ft. Its top speed is 350 m.p.h. and it weighs over 130,000 lb.



Ground view of the RC-121C. The 8ft. high hump on the back, the huge bulge underneath and the elongated nose house radar antennae.

Millions of Them!

How Meccano Bolts are Made

I WONDER how many million Meccano bolts and nuts have been made since Meccano first came to light. For that matter I wonder how many are made in a year now. The number of course runs into millions, and they are to be found everywhere. What indeed would life today be without them? There would be no Meccano

Looking into the heart of one of the machines on which Meccano bolts are made.

models for one thing, and that would be a real catastrophe. Then fathers and uncles would never make a beeline for their sons'

Meccano Outfits when they want a bolt and nut in a hurry to do some little repair in the home or in the garden shed; and even mothers would be disappointed, I am sure, if no Meccano bolts and nuts rattled into their vacuum cleaners, if only because that would deprive them of the opportunity of drilling into their offspring the importance of keeping everything in its proper place!

Bolts and nuts are interesting enough from this point of view, but they are even more interesting as engineering products. Making a bolt may not be quite the same as building up a giant machine such as the Craven boring and

milling machine described and illustrated in last month's *M.M.* But the same care and precision have to be taken in producing it, for after all the failure of a bolt could easily mean the collapse of an entire

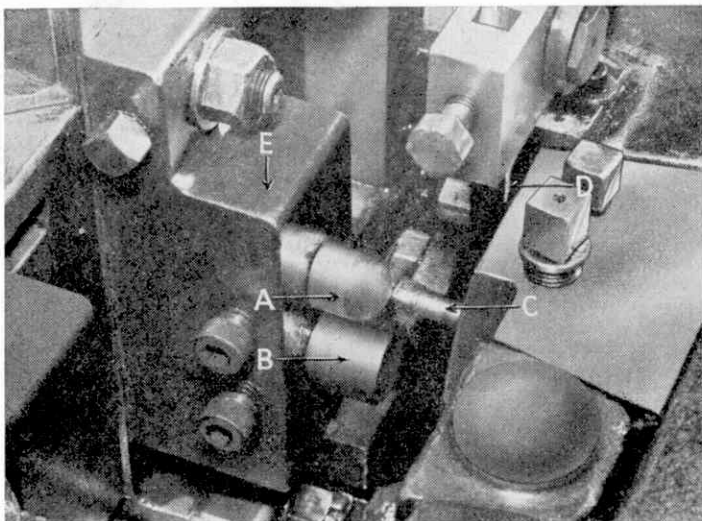

Meccano model, which must never happen!

Let us have a look at the making of a bolt. Obviously the best way to begin is to cut a mild steel rod of the required diameter into lengths. The novice might think that this rod should be of the diameter of the bolt head, and that part of the metal should be tooled away on a lathe to leave the proper shape. This would be wasteful and it is unnecessary. The rod used in practice has a diameter slightly smaller than that of the shank of the bolt, not the head.

How then is the head formed? To answer this question look at the larger picture on this page. In it you are looking down

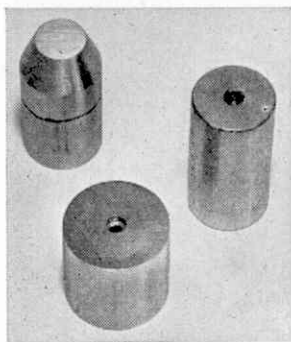

Above are the two tools, successive blows from which form the head of a Meccano bolt. Below them is the die in which the head is formed.

Rolling the thread on a Meccano bolt.

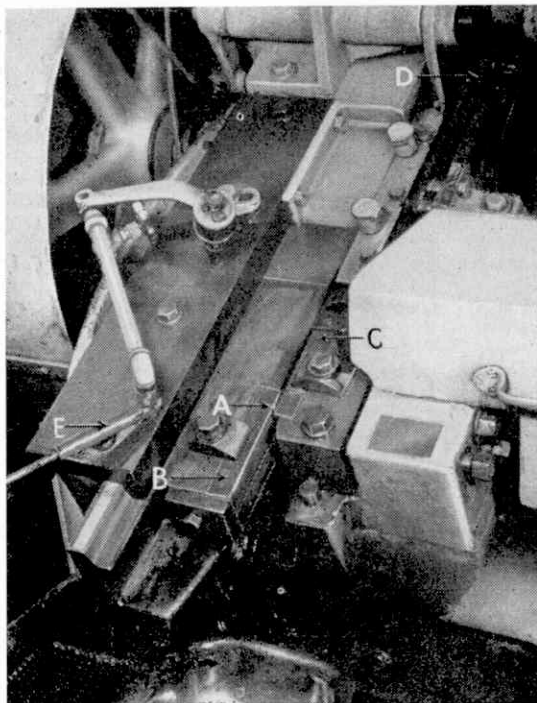

provide the place in which the metal for the head is shaped. This is done by two violent blows, one by the tool shown on the right, which has a recess in its face and the other by the tool seen on the left, which has a plain face. The first blow squeezes the end of the rod into a pear-shaped head, and the second flattens this out to fill the die completely, and thus give the head the right shape. Forming the head in two stages instead of in one gives a better flow of metal under the pressure applied, and therefore a stronger bolt head.

The tools are mounted one above the other in the tool head marked E in the picture of the machine. This moves backward and forward, and at each forward stroke alternatively up and down, so that first the recessed tool A and next the flat tool B strike the rod to form the head, after which the bolt is ejected, to drop into a collecting tray.

The bolt made in this way still needs threading and of course has no slot for the screwdriver. The slot is cut first, on a machine that is fed automatically with the blank bolts, which pass in turn under a circular cutter that is rotating very rapidly and forms the slot in very short time. From this second machine the bolts in the making then move on to a third for threading. The thread is actually rolled on, each bolt in turn being rolled between two hard steel dies, with grooves on them that correspond to the exact profile of the thread, to shape the metal of the shank of the bolt into the required form.

The thread rolling machine is
(Continued on page 260)

on the tools that perform the apparent miracle of making the bolt head. The coil of wire from which the bolt is made is passed through an opening on the right of the machine, to emerge below the blade marked D. As it is pushed forward its end comes up against the stop C—the place where this happens is just invisible in the photograph—and D then slides forward to cut off the length of rod required, which is seized by fingers and carried across the face of the machine, to be held in a position opposite to the die in which the head is to be formed.

You can see what the die is like if you look at the lowest of the three tools shown in the lower illustration on the previous page. There is a hole through the centre of the die, and this hole is counterbored at the end to

Dies used in
threading a
Meccano bolt.

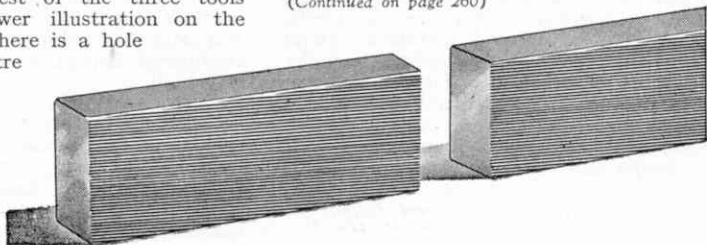

A Fine Locomotive History

By the Editor

THE North Eastern Railway was one of the greatest of the pre-group railway systems of Britain and maintained a well-preserved monopoly between the Humber and the Tyne. It was a product of amalgamation—almost 100 years ago now—but it had its roots in the earliest mineral railways in the North East, whence sprang the first real railwaymen. It was primarily a line of heavy freights, and this naturally had its effect on the locomotive stock, so that its freight engines were numerous and long lived, many of them being still in service, more than 30 years after the railway company itself ceased to exist. It was also the central partner in the East Coast Route to Scotland and provided haulage for the Anglo-Scottish trains over part of their journey. So it was no mere provincial line, although it did not come to London. It was important in its own right and prospered in serving its district well.

In its early days, as with most railways built up by amalgamation, the engines of the N.E.R. were a diverse lot. Just how diverse I had not fully realised until I read Mr. Nock's delightful and well illustrated story of them*, which includes accounts of many runs logged by the author and others, as well as full accounts of the locomotives.

For a long time last century there were four spheres of N.E.R. locomotive influence, which had their separate beginnings in the original constituent companies. So Leeds, York, Darlington and Gateshead shops had a large measure of independence under the general supervision of Edward Fletcher, the Locomotive Superintendent, not only in such external details as painting—although all engines were green—but also in design and appearance.

After this came more uniform progress, but this was preceded by a stormy spell under the chieftainship of Alexander McDonnell that heralded a change from the old methods to the new. With Thomas Worsdell came the institution of a general locomotive style that persisted to the end of the North Eastern era. His reign and that of his brother Wilson, who succeeded him, covered the years from 1885 to 1910, and this period saw the introduction of the Worsdell-von Borries two-cylinder compound system and the development of

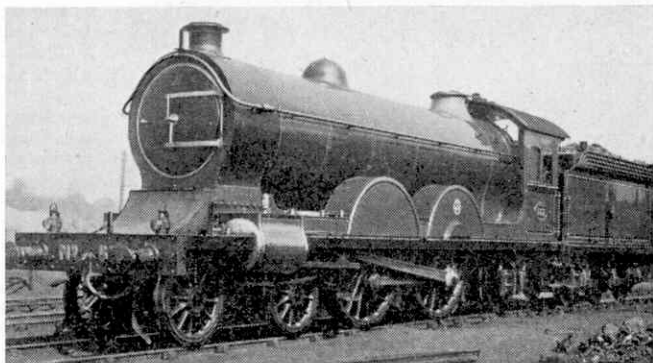

North Eastern Atlantic No. 532, the first of its class, introduced in 1903 during the Worsdell regime. In ironic reference to its size, for those days, this engine was known as the "Gateshead Infant". Photograph by W. J. Reynolds.

the first Smith compound. W. M. Smith, the originator of the latter, was Chief Draughtsman in the locomotive department of the N.E.R. for years, and was a powerful figure behind the scenes, as it were, until his death in 1906.

Wheel arrangements had progressed to large 4-6-0s and stately Atlantics as early as 1903. Just before the end of the Worsdell period there was a reversion to the 4-4-0 in the 10 big engines of the R1 class, surely in their bright green uniform and brass trappings the most impressive 4-4-0s of the traditional British inside-cylinder design ever built.

In the succeeding regime of Vincent Raven came the adoption of three-cylinder simple propulsion and superheating, both features being incorporated in the beautiful and dignified Z class Atlantics that sufficed as the premier North Eastern express engines until L.N.E.R. days.

*"Locomotives of the North Eastern Railway" by O. S. Nock. Published by Ian Allan Ltd., price 25/-.

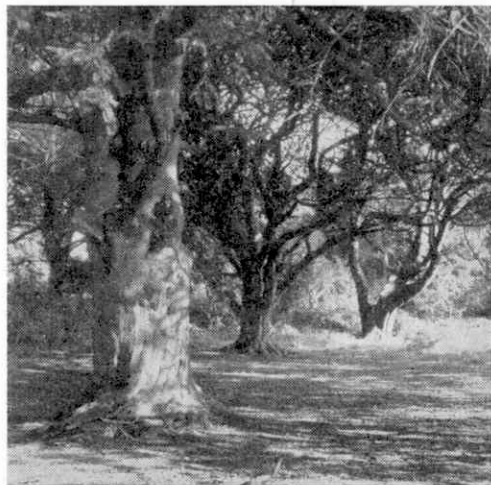

Kingley Vale

By Garth Christian

which slowly but surely dominates the competing species and gradually denies the ground beneath more than a small ration of sunlight. The "acid cap" which forms on the surface soil carries an interesting if impoverished plant life that includes a number of heaths.

There is room for endless disagreement on the age of trees, and not every expert would accept the claim that some of the yews of Kingley Vale are 2,000 years old. What is certain is that the wood was not a great deal different when the first Queen Elizabeth reigned; many of the huge trunks we see today were growing when William the Conqueror left the shores of Normandy 900 years ago; and the character of the place has not changed a lot since prehistoric men walked these Downs.

Few birds favour the gloom of the yew wood, nor is it likely to become fashionable with holiday-makers. There lies much of the charm of Kingley Vale. Like the previous owners, the Nature Conservancy grant public access to the wood as long as no damage is done.

The Nature Conservancy was granted a Royal Charter in 1949, and is managed by the Privy Council and financed by state funds. Its aims

include the preservation of animal and plant life, and the stimulation and conduct of research into the highly complicated problems of conservation. In its short life, the Nature Conservancy has already studied the problems likely to arise from the small-scale introduction of reindeer into Scotland, problems of coast erosion, comparative rates of tree growth, and the effects of the spraying of roadside verges with herbicides. A number of research stations have been opened, and many more nature reserves are likely to be established before long.

Before the end of 1953, eleven nature reserves were established, ranging from the Moor House reserve of 10,000 acres among the hills of Westmorland—some of them 2,700 feet high—to the fens of East Anglia. Though many of these reserves are vast in comparison with Kingley Vale, none is more remarkable in its way.

NO visitor to Kingley Vale, four miles north of Chichester in Sussex, can doubt the wisdom of the Nature Conservancy in declaring the area a Nature Reserve. Where else can one see so many stout and gnarled yew trees, some of them more than 1,000 years old, shutting out the sunlight and transforming a few hundred acres of Downland into a place of mystery and strange, solemn beauty?

Scientists from many European countries have visited this unique comb on the southern slopes of the South Downs, near to the villages of Singleton and Chilgrove. It is best approached on foot—or in a Land-Rover—for the rough tracks of the neighbourhood were not made for modern cars. Yet those with the energy to tackle the long walk from Chilgrove are not likely to be disappointed. The area, known in less genteel times as Kingly Bottom, is Britain's finest example of a natural yew wood on chalk, with its unusual plant community.

If neither sheep and cattle nor rabbits grazed upon the South Downs, stretching from Beachy Head and Eastbourne to the Hampshire border, the smooth green turf would rapidly revert to scrub and woodland. This has already happened in places. As higher costs have made sheep-farming less profitable, neglected Downland turf has been invaded by juniper and hawthorn, ash and beech. Around Kingley Vale, the invader is yew,

Each century the holes of the old yews of Kingley Vale thicken a little. Some of the trees are more than a thousand years old.

On the Road

By J. Dewar McIntock

IN the motor cycling world, this month marks a transition stage in two senses. In the sporting field, the picture changes from the sombre hues and chilly but cheerful atmosphere of the reliability trials to the colourful scene and hotter pace associated with road and grass track racing, hill climbs and so on. For the less sporting motor cyclist or the out-and-out tourist, of course, it is a case of shedding some of the "Arctic" clothing, and getting to far away places in warm sunshine, with the smell of hot tar in his nostrils, mingled with those of petrol, warm oil and the scents from the fields . . . always with the reservation that the English climate *may* be in one of its awkward moods!

The big Silverstone Motor Cycling meeting has, of course, taken place before this appears in print, no doubt with the usual polished success. But the road racing calendar is really only getting into full swing, and we shall watch with the greatest interest our representatives fighting the foreign and transatlantic challengers. As in the car field, one finds English "champs" on foreign machines, of course, but that simply makes things more interesting, and may well be of great value to our own manufacturers, as they can study the rival machines. Conversely, there will be European, Commonwealth and transatlantic riders on British machines, so it is all very matey and international.

Our riders and machines have been doing well in most fields already this year, showing up the car folk a little! It was very gratifying to learn that in the American 200-mile National Championship meeting at Daytona the first four places were taken by B.S.A. machines. The winner was Bobby Hill, from Ohio. In a 50-mile event on the same occasion, Bob Stilwell, a Texan "hombre", took first place from two Harley-Davidsons, with his Triumph Tiger. In the car world, however, our old friend Stirling Moss did score a notable

triumph in the Sebring Race, in Florida, which has been described as the American Le Mans, but this was in an Italian car, the Osca, with the American Bill Lloyd as co-driver.

There is great excitement in the car world, of course, with all these new Grand Prix motors showing their paces, if only on the continent so far. I get the impression that competition is not likely to get really hot and fearsome until the 12-hour race at Rheims, at the beginning of July, and that may be the occasion, according to my friend Grand Vitesse of

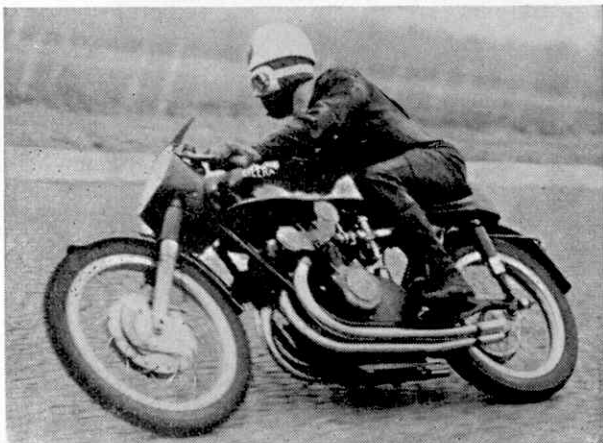

Geoffrey Duke tries out the new four-cylinder 500 c.c. Gilera at Monza.

The Motor, upon which the latest Grand Prix Lancia, a V-8 twin-cam, looking like a B.R.M. but with big slab tanks at sides, may well show its mettle. The remarkable streamlined Mercedes may be there too.

As usual, I have been out and about in the industry quite a lot. I paid an interesting visit to Wellworthys, who are so famous for their pistons and rings. What interested me most was a technique they have developed for bonding aluminium or its alloys to steel, iron, etc. A typical example was a motor cycle cylinder barrel. This was a great, husky, deeply-finned affair. It was almost all aluminium, the exception being the simple steel sleeve that made the actual bore. Perhaps "sleeve" is not the best word, because the aluminium really becomes a part of the steel, at the junction



Wellworthy Al-fin cylinder barrels being machined.

Those lads get a fine training, and have the very best of equipment, and there does not appear to be too much emphasis on the military aspect of the thing. Excellent discipline and good leadership training, but no humbug, if you know what I mean.

There are three of these schools—at Arborfield, Harrogate, and Chepstow. They turn out highly-skilled young engineers in three years. Mind you, of course, this is intended solely for those fellows who want to make the Army their career, as well as being engineers, but the thing is that these schools give them a wonderful chance of being N.C.O.s at an early age.

of the two. This technique involves casting the lighter metal on to the steel, but there is a heavily-patented method of doing it.

Then I had great fun when I drove the new Leyland two-pedal control chassis up to the Lass of Richmond Hill. It was a real joy to move a little lever through a miniature gate, and get a clean gear-change without any footwork at all. You may have seen this demonstrated on television, by the way. I wasn't fortunate enough to have any glamorous commentators with me, however . . .!

I did mention this system very briefly in my last contribution, but I should like to add that it consists basically of a normal epicyclic gear-box and fluid flywheel. Instead of the driver having to pre-select the gears and then use a pedal, there is air-pressure assistance to the epicyclic mechanism, and the small lever already mentioned simply directs the air to the appropriate brake-band of the gear-box. The only force the driver need apply is, literally, that of one finger.

Will this be adapted for car use? Perhaps, in the course of a few years, but it must be remembered that cars do not have air equipment, while many buses and lorries have it for the brakes. However, Armstrong-Siddeleys are using something similar, and we may see luxury cars with two-pedal control, using epicyclic transmission, as opposed to hydraulic turbo-transmission.

I have also paid a visit to the Army Apprentices School at Arborfield, near Reading. This was a real eye-opener to me.

Entrants for these courses are taken straight from school, and the entrance examination is one in English and Maths. only. The boys get reasonable pay, and good food.

By the way, the lads have a wonderful time taking engines of motor cycles, cars and lorries to pieces and finding what makes them "tick". They get the chance to do a bit of driving, too, of course.

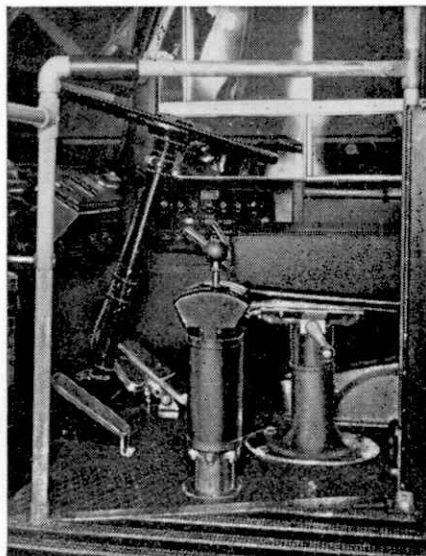

The gear change control in a Leyland bus fitted with the new pneumo-cyclic gear-box.



The 500th Boeing C-97 Stratofreighter leaving the assembly line. Photograph by courtesy of the Boeing Airplane Company, U.S.A.

Air News

By John W. R. Taylor

Five Hundred Stratofreighters

By turning out an average of one C-97 Stratofreighter a day for many months, Boeing had completed 500 of these big 175,000 lb. multi-purpose transports by February of this year. The illustration above shows the 500th aircraft leaving the assembly line at the company's Renton, Washington, plant.

C-97s are standard long-range transports with the U.S. Military Air Transport Service, and were the principal type of aircraft used for air evacuation of wounded troops from Korea, carrying up to 83 stretcher cases at a time. But their biggest job today is to serve as flight refuelling tanker-transports for B-47 Stratojet atom-bombers and F-84 Thunderjet fighter-bombers of the U.S.A.F.'s Strategic Air Command. Carrying a quickly-removable "flying boom" refuelling pack under their rear fuselage, they are able to accompany and refuel the warplanes on long-range non-stop missions over the Atlantic and Pacific; and 20 KC-97 tankers are attached to every 45-plane wing of B-47s.

Million Dollar Cargo

Few aircraft have carried a more valuable cargo than a K.L.M. Douglas DC-6A transport which flew into Prestwick Airport some weeks ago from New York, and few visitors to Britain are more popular with the younger generation than its V.I.P. passenger, *Trigger*, famous mount of cowboy film star Roy Rogers.

A record crowd of boys and girls were at the airport to welcome *Trigger*, who is insured for one million dollars. I wonder how many of the aircraft spotters among them noticed that *Trigger's* flying horsebox was itself a very famous aircraft,



Pamela Hislop, daughter of an airline officer, was the first to mount Roy Rogers' famous horse "Trigger" after he arrived at Prestwick Airport, Scotland, last February, in a Royal Dutch Airlines DC-6A.

namely the DC-6A which won the transport section of last year's London-New Zealand Air Race? It can be seen in the background of the bottom picture on this page.

K.L.M. Registrations Changed

The DC-6A illustrated will not carry the registration PH-TGA on its fin much longer, because all K.L.M. aircraft are being given new registrations which will indicate clearly their maker and type.

The Dutch international civil markings "PH" will, of course, remain; but the next letter will in future show which factory supplied the aircraft and the fourth letter will indicate the type. Thus, Douglas aircraft will be registered PH-D—, Convairs PH-C— and Lockheed aircraft PH-L—. Super Constellations, for example, will become PH-LKA, PH-LKB and so on. It will be interesting to see if K.L.M. change the registration of their Auster 5 photographic aircraft, which at present is, very appropriately, PH-OTO.

New Cockpit Light

A new lighting technique for instrument panels is being developed for the latest British aircraft. Known as the Thorn Plasteck system, it uses light bulbs buried in the instrument paneling. The Plasteck panels are made from a sheet of Perspex about 1/4" thick, covered by two layers of vinyl plastic coating, the first white and the second black, giving a tough matt black finish. The edge surfaces of holes cut in the panel to accommodate instruments, switches and control knobs are treated in the same way.

Small electric lamps, surrounded by a red filter, are embedded within the thickness of the panel; and wherever illumination is required the black outer coating is removed. When the lamps are lit, red light diffuses throughout the inside of the panel and escapes through the white layer wherever it is exposed.



The Douglas DC-7, the latest of the famous series of Douglas transport aircraft. It is claimed to be the fastest piston-engined air liner in the world.

Fastest Piston-Engined Air Liner

The new Douglas DC-7 transport, illustrated above, is the successor to the famed DC-3 Dakota, DC-4 Skymaster and DC-6, and is claimed to be the fastest piston-engined air liner in the world. Basically similar to the DC-6, it is more than eight feet longer and seats from 69 to 96 passengers. Four 3,250 h.p. Wright R-3350 Turbo-Cyclone engines give it a cruising speed of 365 m.p.h. over very long ranges, and an interesting feature of its design is the use of the new, tremendously tough, heat-resisting metal titanium for the engine nacelles and firewalls.

So far 58 DC-7s have been ordered by American Airlines, United Air Lines, Delta-C & S. Airlines and National Airlines. The first production machines are due for delivery later this year.

Flying on the Ground

Crews of the R.A.F.'s latest jet aircraft will complete much of their early flying training on the ground as a result of a recent Air Ministry order for electronic Flight Simulators—"classroom" replicas of the cockpits of new fighters and bombers.

Simulators are being built for each of the new "V" bombers—the Valiant, Vulcan and Victor, and a jet-fighter simulator is already in use. Naval crews are also to have a number of ground trainers for the Fairey Gannet anti-submarine aircraft. Some will be big enough to accommodate complete crews, who will be briefed in a special room before entering the cockpit which will be fitted with every instrument, control and piece of equipment found on the actual aircraft. Training "flights" may last for three or four hours, achieving a high degree of realism, with engine noise, full radio and radar operation and simulated emergencies, without any of the dangers of flying and at much lower cost.

34-Ton Fighter

Avro Canada have received a contract for two prototypes of their CF-105 all-weather fighter design. Unofficial reports say that it will be a 1,200 m.p.h. delta with almost dart-shape planform and a tailplane. Its twin engines may be either Avro Canada Wacondas or Rolls-Royce Conways, and its loaded weight will probably reach the fantastic figure of 34 tons. The specification calls

The neat little Italian Piaggio P.149 referred to on this page.



for an armament of air-to-air rockets and a range of more than 1,500 miles.

Another Air-Shipping Link-Up

Latest and most important link-up between British shipping and independent airline interests is the purchase of a majority holding in Britavia Ltd., by the P. and O. Group. Britavia control both Silver City Airways, operators of the popular cross-Channel vehicle ferry service, and Aquila Airways, Britain's only flying boat operators, who recently offered more than £1,000,000 for each of the three Saunders-Roe Princess flying boats.

Other recent air-shipping link-ups concerned Hunting Air Transport and Clan Line Steamers, and Airwork and Furness Withy.

New Italian Lightplane

Latest product of the Italian Piaggio company is the neat little Type P.149 four-seat touring and military liaison aircraft illustrated at the foot of this page. It is basically similar to the two-three seat Piaggio P.148, which has been adopted by the Italian Air Force as a standard basic trainer. The most important changes are the larger cabin, more powerful 260 h.p. Lycoming GO-435-C2 engine and a retractable nosewheel undercarriage in place of the P.148's fixed tailwheel type.

The P.149 is of all-metal construction and is fitted with dual controls. Its wing span is 36 ft. 6 in., loaded weight 3,637 lb., and it has a range of 530 miles at a cruising speed of 155 m.p.h.

One Thousand British Transport Aircraft

Since the second World War the British aircraft industry has built 1,000 commercial transport aircraft for operators at home and abroad. Many of them have, of course, been smaller types like the Dove and Heron; but it is significant that nearly half of the 130 transports due for delivery this year will be turbine-powered air liners—Comets, Viscounts and Britannias. Latest order is from Air France, for three more Comet 2s.

Mysterious Orchids

By M. A. Savonius, Dip. Hort.

IF you have ever visited a big flower show you will have seen at least some of the beautiful tropical orchids that are grown in heated greenhouses in this country. With infinite care and patience skilled gardeners are continually producing new and magnificent hybrids, even lovelier than the parent plants, and many of them are later exported and help to bring foreign currency into England. But among all these fine plants you will never see a native British orchid, with the exception of an occasional lady's slipper plant displayed in a rock garden, because they are so difficult to raise that they defeat even the greatest experts, and their seeds are so tiny that they cannot be handled like the seeds of the large exotic kinds.

It is not just a fancy to think that there is something special about an orchid, even if it is a quite common one like the early purple orchid that you can see flowering by the road side in May. Orchids really are different from other plants and their life history is incredibly strange. When gardeners first tried to grow tropical orchids from seed they found to their dismay that the seeds just would not germinate, however carefully they were sown and tended, but occasionally a seedling plant would spring up in the same pot as the parent. This gave a clue to the mystery and about fifty years ago botanists discovered that orchid seeds could only germinate in partnership with a certain kind of fungus, and that this fungus could usually be found in the soil near the roots of the parent plant.

Orchids produce a very great number of seeds, but unlike the seeds of other plants, they have no stored nourishment with

which to start their growth. If they are to develop into plants they must receive outside help immediately, otherwise they will just die. This vital help is given, quite involuntarily, by a fungus known as mycorrhiza, provided the seed is lucky enough to fall in a place where this fungus grows. The fine fungus threads penetrate the seed, but instead of destroying it, this attack acts as a stimulant, because the seed is able to utilize the prepared nourishment which the fungus contains and so begin its own life.

In a series of attacks and counter-attacks the orchid seed and the fungus continue to live together, and very, very slowly a small underground tuber, known as a protocorm, develops in the soil. Nothing at all is seen above ground for some time and even the fastest growing of our native orchids does not show itself for two or three years. Many of them take eight or ten years; the lady's slipper does not appear for fifteen years after germination has begun, and it may be another four or five years before it flowers.

When the first green leaf has developed the new orchid plant enters upon a different stage of its life. Now it is able to provide some of its own food, like all other green plants, and as it grows larger it becomes more and more independent of the fungus. Many orchids indeed can finally manage entirely on their own, but two of our natives, the coral root and the bird's nest orchids, are compelled to rely completely on the activities of the mycorrhiza all through their lives. They are known as saprophytes and have a peculiar yellow look because they lack chlorophyll. They usually grow in the very darkest depths of woodlands, where the sun's rays seldom penetrate, because they are unable to

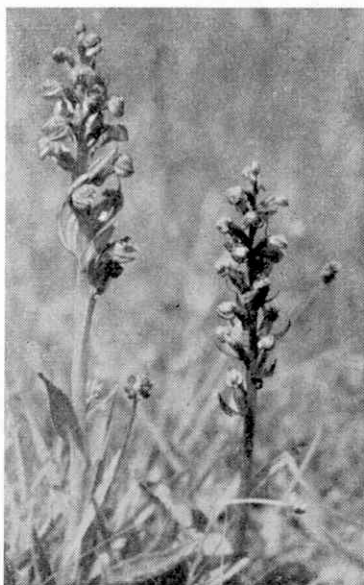

The curious Frog Orchid has green flowers.

benefit by sunlight and are quite happy without it.

It is not only in germination and growth that orchids are different from ordinary plants. Their flowers also have a very special character of their own. They are always irregular in shape and in most cases the lower petal in particular, called the "lip," develops out of proportion to the others. Often it forms a sort of platform on which insects can rest when visiting the flowers, and it is usually spotted or striped or cut into lobes of varying length.

In the lizard orchid the central lobe is so long, and twisted in such a curious way that it looks like the tail of some small reptile. In the monkey orchid and the man orchid the lip resembles a tiny figure with arms and legs. The frog orchid has greenish flowers that look rather like baby tree frogs; and the bee orchid and spider orchids resemble their namesakes so closely that botanists believe that these creatures make a mistake and visit the flowers in the belief that they have found another member of their own species.

Most of our orchids rely on insects to pollinate them, and with the exception of the lady's slipper, they all have their pollen grains joined together in club-shaped masses called *pollinia*. These are placed in such a position in the flowers that when they are ripe, the slightest touch will dislodge them and transfer them to the head or back of the first insect which visits the plant. Here they adhere firmly, either by



A group of those fascinating flowers, the Early Spider Orchids.

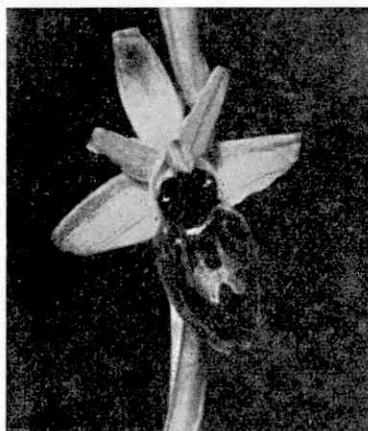

How the Early Spider Orchid obtained its name is well suggested by this close-up view of a single flower, which looks as if a spider had settled on it.

means of sticky discs at their bases or by the aid of a quick-drying liquid cement produced in the flower and released in a kind of miniature explosion just at the critical moment. At first these pollinia stand erect, but very soon they bend forward so that the insect appears to be carrying a pair of horns, and when it enters the next flower the pollen at once comes into contact with the sticky stigma.

No part of the British Isles is entirely lacking in orchids, and you may even find them in the Shetland Isles and in the Orkneys. But the greatest number of different kinds are to be found in Kent. Some of them, the bog orchids and the twayblade for instance, are so insignificant that you might well overlook them, while others, such as the large helleborines, are so striking that you could not possibly miss them. Some of them are curious rather than beautiful, and while there could scarcely be a scent more delightful than that of the white butterfly orchid or the pink fragrant orchid, the lizard orchid smells unpleasantly like a billy goat.

If you are interested in orchids and would like to learn more about our native species you should read a book called *Wild Orchids of Britain*, by V. S.

Summerhayes. It is full of the most interesting information about these aristocratic plants and explains in great detail their curious life history. When you come to realise what a slow, and one might even say

(Continued on page 260)

From Our Readers

This page is reserved for articles from our readers. Contributions not exceeding 500 words in length are invited on any subject of which the writer has special knowledge or experience. These should be written neatly on one side of the paper only, and should be accompanied if possible by original photographs for use as illustrations. Articles published will be paid for. Statements in articles submitted are accepted as being sent in good faith, but the Editor takes no responsibility for their accuracy.

PICTISH BROCHS IN GLEN BEG

Visitors to the Kentish coast will have seen the Martello Towers, built as a means of defence against the threatened invasion of England by Napoleon Bonaparte. I wonder how many readers have seen the far more interesting defence towers, or brochs as they are called, built in Scotland about 2,000 years ago. These were not normal dwelling places. Their builders lived in huts similar to those made by all primitive peoples, but they were built to accommodate the herds and flocks and their owners when danger threatened.

In view of their great age it is amazing that any of them should still remain standing, but in the more remote parts of Western Scotland, there are many good examples to be found. The brochs were built in the valleys, near the banks of a river, and the accompanying illustration shows part of one of the three in Glen Beg, near Glenelg, in Western Ross.

A broch consisted of a circular tower with double walls, several stories high. There was one low, narrow doorway through which sheep and cattle could have been driven, and which could easily be defended by one or two men. The rest of the tribe would be safe in the many chambers built in the thickness of the walls, and reached by a stone stair.

Originally the brochs were 40 to 50 feet in height and from 40 to 60 feet in diameter at the base. The walls sloped gradually inward towards the top, and most probably the brochs were open to the sky.

Thanks to the good attention of the Ministry of Works, these ancient monuments of early Scotland are protected and preserved for posterity.

P. M. URWIN (Stratford-on-Avon).

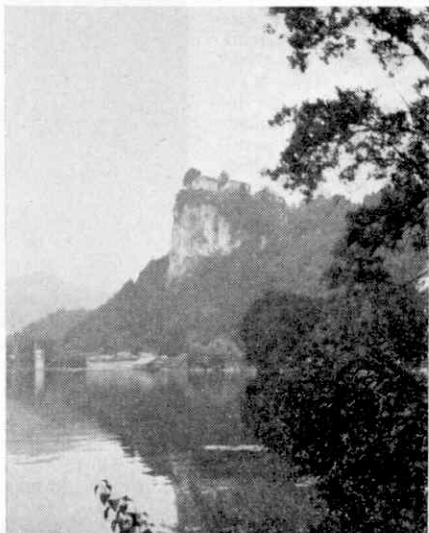

Lake Bled seen as the early morning mist rises from its surface. Photograph by M. C. Foot, Southampton.

LAKE BLED

Tucked away deep in a hollow between the Julian Alps and the Korvanki range of Northern Yugoslavia, like a picture out of a fairy tale, lies the most beautiful lake of Slovenia and one of the beautiful lakes of the Alps—Lake Bled.

The calm blue mirror surface of the lake on which sunbeams glitter, the little white church on the island in the middle of the lake, the old red tiled ivy covered castle, beautiful in decay, perched precariously on a steep rock high above the water, and the shining white snowfields of the mountains in the background, blend into a picture of sublime beauty. On the eastern shore in contrast to the others where patches of green woodland alternate with picturesque and delightful little wooden houses decorated with original ornaments, one can see large modern hotels, parks, a promenade and expansive beaches.

Bathing is a favourite pastime during the whole summer, as the lake's water is pleasantly warm and has certain curative properties because of its submerged thermal chalybeate springs. In winter the summer water sports, mountaineering, hunting and fishing are replaced by skating and by skiing on the excellent slopes in the vicinity. For less energetic visitors it can be an equally thrilling experience just to sit on the lake's edge and to hear the sweet strains of a Strauss waltz floating gently, it seems from far away, across the peaceful waters.

It is small wonder that Lake Bled has become an international alpine holiday resort with a reputation renowned far beyond the borders of Yugoslavia. Here surely is Elysium! M. C. Foot (Southampton).



The simple, narrow doorway of one of the brochs in Glen Beg, Western Ross, Scotland. Photograph by P. M. Urwin, Stratford-on-Avon.

BOOKS TO READ

Here we review books of interest and of use to readers of the M.M. With certain exceptions, which will be indicated, these should be ordered through a bookseller.

"THE RAILWAYMEN'S YEAR BOOK"

Railwaymen's Publications Ltd. 4/-

This is a comprehensive reference book to which railwaymen can turn with confidence when in need of facts or figures concerning their industry. It contains much information useful to railway staff in connection with their job, such as details of Welfare arrangements, the Railway Convalescent Homes and various associations, unions and other organisations formed to look after the interests of railwaymen. Details are given of progress and further projects in the various Regions and there are short reviews of through named trains and of important train services overseas, while the activities of London Transport Railways are included.

The book has over 40 illustrations, most of them well chosen for their purpose. Railway staff may order it direct from the publishers, Railwaymen's Publications Ltd., Vernon House, Sicilian Avenue, London W.C.1, in lots of eight or more copies at 2/6 per copy, remittance with order. Otherwise, the price is 4/3 per copy by post, or through any railway bookstall at 4/-.

"RADIO CONTROL OF MODEL AIRCRAFT"

By G. SOMMERHOFF (Percival Marshall 9/6)

This comprehensive book on radio control of model aircraft has been written mainly for the aeromodeller lacking previous experience in radio work, but it is hoped that the later chapters will serve as a stimulus for more advanced experimental work. The early part of the book explains the functions of the various components and the basic essentials of radio, with particular emphasis on the equipment that is used for the control of aircraft models. Subsequent chapters deal with the theory and construction of transmitters and receivers, and with tuning and adjusting. Circuits for various control systems are dealt with, and it is worth noting that all the methods of control described have been developed, constructed and used by the author, with the assistance of the members of the Dragon School Science Club. He has kept in mind the necessity of reducing the cost of radio control to a minimum, and to this end he has given full constructional details for all the equipment required.

The book is illustrated with a half-tone frontispiece and many line drawings.

"TRAINS ILLUSTRATED PHOTOREVIEW"

(Ian Allan 2/-)

This is a reprint in separate book form of railway photographs that appeared in special supplements published by *Trains Illustrated* during 1952. All are typical action pictures, and a splendid variety of train subjects is presented. Trains on railway by-ways in addition to those on the better-known main lines are included, and the scene in general is by no means monopolised by giant Pacifics, or even by important passenger trains. Even the ordinary goods train has something about it when it is caught by a discerning camera.

Few of the youngsters for whom this book is intended will complain of the entertainment provided and, naturally, the older enthusiast as well will find a great deal to interest him.

"ALL ABOUT MAKING DARKROOM GADGETS"

By L. C. MASON

"ALL ABOUT MAKING A FLASHGUN"

By M. M. WARNER

(The Focal Press 2/- each)

These are two recent additions to the now well-known pocket Focal Photo Guides. For darkroom work, just

as for any other, you need the right tools for the job. These are comparatively few and quite simple and, as the first-mentioned of these booklets shows, can be made quite easily for oneself with ordinary tools and ordinary materials. Various types of safelights, cabinets for general equipment and bottles of developer, etc., and a film drying rack are a few of the many gadgets dealt with, and emphasis is placed on simplicity and efficiency in describing them.

Any reader who has watched a Press photographer at work will have noticed him using a flashgun as an aid to getting the best picture possible. In the second of these little booklets the author gives detailed instructions for making this valuable accessory. In both booklets excellent half-tone illustrations show the stage-by-stage progress of the making of the various articles described, and neat line drawings of the various components will aid the reader to assemble the flashgun correctly.

"BRITISH RAILWAYS"

Mechanical and Electrical Engineer's Department
Bulletin No. 7

This is one of a series of Bulletins published by British Railways on performance and efficiency tests of various types of locomotive, several of which have already been referred to in the M.M. In it the working of the familiar W.D. 2-8-0 and the lesser-known W.D. 2-10-0 engines is investigated. The main purpose of the tests described is to provide data on which most economical working of the locomotive can be based, while at the same time meeting the requirements of traffic. The details given of course are of special interest to the locomotive engineer and student.

Copies of the bulletin can be obtained from the Publicity Officer, British Transport Commission, Room 263, 222 Marylebone Road, London N.W.1 for 10/- each including postage.

"MODELS AND MODELMAKING"

By T. CARRINGTON BRICH
(Perry Colour Books Ltd. 2/6)

This attractive little handbook, with many of its principal illustrations in colour, gives hints rather than detailed instructions for modellers in various subjects. General ideas are followed by notes on bridges and other forms of engineering construction applicable to miniature railways. Rolling stock and locomotive building in miniature is considered, while marine and aircraft modelling also receive some share of attention. The text is backed up by numerous illustrations, most of which indicate very clearly the various steps in modelling a particular subject.

THE S.E. AND C.R. LOCOMOTIVE LIST, 1842-1952

By N. WAKEMAN
(The Oakwood Press 7/6)

This is not a locomotive history in the accepted sense of presenting a popular illustrated account of the engines belonging to the constituent companies of the former South Eastern and Chatham Railway. Rather it is a numerical list giving classes, builders, building and withdrawal dates of the engines that have run during the past century on the Eastern section of what is now the Southern Region of British Railways. Numerous notes are incorporated and dimensions of the different engines can be obtained by cross-reference to a table that forms a useful section of the book. There are some diagrams of quite early types, but for the most part the illustrations are well reproduced half-tones, many of them not used before.

A considerable amount of research has been necessary to compile the list and the author must be congratulated on the thoroughness of his work.

Railway Photography in the West Country

By H. Gordon Tidey

IN previous articles I have referred to the lamentable fact that year by year it becomes increasingly difficult when arranging a photographic railway tour, to see at spots once so lucrative the necessary variety of motive power to make a somewhat extensive trip worth while.

A moment's consideration makes it clear that a trip to the old L.N.W.R., L. and Y., Midland or Tilbury lines produces precisely the same classes of engines. This applies also to the former G.N.R., G.E.R. and

better than repeat my fairly recent trip to the Devonshire end of the latter Region, with a day at Wellington, in Somerset, on the way and returning via Westbury.

Having settled this important point and having reached early July, I tackled the problem of impedimenta, more particularly with regard to the minimum number of pairs of trousers that it would be desirable to carry in view of the unfortunate experiences of last year, when I got into difficulties with sundry barbed wire fences.

I decided that one pair worn in the usual position and two spare pairs in the bag, complete with safety pins, should be sufficient to carry me through. I completed my packing, giving a final examination to the camera and accessories, having on one occasion some years ago arrived at my venue only to find I had omitted to bring the lens!

Starting from Barnet soon after 9 a.m. on a fine Tuesday morning I reached Wellington without mishap in the late afternoon. My intention was to try and find access to a spot

just east of Whiteball Tunnel, which leads to the summit of the celebrated bank and at which point engines are working all out at a moderate speed, often showing plenty of exhaust. So after obtaining suitable accommodation I did a bit of exploring with a view to being ready first thing in the morning.

I have already referred to the fact that in Devonshire no lanes ever lead to any point that one might reasonably expect, and I was now to discover that precisely the same thing applies to Somerset. The tunnel between Wellington and Burlescombe would appear to lie completely off the map and was apparently never built with an eye to the needs of poor railway photographers—in fact the longer I practice the more convinced I become of the existence of some sort of pact between



W.R. No. 5028 Llantilio Castle nearing the tunnel at the summit of Wellington Bank. The train is a down Torquay Express.

G.C.R., and in both groups extends to Scotland. As regards the Southern Region, we are faced with extensive electrification and only on the old L.S.W.R. do we still get a fair amount of steam haulage, but this is largely neutralised by the prevalence of Merchant Navy and West Country Pacifics, which are rapidly ousting all the earlier designs.

This being so there remains only the G.W. Section. This line once afforded the least variety compared with the others, but now provides us with numerous 4-6-0s in the shape of Kings, Castles, a few Stars, Halls, Manors and Granges, as well as a miscellaneous collection of goods and tank engines, which I have found in far greater variety than on other Regions.

After much consideration I was forced to the conclusion that I could not do

the gentlemen who are responsible for the layout of our railways, pledging them under penalties to make things as awkward as possible for this fraternity.

Anyhow, after having pursued several unpromising looking narrow lanes and finally descended a precipice, I found that I could reach an underbridge where I could climb to the line and reach a point on the inside of a curve, though with the light on the far side of the train. Having thus prepared the ground I returned to my hotel and enjoyed the sleep of the just.

Next morning produced a nearly cloudless sky, so I set off with a light heart for the spot I had previously discovered. Half way down the precipice in the narrowest part, making passing impossible, I met a tradesman's van ascending. This would appear to be an everyday occurrence, for the van, no doubt quite used to the performance, backed right down to the bottom, very skilfully negotiating the many hairpin corners. Having arrived safely at the foot I parked the car in a field adjoining a farm cottage and was all set for a full day's enjoyment, having brought some lunch with me. As I was getting out of the car the farmer came out of his cottage and engaged me in a conversation the bulk of

which was quite unintelligible, but he finished up by presenting me with a number of outside lettuces, of which I understood he had a glut. I enjoyed one of these at supper that night.

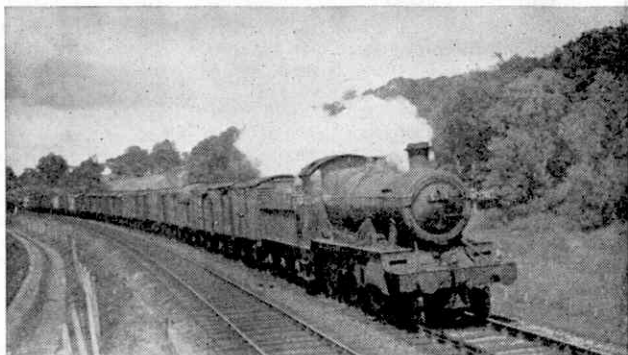

One of the useful Swindon 2-6-0s No. 5339 on an up freight train near Cullompton.

The line at this spot is comparatively busy, as in addition to being the main line to the West, it also carries traffic for branches such as Torquay and Kingswear. In consequence there is a frequent service of both goods and passenger trains and a very pleasing variety of locomotives. During the day I saw such trains as *The Cornish Riviera*, the *Cornishman*, *Torbay Ltd.*, and a number of Penzance and Plymouth expresses, besides several slow trains, locals and goods of all sorts. I also noted Kings, Castles, a Star, Saints, Halls, Manors, Granges, Moguls, Austerity Goods 2-8-0s and 0-6-0s besides several 2-6-2Ts. Quite an interesting variety. Except on Fridays and Saturdays, trains are not piloted, although through goods trains have the assistance of a 2-6-2T at the rear, which drops off at Burlescombe, the first station west of the tunnel.

Having taken up my pitch I was successful in securing a nice record of an exceptionally clean Manor hauling a stopping train.



The Torbay Express leaving Torquay behind Castle class 4-6-0 No. 7029 Clun Castle.

After this there was a short gap, followed by the appearance of a through freight headed by an Austerity goods, making heavy work of the bank although assisted in rear by a 2-6-2T. After a further gap, during which the 2-6-2T returned light to Wellington, the next arrival was a Paddington-Plymouth express in charge of one of the ubiquitous Castles. Then another through goods, this time hauled by a 2-8-0 of G.W. design.

Meanwhile of course up trains were numerous, but owing to the situation I was not considering these, photographically speaking.

My next port of call was Newton Abbot, in Devon. Leaving Wellington the next morning, I took the Exeter road, but was soon arrested at Cullompton, where the G.W. line runs beside the road for some way and finally passes under it. This spot has assuredly been specially designed for railway photographers, because there is space in a lane to park a car, the curve is on the correct side and the sun in the afternoon is in the right direction. Here I obtained several attractive pictures and made a mental note to visit the spot on future occasions.

Proceeding via Exeter, at which busy city I took the avoiding road, I arrived in the late afternoon at Newton Abbot.

Newton Abbot, an important junction and railway centre, has also a commodious Locomotive Shed housing a large number of engines of varying classes. It is here that the heavy trains for the Penzance line pick up their pilots, in readiness for the mountainous track that faces them through Devon and Cornwall. Hard work starts almost immediately with Dainton Bank, with its gradient in parts steeper than 1 in 40, shortly after which the no less severe Rattery Bank has to be tackled.

About half a mile west of Newton Abbot is Aller Junction, at which point the line forks—to the right the line to Plymouth and Penzance and to the left that to Torquay and Kingswear. On previous visits I had spotted an overbridge, leading

from the main road to a farm, that afforded an excellent viewpoint for trains in both directions. Leaving this for a moment I proceeded with my pre-arranged programme and ran down to Kingswear. Here, from a point on the road one can get an excellent view of a comparatively short train in the station, showing the River Dart and the town of Dartmouth in the background, but for such trains as the *Torbay Ltd.*, occupying the whole length of the platform, it is impossible to include the engine and the whole train in the picture. Accordingly I made my way back to Paignton, where I was successful in obtaining a nice shot of the down *Torbay Ltd.* from the overbridge adjoining the station, much to the interest of a number of spotters who were operating on the bridge.

On Saturday I decided to have a day on the overbridge at Newton, previously referred to, having found it suitable enough to warrant expenditure of considerable time. But the weather decided otherwise! I arrived at the spot about 10 o'clock. For about an hour little of interest happened, and then rain started!



On the sea wall near Teignmouth. No. 4975 Umberslade Hall is hauling a down semi-fast for Plymouth.

As I had used up rather more plates than I had expected, I decide to cut out my visit to Westbury and accordingly made my way home by easy stages, speculating as to what success I might have achieved on one more annual week's trip devoted entirely to Railway Photography. In one respect I already knew I had been successful—I was taking back all three pairs of trousers, completely undamaged!

A Job for the Breakdown Gang

By S. C. Townroe, A.M.I.Mech.E.

EARLY one Sunday morning, when our household was enjoying that extra hour in bed, the telephone awakened me. "This is Control," said the speaker, and went on to say that a passenger train on the rural single line from Winchester Junction to Alton had broken down in the section between Itchen Abbas and Alresford. The driver had walked to Alresford Station, where he telephoned to tell Control that his engine, No. 30480, an 0-4-4 tank, was immobilised with a broken tyre on the right driving wheel. He had succeeded in stopping the train without further mishap, at a point some 1½ miles west of Alresford.

Control's first thought was for the passengers. Fortunately, the Hants and Dorset Company had been able to provide a bus almost at once from their Winchester garage, and this was already on its way to pick up the stranded passengers.

Now when an engine comes to grief with a mechanical defect on a single line it is always a difficult proposition to deal with, especially when, as in this instance, a crane is needed to lift the engine in order to effect repairs. The train was a pull-and-push one and the engine was pushing at the time, so the breakdown crane would have to approach it in the up direction.

This was not a case where the breakdown train could proceed at full speed to the scene. Arrangements would have to be made for its engine to run round it before entering the single line, and then to propel the crane head-on for six miles until it reached the crippled engine. Such a movement would, moreover, have to be made under special authority, to permit entry into the section already occupied by the stationary train.

Meanwhile the foreman of the gang went ahead with me, by car, to examine luckless No. 30480. We saw that the broken tyre was very loose and would have to be

removed on the spot. In the rare event of a breakage, the tension in the tyre causes it to spring open slightly. Obviously No. 30480 had run some distance with the brakes hard on before stopping, and the tyre had opened considerably in the process. And with some bumping!

A series of exploding detonators, placed in accordance with the Rules to protect a disabled train, heralded the arrival of the crane. The front of No. 30480 was lifted sufficiently to take the coupled wheels off the rails, after the coupling rods had been removed, while an oxy-acetylene torch was used to cut the tyre into three pieces. On rotating the driving axle with

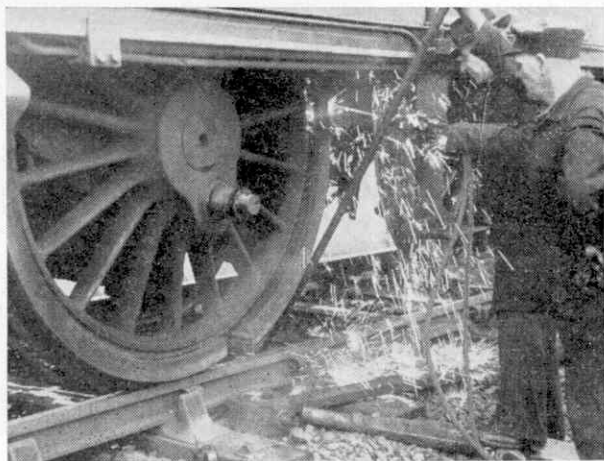

Cutting off the broken tyre of S.R. locomotive No. 30480 with an oxy-acetylene torch.

crowbars, the pieces of tyre then fell to the side of the track.

The next operation was to place packing on top of the axle-boxes of the leading wheels; by this means, when the engine had been lowered by the crane, the driving wheels remained clear of the rails by an inch or so. The engine was then movable on six of its eight wheels, although not exactly "on an even keel"! Finally, as it was slowly towed away by the breakdown train, the small crowd of spectators watched it disappear, and then went home, like us, to Sunday dinner.

DINKY NEWS

By THE TOYMAN

More New Models

IN my last article I was able to give news that had been eagerly awaited by all Dinky Toys collectors. After an interval of several months, for reasons which I have explained previously, two new models were added to the range. This month again I have good news for Dinky Toys enthusiasts, for another two new models have now been introduced, and there is the Dinky Toys Express Passenger Train as well!

The latest additions are based on subjects of widely different types, and is each made with the accuracy and attention to detail

to display the flowing lines of this new model, and it is shown passing through a gateway at the entrance drive to a country residence.

It is surprising how much added interest a simple scene of this kind gives to a road approach to a village or town in a Dinky Toys layout. Very little space is needed for the scene, for the residence can be outlined on the backcloth of the layout and half hidden by trees. The gates opening on to the road are placed at the end of a winding drive that blends into the backcloth.

Fig. 1. The Dinky Toys Studebaker Land Cruiser makes a realistic picture as it passes through the gateway of a country residence.



that has now become an accepted feature of every Dinky Toys model.

The first of them that I want to mention is one that is sure of an enthusiastic welcome from all collectors. I have been asked many times for more models of American cars, and now here is a handsome model of the stylish Studebaker Land Cruiser. As a matter of fact, it was intended to make this model available some time ago, but production was unavoidably held up. Now at last the Studebaker is on sale, and I am sure that after a glance at its picture in Fig. 1 every collector will agree that it has been well worth waiting for.

As a change from the usual "catalogue" picture I have arranged a simple setting

Scenes of this kind are often useful for filling in awkward corners in layouts, as the drive sweeping into the background provides an atmosphere of depth in the scene, and tends to distract attention from the sharp corner.

The gates themselves are quite easy to make from thin strips of cardboard glued together. It is a good idea to draw a plan of the gate to scale on a piece of thick cardboard. The strips of cardboard can then be cut to the correct length easily and quickly by measuring them against the plan, and they can be held in position while the glue sets by pins pushed into the base cardboard.

The gate pillars and the walls are made

from thin cardboard bent to shape and glued, and the mortar lines are marked out in black ink. The ornamental balls on the tops of the pillars are made from balls of tinfoil. They seem rather rough and weatherbeaten, but then this is very often

model, as you will see from Fig. 2. This picture shows the tank climbing a rise in hilly country, and gives a good idea of the sturdy appearance and the impression of power created by the model. It is splendidly proportioned, and the accurate casting



Fig. 2. The Centurion Tank in action! A fine picture of the Dinky Toys model climbing a slope in hilly country.

the case in real life, as gate pillars have a notorious habit of getting in the way of traffic! The gates are hinged on short pieces of cloth glued between the edges of the gates and the pillars.

Now I come to a new Dinky Toys army model that is sure to create a stir among admirers of Dinky Toys military vehicles. Since the introduction of the Scout Car last November I have received many appeals for a model of the Centurion Tank, and now I am glad to say that a fine model of this machine is available in the rapidly increasing range of military vehicles.

The Centurion is a most impressive

reproduces faithfully the exterior details of the actual Centurion. The model runs on rubber tracks, which are ribbed to resemble the plates that form the tracks of the real machine, and are supported by wheels and rollers so that they turn quite smoothly. The most prominent feature of the model is its imposing gun, which is carried in a turret arranged so that it can be swung round just like the real thing.

The Dinky Toys Centurion is finished in the correct shade of green, and it carries Royal Armoured Corp signs at the front and back just like the Scout Car and the Army Covered Wagon.

Fig. 3. A convoy of Centurion Tanks rounding a bend in a country road. The convoy commander in his Scout Car is overtaking the supply wagon to resume his position at the head of the column.

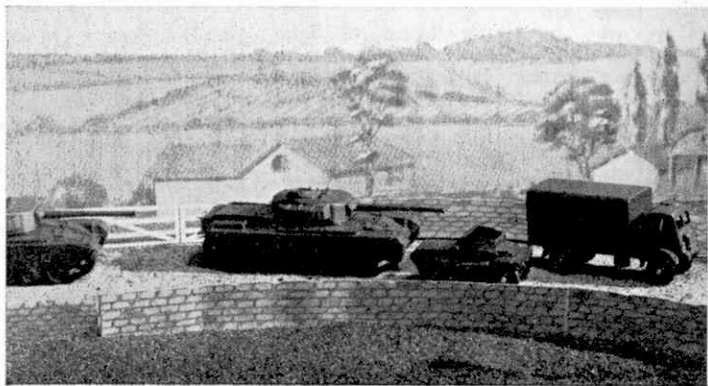



A tense moment—the start of a cycle speedway race, during the first indoor meeting of this kind, held at the Empress Hall, London, in 1950.

and backyards, and on them the boys, sometimes in their best suits, raced round and round for hours on end.

The sport was not confined to London, even in its early days. Boys in Birmingham and Glasgow were soon building their own tracks, and they suggested to those in London that a series of "test matches" should take place. The first of these "tests" took place in London in 1946, between the Perry Barr Juniors from Birmingham and the Stratford Hammers from London. Birmingham won by the odd point—48-47.

By this time, teams were mushrooming all over the country, Becton Aces, Thameside Tigers, Crossmyloof Giants, Craighton

Eagles and many others, all with excitingly weird names.

By 1947 it was obvious that cycle speedway racing had come to stay. Tired and dusty boys would go home and tell their parents all about the races they had won—or lost—and of course their parents then just had to visit the local track to see for themselves. From this humble

RATHER more than eight years ago British boys invented a great new thrill and adventure—cycle speedway racing. Today it is one of the most popular all-youth amateur sports.

Many *M.M.* readers probably have watched a cycle speedway match in progress, and have seen the young riders in crash helmets and old leather jenkins

racing on second-hand cycles around one of the cinder tracks that are dotted all over the country. But I expect that there are

others who have not heard of this comparatively new sport, which is really the junior version of motor speedway racing, and will welcome this explanation.

Cycle speedway racing started soon after the last war. Cities and towns in many counties were mostly rubble and ruin, and a group of lads in East London decided to put some of the bombed sites to good use. They set to work in organised parties and cleared the sites, salvaging large stones and bricks, which later they sank into the earth in the shape of oval tracks. Earth, sand and cinders were collected and rolled into the ground; old bicycles—roadsters, sports, tourists and racing machines, and even grocer's bikes—were uncovered from sheds

Cycle Speedway

A Sport that British Boys Invented!

By Graham Payne

beginning, large crowds were attracted. As early as March 1949, the Foulston Eagles team at Plymouth had as many as 5,000 people turning up to watch their meetings. Very shortly, fathers accepted official posts as team managers and stewards; mothers and sisters would cater for refreshments or become club secretaries.

London, Birmingham, Manchester and Glasgow formed their own Control Boards to govern the sport and drew up rules and regulations for racing.

In Continental countries, where motor speedway is prominent, cycle speedway has gained a sure footing. Ireland, Holland, Sweden, Australia, New Zealand, South Africa and parts of America have their own small cycle speedway leagues and organisations. Today Britain's greatest rival is Holland, where many red-shale surfaced

tracks have been built by local councils and large numbers of youths attracted. In 1950 a visiting Dutch team defeated an England team in London 49-47.

The sport in this country now has the active co-operation of the National Playing Fields Association, the Federation of Boys' Clubs and the London County Council and many other bodies. The first Council-built track was laid at Northwood in Middlesex, where a corner of the local recreation park was fenced off and converted into a pukka track, with electrically-operated starting tapes. In more recent years, the National Playing Fields Association have designed a special cycle speedway track with banked bends and "pits" for the repairs of machines. Already the more ambitious clubs are building their own tracks to these new requirements, and many are racing in the dark winter evenings with the aid of floodlighting.

One of the best tracks in the country is at Walton-on-Thames, where the local team, Walton Swans, have, with Council aid, laid a fine cinder track complete with special "pits", a wooden stewards' box, electric starting tapes, riders' safety fence and a

loud-speaker system. Riders and supporters organised attractive grass and tulip flower beds in the track centre.

Two leading cycle manufacturers in this country recently produced special bicycles



Trying to overtake the leader, a competitor on the track built by the Hayes Council, broadsides too sharply coming out of the bend and his effort ends in disaster. The illustrations on this page are reproduced by courtesy of the "News Chronicle."

for cycle speedway racing. These have wide sweeping handlebars, low-cut frames and fast gear ratios. A tyre manufacturer has also produced a pair of cycle speedway tyres, with extra-knobby treads that will hold on the cinders and in skids in broadsides on the bends. Rules insist that for racing the machines must be stripped of

all dangerous fittings, such as mudguards, lamps, brackets, dynamos, wing-nuts and brakes, but naturally brakes must be fitted when riding to and from the track.

To join a team you need an old bike and the urge for adventure, plus a certain amount of patience. Most of today's top riders started off by approaching the manager of their local team and badgering him for a trial spin round the track.

You can find where your local team is either from your local paper or from the Cycle Speedway Annual, in which are many

(Continued on page 260)

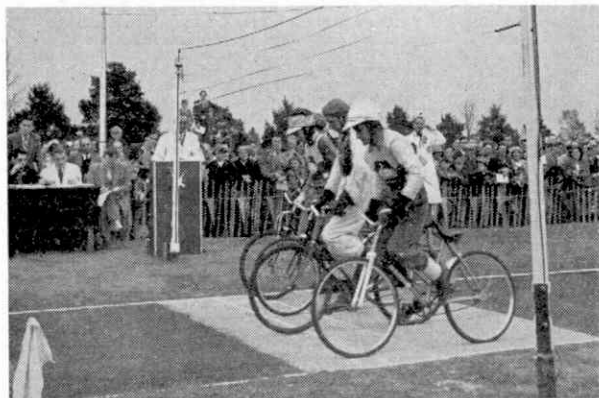

A scene from the 1952 National Championship Final. The cinder track is neatly made, there is a safety fence and a fine starting gate—and a huge crowd.

The World's Richest Island

By Francis J. Knight

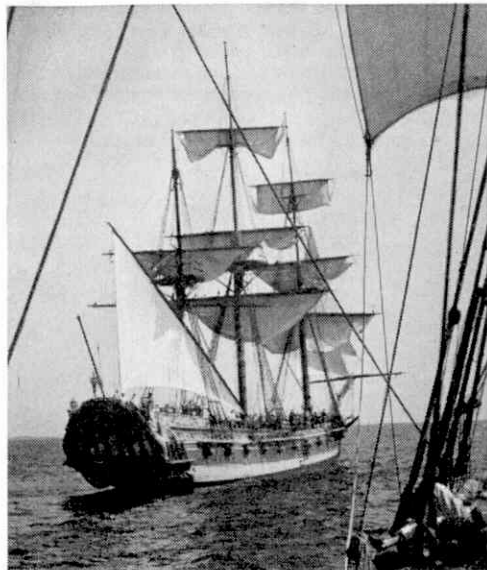

A pirate ship, in the version used for filming *The Crimson Pirate*, the Warner film in which Burt Lancaster starred.

HOW would you like to sail away into the Pacific, spend a few weeks on a tropical island and come back with pirate gold worth nearly a hundred million pounds?

Fantastic? No. It could be done and, one day, it might be. For there is such a treasure island, and its name and location are no secret. The island's name is Cocos and the location just 300 miles South West of Costa Rica.

In buccaneering days, Cocos was a great pirates' base. In fact, if you stayed there long enough, you were pretty certain to meet almost everybody who amounted to anything in the business conducted under the skull and crossbones houseflag.

The attraction of little Cocos was its isolated position and good natural harbours. There are also coconut palms, with fruit to be had for the picking, and waterfalls cascading from the cliffs to form fresh water pools on the shore below. Many a pirate vessel laid off the still, turquoise waters of the island's Chatham Bay to refit and rest its villainous crew after a successful raid on fat Spanish galleons wallowing home with the wealth of the newly discovered Indies in their holds.

The evidence of that hundred million being buried somewhere inside the 13-mile circumference of Cocos is pretty conclusive. Before you sail, you will like perhaps to have some of this evidence!

It is known for certain that Captain Edward Davis, a very successful pirate captain, put into Cocos in 1686 in ships weighed down with loot from a fleet of Spanish vessels that he and his fellow cut-throats had boarded and captured. So great was the weight of the treasure in the hold of Davis's own vessel *Batchelor's Delight* that she all but foundered on the way to Cocos.

The pirate fleet of ten ships dropped anchor in Chatham Bay, and the spoils were divided among the thousand men of the ships' companies. The pay off was no niggardly affair. Doubloons and gold pieces were measured out by the jugful.

Davis, of course, took the biggest share of the booty for himself. During the next few days, he

and two of his officers made several trips up the rough slopes from the bay, dragging with them a dozen or so heavy oak chests. Since it would have been impossible for the three men to have dragged these chests very far, it is almost certain they were buried somewhere close to Chatham Bay. So far as is known, they are there still, just waiting to make somebody a millionaire.

Unlike most of the pirate leaders, Captain Davis did not end his life on the gallows. He retired to live in the recently discovered colony of North America, and there is no trace of his returning to Cocos to collect the loot. The fate of the two officers is not in the record, but Captain Davis was far too shrewd to allow two men who knew the secret of his hiding place to live long enough to tell the tale. So, there you are! Treasure number one, close to Chatham Bay.

The second treasure reputed to have been buried on Cocos was put there by Battling Benito, one of the most infamous monsters who ever harried the seas. Details of his caches, estimated to value more than two million pounds, are unknown. This is because Benito followed the usual pirate custom and murdered his helpers as soon as the job was done.

As we don't know quite where to start digging for Benito's loot, perhaps we'd better pass it up. Benito's five million is only small fry when we talk about the next collection. The biggest and best treasure of Cocos is a hoard reckoned to be worth something like fifty million pounds cached by a British captain, Edward Thomson, little more than a century ago.

The fantastic tale of Thomson's treasure reads like the script of an improbable movie thriller. The opening scene is the city of Lima, Peru, with Spanish grandees racing around in panic as messengers bring news of the rapid advance of the liberating armies of General Bolivar. Lima was the treasure centre of Spanish America. It was there that the masses of gold and treasure extracted from the Incas by every refinement of torture were stored for shipment home to Spain. The Spaniards knew that Lima was in no state to resist a siege by Bolivar's forces, and they decided to ship themselves and their treasure back to Spain while the going was still good.

It happened that a small British brig *Mary Red* was lying in the roadstead at nearby Callao harbour. The master, Captain Thomson, was sent for and contracted to take the Dons with their families and the treasure home to Spain. Huge chests filled to the brim with gold, glittering jewels and precious stones were carted to Callao and shipped on board the *Mary Red*. The Inca's treasure was followed by the Governor and other notables, with their families. Unescorted, the small brig weighed anchor and started on the long voyage to Europe.

The first night at sea seemed quiet and peaceful to the Dons, but just for the stupendous wealth in the holds had already set fire to the blood of both master and crew. Just after midnight, on Thomson's orders, the crew crept up to each of their sleeping passengers in turn, men, women and children alike, slashed their throats and threw the bodies overboard.

All this wonderful wealth was theirs! Thomson and his men decided that their best policy was to cache the proceeds of their treachery in some remote spot until the affair had blown over, then pick up the treasure, share it out and live in luxury on the

proceeds. Remote Cocos Island was selected as the hiding place.

So, a few weeks later, the *Mary Read* dropped anchor in Chatham Bay. The treasure was hidden in a cave close to one of the two small streams that flow into the bay, and the miscreants sailed away—straight into the path of a British frigate. The amateur pirates were hanged then and there, except Thomson and one officer. Their lives were spared on condition that they led a landing party to the treasure.

Once again the two pirates landed on Cocos, this time with a guard of British sailors. Somehow, they managed to dodge away and hid in the dense jungle. After wasting several days combing the island, the British captain was forced to abandon them and sail away.

Months later, the two castaways were picked up by a whaler which called at Cocos for water. Thomson's companion died on the way home. Thomson himself lived on in poverty in Newfoundland. For twenty years he tried frantically to get someone to take him back to Cocos. Unable to say who he was, or why he was so desperately eager to go, he failed every time.

As he lay dying, Thomson at last confided the secret of the buried loot to a man named Keating, who had picked him up in the street and looked after him during his illness. Keating at once set about finding the treasure, and in 1841 sailed in the brig *Edgecombe*. Captain Boag was in the secret, but nobody else. Landing at Chatham Bay, these two men followed the crude chart left by Captain Thomson and found the entrance to the treasure cave. Slashing away the tangle of jungle vines, they forced their way inside. The place was stuffed with sacks and barrels—some had split open, covering the floor with mildewing gold coins. Heaps of rubies, emeralds and sapphires scintillated and deflected the light from their guttering candles.

Had Keating and Boag acted like sensible men, this would have been the end of the story of Thomson's loot. But the sight of the treasure seems to have driven them completely crazy. Although there was wealth enough in the cave to make them all rich men, Keating and Boag decided to keep their find a secret from the crew. In their insane greed they forgot the obvious fact that they couldn't move more than a fraction of the treasure without help, and that it would be impossible to conceal what they did bring away.

The crew were already suspicious, and when the



Here is Burt Lancaster as Captain Valbo, with Nick Cravat as Ojo, at the wheel of the pirate ship, as it nears the island of St. Pirot.

two men returned to the ship insisted that some of the crew should go with the next day's expedition.

That night Boag and Keating, the madness of gold-lust on them, clambered down a rope at the ship's side and silently rowed ashore. The infuriated crew searched for them among the tangled undergrowth, jungle creepers and briars in vain. Like Thomson and his companion, Keating and Boag remained hidden while their ship sailed off. The departure meant, of course, that they had lost the only means of getting the treasure away.

Again the story is carried forward by the chance arrival of a whaler. The crew found Keating half starved and babbling a dozen different stories to account for the death of his companion. He returned from Cocos without so much as a single gold coin to reward him for all he had endured.

Years later Keating led another expedition to Cocos, but mutiny among the crew forced the party to return empty-handed. Before setting out Keating insisted that he should not be asked to enter the treasure cave. It seems likely he knew the body of his murdered companion would be found there. So, if you are lucky enough to locate the cave, you may find a skeleton in the cupboard.

After Keating's death, other expeditions, relying on detail he is supposed to have given, searched in vain for the treasure. Although Thomson's cave is known to be close to one of two small streams that flow into Chatham Bay, the entrance is no wide open door with "Welcome" on the mat. Jungle briars, creepers and liana have hidden the cave entrance behind a solid mass of vegetation. So you will need to be ready for some hefty axe work.

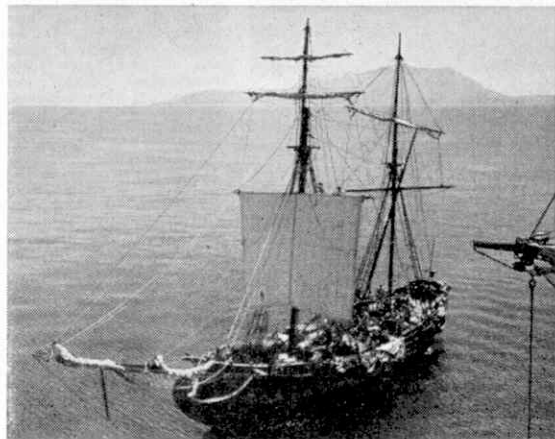

The pirate ship lying off the island. The illustrations to this article are reproduced by courtesy of Warner Bros.

Railway Notes

By R. A. H. Weight

New Locomotive and Rolling Stock Plans

I recently received official details of considerable interest regarding this year's plans for new construction.

Crews is to build one prototype class 8 4-6-2 express engine No. 71000 to a new design, and 10 more Britannia type class 7 Pacifics numbered 70045-54, while continuing with the 40 heavy freight 2-10-0s numbered up to 92039. There are to be 25 class 5 4-6-0s, Nos. 73050-74 from Derby, and five more of the class 4 variety having the same wheel arrangement for construction at Swindon numbered 75025-9. Of 2-6-0s, 10 more are on order at Doncaster in class 4, to be numbered 76035-44; 20 class 3 in hand at Swindon are Nos. 77000-19 and 33 class 2 building at Darlington are Nos. 78012-44.

Brighton Works are to continue with class 4 2-6-4Ts up to 80098, making 22 in the present order; while five are to come from Derby, ordered some time ago and numbered 80054-8. They will be followed by 10 to be put in hand at Doncaster, carrying numbers 80106-15. Another 15 class 3 2-6-2Ts, Nos. 82020-34,

and other non-passenger vehicles included under the heading of coaching stock, and 53,000 freight wagons.

News from the Western Region

New class 9 2-10-0s numbered 92000-4 are allocated to 86A, Newport (Mon.); others have arrived in the Western Region. No. 9490, 0-6-0T, has been completed by the Yorkshire Engine Co. Ltd. Among withdrawn tank engines are the last that came from the old Brecon and Merthyr, Nos. 435-6, 0-6-2; and from the Clebury Mortimer and Ditton Priors, No. 29, 0-6-0; and from the Llanelly and Mynydd Mawr, No. 359 *Hilda*.

British Railways' engine No. 1 is condemned. This was an 0-4-0 saddle tank named *Hercules*, used as a service locomotive and previously in service at a S. Wales factory.

No. 5572 was the first reported 2-6-2T fitted for pull-and-push working in S. Wales where, on various duties, B.R. class 3 2-6-2Ts, numbered 82000-9, and standard 4-6-0 tender engines have been noted.

The Swiss gas turbine locomotive No. 18000 returned in March to the early morning working from Paddington to Bristol and back, followed by a quick return trip from London to Swindon in the afternoon. No. 1000 *County of Middlesex* was engaged during January on test runs with dynamometer car and other apparatus between Reading and Stoke Gifford Yard, hauling

lengthy special empty coach trains, though not of such enormous weight as the maximum tackled successfully by *King Edward VII*.

Enterprising runs were recorded by Mr. D. S. Barrie on the nine-coach *Pembroke Coast Express* behind Castle 4-6-0 No. 5051 *Earl Bathurst*, when a good many delays beset the driver. Coming up from Newport, there were three signal stops, plus three other checks of additional character, yet the arrival at Paddington on a timing allowing some margin was only a minute late; the net time for 133½ miles was 144 min. Between signal stops at Hullavington and Reading, 62½ m.p.h. was averaged for nearly 58 miles. Westbound there was a late start from Paddington owing to exceptional circumstances, then five extra slacks for signals or repair work,

nevertheless 5 min. were gained on the schedule to Newport, equalling a net unchecked run in 137 min.

A splendid recovery effort on the fast 3.30 p.m. Paddington-Plymouth express was recorded under wintry conditions. Starting 15 min. late, the 142½ miles to Taunton were covered in 137 min., regaining 11 min. There were 11 vehicles, 370 tons gross, to Heywood Junction, Westbury, where a slip carriage was detached as on the *Cornish Riviera* which I travelled by and reported recently. The locomotive provided and manned by Old Oak shed was Britannia 4-6-2 No. 70018, appropriately named *Flying Dutchman*.

Enlargement and modernisation of an electric power plant at Portishead, Somerset, has led to the town, situated at the end of a branch line from Bristol and handling considerable passenger and freight traffic, receiving a fine new station of unusual and imposing design, with a constructional blend of local limestone and concrete. A roof canopy covers the whole of the 600 ft. island platform.

The 3¼-mile branch from Kidlington to Blenheim

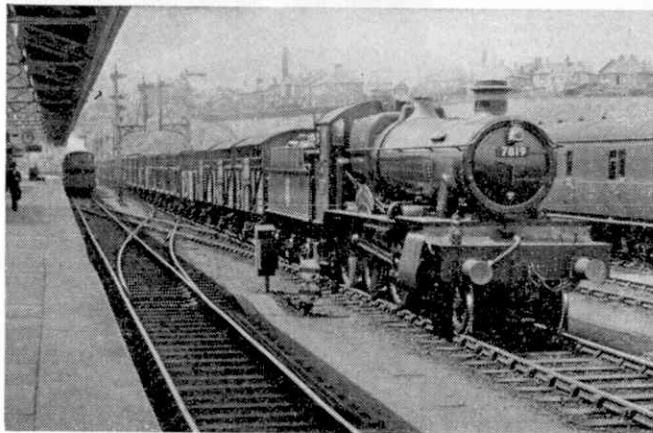

A northbound freight train of the Western Region passing Pontypool Road. The engine is 4-6-0 No. 7819 Hinton Manor. Photograph by N. Ewart Mitchell.

will be constructed at Swindon, also 10 W.R. type light 0-6-0Ts, Nos. 1650-9, while 30 heavy pannier tanks are to come from contractors, carrying numbers 3400-9, 9490-9 and 8440-9. There is one more L.M.R. 0-4-0T to come from Horwich, No. 47009, making 237 steam locomotives in all.

With diesel-electric propulsion the S.R. main line 2,000 h.p. locomotive No. 10203 was completing at Brighton at time of writing, and 54 0-6-0 shunting engines ordered from Derby and Darlington will carry numbers 13040-59, 13076-96 and 13127-39. There are also to be five small 0-6-0 and 3 0-4-0 diesel mechanical shunters, numbered respectively 11111-15, 11500-2, and six diesel-hydraulic 0-6-0s, Nos. 11702-7, built by contractors.

There will be seven large Co-Co electric main line locomotives for the Sheffield-Manchester service, taking the numbers up to 27006. The first, No. 27000, has been on trial. It is 59 ft. long, weight in working order 102 tons, capable of 90 m.p.h. speeds.

Divided among various railway and contractors' works are orders for 1,820 passenger coaches, 930 vans

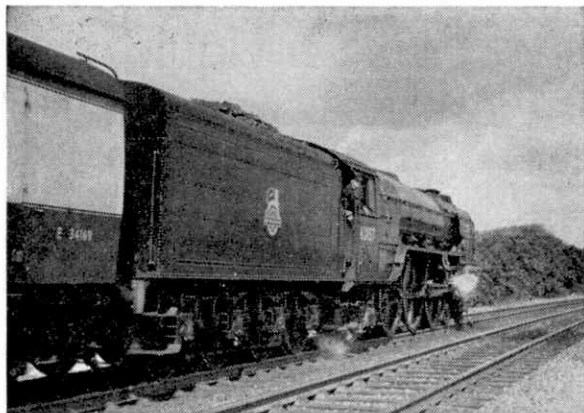

An unusual shot of Class A1 4-6-2 locomotive No. 60157 Great Eastern heading the down Flying Scotsman towards Peascliffe tunnel. Photograph by R. E. Vincent.

and Woodstock has been closed. Other stations, including the main one at Oxford, are not very far away. The last trips were operated by motor-fitted 0-4-2T No. 1420, with two trailer coaches for some runs to and from Oxford.

E. and N.E. Locomotive Notes

Allocation of new engines includes Nos. 80077-9, class 4 2-6-4T's, to 33A, Plaistow; 78012-5, class 2 2-6-0's, to 51F, West Auckland; 77000-1 and 77003, built at Swindon, to 51A, Darlington; and diesel-electric shunters Nos. 13075-81 to 53A, Hull, Dairycoats. Several of the B.R. 2-6-4T's have moved from Plaistow to Tilbury; five 4-4-2 former Tilbury line tanks were transferred to Stratford for local working from Shenfield to Southend (Victoria) and Southminster. L.M.S. type 2-6-4T's numbered 42328, 42374, went from Plaistow to Neasden; the second of these in March was working main line empty trains in and out of King's Cross. Neasden shed is part of the King's Cross district.

A3 No. 60055 *Woolwinder*, which is one of the original Gresley Pacifics reboilered, made a remarkable number of 312-mile daily journeys from Doncaster to King's Cross and back in the early part of this year, going south at 10.13 a.m. without stop on the York and Hull express and usually returning from London at 3.50 p.m. A sister engine, No. 60067 *Ladas*, meanwhile was often hauling the N.E.R. portion of the London businessmen's express from Doncaster to Newcastle and back, with very fast travel south of Darlington.

E4 2-4-0 engines of the now rather unique type formerly known as the Great Eastern Intermediate still flourish in the Cambridge area, and work across to Colchester and elsewhere. On one afternoon seven different

L.M.R. diesel-electric locomotive No. 10000, now on Southern Region duties, passes Eastleigh on the Royal Wessex. Photograph by Dr. G. D. Parkes.

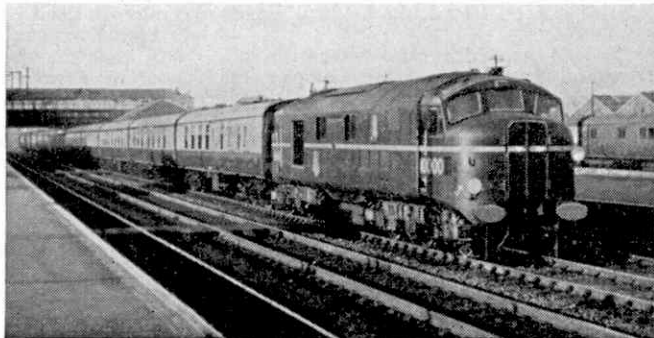

ones were noted in steam. There are 18 still stationed in East Anglian country districts, numbered 62780-97.

D16/3 rebuilt Claud Hamilton 4-4-0's are on King's Cross trains sometimes, among other duties from Cambridge. They and the rebuilt ex-G.E.R. 4-6-0's continue to render considerable service in the Eastern counties. S1 0-8-4T's, Nos. 69903-4 were lately allocated to Immingham depot; the other four moved from Mexboro' to Doncaster, then 69903 was withdrawn.

All ex-L.N.E.R. Pacific locomotives go to Doncaster Works for overhaul or heavy repair, together with representatives of a number of other large classes. Among the 50 or so in hand there on a recent typical day were the following: Pacifics; 2 A1, 2 A2, 5 A3 and 3 A4; 4 V2 2-6-2's; some B1 and B17 4-6-0's; 2-6-0's K1 and K3, and Ivatt L.M.R. type; with former G.N.R. goods and tank engines.

Southern Brevities

During February three Merchant Navy Pacifics were transferred to Bournemouth. They were No. 35008 *Orient Line*, from Salisbury; and Nos. 35011-2, *General Steam Navigation* and *United States Line*, from Nine Elms. No. 35022, *Holland America Line* left Rugby Testing Plant. No. 31780, class L4-4-0 was then still painted malachite green. S.R. diesel-electric No. 10202 had a trial spell hauling the *Golden Arrow* and *Night Ferry* Victoria-Kent coast boat trains; No. 10001 made some test runs from Brighton, including one with special expresses to New Cross Gate and back. The smaller main line locomotive No. 10800 also was out on trial, having been in Brighton Works for a considerable time before returning to some of the Oxted line duties.

Diesel Train Extensions, Eire and Queensland

As in Northern Ireland, there has been much development of light diesel train working throughout Eire. Six main line sets, consisting of twin railcars with intermediate coach and buffet car, operate between Dublin, Cork, Cobh, Waterford, etc., while a number of others provide suitably local and intermediate country services, as there are usually no great crowds to cater for.

In the Australian State of Queensland diesel-electric locomotives have effected considerable economies in operating, though their initial cost is high, as speed of both freight and passenger trains have increased and they can be used intensively.

Flour Pumped Like a Liquid

Road Tankers for Bulk Delivery

HAVE you ever thought of flour as a liquid? It seems strange that such a question can be asked of what is after all a solid in a fine stage of division. Yet flour can indeed be pumped by compressed air along pipes of comparative narrow bore, and it does not travel along the pipes like dust blown before a strong wind, but moves in a steady flow just like a viscous liquid.

Spillers Ltd., the well-known flour millers, became greatly interested in this way of moving flour, and thought it might be applied to loading and delivery. The result of this interest is seen in the illustration on this page, which shows a Leyland road flour tanker. The first Leyland vehicle to be fitted was an Octopus. Its three tanks can carry a load of $8\frac{1}{2}$ tons of flour, and by attaching a trailer, on which are two further containers, the total load has been raised to $15\frac{1}{2}$ tons, which is the equivalent of 248 ten-stone bags of flour. Later the Octopus was joined in this service by a Leyland Hippo and it is this vehicle that is seen in our picture. The containers and discharge equipment for both tankers were supplied by H. Tollemache and Co. Ltd., London, and the installation on the chassis has been carried out by Isles Ltd., Leyland agents at Leeds.

To load the vehicle, flour is drawn from a bin and travels along a conveyor for delivery through manholes at the tops of the tanks. A tanker or trailer can take on its full load in less than ten minutes.

A Reavel rotary air compressor is used for unloading. It is mounted behind the cab—part of it can be seen in our illustration—and is driven from the 5-speed gear-box of the Leyland. When the compressor is started valves are opened to the tanks to build up pressure in them, and when the necessary pressure has been reached the discharge valve is opened and

the flour passes along the pipe-line into the storage bin in the bakery. The pipeline is in two sections. One is permanent, leading to the bin, and the other is a flexible hose connection carried on the tanker. At Spillers' own factory flour is pumped up to a height of 40 ft., and in an experiment a height of 100 ft. was reached without any difficulty.

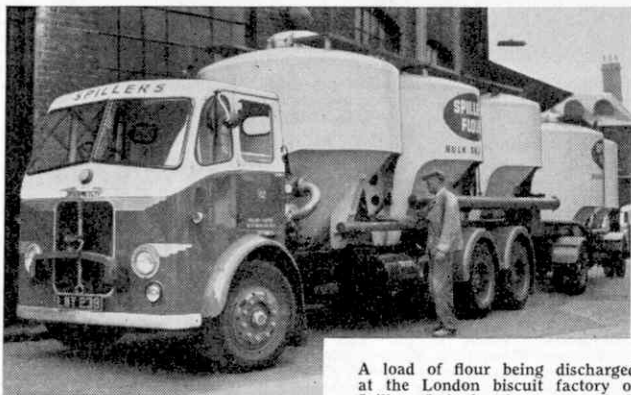

A load of flour being discharged at the London biscuit factory of Spillers Ltd. by the new method.

The tanks are separate and are strongly constructed to withstand air pressure. A noteworthy feature is the shape of the bases. These have been made conical partly to make easy the proper mixing of the air and flour, and partly also to give the correct fall to the discharge points at the bases of the tanks. The flour does not come into contact with metal, for the tanks are lined with Lithcote.

Special precautions are taken to make sure that the air used for discharging the flour is perfectly clean, without any trace of dust or dirt. In the compressor a special lubricating oil is used that has no smell or taste and cannot have any ill effects, and there is also an oil separator to prevent oil from passing over with the air.

This system of carrying flour from the mill to the vehicle is the last word in cleanliness and efficiency. Besides being easier and quicker than older methods, it has the advantage that the flour is not touched by hand or exposed in any way until it enters the dough mixture.



A MAJOR drawback with helicopters has always been that their rotor has to provide both lift and thrust, replacing the wings and propeller of an orthodox fixed-wing aeroplane. It enables them to take off and land vertically, but is very inefficient in forward flight, with the result that few helicopters cruise at more than 80-90 m.p.h.

Obviously, what is needed is something that will take off vertically like a helicopter, but have the cruising speed of a fixed-wing aeroplane; and the British Fairey Aviation Company produced the first aircraft of this type in 1947. Named the Gyrodyne, it had an engine-driven rotor to provide lift and a propeller to provide thrust in forward flight. Powered by a 500 h.p. Alvis Leonides engine it set up a world helicopter speed record of 124.3 m.p.h. which still stands as a British record.

American designers were quick to recognise the possibilities of the Gyrodyne's unique layout, and began to plan a whole series of "convertiplanes" — so called because they convert from a helicopter to a fixed-wing aircraft after take-off. First to be completed is the McDonnell XV-1, illustrated above by courtesy of the McDonnell Aircraft Corporation, U.S.A.

Despite its unusual appearance, the XV-1 promises to revolutionise U.S. helicopter design. It is powered by a Continental piston-engine, which, for take-off, drives compressed air through the hollow rotor blades to pressure-jet units at the rotor tips. The air is mixed with fuel in the pressure-jets, burned, and the resulting thrust turns the rotor.

After reaching a safe height, the engine power is switched to drive the pusher propeller. The rotor continues to turn automatically in the airflow, keeping its drag low; but virtually all lift is provided by the fixed wings, which need be only half the size of the wings of a comparable fixed-wing aeroplane as they do not have to provide lift for take-off or landing.

Similarly, the rotor can be much smaller than that of an orthodox helicopter, because of the high efficiency of the pressure-jets. So, far from being penalised by having both rotor and fixed wings, the XV-1 actually scores on all counts. The

result will almost certainly be unusually good performance for a rotating wing aircraft; but we shall not know for a few more weeks, as it is completing a long programme of ground and wind

tunnel testing before making its first flight.

The XV-1 is about 30 ft. long, 10 ft. high and spans 26 ft. It has been designed for a variety of duties, including observation, reconnaissance, artillery spotting and casualty evacuation, carrying three passengers or two stretcher patients and an attendant as well as the pilot. If it fulfils its expectations, McDonnell will almost certainly start work on much larger aircraft of the same type for both military and civil use.

Meanwhile, Faireys are testing a pressure-jet version of the Gyrodyne, and other convertiplanes are on the way, some working on entirely different principles. So there looks like being plenty of good healthy competition in this newest and very promising line of aviation development.

America's First Convertiplane

By John W. R. Taylor

Among the Model-Builders

By "Spanner"

An Unusual Quick Return Mechanism

Machine tools of all kinds make attractive subjects for model-builders with good stocks of parts at their disposal, as most of them incorporate interesting mechanisms. Among these are devices for speeding up the return or non-cutting stroke. Several quick return arrangements have been described in the *M.M.*, but the mechanism I am describing this month is specially interesting as it is operated by a Crank and an ingenious arrangement of pivoted levers that can be seen in the illustration below.

The Crank 1 is fixed on the driving shaft, and to it is pivoted on a lock-nutted bolt a $3\frac{1}{2}$ " Strip 2. The other end of this Strip is lock-nutted to a $2\frac{1}{2}$ " Strip 3 and a 3" Strip 4. A $\frac{3}{8}$ " Bolt is passed through the Strip 3 and is gripped in the boss of a Slide Piece, which is slipped over a $5\frac{1}{2}$ " Strip supported by Angle Brackets. The Strip 4 is bolted to a Crank that pivots freely on a $\frac{1}{2}$ " Bolt 5.

Assuming that the Crank 1 is rotating anti-clockwise, when it is in the position shown in Fig. 1 the Slide Piece moves slowly to the left, to make the cutting stroke. As the Crank turns towards the Bolt 5 the Slide Piece returns more rapidly. The closer the end of Crank 1 is to the Bolt 5, the more rapid is the movement of the Slide Piece.

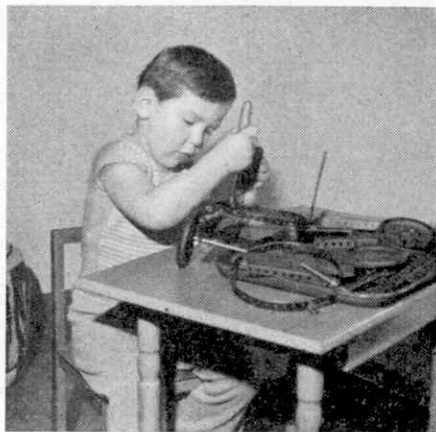

Is he the youngest reader of the "M.M."? Denis Philippe Donner, Bienne, Switzerland, is only four years of age, but he is already a Meccano enthusiast and takes a keen interest in the "M.M."

A Meccano Front-Wheel Drive Mechanism

The introduction of the Dinky Toys Army Covered Wagon has prompted many enthusiasts to make Meccano models of this and other army vehicles and several have written to tell me of the difficulties they have found in reproducing the front-wheel drive mechanisms fitted to most up-to-date army vehicles. Actually it is quite easy to assemble an efficient front-wheel drive mechanism from standard parts, and the arrangement shown in Fig. 2 is quite satisfactory.

The front axle consists of two built-up strips, each made from two $5\frac{1}{2}$ " Strips overlapped nine holes. The strips are spaced apart by three Washers on each of the Bolts that fixes them to the front springs. The road wheels are mounted quite freely on short Rods, each of which is fixed in a Coupling that carries two 1" Rods. A $\frac{3}{4}$ " Pinion 4 is free to turn on the upper 1" Rod, but it is held in place by a Collar, and the

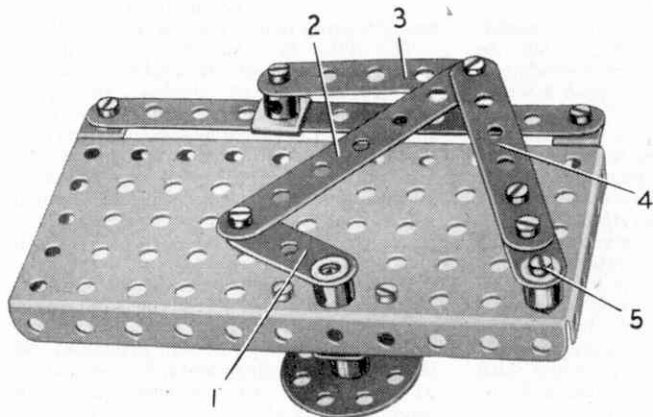

Fig. 1. A quick return mechanism of unusual design, suitable for use in planing machines and models of other machine tools.

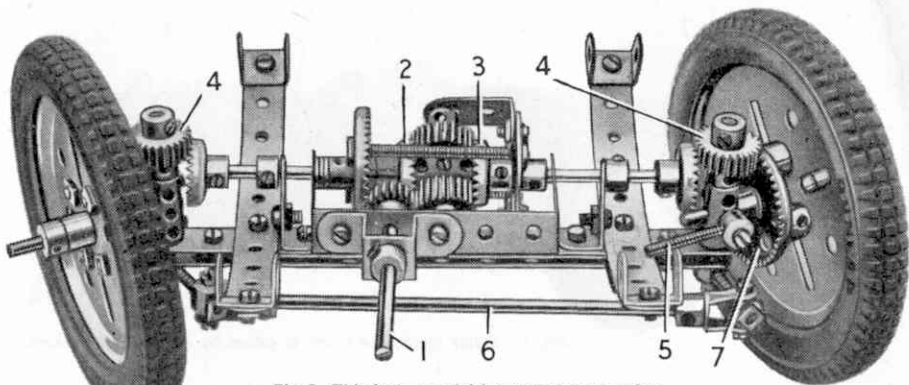

Fig. 2. This front-wheel drive arrangement makes an interesting mechanism for models based on army wagons and vehicles designed for work over rough country.

lower Rod is supported in the end holes of the front axle and is also kept in position by a Collar. A $1\frac{1}{2}$ " Contrate 7, spaced from each road wheel by Collars on $\frac{1}{2}$ " Bolts, is driven by the Pinion 4. A 1" Screwed Rod threaded into the Collar on each of the lower 1" Rods is provided with a Swivel Bearing. The Swivel Bearings are connected by a Rod 6. Another 1" Screwed Rod 5 is fixed in a Collar attached by a $\frac{3}{8}$ " Bolt to one of the Couplings. This Screwed Rod is connected by suitable links to the steering gear.

The driving shaft to the differential is a Rod 1 supported in a Double Bent Strip and a $2\frac{1}{2}$ " x 1" Double Angle Strip. A $\frac{1}{2}$ " Pinion on Rod 1 drives a $1\frac{1}{2}$ " Contrate that is connected to a Bush Wheel by 2" Screwed Rods. Two 1 " x $\frac{1}{2}$ " Angle Brackets are bolted to the Bush Wheel, and in them is mounted a $1\frac{1}{2}$ " Rod fitted at its centre with a Coupling. Two $\frac{3}{4}$ " Pinions are free to turn on the $1\frac{1}{2}$ " Rod.

The differential half shafts are supported in 1 " x $\frac{1}{2}$ " Angle Brackets bolted to the front axle, and are passed through the $1\frac{1}{2}$ " Contrate and the Bush Wheel into the centre Coupling of the differential. The $\frac{3}{4}$ " Contrates 2 and 3 on the half shafts are meshed with the $\frac{3}{4}$ " Pinions.

A $\frac{3}{4}$ " Contrate fixed to the outer end of each half shaft is arranged so that it drives one of the Pinions 4.

Non-Slip Built-Up Pulley

Master J. Basham, Romford, tells me that he has found the simple built-up pulley shown in Fig. 3 useful for operating the traversing Cord of simple hammerhead cranes as it prevents cord slip. The pulley is very simple and consists of two 1" fixed Pulleys fitted with Motor Tyres and pressed tightly one on each side of a 1" loose Pulley fitted with a Rubber Ring.



Fig. 3. Master J. Basham, Romford, is the designer of this non-slip pulley arrangement for operating the traversing Cords of model cranes.

"SIMPLICITY" MODEL-BUILDING CONTEST

Here is a contest in which owners of even the smallest Meccano Outfits can compete on level terms with those more fortunate possessors of the largest sets, and we hope that every Meccano boy who reads this announcement will decide to send in an entry. Prizes will be awarded to model-builders who succeed in constructing the most ingenious and realistic models from the smallest number of parts. A competitor may choose any subject he likes for his model, and the more unusual and

interesting this is the better the chance of winning a prize, provided that the model is kept quite simple.

When the model is completed the competitor should obtain either a photograph or a good drawing of it. He should then write his age, name and address on the back of the illustration and send it to "Simplicity Model-Building Contest, Meccano Ltd., Binns Road, Liverpool 13." The actual model must not be sent.

The competition will be divided into two Sections: A, for readers under 14 years of age, and B, for readers over 14 years of age. The closing date is July 31st next.

The Prizes to be awarded in each Section are as follows. First, Cheque for £3/3/-. Second, Cheque for £2/2/-. Third, Cheque for £1/1/-. There will be also Ten Prizes each of 10/- and Ten Prizes each of 5/-.

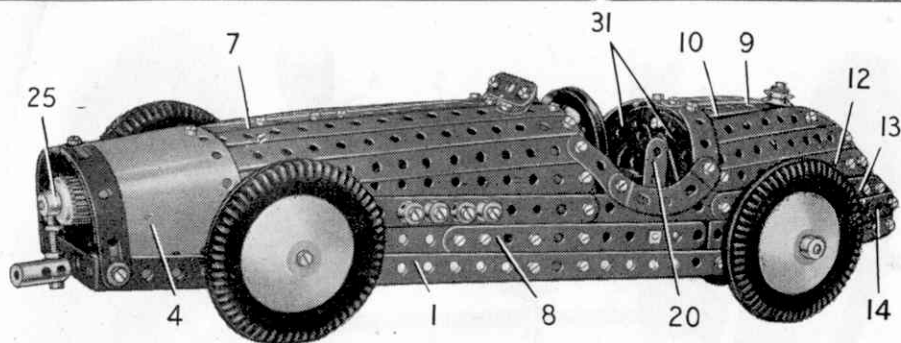

Fig. 1. A fine racing car which is driven by a rubber motor unit.

New Meccano Model

Racing Car Driven by Rubber Motor

MOST model-builders will be familiar with the rubber "motor" used to drive the propellers of model aeroplanes, but I wonder how many of them have ever tried using this form of power unit to drive a Meccano car. It is quite possible to do so, provided that the car is specially designed for this method of propulsion, and making such a model provides a pleasant change from the ordinary methods of construction. I have therefore chosen a car of this kind as the subject of a new model. This takes the form of a racing car, and is shown in Fig. 1.

I advise you to commence construction of the model by assembling the lower members of the body represented by the strips 1, each of which is made from a $12\frac{1}{2}$ " and a $5\frac{1}{2}$ " Strip bolted together. They are connected by two $2\frac{1}{2}$ " x $\frac{1}{2}$ " Double Angle Strips 2 at the front, by two $3\frac{1}{2}$ " x $\frac{1}{2}$ " Double Angle Strips 3 at the centre and by a Double Bracket at the tail.

You can form the body from Strips of various sizes attached to three supporting hoops fixed to the strips 1. For the front curve a $5\frac{1}{2}$ " x $2\frac{1}{2}$ " Flexible Plate 4 and bolt this

direct to the strips 1 by its front corners. Then attach the rear corners of the Plate to the strips 1 by means of Fishplates. To form the centre supporting hoop take two $5\frac{1}{2}$ " x $1\frac{1}{2}$ " Flexible Plates 5, overlap them seven holes, and attach them to the strips 1. For the third hoop two curved $4\frac{1}{2}$ " Strips 6 are used, and these also are fixed to the strips 1.

Now fill in the bonnet with ten $7\frac{1}{2}$ " Strips and a built-up strip 7 made from a $5\frac{1}{2}$ " Strip and a 2" Slotted Strip. Bolt the strip 7 to the Plates 4 and 5, and fix the $7\frac{1}{2}$ " Strips to the Plates 5. Overlap the front ends of the $7\frac{1}{2}$ " Strips slightly as shown in Fig. 2, and then clamp them between the Plate 4

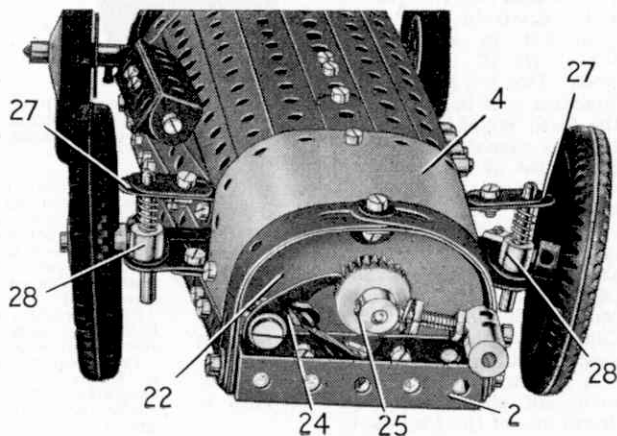

Fig. 2. The front of the car showing the ratchet motor winding device.

and two Formed Slotted Strips bolted inside the rear edge of the Plate. You should complete the bonnet with a strip 8 on each side, made from a $5\frac{1}{2}$ " Strip extended by a $2\frac{1}{2}$ " Strip. Connect the front ends of the strips 8 to the strips 1 by Fishplates.

To assemble the tail bolt a slightly curved strip 9 between the Strips 6 and the Double Bracket that connects the strips 1. To make the strip 9 overlap a $5\frac{1}{2}$ " and a $2\frac{1}{2}$ " Strip two holes. Now fill in each side of the tail with a 3" Strip 10, a $3\frac{1}{2}$ " and a $4\frac{1}{2}$ " Strip, and connect them with a $1\frac{1}{2}$ " Strip 11, a second $4\frac{1}{2}$ " Strip 12 joined to the Strip 11 by a 1" Corner Bracket, and a $5\frac{1}{2}$ " Strip 13 connected to Strip 12 by a 1" Corner Bracket. You can now complete the sides of the tail using $4\frac{1}{2}$ " Strips 14, which have to be attached by Fishplates at each end to

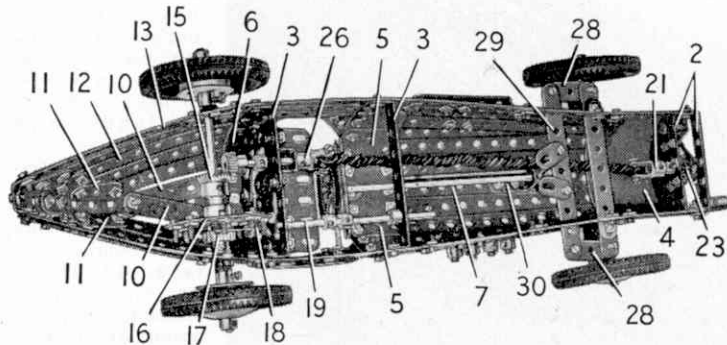

Fig. 3. An underneath view of the racing car, showing the arrangement of the rubber Driving Bands.

the strips 1 and the Strips 13.

The sides of the driver's cockpit are formed by $1\frac{1}{2}$ " and 2" Strips and $2\frac{1}{2}$ " Stepped Curved Strips, arranged as shown. Before you bolt the Strips forming the tail in position don't forget to curve them slightly.

Now we come to the rear axle. This is a $6\frac{1}{2}$ " Rod and it is supported in the centre holes of $1\frac{1}{2}$ " Strips bolted between the strips 1 and the Strips 13. The drive to the axle is transmitted through a simple free wheel device, made by connecting a $\frac{3}{4}$ " Contrate 15 and a Face Plate 16 by means of a Socket Coupling. Make sure that this assembly is free to turn on the rear axle. Now fix a Ratchet Wheel 17 on the axle and space it from the Face Plate by three Washers. Take a Pawl without boss 18 and pivot it on a $\frac{3}{8}$ " Bolt attached to the Face Plate by two nuts. Space the Pawl on the Bolt by Washers, and arrange for it to be held against the teeth of the Ratchet Wheel by means of a

$2\frac{1}{2}$ " Driving Band looped round a $\frac{3}{8}$ " Bolt in the Face Plate. The rear wheels are 2" Pulleys with Motor Tyres, fitted each side with a Conical Disc held in place by a Collar.

The chassis is fitted with a simple brake easily made by fixing $\frac{3}{8}$ " Bolts in the outer holes of the Face Plate. Now mount a 4" Rod 19 in the Double Angle Strips 3 so that by operating a lever 20 you can move it to engage these Bolts. This lever is a $2\frac{1}{2}$ " Strip lock-nutted to one of the strips 8, and it carries a $\frac{1}{2}$ " Bolt that engages between two Collars on the Rod 19.

Now you can fit the rubber bands that provide the power unit. Take two 20" Driving Bands and loop them at the front round a $\frac{3}{4}$ " Bolt held by two nuts in a small Fork Piece 21. The Fork Piece is fixed on a $1\frac{1}{2}$ " Rod, which is passed through the centre hole of a Semi-Circular Plate 22. This

is connected to the Plate 4 by an Angle Bracket, and to one of the Double Angle Strips 2 by Fishplates. A $\frac{3}{4}$ " Pinion 23 is used to hold the $1\frac{1}{2}$ " Rod in the Semi-Circular Plate. The next job is to arrange a Pawl 24 to engage the Pinion and allow it to turn in one direction only. The Pawl should be mounted on a Pivot Bolt held by its nuts in the Semi-Circular Plate, and you should loop a $2\frac{1}{2}$ " Driving Band between a $\frac{1}{2}$ " Bolt and the Pawl to keep it against the teeth of the Pinion.

Now make a winding handle from a $1\frac{1}{2}$ " Bolt screwed through a Threaded Coupling into the boss of a $\frac{3}{4}$ " Contrate 25. Use nuts to fix the Threaded Coupling and the Contrate tightly on the Bolt.

All that remains now is to loop the other ends of the 20" Driving Bands round a $\frac{3}{4}$ " Bolt held by nuts in the small Fork Piece 26. Fix this Fork Piece on a 2" Rod and support the Rod in a $1\frac{1}{2}$ " Flat Girder bolted to one of the Double Angle Strips 3 and in a Double Bent Strip. Arrange a $\frac{1}{2}$ " Pinion on the 2" (Continued on page 260)

HORNBY RAILWAY COMPANY

By the Secretary

Hornby-Dublo Diamond Crossings

I HAVE some good news for Hornby-Dublo enthusiasts this month. For some time I have been receiving enquiries from enthusiasts about the Diamond Crossings that are shown in our price lists as *Available later*. Supplies of these are coming along now, and if you have not yet seen the Crossings in dealers' shops you will do so very shortly.

The purpose of a diamond crossing is to enable one track to cross another on the level. This means that each track must, in effect, be cut at the appropriate places, and yet provide a

continuous flangeway for Hornby-Dublo wheels, so that trains will pass over it with a minimum of disturbance. The centre rail sections on each arm of the Crossing stop short at the centre unit, and wiring connections underneath ensure continuity of supply for each route.

It may be wondered why there are two types of Crossing, one described as Right Hand and the other as Left Hand. *How can you have a Right Hand Crossing?*

Several Hornby-Dublo owners have asked this indignantly. Well, the answer is that you can, in Hornby-Dublo, and the explanation is really simple.

Most of the uses to which the Crossings can be put are in connection with Points. This is so in actual practice too, as crossings form an essential part of most junction layouts, such as Gretna Junction, illustrated on these pages. Now, the track standards of

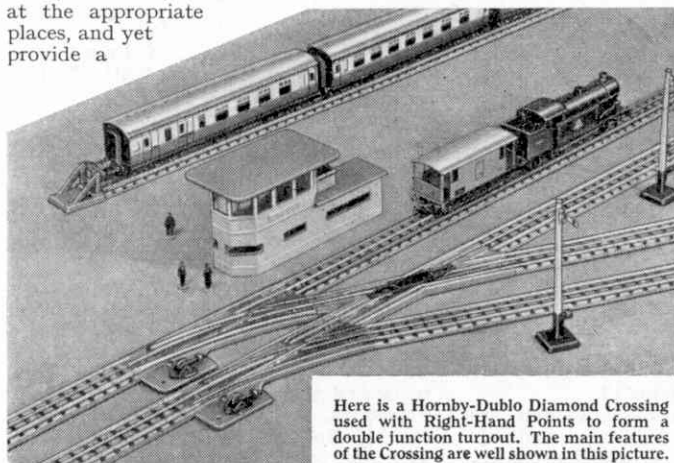

Here is a Hornby-Dublo Diamond Crossing used with Right-Hand Points to form a double junction turnout. The main features of the Crossing are well shown in this picture.

continuous and safe path for the wheels of the trains that must use it day in and day out. What a real crossing looks like can be seen in the upper illustration on the next page.

The rails of the Hornby-Dublo Diamond Crossings are ingeniously assembled on a die-cast base that forms a splendid foundation for the whole unit. The fishplates and centre rail connecting clips are of course the normal fittings, so that the Crossings join up to adjacent sections of Hornby-Dublo track without difficulty.

To prevent the two intersecting routes from conflicting with one another from the electrical point of view, the centre unit of the Crossing—the actual diamond that gives the component its name—is a plastic moulding that forms the running rail

the Hornby-Dublo system make it necessary for one route of the Crossing to correspond in length with a Straight Half Rail. The other route, which crosses it diagonally, has to be slightly longer, as it must itself meet correctly the curved arm of Points laid in the adjacent track at the standard double track distance apart.

This means that one pattern of Crossing would not fit in with both types of Points. Therefore two types of Crossings are necessary; simple, isn't it?

The way in which the Crossings fit in will be clear immediately you start to use them. And in order to help you tell one Crossing from the other the die-cast base bears underneath the wording *Right Hand* or *Left Hand*, as the case may be. Again, in order to distinguish which track is

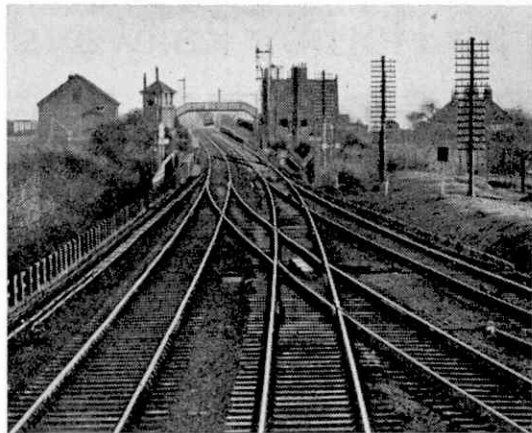

The double track turnout at Gretna Junction, Scottish Region, with the diamond crossing prominent in the foreground. British Railways Official Photograph.

which from the running point of view, the base of the unit bears the words *Main Line* in the "four-foot way" at each end of the shorter arms of the Crossing.

Look at the Hornby-Dublo illustrations on this and the previous page. In one you can see quite well how the Crossing fits in with two sets of Points to form what Hornby-Dublo owners frequently asked for—a double junction turnout. The two main tracks are of course the standard distance apart, and it will quickly be realised why the diagonal track on the Crossing has to be longer than the other.

The formation of a double junction is by no means the only purpose to which the Hornby-Dublo Diamond Crossing can be put. On a double track layout it may be necessary to take a connection by means of Points off the outer track and to bring this across the inner main line to lead to a siding. Again, one track may be

Duchess of Montrose at the head of a Hornby-Dublo express negotiating the Crossing of a double junction turnout.

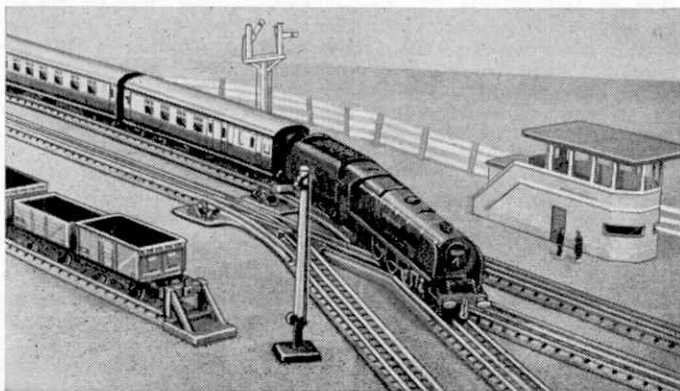

required to cross several others parallel to one another. In that case a succession of Crossings can be used and the design is such that the tracks that are crossed are maintained at the correct distance apart, while the rail joints of these adjacent tracks can be made to come level with one another, so that the sidings can all be finished off by a level row of Buffer Stops, not in the straggling, uneven manner that is sometimes seen.

Another use for the Diamond Crossing is in the provision of a siding, in a trailing direction, from the inner line of a double track oval that has been formed by Large Radius and Standard 15 inch Radius Curves. The lead-in to the siding will have to cross the outer main line by a Left Hand Crossing and careful and skilful working will be necessary to make sure that a train backing across to the siding is not run into by another travelling on the main line. The signalling arrangements should be arranged to give protection to trains when such operations are being carried out, as in real practice.

Not only can we have trailing sidings, but a direct approach into a facing siding can be arranged with a Right Hand Crossing. Again, careful working will be the rule in order to avoid collisions.

The eager Hornby-Dublo owner will be able to discover other interesting track formations incorporating the Diamond Crossings, and endless fun can be had in experiments of this kind.

More B.R. Trains for Hornby Railways!

THE process of changing the Train Sets and components of the Hornby System into British Railways colours is proceeding steadily, and readers will be interested to hear of the further progress to be recorded this month.

Last month the Secretary told you about the new Nos. 20 and 21 Train Sets, these being the revised designations, in B.R. style, of the Sets long familiar as M0 Goods and M0 Passenger respectively. Moving up the Hornby scale, the next Sets requiring attention were the former 101 Tank Goods and Passenger Train Sets, and here pictured on these pages are their successors in B.R.

101 Tank, but it is now smartly turned out in the lined black livery that distinguishes the mixed traffic tank locomotives of today, with of course the B.R. lion and wheel on the side tanks.

It is a long time since the Hornby Train System included a black engine, but the truth and fine appearance of this one will make it a great favourite. The boiler bands are picked out in double red lines, while the side tanks and bunker are outlined in grey and red. The engine number appears on the bunker sides and a pleasing detail is the addition of the number on the smoke-box front, in accordance with B.R.

standard practice. Altogether this is a smart little engine for a

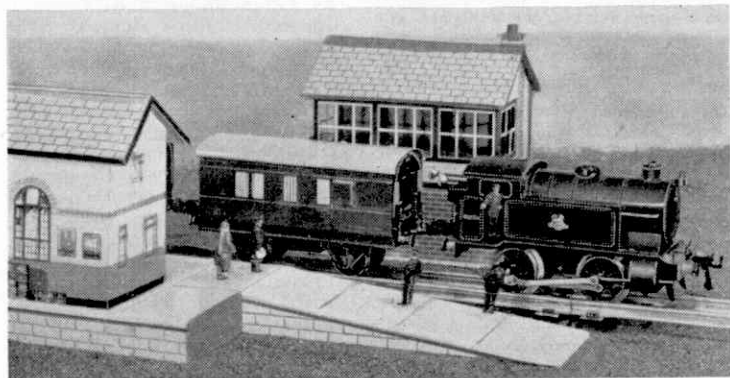

Suburban departure. A Hornby No. 40 Tank Locomotive in B.R. black livery is ready to leave the station with a train.

style, now known as the No. 40 Tank Goods Set and the No. 41 Tank Passenger Set respectively.

Let us look at the No. 40 Set first. The make-up of the Set is still the same, the train consisting of a Tank Locomotive, a standard open Wagon, Timber Wagon and a Tank Wagon. A point of view sometimes put forward in connection with this make-up is that for a goods train a Goods Brake Van should be included. It is felt, however, that it is better to leave the Set as it is, because its present composition as bought provides variety in stock, and in any case the Goods Brake Van is readily obtainable separately. As a rule the owner of one of these Sets does not lose much time in adding a Brake Van.

The engine, which is included in the No. 41 Passenger Train Set as well, is now known as Tank Locomotive No. 40. In design it is unchanged from the former

Wagon included in this Train Set is in B.R. grey, with the lettering details in white on the usual black background, and the other wagons follow standard Hornby practice.

Turning to Passenger Train Set No. 41, the make-up here is the same as that of the 101 Tank Passenger Train Set that it replaces. The engine we have already dealt with, but the No. 41 Coaches in their smart B.R. livery will attract interested attention. In the new tinprint design the flush-sided steel-panelled style of present-day stock has been followed with remarkably good results. Each of the Coaches includes two first class compartments, suitably marked, and two third class. All possible details have been included, and as the illustrations show the trains have a smart and clean appearance.

The Passenger Brake Van follows the general style of up-to-date luggage brakes.

multitude of jobs on a Hornby railway.

The No. 1

Like the other vehicles in the Set, it includes a realistic detail in the shape of the lamp brackets at each end. Thus whether a Coach or a Van runs at the end of the train, the tail lamp that is provided in the Set can be correctly displayed. This is a little point of railway working that is

One of the new Hornby No. 21 Passenger Trains in B.R. finish is passing the Signal Cabin. The engine and tender are dark green and the coaches red and cream.

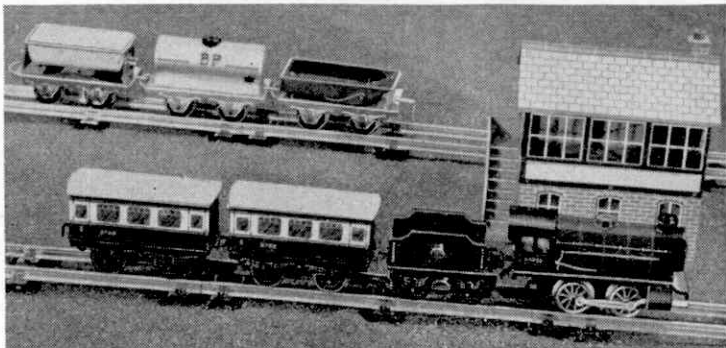

frequently missing from miniature rolling stock much more highly-priced.

Similar changes are to affect the 601 Goods and 501 Passenger Train Sets. These will become Goods Set No. 50 and Passenger Set No. 51 in their new B.R. style. Although the engines and tenders used in these Sets are of similar design they are coloured differently. Locomotive No. 50 of the Goods Set of course is

but the Flat Truck is in B.R. bauxite brown with white lettering, including the *XP* designation applied to brake-fitted vehicles. The Goods Brake Van is coloured similarly, and it retains the tail and side lamp brackets that help to make goods train

running on a Hornby railway so realistic.

In the rolling stock of the Passenger Train Set No. 51 there is an interesting departure from previous practice, for instead of compartment-type coaches we now have vehicles modelled to represent standard corridor stock. The smart appearance of the two Coaches and of the Passenger Brake Van in B.R. crimson and cream is very striking. The Brake Van of course represents the special vans

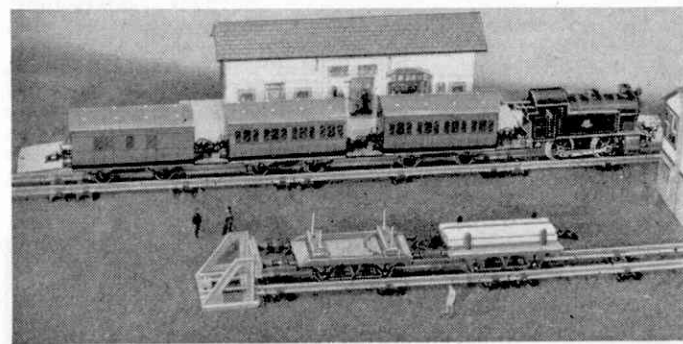

A realistic view of the new Hornby No. 41 Passenger Train alongside the Station platform. Engine and vehicles have a smart appearance in B.R. finish.

black with appropriate lining, just as are goods engines on British Railways; Locomotive No. 51 of the Passenger Set on the other hand is finished in the correct B.R. passenger green. Both engines look very smart in their new uniforms.

The Goods Set vehicles have been brought up to date. The open Wagon is the same as that in the No. 40 Goods Set,

of real practice that are painted to match the corridor trains in which they are intended to be run.

There are no pictures of these Trains yet, because they are not expected to be ready quite as soon as the others already mentioned. Still, you will all have been interested to know something about them. It is quite certain that many of you will eagerly await their appearance in the shops of your usual dealers.

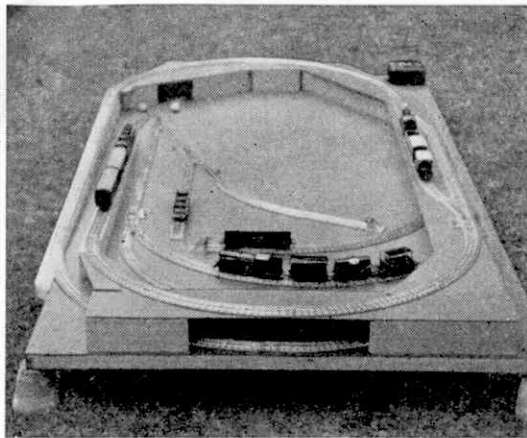

An end view of the two-level railway developed by Mr. C. Richardson, Surbiton, Surrey, that is described on this page.

THE first requirement in planning the Hornby-Dublo railway shown in the pictures on this page was that it should be capable of being stowed away, when not in use, behind an ordinary single bed. This settled the size of the board. But in spite of its more or less restricted size the engineer and owner of the system, Mr. C. Richardson, of Surbiton, Surrey, was keen to incorporate two-level working. He has just managed to do this, but the steepness of the gradients leading to the high-level part of the track, and the fact that parts of the grades are on curves, has involved various restrictions in the locomotives and rolling stock used, and in operations.

Normally, of course, gradients on curves are things to be avoided, but by careful choice of stock, by restriction of loads and by very thorough track work and skilful engine driving it has been made possible for the owner to enjoy successful running.

The fact that the baseboard is a fixture to which the tracks are permanently attached naturally helps matter in this direction.

The baseboard itself consists of hardboard one-eighth of an inch thick, supported by oak battens. The upper level is also hardboard, supported by stripwood. The whole construction has worked out very nicely, and an important point is that the total weight of the board and equipment is such that it can be carried upstairs for storage without much trouble.

The layout began with a single oval track. Then one of the curved ends was doubled, and sidings within the main oval were added. With the development of the upper-level track a further single line oval became available with a reasonable length of run. Isolating Switch Points are used

throughout, and with appropriate placing of insulating gaps this means that unless all Points for a particular run are set correctly the train is brought to a stand. This "safety-first"

feature is particularly valuable when Mr. Richardson's small son is in charge.

The covered way through which the lower track passes at each end is not boxed in entirely. This is a wise move because if any mishaps do occur on a miniature railway, they almost always happen when the train is in the most inaccessible position.

A Railway that Stows Away

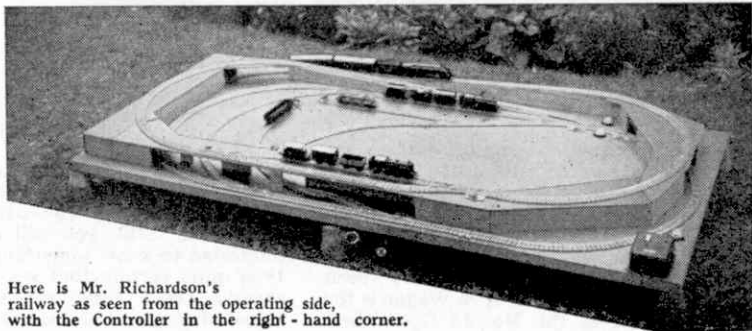

Here is Mr. Richardson's railway as seen from the operating side, with the Controller in the right-hand corner.



Club and Branch News



WITH THE SECRETARY

PHOTOGRAPHERS TO THE FORE!

Almost all the group photographs of Club or Branch members which I receive are the customary indoor pictures showing the members grouped together in the Club room, or running an Exhibition; and of course I am always glad to have them. The varied outdoor activities of the Summer sessions, however, do provide many opportunities of obtaining snapshots of a less formal kind, showing members in camp, on excursions or playing games. "Off duty" pictures of this kind are specially welcome at Headquarters. I hope that the amateur photographers among Club and Branch members will make the most of any chances that come their way to obtain such snapshots this Summer, and that secretaries will send the best along to me for possible reproduction on this page in future issues.

Such photographs are always of great interest to other Clubs and Branches, and their appearance in the *M.M.* is excellent publicity for the Club or Branch concerned.

MECCANO CLUBS RECENTLY AFFILIATED

WEST OF ENGLAND SCHOOL (EXETER) M.C.—Mr. R. Charlton, 17 St. David's Hill, Exeter.
SMITHFIELD (ABERDEEN) M.C.—Mr. G. Hart, 16 Lintmill Terrace, Northfield, Aberdeen.
TOWN THORNS SCHOOL (ESSENHALL) M.C.—Mr. J. A. Rogers, Town Thorns School, Essenhall, nr. Rugby.

BRANCH RECENTLY INCORPORATED

No. 550—NEWPORT (I.O.W.) CHURCH OF ENGLAND BOYS' SCHOOL—Mr. D. Cockshaw, Newport C.E. Boys' School, West Street, Newport, Isle of Wight.

CLUB NOTES

MILE END (PORTSMOUTH) M.C.—Dismantling of the large model trolley bus has been completed, and the parts are being scraped and repainted. The fourth Anniversary party, for which a cake was made by the mother of the Mile End H.R.C. Branch secretary, was greatly enjoyed.

During the evening the ceremony of laying the keel of the large model submarine to be built by the Club was performed. Table tennis tournaments and Dinky Toys layouts evenings have been held. Club roll: 52. *Secretary:* Mr. A. J. Nicholson, 213 Sultan Road, Buckland, Portsmouth.

HORNSEA M.C.—The recent programme has included Meccano model-building, games, film shows and a talk by the Leader on York and the East Riding. A table tennis competition gave rise to some exciting games. An old tradition of holding a party to celebrate the anniversary of the present Leader taking

over has been revived, and a very enjoyable evening was spent. The Leader has given a talk on the Club's history, in the course of which he recalled various outings and other aspects of his long association with the Club. Club roll: 16. *Secretary:* D. M. Stevenson, 29 Southgate Gardens, Hornsea, E. Yorks.

BRANCH NEWS

MILE END (PORTSMOUTH)—An Open Night is being held every two months. The Mile End M.C. have awarded the Branch a contract for the carriage of Meccano parts in connection with the building of a large model submarine. The model town has been enlarged, and plans are in hand for further developments. A competition was held for the best Hornby-Dublo layout utilising the equipment at the Branch's disposal, and the winning layout was constructed and operated at the first subsequent Track Night. New members will be welcomed. *Secretary:* J. C. Jeffery, 52a Elm Grove, Southsea, Portsmouth.

AVIARY (LEEDS)—A new member, Mr. Baldwin, gave a very helpful talk and demonstration on the construction of a Hornby-Dublo layout. Other interesting talks have been given, one by a member of the Police Division of the British Transport Commission who told the story of the Railway Police from the introduction of this force in the 1820s to the present day, and another by a locomotive driver who described his work and explained the differences between types of locomotives, signals, etc., and afterwards answered many questions. Members are now grouped into three teams for operating the Hornby Gauge 0 layout, each team in turn doing so for an entire evening. *Secretary:* L. Blakey, 21 Arley Street, Armley, Leeds 12.

KENTISH TOWN (LONDON)—Attendance has been well maintained, and members have been busy preparing for the second Annual Branch Exhibition, which it is hoped will attract new members. A cycling section is to be formed during the present session. *Secretary:* S. A. Kirby, 9 Busby Place, Kentish Town, London, N.W.5.



Members of the "Ladysmith Hotspurs", the excellent Exeter M.C. football team formed last Winter. Mr. M. C. Hodder, Leader of the Club, is at the extreme left.

BARGAIN DISCOUNT APPROVALS!

Do you want really FIRST-CLASS Approvals? Then try our Bargain Discount Approvals. Only picked stamps included, with book of sets as well. They're post free one way, too. Br. Cols. or B.C. and Foreign Mixed available. "Wants" lists of single stamps (not Countries) welcomed. Send with confidence. You won't be pestered to buy.

THE BIRKDALE STAMP CO.
104 Liverpool Rd., Southport, Lancs.



Postal Business Only
(NO CALLERS)



FREE

ANIMALS

Animals of the forest in HUNGARY for collectors. Large exquisite stamps, delightful pictorials, all can be added to your collection FREE. Make sure you trap these animal stamps now and hoard them in your collection, they may be valuable. Enclose 3d. postage, request our cheap discount approvals and illustrated price list.

LISBURN & TOWNSEND LTD. (MM), WEST KIRBY, WIRRAL

MODERN UNSORTED LOTS on paper. All contain large Pictorials! Gt. Britain with Coronation, 1 lb. (3,000) 5/-, 2 lb. 9/6. Br. Empire with Coronation and Q.E., 1 lb. 25/-, 1/2 lb. 13/-, 4 oz. 7/-, Australia with latest Q.E. and Coronation, 1 lb. 13/-, 1/2 lb. 7/-, 4 oz. 3/8. (abrd. 1/3 lb. ex.)
A. DAVIES, (M/5), 111 Holme Lacy Road, Hereford

FREE - THREE NEW QUEEN STAMPS

From SEYCHELLES will be sent Absolutely Free to collectors who send 2½d. stamp for postage and ask to see our famous approvals. **BROADWAY APPROVALS (M07), 12 CHEAPSIDE, LONDON E.C.2**

MYSTERY EXCHANGE PACKETS!

Exchange your "twicers" FREE from our guaranteed unsorted Free Exchange Packets which have circulated the World over. Different, profitable and interesting without payment. Details with 5 different GOLD COAST also FREE with APPROVALS. ENCLOSE POSTAGE. Dealers supplied. Overseas Agents Wanted.

ASTLEY & CO. (M)

103 CADMAN CRESCENT, WOLVERHAMPTON

100 DIFFERENT STAMPS FREE

To Approval Applicants enclosing 2½d. postage. **N. JOHNSON (Dept. M.M.), 19 Hillside, Slough, Bucks.**

6 DIFFERENT FINE USED CORONATION FREE

To all applicants for our Colonial Approvals. Please state Beginner or Medium and enclose 2½d. stamp.

MULLOCK AND SMITH (M)

81 REDBREST RD., MOORDOWN, BOURNEMOUTH

FOREIGN STAMPS

100 diff. 1/-; 250-2/-; 500-3/6; 1,000-10/-; 1,000 mixed stamps 5/-
50 diff. either Argentina, Bohemia, Canada, Yugoslavia, Portugal, Roumania, Sth. America or Swiss 1/6; 100 3/-.
Many others. List 1d. **HAND, Rosebery Road, Epsom.**

Morocco Agencies 1937 Coronation

This valuable complete mint set will be sent Absolutely Free to Approval Applicants enclosing postage.

YULWONTMOR STAMPS, P.T.S. (Dept. M)

175 PRIORY ROAD, ST. DENYS, SOUTHAMPTON

SUPER CANADIAN OFFER

FREE—GRAND CANADIAN PACKET of 1951 AND 1952 PRIME MINISTERS (4 VALUES), 1953 WILD ANIMALS SET of 3, 1953 Q.E. II 4 VALUES. ALL GENUINE APPROVAL APPLICANTS WILL RECEIVE THIS GRAND GIFT. ENCLOSE 2½d. POSTAGE.

H. B. LANG, BURNBANK, MAUCHLINE, Ayrshire

FREE - NIGERIA 1/- Q.E.

This fine bi-col. stamp will be given free to all genuine applicants for our famous ONE PENNY APPROVAL BOOKLETS of BRIT. COLONIALS. These Booklets abound with JUBILEES, PEACE, CORONATIONS, SILVER WEDDINGS and U.P.U., as well as the latest Q.E. II stamps. Best value in the world. N.B.—Enclose 2½d. stamp for Postage. **S. FENLEY LTD., 250 Charninster Rd., Bournemouth**

MAY STAMP BARGAINS for M.M. readers. ONE MONTH ONLY. All mixed selections at approx. half price PLUS usual discount and good quality

DON'T HESITATE—send 2½d. stamp **NOW** to: **MERTON STAMP APPROVAL SERVICE (M3)**
24 DANE ROAD, MERTON, LONDON S.W.19

FREE - 6 FLOWERS - FREE

These Six Beautiful stamps Free to all applicants who send 2½d. for postage and ask to see a selection of my approval sheets. No stamps sent abroad. **JOS. H. GAZE, 10 PIMLICO ROAD, CLITHEROE, LANCs.**

MAMMOTH MYSTERY PARCEL FREE, containing Triangular, Coronation, Large Rainier, Geo. VI Pictorials, etc., etc. (HOURS OF FUN SORTING). Write now, requesting discount approvals. Postage appreciated. Only genuine applicants need apply.

RINTON STAMP CO.

14 SUNNINGDALE DRIVE, BOSTON, LINCOLNSHIRE



8 FINE NEW Q.E. II FREE

(AS ILLUSTRATED). All Free to collectors asking to see our fine Approvals of Selected stamps. Send 3d. (abroad 6d.) for Postage and Illustrated list of sets. IF you wish you may join

"THE CODE STAMP CLUB." Year's Sub. 1/- You receive a Badge, Membership Card listing fine gifts. Approvals sent Monthly. We aim to satisfy you. Our service covers the World. (Monthly selections a speciality). Please state if Adult. (Postal Section Established 1897).

WRIGHT'S STAMP SHOP (M55), PALACE STREET, CANTERBURY, KENT

For other Stamp Advertisements see also pages 258 and xviii.

Stamp Collectors' Corner

By F. E. Metcalfe

ANTARCTICA

BRITISH Commonwealth stamps are collected all over the world, and in the U.S.A. only stamps of their own country are more popular with collectors. But when it was announced in June of last year that the Falkland Islands Dependencies were to have a new set, of values up to £1, there was a chorus of complaints.

Why? Well it was felt that such a sparsely populated territory could surely have no use for such high values, when really important countries like Canada were able to get along without them. But the authorities had a real philatelic trump card up

their sleeves. They had prepared a set which no one could possibly resist—a set of fifteen values, each one with a different design, and depicting a famous ship that had been employed in Antarctic exploration.

I might say that, like other collectors, I was very cross about the imposition, as I had described it; but when on 1st February I got my set—well I simply gazed over each stamp and that is the plain truth. From what I have read of other writers on stamp matters, many of them

felt the same way.

All collectors will want a set, either a short one, or a longer one if their pockets will allow. So I think that before we discuss the various values in detail, now would be a good chance to run through the philatelic history of what is almost Antarctica. It was announced during the war, in 1944 to be exact, that the four dependencies, Graham Land, South Georgia, South Orkneys and South Shetlands were to have sets of stamps. Great was the excitement. But then came rather an anti-climax, for then current stamps of Falkland Islands to 1/- were overprinted for the job. Yet sales were tremendous, so much so that even now they can be bought at a little over face.

These four overprinted sets were replaced in 1946 by a single set to 1/-, for use on the entire territory. The design showed a map of all the islands, and collectors have been having all kinds of fun ever since, for many varieties were to be found, such as the broken arc, the missing island, and the extra island.

These varieties have all been listed in the Commonwealth Catalogue, and they are very popular.

Incidentally there are two good shades in this short set, which

should be looked for. The normal 4d. stamp is of a bright reddish-claret, but some specimens are to be found much deeper in shade, and described in the catalogue as deep lake. The shade is catalogued at 8/6, while the normal stamp is only priced at 8d., which

shows that the variety is worth looking for. Then the frame of the normal 6d. value is rather pale orange, but there is a variety of a deep yellow-ochre colour. Again there is a big difference in



price, 9/6 for the shade and 10d. for a normal stamp.

This first map set had apparently been prepared in a hurry, and hence the many varieties. But there was a further change in 1948. We then got a set with the map of the centres redrawn, and gone were all those interesting varieties. Full details are given in the catalogue to tell how one can distinguish the 1946 emission from that of 1948. The chief point of difference has to do with the fineness of the lines of the map in the last issue. A new value was brought out in 1949, that of 2½d., and here we get nice shades, but one is as common as the other. The descriptions given in the catalogue are black and dark blue, at 4d., and black and dark grey-blue at 6d.

And this second "map" issue remained on sale until February of this year, when we got the fine ship set, to which I have already referred. Here are details of some of the ships represented.

1d., *John Biscoe*; American-built wooden boom-defence vessel, named after the greatest Enderby Brothers sealing skipper.
1d., *Trepassey*; wooden freight vessel built for Newfoundland Natural Resources Commission in 1944.
1½d., *Wyatt Earp*; Motor fishing vessel, built in Norway in 1910, that made two voyages to the Dependencies with the American explorer Lincoln Ellsworth, who made the first Trans-Antarctic flight from Graham Land to the Bay of Whales in 1935.
2d., *Eagle*; wooden screw whaler built in Norway in 1902 as *Sophie*.
2½d., *Penola*; three-masted auxiliary topsail schooner built in France in 1908.
3d., *Discovery*; steel single-screw steamship, employed in whaling and other scientific investigations in the Dependencies in 1929-37.
4d., *William Scoresby*; British-built steamship at present employed by the National Institute of Oceanography.

6d., *Discovery*; Barque-rigged vessel built in Dundee for Capt. R. F. Scott's 1901-4 Antarctic Expedition, subsequently employed by Sir Douglas Mawson's Expedition and moored in London as a Training ship for Sea Scouts until 1953.
9d., *Endurance*; Barquentine-rigged vessel and later sunk in the Weddell Sea during Sir Ernest Shackleton's second Antarctic Expedition.
1/-, *Deutschland*; a Norwegian sailing ship that once drifted for nine (Continued on page 260)





FIVE ISRAEL FREE

ABSOLUTELY FREE. To all who ask to see a Selection of Windsor Stamps On Approval, we will send Absolutely Free five interesting ISRAEL stamps—Israel is the country mentioned in the Bible, but which until recently has been called Palestine. Some of these new Israel stamps show ancient Jewish coins from Biblical days, and are inscribed in Hebrew; they will add lots of interest to Your Very Own Collection.

To get them, just write for Five Israel Free packet, and ask to see a Selection of Windsor Stamps On Approval. Please enclose 2½d. stamp for posting to you. Write to:

WINDSOR STAMP CO. (Dept. M), UCKFIELD, SUSSEX

FREE GIFT OF STAMPS

to every applicant for approval books. The GIFT contains 30 British Colonials including 8 K.G. VI mint—no Great Britain. Good discount is given and a list of 98 Gifts is sent. These can be chosen by you and vary in value according to the money sent for purchases. They include K.G. VI Silver Jubilees; ALL the Colonial Victory sets mint; and Foreign stamps. 3d. postage please.

C. A. RUSH, 38 Queen's Avenue, Whetstone, London N.20

GOOD VALUE GIFTS

Just request our PICTORIAL APPROVALS. Postage 2½d.

MARTIN'S STAMP CIRCLE (M.M.)

24 Catherine St., SHEFFIELD 3. Shop: 346 Abbeydale Rd.

1,000 STAMPS 7/6

ALL DIFFERENT. NO GREAT BRITAIN
500, 3/6. 250, 1/9. 100, 10d.

Br. Empire: 100, 1/6; 200, 3/6; 300, 7/3; 500, 15/6; 1000, 45/-; Triangulars: 10, 1/6; 25, 4/6; 50, 10/-; 100, 30/-; Rly. Engines: 15, 1/6; 25, 2/6; 50, 5/6. Maps: 10, 1/6; 25, 2/9. Ships: 10, 1/3; 25, 2/6. Postage 2½d. extra. All current British Colonial mint stamps in stock, including Coronation stamps and all new Elizabethan issues. Lists on request.

S. TATLOW & SONS, ECKINGTON, SHEFFIELD

QUEEN VICTORIA PACKET FREE!

Have you any REALLY OLD stamps in your collection? It is difficult to find stocks today, but we have managed to get together 10 different fine early issues of the British Empire, including stamps from Natal, Victoria and South Australia, all from FIFTY to EIGHTY YEARS OLD, showing Queen Victoria's portrait. We will send them ABSOLUTELY FREE to all genuine applicants for our STERLING discount approvals. You'll be delighted with the grand selection of triangulars, Coronations, new issues, &c., offered from 1d. each. Just send 2½d. postage today to:

STERLING STAMP SERVICE
(Dept. MMZ), Lancing, Sussex

FREE — STAMPS CATALOGUED 5/-
to applicants for 1d. approvals.

COX, 17 STONELEIGH PARK ROAD, EWELL

DENMARK All diff. 100, 1/8; 150, 4/-; 200, 8/4.
All commems. 30, 3/6; 50, 7/6. Post 2½d.
FRED HARLOW, 2 ROBYN'S WAY, SEVENOAKS, KENT

FREE! 20 Mint (over 30 years old, C.V. E1) Request Approvals
(2½d.) **G. BARNETT (M), LIMINGTON, YEOVIL**

For other Stamp Advertisements see also pages 256 and xviii.

FALKLAND Is. Splendid new "Queen" set of handsome mint picts. showing ships. FREE. 2½d. for approx. please.
COOMBERS STORES, 20 MELBOURNE ROAD, CHATHAM

FREE TO ALL COLLECTORS

4 NEW QUEEN STAMPS including GRENADA

Send 2½d. postage.

BARGAIN 50 CHINA - - 1/3
C.O.D. extra.



25 MONACO 1/6	50 SPAIN - 1/-
50 JAPAN - 1/3	50 RUSSIA - 2/3
25 EGYPT - 1/3	25 PERSIA - 1/6
100 B. Cols. 2/-	100 F. Cols. 3/-
200 B. Cols. 4/6	25 Vatican - 3/-
500 All diff. 5/6	1000 All diff. 10/-

G. P. KEEF — WILLINGDON — EASTBOURNE

PACKET OF QUEEN STAMPS FREE

To help with your collection of Q. Elizabeth stamps, we will send this splendid packet of new issues FREE to all asking for approvals and enclosing a 2½d. stamp for postage.

These stamps SELL—good discount is given—and you will be pleased with each selection you receive.

For GOOD collecting write NOW to:

GEM STAMP CO. (Dept. M)

514 FAIRFAX DRIVE — WESTCLIFF — ESSEX

STAMP OUTFIT FREE

Watermark Detector, Perforation Gauge, transparent envelopes and TEN pictorials incl. Coronation, Triangular, Afghanistan. Send 3d. postage, ask for approvals.
ROSTON (J.), 106 St. Dunstan's Road, London W.6.

FREE! A packet containing large pictorial stamps, two triangulars and a 5/- (USED) stamp of Australia will be sent FREE to all applicants sending postage and requesting discount approvals.
F. WEBSTER (M3), 46 DOVEDALE CIRCLE, ILKESTON, Derbyshire

GREAT BRITAIN

1858 PENNY REDS. Plate Numbers 71-224. 100 different 17/6. 50 different 7/6. Sample 25 for 3/-.
HILLIER — 35A NORTHDOWN AVENUE — MARGATE

FREE 50 different incl. pictorials. Send 2½d. for bargain discount approvals incl. pictorials at 1d.
G. M. WALKER, 13 BROOM ROAD, HALE, CHESHIRE

SPECIAL FIJI 1954 HEALTH SET MINT FREE TO APPROVAL APPLICANTS 2½d. POSTAGE.
OFFER A. Cunningham (Dept. MM), 36 Doonfoot Rd., Ayr

Stamp Gossip

U.N. STAMPS

ENQUIRIES about the stamps of the United Nations often reach me, so they must be increasing in popularity. The pair of commemorative stamps issued on 11th February in honour of the work being done by the U.N. Food and Agriculture Organization therefore will interest many readers. The stamps were designed by the Dutch artist, Dirk Van Gelder, and our own Thomas De La Rue, London, were the printers. The design is striking, showing as it does a head of wheat as the symbol of the organization honoured, and the usual five languages are used for the lettering.

Without a doubt a U.N. collection is going to become very attractive as time goes on, as far as appearance is concerned at any rate.

COINS AND THINGS

I recently received a cover from Israel bearing one or two of the "coin" stamps. We are now used to seeing stamps with this design. To a casual glance they seem all the same, but they are anything but that. For instance, just examine the illustration of two of the four stamps issued last December. The 80 pruta value depicts a coin struck by Alexander Jannaeus of the House of Maccabi, 103-76 B.C. and a half open flower, with an inscription meaning *Jonathan the King*. The 95 pruta stamp illustrates a coin struck in the fourth year of the first War of Liberation, 66-70 A.D. Three palm branches can be noticed, and the inscription means *A quarter shekel*. Each of these "coin" stamps has a story to tell. They are fairly common, so some at least should be easily obtained for very little.

CACTI

Many readers must have seen that movie, titled *Dude Ranch*, which showed a scene in which people were riding through country where huge cacti, looking



like corrugated tree trunks, took the place of trees. Weird looking things, as the writer can testify first hand. Well the U.S.A. issued a stamp on 30th December, to commemorate the Gadsden Purchase, that depicts these strange specimens of vegetation, and I am sure that many will want copies for their thematic collections.

A word will not be out of place, perhaps, on the event that the stamp commemorates, for notes on the why and wherefore of a commemorative stamp, if neatly written in a collection, improve its appearance greatly. Just a hundred years ago, America made one



of its wonderful land purchases. What bargains Uncle Sam has made in the past Canada, France and Mexico can testify. For a mere ten million dollars he purchased from Mexico 45,535 square miles of

territory, and thereby acquired resources of various metals, including gold and copper, as well as a great area of fertile agricultural and grazing land.

EASTER LILIES

It will be remembered that recently I mentioned the handsome new set that Bermuda had issued. The 4d. value showed two magnificent Easter Lilies, and the Crown Agents gave some very interesting details of this important Bermudan export.

Bulbs were introduced into Bermuda just a century ago—by mishap! A missionary was returning from Japan, but the vessel in which he sailed had to put into Bermuda in distress. The Rector of Smiths and Hamilton—parishes in Bermuda—called on his friend the missionary, and the latter made the Rector a present of some lily bulbs. These were distributed and they flourished greatly, as any one who has seen a field in full bloom can testify. It is lucky that they bloom about Easter—hence their name—and thousands of boxes are flown to the U.S.A. each year. This is a lily that blooms well in our own country also, particularly in those old cottage gardens, in the heart of the country, where they are not troubled with a sooty atmosphere.

1953 OR 1954

Stamp circles were quite excited recently when Sudan issued a set of stamps to commemorate self government, for the London Government Agency let out the wrong ones. It appears that some of the new issue services distributed sets with the 1953 date instead of the coming 1954, and some collectors who read these lines may have got hold of the good ones. Just look to make sure, for if you are lucky you have a set worth more pounds than you would pay shillings.



BERMUDA THREE POWER TALK ISSUES

Collectors were afraid that there would not be enough of these stamps to go round. Well, here are the figures of stamps sold, which were supplied to the writer by the Bermuda Post Office: 3d., 424,140; 1/3, 311,340. Just about enough to cover needs, but at present very reasonable prices. Maybe it will be better to buy your set without delay. That is a tip.

Let me also remind you of the colonials we are getting now, with wonderful new designs, such as the sets for Gibraltar and Nigeria, or with new portraits, like the Fiji stamp illustrated. There will be plenty of time to pick these up, so buy what you can easily afford.

Millions of Them!—(Continued from page 221)

seen in the upper picture on page 221. The blanks are fed down the chute D, and arrive between a fixed block and a sliding block, each carrying one of the thread-forming dies. B is the die on the sliding block and C that on the fixed block, A representing the head of a bolt that is actually having a thread rolled on it. The faces of the dies roll the bolt along between them and squeeze the shank into the thread form required. The bolt and the dies become hot during this process, so oil is sprayed on them from the pipe E. Normally this pipe is over the line down which the bolt is rolled when the machine is working.

All that the bolts need now is cleaning and coating with brass. The brass finish is given by placing the bolts in a solution of copper and zinc salts, so that an electric current passes to them from a brass anode.

Mysterious Orchids—(Continued from page 229)

painful process it is for an orchid to reach maturity, it will be no surprise to you that many of our orchids are so exceedingly rare that it is doubtful whether they still exist or have in fact become extinct.

The extensive ploughing of pasture land has spelt disaster to many local colonies of orchids and it is possible that the monkey orchid, which until a couple of years ago survived in one place in Oxfordshire, has been destroyed in this way. The lady's slipper is found only in one area in Yorkshire, and every effort is being made to protect it from thoughtless people who cannot resist picking a rare flower when they see it.

At one time I used to gather the more common orchids myself when I found them, but when I came to understand them better, and realised how handicapped they are in the fight for survival, I made a promise never to pick one again. I leave them all to seed so that in future years people will still be able to enjoy these beautiful and interesting flowers.

Cycle Speedway—(Continued from page 239)

team addresses.

If your local team does not think that you are quite good enough for them, do not be dismayed. Instead form your own team! You will need eight riders—six team men and two reserves—and you must then decide upon a team name and team colours. Most important of all, you will have to contact your local Parks Committee to see if they can assist you to find a suitable patch of ground for a track.

The rules of the sport are outlined in the Cycle Speedway Annual and should be carefully studied. Equipment? Well, very briefly you will want an old bike, or one of the specially produced models that will set you back at least ten pounds; a good crash helmet; and leather gloves to protect the hands from cuts and dirt. You should have also a roll neck jersey or thick shirt, strong boots or shoes—an old pair—that will take quite a considerable amount of wear and tear, and riding breeches, or your oldest pair of trousers!

Study the photographs printed with this article. They will give you a guide as to how you should look when you are dressed and ready to race.

New Meccano Model—(Continued from page 249)

Rod so that it engages the Contrate 15.

To make the front axle beam fix a 4½" Strip to the strips 1 with Angle Brackets. Fit two 1"×½" Angle Brackets 27 with Fishplates, and bolt one to each side of the bonnet. Now mount a 1½" Rod in each end of the axle beam and also in one of the Angle Brackets 27. Fit each Rod with a Crank 28, but space the Crank from the Angle Bracket 27 by a Compression Spring. Connect the ends of the

Cranks with a 4½" Strip 29 attached to them by lock-nutted bolts.

For the steering column a 6½" Rod is used. At one end support the Rod in a Semi-Circular Plate attached to the Plates 5 by an Angle Bracket. Mount its other end in a 1½" Strip bolted to the 1"×½" Angle Bracket 30. Fix a Collar on the end of the Rod, and screw a Threaded Pin into the Collar so that it engages between two Fishplates bolted to the Strip 29. Now mount each front wheel freely on a ½" Bolt, and screw the Bolt into the boss of one of the Cranks 28.

For the driving seat two Trunnions are bolted to a 3" Flat Girder. Connect two 2½" Stepped Curved Strips 31 to the ends of the Flat Girder by Angle Brackets, and bolt their upper ends to an Angle Bracket fixed to the Strips 6. Finally fix two 2½"×½" Double Angle Strips, bolted together, at one side of the bonnet, using ½" Bolts, and on the other side fix four Collars, this time using ¾" Bolts.

To build this novel racing car you will require these parts: 2 of No. 1; 10 of No. 1b; 8 of No. 2; 10 of No. 2a; 4 of No. 3; 2 of No. 4; 4 of No. 5; 2 of No. 6; 8 of No. 6a; 16 of No. 10; 1 of No. 11; 7 of No. 12; 1 of No. 12a; 2 of No. 12b; 2 of No. 12c; 2 of No. 14; 1 of No. 15b; 1 of No. 17; 3 of No. 18a; 2 of No. 20; 5 of No. 20a; 1 of No. 23; 1 of No. 25; 1 of No. 26; 2 of No. 29; 116 of No. 30; 37; 36 of No. 37a; 32 of No. 38; 1 of No. 45; 4 of No. 48a; 2 of No. 48b; 1 of No. 55a; 11 of No. 59; 2 of No. 62; 1 of No. 63c; 5 of No. 90a; 1 of No. 103a; 1 of No. 103b; 1 of No. 109; 7 of No. 111; 3 of No. 111a; 14 of No. 111c; 1 of No. 111d; 1 of No. 115; 2 of No. 116a; 2 of No. 120b; 2 of No. 126; 4 of No. 133a; 4 of No. 142a; 1 of No. 147a; 1 of No. 147b; 1 of No. 147c; 1 of No. 148; 1 of No. 171; 2 of No. 186; 2 of No. 186c; 4 of No. 187a; 2 of No. 189; 1 of No. 192; 2 of No. 214; 4 of No. 215.

Stamp Collectors' Corner—(Continued from page 257)

months in that dangerous Weddell Sea. 2/-, *Pourgoi Pas*; a barque-rigged vessel lost off Iceland in 1936. 2/6, *Francais*; built for the French Antarctic Expedition of 1903-5, it was lost afterwards in the River Plate.

5/-, *Scotia*; Barque-rigged whaler used by the Scottish Antarctic Expedition of 1902-4. 10/-, *Antarctic*; a wooden sealer used in several polar expeditions, and finally crushed in the pack ice of Weddell Sea. £1, *Belgica*; a barque-rigged sealer used by the Belgian Antarctic Expedition of 1897-98.

Doesn't the romance conjured up by these famous names make you want to have a set?

This Month's Special Articles

	Page
Diesels on the Clyde	212
by W. A. C. Smith	
The Road to the South	214
by "North Western"	
Hand-Made Nails	217
by W. K. V. Gale	
A Flying Radar Station	218
by John W. R. Taylor	
Kingley Vale	223
by Garth Christian	
Mysterious Orchids	228
by M. A. Savonius, Dip. Hort.	
Railway Photography in the West Country	232
by H. Gordon Tidey	
A Job for the Breakdown Gang	235
by S. C. Townroe, A.M.I., Mech.E.	
Cycle Speedway	238
by Graham Payne	
The World's Richest Island	240
by Francis J. Knight	
America's First Convertiplane	245
by John W. R. Taylor	

Competitions! Open To All Readers

Prize-winning entries in M.M. competitions become the property of Meccano Ltd. Unsuccessful entries in photographic, drawing and similar contests will be returned if suitable stamped addressed envelopes or wrappers are enclosed with them.

An Easy Crossword Puzzle

CLUES ACROSS

- Chasm
- Tiny mark
- Unsoiled
- First coat
- To cool
- Recede
- Cowboy story
- Become liable
- Cut across
- Nomad
- Hunting cry
- Female
- Draw
- Boats
- Horn sound
- A fish
- Make amends

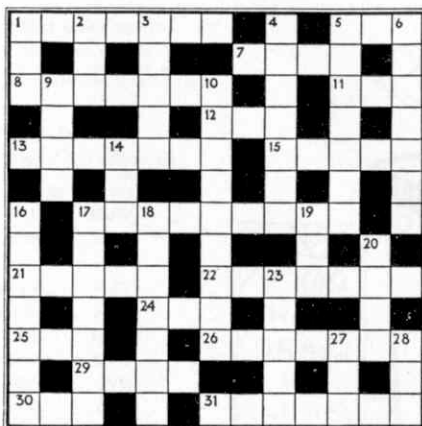

CLUES DOWN

- Dandy
- Snow-shoe
- Join
- Kind of wheel
- Shortage
- Slender shoot
- Dangerous to shipping
- Produces
- Colour
- Sirius
- Irreverence
- Child's paradise
- Incision
- River
- Wanderer
- Liquor
- Help

This month we present another of our popular crossword puzzles. There are no traps in the clues, or alternative solutions, and every word used, apart from names, can be found in a standard dictionary.

There are two sections in the competition, for Home and Overseas readers respectively, and in each prizes of 21/-, 15/- and 10/6 will be awarded for the best solutions, and there will be a number of consolation prizes. If necessary the judges will take neatness

and novelty into consideration when making their decisions. Do not cut out the diagram. Make a copy of it for your entry, and on the back of it write your full name, address and age.

Entries should be addressed: *May Crossword, Meccano Magazine, Binns Road, Liverpool 13.*

The closing date in the Home Section is 30th June, and in the Overseas Section 30th September.

Aircraft in Hiding

It is some time since we had a contest about aeroplanes, so here is one in which the names of 12 current types of British, American and Canadian aircraft have been hidden in the sentences below.

- The latest jet fighters demonstrate the great advance made since the war.
- Excitedly Derek and Travis counted the coins they had found.
- The shot terrified the birds, which rose in a flock.
- When little David Morgan nettled his hand he yelled.
- The culprit had deliberately torn a dozen pages from the book.
- There are foreign consulates in many important cities.
- Some accidents could be averted by taking greater care.
- The Museum also lent some rare tapestries for the exhibition.
- I hope that you will come through the ordeal alright.

- This new bridge will span the river just above the town.
- It is uncertain whether the convict or the warden is most to blame for what happened.
- The passenger train engine sometimes acts as shunter at wayside stations.

Competitors are asked to identify the aircraft completely by giving, in addition to the type, the nationality, maker's name and the duty or duties for which the machine concerned has been designed.

There will be separate sections for Home and Overseas readers, and in each of these prizes of 21/-, 15/- and 10/6 will be awarded, with consolation prizes for other good efforts. Entries must have the competitor's name, address and age written on the back and be forwarded to *May Aircraft Contest, Meccano Magazine, Binns Road, Liverpool 13.* Closing dates: Home Section, 30th June, Overseas Section, 30th September.

Fireside Fun

Mother: "What a wasteful boy you are. Look at all the butter and jam you've put on that slice of bread."

Son: "No, not wasteful mum, I'm thrifty. Don't you realise this same slice of bread is serving for both the butter and the jam?"



Tom: "You can't hold a candle to it."

Jim: "What are you talking about now?"

Tom: "Gunpowder."

Referee: "Free kick there!"

Captain of Home Team: "For whom?"

Referee: "For us."

The army cook on active service wanted to be truthful, but at the same time yearned to write an impressive letter to his friend. His problem was solved one day when eggs were on his unit's menu. "As I pen these words," he wrote, "shells are bursting all around me."

An aspiring vocalist had just completed a lesson. "Professor," she asked, "do you think I shall ever be able to do anything with my voice?"

"Well," replied the instructor, "it might come in handy in case of fire."

"Has the new florist any children?" asked Mrs. Jones of her neighbour.

"Yes," snorted the good lady. "A girl who is a budding genius and a boy who is a blooming nuisance."

BRAIN TEASERS

A MATCH TRICK

Arrange on a table 12 matches as shown here to form four squares. Then lift four of the matches and replace them so that only three squares of equal size appear in the final arrangement.

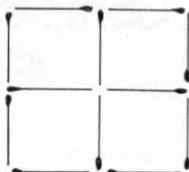

FIRST INTO LAST

It is said that the last shall be first. Can you make first nearly last merely by adding one letter?

A NOVEL WORD MAKING PUZZLE

By adding one letter to each end of the 3-letter words given below you can make a new word that will answer the clue given.

Word	Clue
RAN	Name
CID	Liquids
VEN	A Function of some kind
REA	May be a colour or a liquid
HER	Not Here
VAD	Avoid
AVI	There's a giant in this story
ASO	Sometimes after stone

SOLUTIONS TO LAST MONTH'S PUZZLES

A MATTER OF WEIGHTS

If a man had a pair of scales and four weights of 1, 3, 9 and 27 lb. respectively, he could weigh any object having a net weight of between 1 and 40 lb.

SQUARING THE NUMBERS

The solution to this interesting puzzle is found by arranging the numbers 1 to 25 as shown in the diagram alongside, so that each column of figures, either horizontal or vertical, totals 65.

15	20	2	10	18
21	17	1	14	12
4	3	13	23	22
9	19	25	7	5
16	6	24	11	8

THE KING IN HIS CASTLE

On each of the four nights mentioned in the puzzle, the soldiers and their friends stationed themselves around the Castle in the arrangements shown in the diagrams on the right, so that no matter in which direction the King looked he always saw nine soldiers on each side.

4	1	4
1	K	1
4	1	4

2	5	2
5	K	5
2	5	2

1	7	1
7	K	7
1	7	1

	9	
9	K	9
	9	

*It's more than an impression—
it's a fact that more cyclists
than ever ride on*

DUNLOP

Here's FUN for EVERYONE with SPEARS GAMES

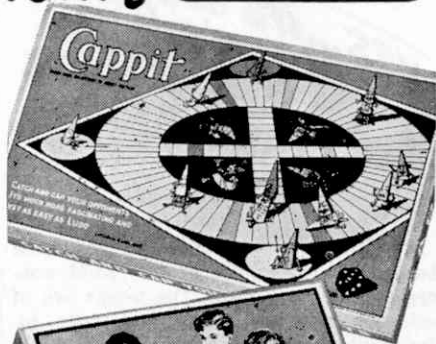

CAPPIT

A game for 2 – 4 players, who try to "Catch and Cap" their opponents. As easy as ludo, but much more exciting. **7/9**

TELL ME

The queen of quiz games. Spin the wheel and roll out the questions! Endless fun for any age. Any number of players, the very thing for your party. **6/3**

Obtainable from good toyshops and departmental stores. If your dealer cannot supply, write for address of nearest stockist to:

J. W. SPEAR & SONS LTD.
DEPT. M • ENFIELD • MIDDLESEX



With every set of Lott's Bricks you get a coloured illustrated book which shows you how to build wonderful real-life models. The bricks are of coloured artificial stone, practically indestructible, and the sets include all the accessories you need, including transparent windows which can easily be illuminated.

Ask for Lott's Bricks for your next birthday —or sooner!



For 'Back Room Boys'—

LOTT'S CHEMISTRY SET

Harmless fun with a sound scientific background. Start building your own laboratory now—spare apparatus and chemicals are readily available.

Ask to see them at your toy dealers, or write for price list, enclosing 1½d. stamped addressed envelope.



LOTT'S BRICKS LTD
(Dept. M.M. 8) WATFORD · HERTS

New!



PECO WONDERFUL WAGONS ADD COLOUR TO YOUR RAILWAY

These truly Wonderful authentic copies of colourful Private Owner Wagons, are complete in every detail, including sprung axleboxes and buffers and require no painting. Anyone can assemble these simple kits and produce perfect models to grace his layout. Supplied with wheels to suit scale and all the Proprietary systems.

TWELVE DESIGNS TO CHOOSE FROM
ONLY 5/11 PER KIT

THE PRITCHARD PATENT PRODUCT CO. LTD.
PECOWAY, STATION ROAD, SEATON, DEVON

FOR PERFECT LUBRICATION THE "DERMIC" OILER

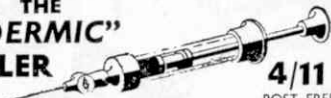

4/11
POST FREE

Manufactured by us specially for clean and accurate lubrication. If you own a Model Railway or Meccano Set the "DERMIC" will be invaluable. Packed in carton with full instructions.

GET ONE FROM YOUR LOCAL DEALER
or send direct to:

S. & B. PRODUCTIONS
Portland Rd., 5, Norwood, London S.E.25

THE SWORD AND THE COMPASS

By MARGARET LEIGHTON

The exciting life story of John Smith, who was born a Lincolnshire village lad in 1580, became a swash-buckling hero and a soldier of fortune, and finally achieved his aim by establishing an English colony in Virginia.

CROWN LIBRARY

From any Bookseller

7s. net

WARNE, 1 Bedford Court, W.C.2

Swim and Play the Modern Way

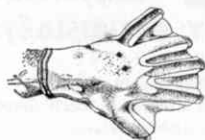

Rubber Handflippers with webbed fingers complete the waterman's outfit, 9/6, p. and p. 6d.



See under water with these French-made goggles, 12/6, p. and p. 6d.

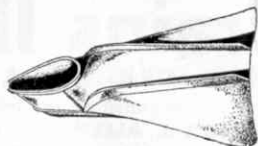

All Rubber Flippers add to your water skill. Sizes: 2-4, 17/6; 5-9, 29/6, p. and p. 1/6



These bright rubber beach balls are very strong with overlapped seams and moulded, push-in valves. Three sizes and colour schemes to choose from: 11 in. and 15 in. with four panels, red, white, blue, yellow and red, white, green, yellow, 4/9 and 8/6. Or 9 in. with two panels, green/yellow or red/yellow, 3/6, p. and p. 6d.



Rubber Beach Rings in red/yellow, green/yellow or blue/yellow. Approx. 20 in. deflated, 7/11, p. and p. 1/-



Ride buoyantly on this gay rubber duck in red/yellow, green/yellow or blue/yellow with contrasting harness, £1/-, p. and p. 1/-

Hamleys
ESTD 1760
HAMLEY BROTHERS LTD

The Finest Toy Shop in the World
200-202 Regent Street, London W.1
(our only address) Tel. REGENT 3161

You can develop your own snaps with this TRIAL SET

Doing the work yourself is half the fun of photography. You save money and have no end of a thrill in making the negatives and getting a few prints from them. It's quicker, too. You see the results within a few hours of taking the snaps. Start, right away, by sending for this trial set.

It comprises

- 1-oz. (25 cc.) bottle of the famous AZOL developer.
- 4-oz. tin of Acid Fixing salts.
- 2 M-Q Pactums, print developer.
- 1-oz. (25 cc.) bottle of 142.
- 25 sheets of Contact paper, size $2\frac{1}{4} \times 3\frac{1}{4}$ inches and the instruction book which tells you how it is all done.

PRICE
5/6

includes the purchase tax, packing & postage.

Enclose P.O. Write your name and address in block capital letters and mark the front of the envelope clearly
MECCANO MAGAZINE



NEW HOME PHOTOGRAPHY

You should read this book. Over 100 pages, 130 illustrations. Packed with all sorts of useful hints and dodges for getting good results. Get a copy today. It will help you to make better snapshots. Your dealer sells it, or a copy will be sent, post free, for 2/6. Enclose P.O. Write name and address in capitals and mark envelope
MECCANO MAGAZINE

ONLY ONE trial set can be sent under this offer. When the chemicals are used up go to the photographic dealer from whom you buy your films. He keeps a stock of everything you are likely to need and will be able to help you with much useful advice.

JOHNSONS OF HENDON LTD., LONDON N.W.4

Trains Illustrated ^{1/6} MONTHLY

THE LEADING MAGAZINE FOR ALL RAILWAY ENTHUSIASTS

Illustrated by the finest railway photographs — Contributed to by

CECIL J. ALLEN - HAMILTON ELLIS - G. FREEMAN ALLEN

and all the best-known railway journalists — Published on the 1st of each month

Obtainable from bookstalls and booksellers everywhere or from the address below—

—and here are the latest *San Allan* books

RAILWAYS

ABC LOCOSHED BOOK

—up to the minute allocations of every B.R. locomotive .. 2/6

TRAINS ALBUMS

(1) L.M.R. (2) E.R. (3) W.R. each 1/6

PREMIER LINE IN PICTURES

Locos. and trains of the L.N.W.R. .. 2/6

1954 ROAD BOOKS

ABC of BRITISH CARS .. 2/-

ABC of BRITISH MOTOR

CYCLES (New Edition) .. 2/-

ABC of LORRIES and B.R.S. 2/-

AIRCRAFT

ABC MILITARY AIRCRAFT RECOGNITION

ABC CIVIL AIRCRAFT RECOGNITION

ABC CIVIL AIRCRAFT MARKINGS

ABC CONTINENTAL MILITARY AIRCRAFT

ABC of HELICOPTERS

These titles are 2/6 each

BUSES

ABC of LONDON TRANSPORT BUSES, COACHES, TROLLEY BUSES

1954 .. 2/6

FARES PLEASE! .. 12/6

The Story of London's Transport

OVERGROUND .. 2/-

ABC of BRITISH BUSES

L. Lancs. and N. Wales .. 2/-

Published by - *San Allan Ltd* - available from

LOCOMOTIVE PUBLICATIONS, 32 RAILWAY APPROACH, LONDON BRIDGE STN., S.E.1

THE FLYING FLEA

2/11

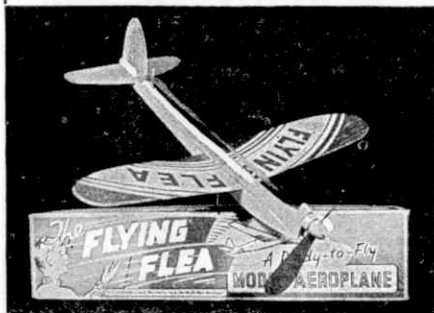

Ask your local Toy Dealer for this

12" SPAN, READY-TO-FLY MODEL

or write to us for the address of your nearest stockist and details of complete range of Gliders and Aeroplanes.

FROM 6d. TO 15/6

"Silver Ghost" — "Bowen Pathfinder" — "Moth Minor" — "Bantam Flyer," etc., etc.

JAVIS MANUFACTURING CO.

74 Encroft Rd., Marple Bridge, Stockport

THE 'STIP MASTER' 35 mm. STRIP FILM PROJECTOR

55/-



post & pkg. 2/- extra or C.O.D.

★ High Quality Focusing Lens, projects picture up to

8 feet x 6 feet. ● Plugs direct into mains. ● Finished Gold and Silver. ● Complete with Film. ● Magnificent film and colour film of Entire Coronation, 7/6 extra. Huge List of films from 1/- to 3/6 enclosed with projector.

FOWDEN FILM & OPTICAL SERVICE, 2 Hastings St., Luton

CHEMISTRY APPARATUS

Send 2½d. Stamp for latest

PRICE LIST

BOOKLETS:

"Experiments" 10½d.

"Formulas" 10½d.

"Home Chemistry" 2/3

Post Paid



BECK (Scientific Dept. G), 60, High Street STOKES NEWINGTON, LONDON N.16

RAWPLUGS

for speedy screw-fixing

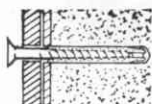

For simple and speedy fixing of equipment, racks, motors, etc., to brick, stone or concrete—use Rawplugs! There's a Rawplug for every size of screw, and Rawplug

easy-to-use Tools for speedy hole boring. Popular Outfit 2/6d., Household Outfit 6/-. Handyman Outfit 9/6d., each complete with Rawplugs, Screws, Hooks and 16-page booklet "Hints on Fixing."



RAWPLUG

DURIUM

Registered Trade Mark

TIPPED DRILLS



for fastest-ever masonry drilling

There's nothing to equal the astonishing speed of these drills in penetrating brick, stone, tiles, etc. The Durium new process carbide tip is harder than any metal or alloy, giving fifty times more life than ordinary drills. In sizes from 5/32 in. to 1 in. diameter—can be used in hand or electric drills.

TRADE ENQUIRIES INVITED • THE RAWPLUG COMPANY LIMITED, LONDON S.W.7

Micromodels

BUILD YOUR OWN MICRO-MUSEUM

Locos • Ships • Aero • Buildings • Engines • etc.

OVER 100
MODELS

SEND
Stamped,
addressed
envelope for
illustrated
catalogue

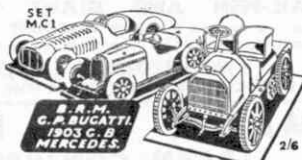

MICROMODELS LTD.

3 (MM) Racquet Court, Fleet Street, London E.C.4

HIGHSTONE UTILITIES

Soldering Irons. Our new streamlined Iron is fitted with a curved pencil bit; 200/250 v. 50 watts, 11/6. **Standard Iron** with adjustable bit, 200/250 v., 60 watts, 13/6. **Heavy Duty Iron**, 150 watts, 16/6, all post 6d. **Crystal Sets.** Our latest model is a real radio receiver, fitted with a permanent crystal detector, 12/6, post 8d. **Spare Permanent Detectors**, 2/- each. When ordered separately, 2/6, with clips and screws, 2/10, post 3d. **Headphones**, brand new, S.G. Brown, G.E.C., etc., 23/-, and super-sensitive, 30/-, post 1/-; **New Headphones**, 10/-, Balanced armature type (very sensitive), 12/6. Both post 1/-; **New Single Earpieces**, 3/6. **Bal. Armature type**, 4/6; **ex-R.A.F. earpiece**, 2/6, post 4d. **Headphones**, in good order 6/- (better quality), 7/6, all post 1/-; **Meters**, 15 v., 2½ in., m/c, 9/6; 150 v., 2½ in., m/c, 10/-; 3.5 amp., 2 in. T.C., 6/-; 4 amp., 2½ in. T.C., in case with switch, 9/6; 100 m/a, 2 in., m/c, 7/6; **Units** containing 2,500 microamp. movements, 7/-, all post 1/-; **Bell Transformers.** These guaranteed transformers work from any A.C. Mains, giving 3, 5, or 8 volts output at 1 amp., operate bulb, buzzer or bell. Will supply light in bedroom or larder, etc. Price 9/-, post 8d. **Similar Transformer** but with output of 4, 8 or 12 volts, 12/6, post 1/-; **BELLS**, 6/-; **BUZZERS**, 4/6, both post 5d. **Ex-R.A.F. 2-valve (2-volt) Microphone Amplifiers** as used in plane inter-com., in self-contained metal case; can be used to make up a deaf aid outfit, intercommunication system, or with crystal set, complete with valves and fitting instructions, 20/-, post 2/-. Ditto, less valves, 10/-; **Hand Microphones**, with switch in handle, and lead, 4/6; **Tannoy**, 6/-; **Similar instrument**, moving coil, 7/6, all post 9d. **Mask Type**, 3/6. **Mike Buttons** (carbon), 2/-; **Moving Coil**, 4/6; **Transformers**, 5/-, post 4d. each.

Letters only. Money refunded if not completely satisfied.

58 New Wanstead, London E.11

Illustrated List sent on request with 1½d. stamp and S.A.E.

THEY'RE SMASHING!

Send 1½d. stamped, addressed envelope for full details of our new easy-to-build Rex OO Wagon Kits.

NOTE NEW ADDRESS:

ERG (Bournemouth) LTD
729 CHRISTCHURCH ROAD, BOSCOMBE
BOURNEMOUTH

BOOKS:

A.B.C.s, L.M.R., E.R., W.R., S.R.	2/-
Layout Plans	1/3
Scenic Modelling	1/9
Trix Year Book and List	2/6
British Standard Locomotives	1/6
RAILWAY ACCESSORIES:	00 0
S/hand Rail Men, Passengers per doz.	2/6 2/6
Min. Pea Lamps, 2.5 volts	1/- 1/-
Min. Pea Lamps, 14 volts	1/2 1/2
Spare Sockets for bulbs	4½d. 4½d.
14v. C/light Signals and Switch	19/6 19/6
Water Columns	2/- 2/6
Working Ground Signals	2/7½ 2/6
Imitation Coal	9d. 9d.
Small Bushy Trees	2/6 2/6

Postage extra New "00" or "0" Parts List 6d. per post.

TYLDESLEY & HOLBROOK (M.E.T.A.)
109 DEANSGATE, MANCHESTER 3

WEBLEY AIR PISTOLS

Marvellously
accurate for
target practice



No licence required to purchase
for use on enclosed premises.

Write for Catalogue of Air Pistols,
Air Rifles and Accessories.

WEBLEY & SCOTT LTD.,
87, Weaman Street, Birmingham, Eng.
W.S.S.R.

H.A.C. SHORT WAVE EQUIPMENT

Noted for over 18 years for . . .
S.W. Receivers and Kits of Quality.

Improved designs with Denco coils:
One-Valve Kit, Model "G" Price 25/-
Two-Valve Kit, Model "E" Price 50/-

All kits complete with all components, accessories,
and full instructions. Before ordering call and
inspect a demonstration receiver, or send stamped,
addressed envelope for descriptive catalogue.

"H.A.C." SHORT-WAVE PRODUCTS
(Dept. M.M.), 11 Old Bond Street, London W.1

**Boys, swim like the Frogmen
with
"SPEEDFLIPS"**

Beautifully moulded high quality black
Rubber Swimming Feet.

Speedflips were developed from tests by world-
famous swimmers, and are now used and approved
by leading swimmers and coaches. They are
produced in two sizes, small for sizes 4 to 6, and
large for size 6 upwards. Price 29/6 post free from
GUISE BROS. LTD., Hunstanton Norfolk

STAMP ADVERTISEMENTS

(see also pages 256 and 258)

**ALL THESE STAMPS
FREE**



IF YOU ASK TO SEE OUR "CHEAPER THAN OTHERS" STAMP
APPROVALS AND SEND 2½d. POSTAGE.

350 MONSTER BARGAIN PACKET 5/-

different stamps (Cat. value about 60/-) postage 3d.

HARRY BURGESS & CO. (MM8), PEMBURY, KENT

**FREE! SEYCHELLES
NEW ISSUES**

**QUEEN ELIZABETH II ISSUES SHOWING
SAIL-FISH AND GIANT TORTOISE.**

Just ask to see my 50% DISCOUNT APPROVALS
containing many Q.E. II stamps. Postage appreciated.

M. THEOBALD (MM39)

6 DELL CORNER, WEST DRAYTON, MIDDLESEX

**MAGIC FOR BOYS
LEARN CONJURING
and entertain your friends**

Send 6d. for illustrated Catalogue of tricks YOU
can do, and free Magic Competition with
UNLIMITED PRIZES.

THE BOY'S MAGIC SERVICE (M)
Prestatyn, N. Wales

★ **PLANS AND KITS FOR OVER 600 MODELS** ★
THE NEW

Modelcraft Handbook
features plans and accessories.

Price only 1/-, includes a full refund Voucher.

Send for your copy now to:

MODEL CRAFT LTD.

77 (H) GROSVENOR ROAD, LONDON S.W.1

SHORTHAND in 1 Week. Test lesson 2½d. stamp.
Duttons (MO/SV), 93 Gt. Russell Street, W.C.1

Now! FRETSAW INLAY

Marquetry the EASY Way!

IF you like marquetry work, you MUST try Fretsaw Inlay. It has many advantages over knife inlay work with veneers, and is easier, yet the results are equal to the finest marquetry! Using a fretsaw, all the pieces are cut at once—and must fit perfectly. You get THREE good pictures from four pieces of wood—quite a consideration when you are making the pictures for sale—and all are cut at the same time. There's no mess and no bother with Fretsaw Inlay. The kit illustrated is complete with four selected 1/16-in. panels of different coloured woods, 1/2-in. backing board and stripwood for border. There are also kits for trays inlaid in the same way and using larger panels of wood. Get Hobbies free pamphlet and learn more about Fretsaw Inlay. You'll be surprised how easy it is to create masterpieces in wood!

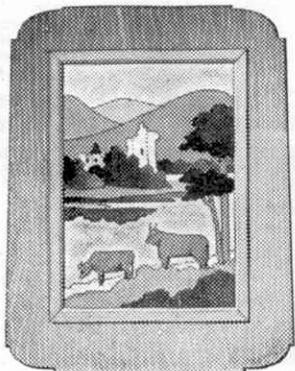

"Kilchurn Castle" (Kit No. 3008)

New designs for Fretsaw Inlay are published from time to time in "Hobbies Weekly," price 4d., every Wednesday.



To **HOBBIES LTD.**,
Dept. 96, Dereham, Norfolk.

Please send me, free of charge, your pamphlet on Making Pictures in Wood, and 20-page illustrated booklet "Profitable Leisure." Also send me the items I have marked thus **X**

KIT 3008
8/4, post free Specimen copy of "Hobbies Weekly,"
I enclose P.O. for..... 5d., post free

NAME.....

ADDRESS.....

BOND'S MODEL RAILWAY FITTINGS

Brass Solid Buffers. Gauge 00	0	1	
Wagon type ..	4d.	5d.	9d. each
Coach oval type with square base ..	5½d.	9d.	— each
	Gauge 0	1	
Brass Spring Buffers. Round head with square base ..	1/2	2/6	each
Oval head with square base ..	1/6½	2/10	each
	Gauge 00	0	
Brass Funnels. Standard type (L.M.S., L.N.E.R., G.W.R., S.W.R.)	1/-	1/6	each
Brass Domes. Standard types (L.M.S., L.N.E.R., S.R.)	1/3	1/9	each
Brass Ross Pop Safety Valves ..	6d.	6d.	pair
Alloy Wagon Axleguards. Super detail ..	5½d.	4d.	each
Brass Driving Wheels. White plated, for gauge 00 24 mm. or 26 mm. diam. ..			2/1 each
Brass Coach Bogies. Gauge 00, L.M.S. pattern ..		14/9	pair
Gauge 0, L.M.S. pattern ..		22/6	pair
Gauge 0, L.N.E.R. pattern ..		32/-	pair
Gauge 1, L.M.S. pattern ..		62/6	pair
Alloy Tender Axleboxes and Springs. Gauge 0 L.M.S. or G.W.R. ..		9d.	each
Brass Point Fittings. Gauge 0. Fork Joints 5d. each. Couplings 3½d. each. Rod Guides 3½d. each. Horizontal Cranks 8½d. each. Point Levers 3/- each. Postage and Packing extra.			
BOND'S CATALOGUES. Bond's Gear, Tool, Steam Fitting, Electric Motor and Material Catalogue, 1/6. Bond's Model Railway, Boats and Aeroplanes Fittings and Castings, 1/9.			
BOND'S O' EUSTON ROAD LTD. 357 EUSTON ROAD, LONDON N.W.1.			
Est. 1887 'Phone: Euston 5441-2			

THE BACK NUMBER SPECIALISTS CAN HELP YOU

Meccano Magazines	each
Before 1938 ..	1/-
1939-1943 ..	9d.
1944-1949 ..	6d.
1950-1952 ..	9d.
1953-Date ..	1/-
Model Railway News ..	Any
Model Railway Constructors ..	6d.
Model Engineers ..	each
Railways ..	each
Railway World ..	1/-
Railway Magazines ..	2/-
Trains Illustrated ..	1/6
Every Spotters' Weekly ..	6d.
Railway Modellers ..	1/-
Glossy P.C.s of Buses, Trams and Locos. ..	6d.
Cigarette Cards, 50 for 1/- or sets 1/6	

Write or call.

LENS OF SUTTON

50 Carshalton Road, Sutton, Surrey

ARE YOU INTERESTED IN RADIO?

Then build the amazing D.5.B. One Valve Receiver, ranges the Continent on a 22 volt battery, simple to build with our easy-to-follow diagrams. Highly instructive for the beginner in radio, will work anywhere with a short aerial and earth. Ideal for undisturbed listening, receives Luxembourg, Dutch, French, Italian, German and many other foreign stations. Fully detailed instructions and parts list sent for 1/6d. plus 1/4d. stamp. Send to:

OCEAN RADIO (Dept. M/M)
HIGH STREET, LUTTERWORTH, LEICS.



MECCANO MAGAZINE SELF-BINDING CASES

8/- Post Free

Magazines can be opened out flat and are easily read; held in position by metal strips passed through the stapling and slotted into the cover. Single copies can be

bound as received. Send P.O. to "M.M.", Binns Road, Liverpool 13.

CIGARETTE CARDS

SEND STAMP FOR COMPREHENSIVE LIST.

ALBUMS to hold 200 cards 1/9/-
100 different cards 2/9 post free.

MATCHBOX LABELS

INDIVIDUAL COUNTRY PACKETS.

All different.	12	25	50
Austria ..	1/6	3/-	6/-
Belgium ..	1/3	2/6	5/-
India ..	1/6	3/-	6/-
Italy ..	1/6	3/-	6/-

4 page list available price 3d. post free.

CHEESE LABELS

Send 1/3 for 16 page CATALOGUE.

25 different 1/9 50 different 3/-
75 different 5/- 100 different 7/6
200 different 15/-

E.H.W. LTD. (Dept. M), 12 SICILIAN
AVE., LONDON W.C.1 (150 yds. from Holborn Tube S.)



STUDY AT HOME AND PASS!

Wolsey Hall (est. 1894) can prepare you by post for all G.C.E. exams; London Univ. B.A., B.Sc., and many other exams. Moderate fees, instalments. Write for Prospectus to C. D. Parker, M.A., LL.D., Dept. GK91, WOLSEY HALL, OXFORD

Send a 3d. stamp for our new list of
**LINCRIFT de LUXE 1/72 SCALE
SOLID MODEL AIRCRAFT KITS**

which include all the latest jets and 1914 - 1918 aircraft. Complete in every detail. Nothing more to buy when you have a LINCRIFT kit.

WILMSLOW MODEL CO.

Water Lane, WILMSLOW, Cheshire

MECCANO MAGAZINE

Registered at the G.P.O., London, for transmission by Canadian Magazine Post.

EDITORIAL AND ADVERTISING OFFICES:

LIVERPOOL 13, ENGLAND.

Telegrams: "Meccano, Liverpool."

Readers' Sales and Wants. Private advertisements (i.e., not trade) are charged 1d. per word, minimum 1/-. Cash with order. Readers' advertisements are published as soon as possible; inclusion in the first issue after receiving them cannot be guaranteed.

READERS' SALES AND WANTS

SALES

"M.M.s" September 1923-October 1933 (six missing). Offers.—Cluff, 2 Beech Walk, London N.W.7.

"M.M.s" 1936-7, 1939-41 for sale, unbound, 9/- each year.—Maskell, 20 Holmwood Grove, London N.W.7.

150 "M.M.s", also Railway Encyclopædia, and many other Model Magazines and Books. S.A.E. list.—Phillips, 24 Derilwyn Road, Tondy, near Bridgend, Glam.

"M.M.s" year 1951 with exception of August, price 3/-, also S.E.L. Steam Engine in perfect condition 12/-.—I. Brunton, 19 Bellevue Gardens, Edinburgh.

Hornby-Dublo "Duchess" converted to two-rail operation. Shenphone split-potential Power Unit cost £19/19/-. Hand built detailed Pannier Tank Loco., two rail. Offers to—E. Kay, "Shalimar," Nyton Road, Aldingbourne, Chichester, Sussex.

"M.M.s" 1947-1953 unbound, 4/- per volume, except 1951 bound, 10/-. Excellent condition.—D. J. Munson, 28 Fairhaven Avenue, Shirley, Croydon, Surrey.

"M.M.s" 1944-1948; 1949 until August. Perfect condition, 5/- per year or 6d. each. Offers considered.—L. Marsh, 95 Osborne Road, Willesboro, Ashford, Kent.

"M.M.s" February 1947-December 1953. Perfect condition £3/10/- (postage paid U.K.).—Stiles, 292 Main Road, Gidea Park, Essex.

Johnson's Walt Disney Film Battery Projector with ten Films. All in excellent condition. £1 the lot.—Gates, 15 Second Avenue, Gillingham, Kent.

Comics: 280 "Dandies," 200 "Beans," 200 "Radio Funs," and 60 "Lions." Offers—Chapman, 165 Gipsy Lane, Birmingham 23.

"M.M.s" 1942/5/7/8, '50/1 complete, odd numbers other years. "Model Railway News," 1940/1. Odd numbers "Railway Magazine" and "Model Engineer." Offers—Elliott, c/o Cheyne, 371 Bath Street, Glasgow.

WANTS

Secondhand edition of "Reminiscences of G. P. Neele."—Hart, Park Bottoms, Gweck, Cornwall.

Super Model Leaflets, How to Use Meccano Parts, New Meccano Models, January, February, March, April 1953 "M.M.s" in good condition, state price.—J. Bates, 30 Dudley Road, Mission Bay, E.1, Auckland, New Zealand.

Prestacon Model Press, any condition.—E. Kay, "Shalimar," Nyton Road, Aldingbourne, Chichester, Sussex.

"Skybirds" or Dinky Toy Soldiers, particularly sitting or guncrews, Tanks, Field Guns, Searchlights, etc. Send details.—I. Douglas, 5 Bonnington Terrace, Edinburgh 6.

Super Model Leaflets, Instruction Manuals, any literature for pre-war Red-Green Meccano, also Meccano Steam Engine, details, price, etc. to—K. Ellender 17 Middleton Road, Ilkeston, Derbys.

THE MECCANO MAGAZINE

**You build it
strip by strip!**

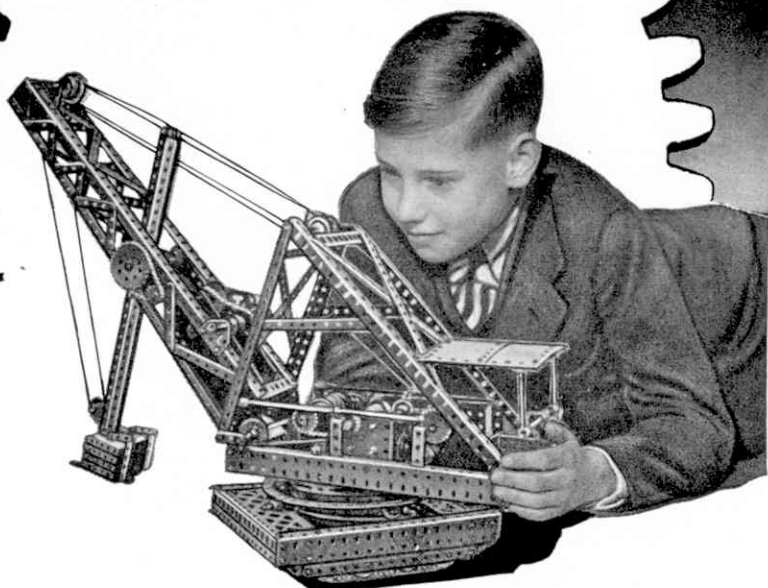

And when one fine working model is finished you can dismantle it and use the same parts to make another, even better. Accessory Outfits soon turn small outfits into big ones. The excitement of Meccano lasts . . . and lasts!

MECCANO

The Toy of the Century

MADE IN ENGLAND BY MECCANO LTD.

THE MECCANO MAGAZINE

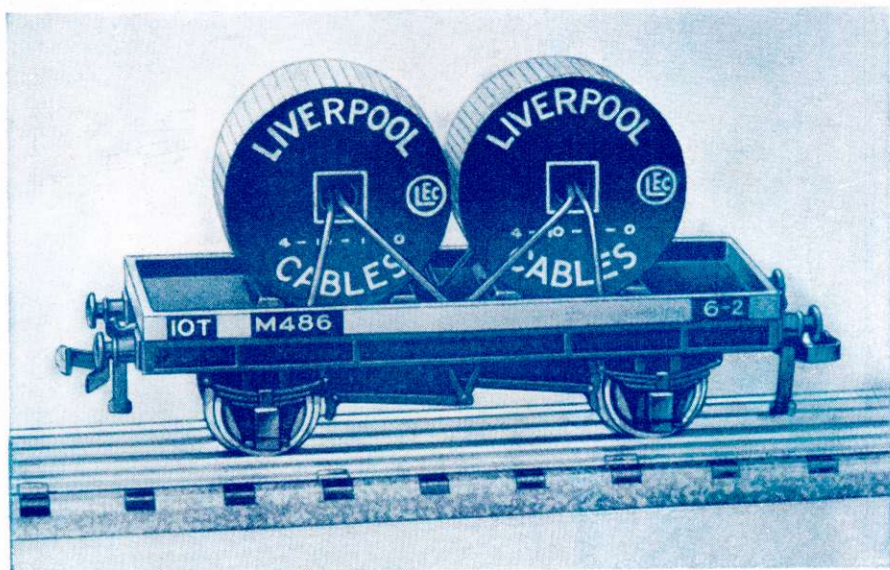

NEW

Hornby-Dublo Low-sided Wagons

... with and without Cable Drums

Above is a close-up of a new Hornby-Dublo Low-sided Wagon with Cable Drums, which will add to the variety and appeal of every Hornby-Dublo railway. The finish is in B.R. grey with white lettering on the usual black background.

PRICE 5/3 (including Tax)

Another version is available without a load. Similar in design, it has a plain floor, and can be used for many purposes. Hornby-Dublo owners will have plenty of fun devising suitable loads for this wagon which is finished in B.R. bauxite brown.

PRICE 4/3 (including Tax)

★ In the foreground of this Hornby-Dublo railway scene, a 0-6-2 Tank Locomotive is hauling a train of the new Low-sided Wagons.

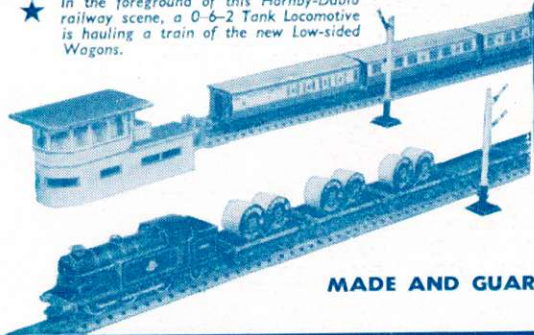

**HORNBY
DUBLO**
ELECTRIC TRAINS

MADE AND GUARANTEED BY MECCANO LTD.