

VOL. XLI. No. 11

NOVEMBER 1956

# MECCANO

## MAGAZINE



LIVERPOOL OVERHEAD  
RAILWAY

1/-

# DINKY SUPERTOYS

Dinky Supertoys are the 'big brothers' of Dinky Toys, and are produced in the same superlative quality.



No. 999  
D.H. Comet Airliner  
Wing Span 7½ in.  
Price 6/3

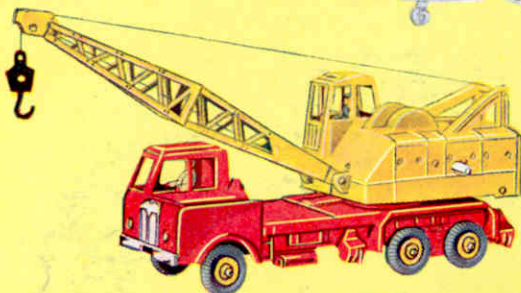

No. 972  
COLES  
20-ton  
Lorry-Mounted Crane  
Length 9½ in. Price 17/6



No. 934  
Leyland Octopus Wagon  
Length 7½ in. Price 8/-



No. 651  
Centurion Tank  
Length 5½ in. Price 7/11

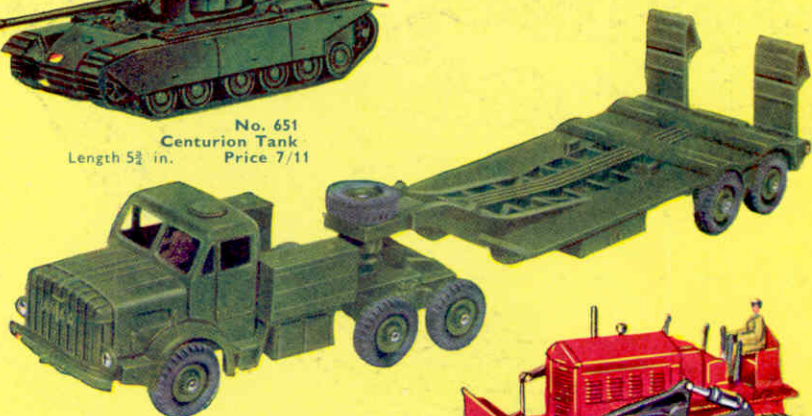

No. 660  
Tank Transporter  
Price 17/6  
Length with ramps lowered 13½ in.

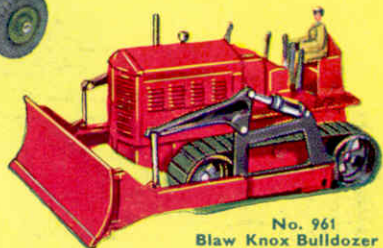

No. 961  
Blaw Knox Bulldozer  
Length 5½ in. Price 13/9

All Prices include Purchase Tax.

**MADE BY MECCANO LTD.**

# HORNBY DUBLO

## NEW Rolling Stock

Here are two excellent new models of British Railways rolling stock to add further realism to a Hornby-Dublo Railway. Both have long wheel-bases, with characteristic detail including brake cylinders, brake blocks and hangers. Fitted with automatic couplings. Tin-printed bodies.

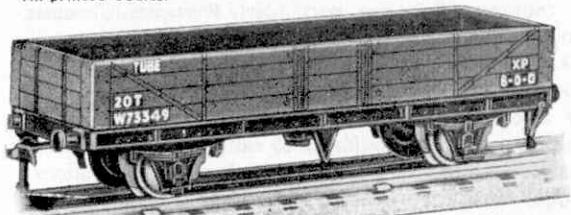

### 20-TON TUBE WAGON D1

This represents a wagon used for the carriage of tubes, pipes and similar articles. Length  $5\frac{1}{8}$  in. U.K. PRICE 6/- (inc. Tax)

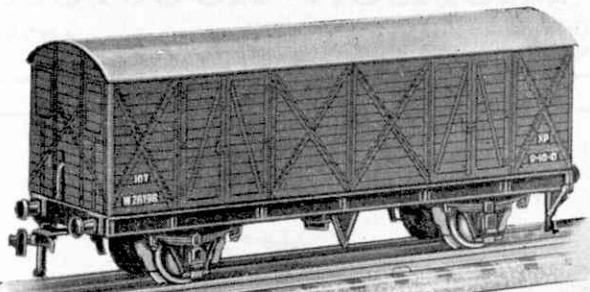

### VENTILATED VAN D1

This is a model of a vehicle used for carrying perishable goods of various kinds. Length  $5\frac{1}{8}$  in. U.K. PRICE 6/9 (inc. Tax)

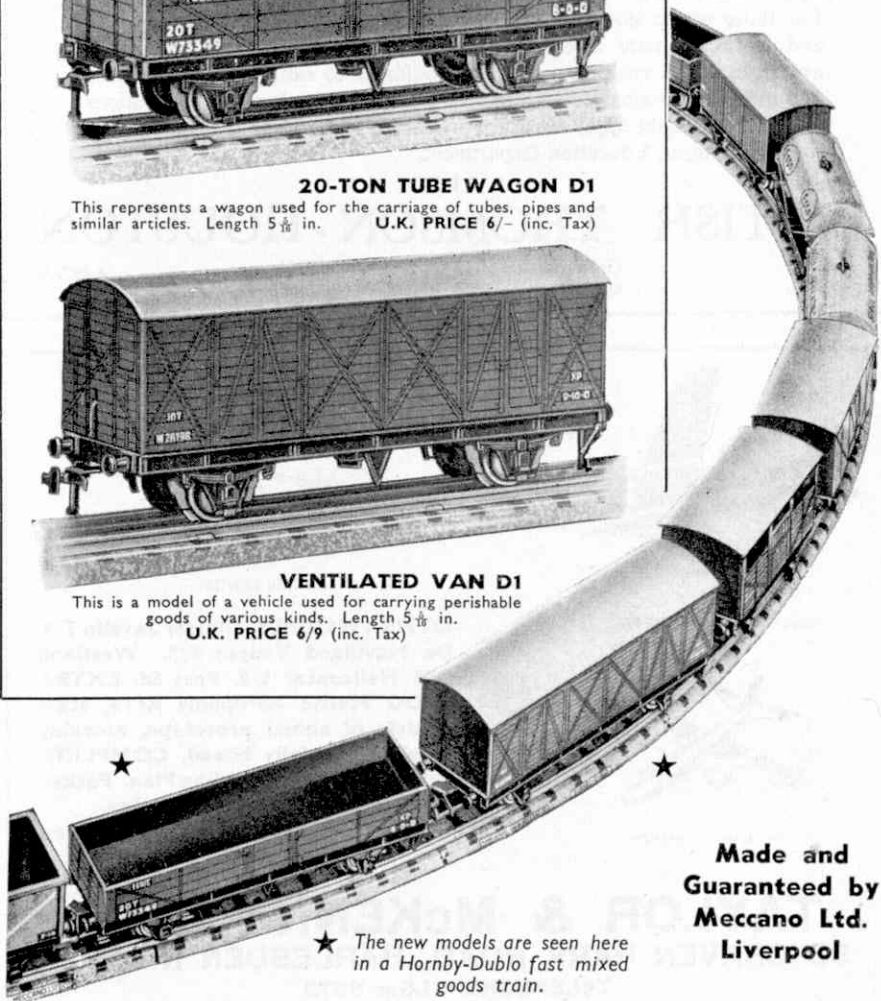

Made and  
Guaranteed by  
**Meccano Ltd.**  
Liverpool

★ The new models are seen here  
in a Hornby-Dublo fast mixed  
goods train.



**THIS TRADE MARK** is accepted throughout the world as a symbol of reliability and proved performance. It distinguishes the products of a large firm of electrical and mechanical engineers who have held, for over half a century, a position of leadership in British Engineering.



In keeping with the high standard of its products, the Company offers unrivalled facilities for the training of Scientists, particularly Physicists, Chemists and Engineers.

Apprentice courses are open to school-leavers from all types of Schools. For those with a good G.C.E. including passes in English, Mathematics, and an appropriate Science subject, a five-year "sandwich" course is available, which enables successful candidates to satisfy the examination and practical training requirements of the leading Professional Institutions. Candidates should apply for full particulars, mentioning this publication, to The Manager, Education Department,

THE

## BRITISH THOMSON-HOUSTON

COMPANY LIMITED, RUGBY

Members of the A.E.I. Group of Companies

A 4972 N

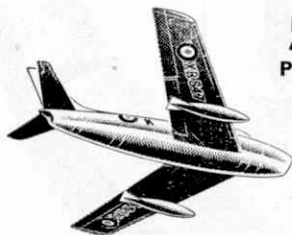

NORTH AMERICAN SABRE F86E

**5/3**  
Post 6d.

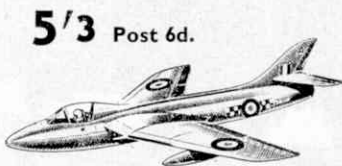

HAWKER HUNTER

**5/3** Post 6d.



ENGLISH ELECTRIC CANBERRA PR7

**8/6**  
Post 6d.

**OTHER MODELS.** Gloster Javelin 7/6. De Havilland Venom 5/3. Westland S.55 Helicopter 5/9. Post 6d. **EXTRA FROG Plastic Aeroplane KITS**, scale models of actual prototype, amazing detail, beautifully boxed, **COMPLETE** with Cement and Building Plan. Packed with display stand. No cutting. **The finest Plastic Kits on the market.**

(Please state second choice.)

**TAYLOR & MCKENNA LTD.**  
98 CRAVEN PARK ROAD, HARLESDEN N.W.10  
TELEPHONE: ELGar 3573



# Building with **BAYKO** is fun!



... because of the numerous models that can be built from a Bayko set, either from the plans provided or to your own design. The many detailed parts in each set give a realistic appearance to the models, which will satisfy the most critical juvenile architect.

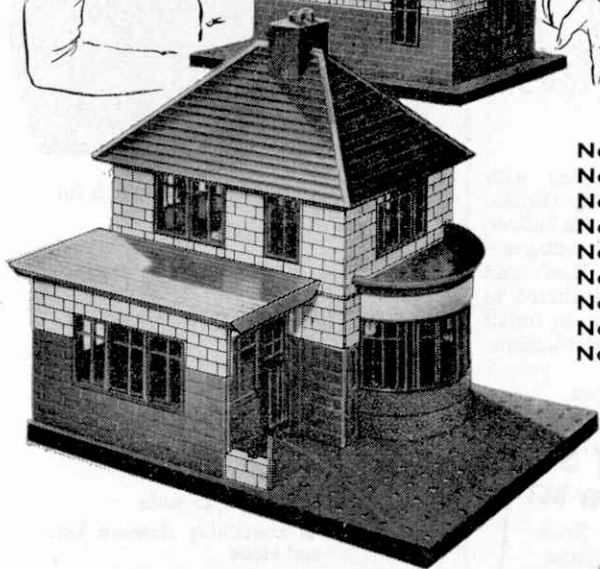

## PRICES

No. 0 Standard Set	..	14/-
No. 1 Standard Set	..	21/-
No. 2 Standard Set	..	31/6
No. 3 Standard Set	..	52/3
No. 4 Standard Set	..	99/3
No. 0X Converting Set	..	7/-
No. 1X Converting Set	..	10/6
No. 2X Converting Set	..	21/-
No. 3X Converting Set	..	47/-

# BAYKO

OBTAINABLE FROM LEADING  
STORES AND TOY SPECIALISTS

Manufactured by PLIMPTON ENGINEERING CO. LTD., LIVERPOOL 1.



# LOTT'S BRICKS

*-that's what we  
want for  
Christmas!*



Children everywhere love playing with LOTT'S Toy Stone Building Bricks. There's no end to the things you can build—houses, railway stations, farms and villages—all life-like and true-to-scale. Roofs and transparent windows are also included to give added realism. Supplied in sets for all ages complete with book of instructions. Ask for them this Christmas!

Prices from 7/2 to 59/6 per box.

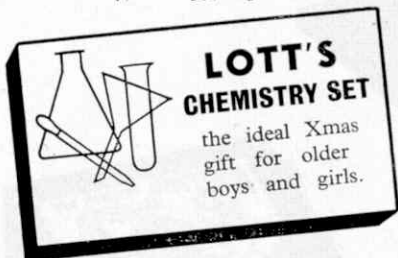

## LOTT'S CHEMISTRY SET

the ideal Xmas  
gift for older  
boys and girls.

Enquire of your Toy Dealer or write for price list of Sets and Spares enclosing stamped addressed envelope to:

**LOTT'S BRICKS LTD**  
(Dept. 23) WATFORD · HERTS

# Here's a Xmas Gift Idea!!!



*Indoor Photography can be such fun.*

*So ask for a*

## FLASHMASTER PRESENTATION OUTFIT

This attractive and colourful presentation  
comprises:

- Flashmaster Camera
- Coro-Flash Gun
- 120 size roll film
- Box Phillips PF 25 bulbs
- Wallet containing close-up Lens  
and Hood
- 2 Ever Ready Batteries

**Only 66/- complete**

Send 2½d. stamp for FREE BOOKLET

"Photography is Fun".

# Coronet LTD.

308 & 310 Summer Lane, Birmingham 19

# Start your collection NOW!

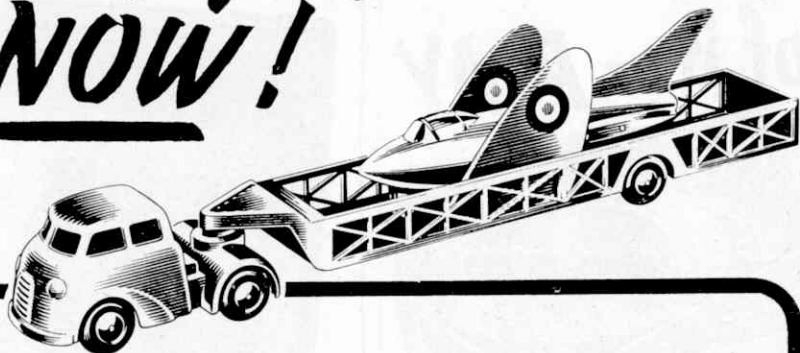

TRI-ANG MINIC PUSH AND GO:  
000 Mechanical Horse and Queen Mary  
with Jet aircraft. Price 5/-



TRI-ANG MINIC PUSH  
AND GO:  
000 Mechanical Horse and Low  
Loader with Tank. Price 4/6

Start your collection now with these new 000 Tri-ang Minic Push and Go Mechanical Horse series. True to scale models and just the thing to tie up with your Tri-ang Railway system.

## Tri-ang

Registered Trade Mark

# **PUSH and GO MINIC**

## **SCALE MODELS**

Obtainable from all good toyshops



# For the FUN of it - PLAY



## CAPPIT

A game for 2-4 players, who try to "Catch and Cap" their opponents. As easy as ludo, but much more exciting. **8/9**

## TELL ME

The queen of quiz games. Spin the wheel and roll out the questions! Endless fun for any age. Any number of players, the very thing for your party. **6/-**

Obtainable from good toyshops and departmental stores. If your dealer cannot supply, write for address of nearest stockist to:

**SPEAR'S GAMES**

**J. W. SPEAR & SONS LTD.**  
DEPT. M - ENFIELD - MIDDLESEX

## ELECTRIC CONTACT QUIZ



Best "Test your knowledge" game ever invented. For children 10 years onwards and grown-ups. Provides endless fun for your party and amuses children when alone. Complete with 12 quiz cards, but without battery, at good toy shops and stores. **12/11**

If your dealer cannot supply, write for leaflet and address of nearest stockist to:

**J. W. Spear & Sons Ltd., Dept. M, Enfield, Middx.**

## MODEL LORRY



**You can Dismantle it—Just like the real thing!**

Made up from 65 standardised parts—all replaceable.

Shaft drive. Universal coupling. Ackermann-type steering. Floating rear bogie. Rubber tyres. Powerful Spring Drive. Comes ready assembled.

### ★ DYSON 8-TON TRAILER

Attaches to rear of the FODEN LORRY. And dismantles in the same manner. **18/9**  
EACH

ASK YOUR DEALER TO SHOW YOU THESE WONDERFUL MODELS!

**ABBAY-CORINTHIAN GAMES CO.**  
LONDON S.W.1

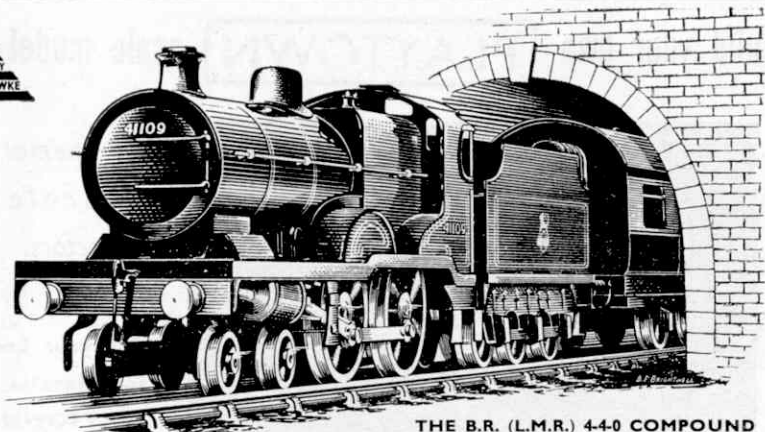

THE B.R. (L.M.R.) 4-4-0 COMPOUND  
Gauge "0". Clockwork or Electric.

## For indoor and outdoor model railways



### THESE ARE THE BOOKS

The Bassett-Lowke Model Railway catalogue and the Bassett-Lowke Shipping and Engineering catalogue are packed full of information and interest. From the smallest single job to the largest garden railway—whatever your interest you cannot afford to be without these famous books.

Write today to your nearest Bassett-Lowke branch for "Model Railways" (2/-) and/or "Model Shipping and Engineering" (2/6).

Whether you are limited in your resources and want one first-rate all-purpose locomotive or whether you are the owner-engineer of a system that carries several models on its busy tracks, you will be equally delighted with this powerful and reliable engine based on the original Derby Compound. NOTE: This is the model chosen by the B.B.C. for their television programme.

Clockwork No. 3302/O, £7.17.6. Electric No. 5302/O, £8.18.0. Complete gauge "0" sets—locomotive, rolling stock and track—are available at prices from £9.5.0.

Don't miss this. A special leaflet on the B.R. Compound (containing notes on model railway construction generally) will gladly be sent to you free.

# BASSETT-LOWKE LTD.

Head Office and Works: **NORTHAMPTON**

LONDON SHOWROOMS: 112 High Holborn, W.C.2 MANCHESTER SHOWROOMS: 28 Corporation Street, 4

# Build your own **PLAYTOWN** scale model village!



*Of special interest  
to scale model  
collectors.*

Ask your Local Dealer  
for details of these  
**PLAYTOWN** sets  
at prices from

## 4'11<sup>d</sup>.

PLAYCRAFT TOYS LTD., 120 MOORGATE, LONDON E.C.2

## **NEW!** EXPERIMENTAL OUTFITS

### LEARN THE PRACTICAL WAY

Here is home study of the most effective kind under expert tutors. There is no better way of studying for an examination, a career in industry or starting a new hobby. These special courses comprise the most modern methods of postal tuition, combined with a Practical Outfit (which remains your property).

Courses with practical equipment include:

Radio, Television, Mechanics, Electricity, Chemistry, Photography, Carpentry; also Draughtsmanship, Commercial Art, Amateur S.W. Radio, Languages, etc.



**POST THIS COUPON TODAY**

#### To E.M.I. INSTITUTES

For FREE brochure write to:  
Dept. 197X, Grove Park Road, London, W.4.

Subject(s) of interest .....

NAME .....

ADDRESS .....

NOV. .... I.C.51a

**COURSES FROM 15/- PER MONTH**

## **EMI INSTITUTES**

An Educational Organisation associated with the E.M.I. Group of Companies which include:  
"HIS MASTER'S VOICE", COLUMBIA, Etc.



# YOU TOO CAN PLAY TEST MATCH CRICKET!



- Watch the score board figures rolling round as the runs mount up!
- Feel the excitement as the batsman prepares to receive a googly!
- Will your last wicket be able to avoid the "Follow-on"?

Buy the new game "Test Match" and these and all the other excitements of test match cricket will be yours.

**15/0d. Complete**

(including purchase tax)

From all Stationers, Stores, etc.

Made in England by the Makers of Monopoly—  
**JOHN WADDINGTON LTD., LEEDS & LONDON**

**NEW****POWER CONTROL UNIT A2**

A safe, reliable, self-contained Power-Unit, with one pair of output terminals, providing low voltage D.C. output.

The Unit has a die-cast case that makes it practically indestructible. It includes a transformer, which is proof against short circuiting and so cannot be harmed by overloading, with a full wave rectifier and a controller. An indicator lamp gives immediate warning if a fault arises in the circuit connected to the Unit.

**For use on Alternating Current Mains ONLY**



**INPUT** 220/250 volts 50/80 cycles 14 watts  
(Non-standard voltages to special order)

**OUTPUT** D.C. 0-12 volts 8 watts (variable)

**Price** £2/12/6

Next Month: "A NEW ZEALAND GOLD RUSH"

# MECCANO

## MAGAZINE

Editorial Office:  
Binns Road  
Liverpool 13  
England

EDITOR : FRANK RILEY, B.Sc.

Vol. XLI  
No. 11  
November 1956

### An Historic Electric Line

On page 554 is the story of the Liverpool Overhead Railway, told in brief. This famous line, the first overhead electric railway ever built, has been struggling against fate for some time, but now it

present year, unless at the eleventh hour some scheme for ensuring its continuation is devised. This does not seem likely, and indeed at the time of writing steps are being taken to provide buses to carry passengers

along Liverpool's dock road, which runs parallel to its course. I suppose these will carry efficiently the people whose business takes them along that road, but they will add seriously to traffic congestion on a famous highway already busy with heavy traffic to and from the docks—and no bus service can possibly give passengers the views provided on the Overhead Railway, with its thrilling glimpses of shipping in the docks and on the Mersey.

#### The Christmas M.M.

Now let us turn to something more pleasant, the Christmas *Meccano Magazine*. As is customary, this will be larger than the average issue, and its contents will be widely varied. The cover will have a traditional Christmas air, and inside there will be contributions with a Christmas flavour as well as a host of others of the kind that readers enjoy. The scenes in which these are set range from Finland to Mexico, Australia and New Zealand, as well of course as over Great Britain. No increase in price!

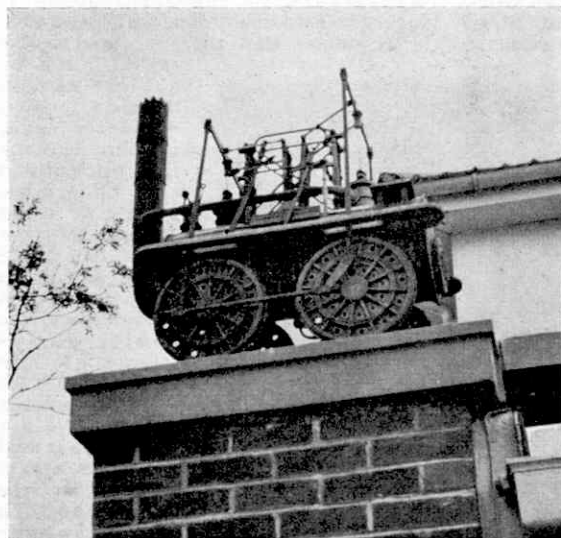

Although the steam locomotive is giving way to diesels and diesel-electrics, the iron horse will not be forgotten. One reminder that may last for many years is this novel inn sign in Newton Aycliffe, photographed by T. Pearce, Nunthorpe, a 10-year old reader. It shows "Locomotion," the steam locomotive built by George Stephenson for the Stockton and Darlington Railway, which was placed on the line at a level crossing in Aycliffe Lane in September 1825, shortly before the opening of that historic railway.

seems as if it will have to go, after years of valuable service.

The closing of any railway line is regrettable, but the end of the Liverpool Overhead is in its way a tragedy. Trains will cease to run on it at the end of the

and New Zealand, as well of course as over Great Britain. No increase in price!

*The Editor*



# A New Era

## The Opening of The Calder Hall Power Station

By the Editor

**A** FORTNIGHT ago H.M. The Queen officially opened Britain's first nuclear or atomic power station at Calder Hall, in Cumberland. This was a really momentous event. A small power station generating electricity from nuclear fuel has been working in Russia for some time, but Calder Hall now supplies substantial quantities of electricity to the distribution system of the Central Electricity Authority, and is the first station of its kind to contribute on this scale to a national system.

Some details of the construction of the Calder Hall station were given in an article in the *M.M.* for June of last year. Now I am able to illustrate the station itself, in

to be six months later than that of the first.

In the picture the hall in which are the turbines that drive the generators is to the right of the reactor, and on its left are two great structures that every reader will recognise at once as cooling towers.

The energy produced in the reactor comes from the fission, or break up, of the atoms of uranium 235 when bombarded by neutrons. This starts what is called a chain reaction, for more neutrons are released during the break up, so that the whole action rapidly speeds up, developing tremendous energy. This makes its appearance in the form of heat, an enormous amount of which is generated.

At Calder Hall the heat produced is carried away by the gas carbon dioxide, which circulates under pressure through the reactor and then through the tubes and passages of heat exchangers. In the latter, part of its heat is transferred to water, and the cooler gas is returned to the reactor. The steam produced in the heat exchangers is used to drive steam turbines of the type used in normal power stations where coal is burned to provide the energy, and in turn the turbines drive alternators to

yield electricity. The generating equipment consists of four 23,000 kW. turbo-alternator sets, two for each reactor.

The reactor itself is a very large and heavy structure. In it are thousands of carefully machined graphite bricks, surrounded by tons of steel plates 6 in. thick and an octagonal concrete wall

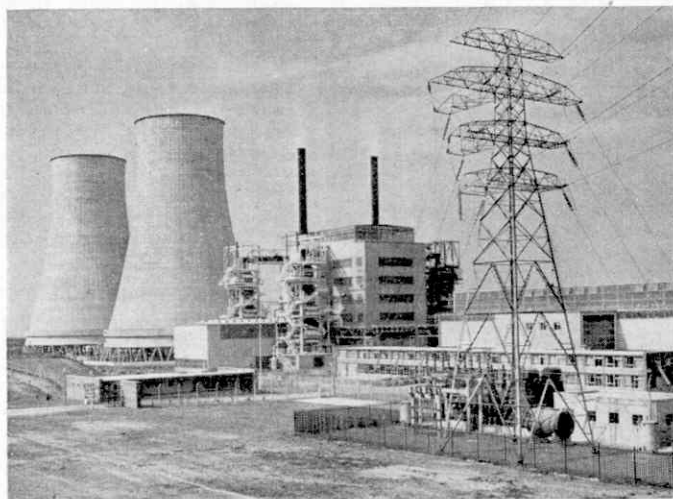

Calder Hall, Britain's first nuclear power station, which was opened by H.M. The Queen on 17th October, 1956. It is the first in the world to supply substantial quantities of electricity to a national system.

the picture on this page. The reactor, the device in which the atomic reaction involved is carried out, is in the centre of the picture. When complete Calder Hall will have two reactors, and the second was undergoing technical tests at the time the photograph reproduced was taken. The progress of this second reactor was planned

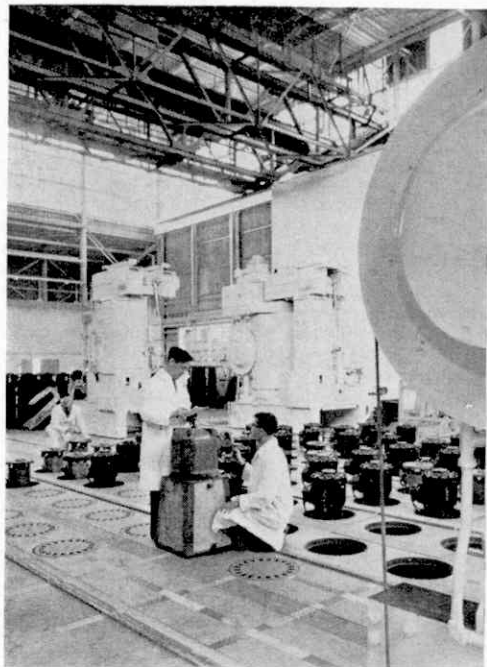

The charge-discharge deck of No. 1 reactor of the Calder Hall A atomic power station. Rear-left can be seen a lightly shielded charge machine and in the rear centre is a heavily shielded discharge machine, both devices used to insert new fuel cartridges and remove highly radioactive spent cartridges from the reactor.

80 ft. high. The uranium fuel elements and the control rods for the reactor are placed in vertical channels in the graphite.

The very greatest care had to be taken in building the plant to keep everything scrupulously clean. Otherwise there was always the possibility of dirt from say the tubes in the heat exchangers being carried by the circulation of the carbon dioxide into the reactor, with a reduction in its efficiency. Other precautions included designing the heat exchangers so that all welds on the tubes after they had been erected were outside the vessel itself. This was to keep down the risk of leakage of water.

The production of electricity

by nuclear power is indeed being developed at a very convenient time, in view of the fact that coal production in Great Britain has fallen behind requirements, so that the country is actually importing coal, instead of exporting it, as was the practice in the past. Other stations in various regions are planned, and it is expected that by 1975 they will meet 40 per cent. of our requirements of electric power, the demand for which will then be much greater than today.

A ton of uranium is in theory equivalent to about 3,000,000 tons of coal. Even if only a third of the heat developed in reactors can be put to use in generating power, that still leaves a ton of uranium equivalent in practice to 1,000,000 tons of coal. Now we know that there are 1,000,000 tons of uranium in the Earth awaiting extraction. This is enough to last us for a very long time indeed, and there are no doubt other uranium resources not yet known, while other radioactive elements also may be used.

The prospect indeed is far more comforting than that. The kind of atomic power station so far thought of, and now for the first time brought into use on a reasonably large scale by the opening of Calder Hall, makes use of fission, that is the break up of radioactive atoms, as the source of power. In this respect it may be thought of as comparable with an atomic bomb of the kind used at Hiroshima and

*(Continued on page 596)*



This picture shows preparations being made to insert uranium rods at the top of the first of two piles at the Calder Hall atomic power station. The first of these piles has now started working.

# New Zealand's Rail-Air Service

By John W. R. Taylor

**A**LTHOUGH we hear almost every month of some strange new job being done by aeroplanes somewhere in the world, I must admit that I was shaken when an *M.M.* reader in New Zealand told me recently that even railway wagons go by air in his country.

As you probably know, New Zealand is made up of two main islands, separated by 16 miles of water known as the Cook

away on the South Island is Woodbourne airfield, within four miles of Blenheim Station on the main line to Christchurch.

A six-day experimental airlift between Paraparaumu and Woodbourne by Dakotas of the R.N.Z.A.F. in December 1946 was so successful that a regular Dakota Rail-Air service was opened in conjunction with the New Zealand National Airways Corporation in the following year. But the

"Dak" was designed as an air liner and when Bristol's demonstrated one of their Freighters on the service it was obvious that this aircraft, with its big nose-loading doors and capacity of six tons, was the real answer to the problem of airlifting heavy, bulky freight loads.

So it was that in February 1951 Straits Air Freight Express (S.A.F.E.), a subsidiary of the British Airwork independent airline, were given a contract to take over the Rail-Air service using two, and later



Mixed general freight being loaded "en bloc" into an aircraft of Straits Air Freight Express, New Zealand.

Strait. Because of this, the New Zealand Railways (N.Z.R.) system is split into two sections, with 1,688 miles of track on the North Island and 1,800 miles on the South Island.

Until 1946, goods consigned by rail between places on the two islands were carried across the Cook Strait by ship. But so many vessels had been sunk during the war that delays became more and more frequent and lengthy. Finally, it was decided to see if air transport could be used to speed up the service.

There was no difficulty in finding airfields, because the important North Island aerodrome at Paraparaumu is only six miles from the railway station at Paekakariki, which is 30 miles from Wellington and has a large warehouse where goods can be sorted. A mere 72 miles

three Bristol Freighters.

One of the factors that earned S.A.F.E. the job was their suggestion for a new loading and unloading technique to speed turnround time. Realising that the size and shape of load carried by a Freighter is much the same as that carried by railway wagons and lorries, they suggested packing each aircraft load—whether it consisted of large units such as motor cars or of hundreds of small packages—on to a pair of removable wheeled trays called "Cargons" which could run on rails mounted inside the aircraft's freight hold.

Right from the start, this Cargon system proved a tremendous success and today it is being used by Australian National Airways for their service across the Bass Strait as well as by S.A.F.E. Goods for S.A.F.E.'s Rail-Air service are simply

packed on to a Cargon and taken by lorry and trailer to Paraparaumu or Woodbourne, at each of which the N.Z.R. have two special loading decks called traversers to speed transfer of the loaded Cargons from lorry to aircraft and *vice versa*.

These traversers are simple enough.

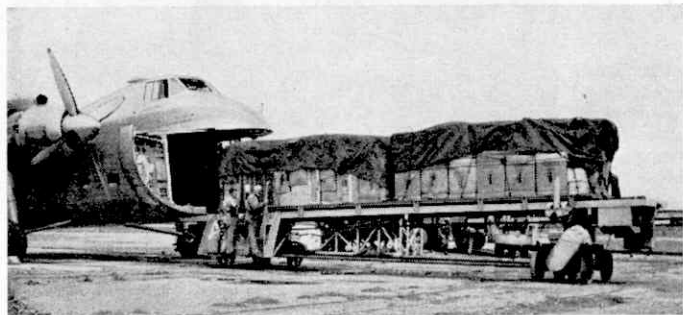

A load of general freight on the long platform, or traverser by which it is passed into the aircraft.

Each consists of a 40 ft. long platform mounted on a pair of four-wheel bogies so that it can be driven electrically along standard railway tracks. It can be raised or lowered at each end to line up with the tailboard of a lorry or the cargo hold of a Freighter, and has a motorised endless chain running down its centre.

For loading, the traverser is first lined up with the lorry so that the Cargons can be hooked on to the endless chain and, at the push of a button, dragged from the lorry on to the deck. The traverser then runs along the rails until it is in front of the aircraft, its end is levelled and the Cargons are fed into the Freighter's cabin in the same way.

Loading can be done by one man with a lorry and two trailers in 12-14 min., compared with six men, two lorry-trailer units and up to 90 min. for hand loading. On average, the Freighters can be ready to take off with another load within 20 min. of landing.

Money is saved as well as time, because the fact that loads are pushed in as a complete unit on a

Cargon reduces handling of individual items, which can be sent with a minimum of expensive protective packing. Cars, refrigerators, eggs, sheep, frozen foods, fruit and furniture are flown regularly. So are racehorses, which are carried eight at a time in specially-designed lightweight

boxes, complete with their trainers and sufficient fodder to last until they return again to their home stables. They certainly appear to enjoy the ride, because the 70 horses carried in 1954 won over 30 races and came second or third in many others.

When the operations were extended to include occasional

services to Nelson and Oamaru both on South Island, it would have cost too much to equip these terminals with traversers. Instead, the tail of the aircraft is simply jacked up after landing and the Cargons are hauled out on to wheeled trolleys. This takes longer than the traverser method, but is very much quicker than hand loading.

Needless to say, the aircrews of S.A.F.E. and the men who handle the Rail-Air cargoes on the ground are always keen to find something new to carry. Their proudest load was a 5-ton road grader measuring 20 ft. long, 6 ft. 6 in. wide and 6 ft. 9 in. high, until they heard about

(Continued on page 596)

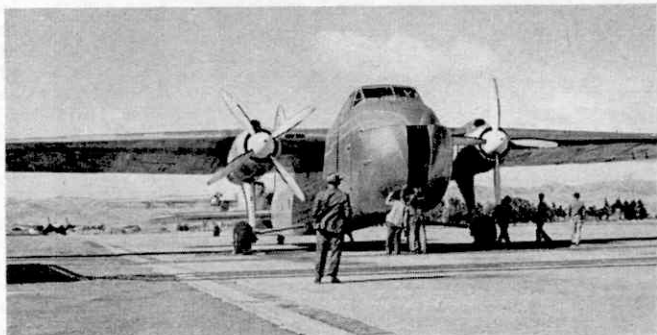

One last look at the load inside before closing the huge doors in the nose of the S.A.F.E. Bristol Freighter.

## Road and Track

By Peter Lewis

THE Italian Grand Prix was one of the most exciting races I have ever seen, and one which gave a tremendous fillip to British prestige. We had the victory of Stirling Moss, the excellent performance of Schell's Vanwall and the highly creditable third place of the Connaught driven by Ron Flockhart.

It occurred to me, as we watched Flockhart helped out of his car by the jubilant Connaught *equipe*, that you might like to know something about this quietly spoken native of Edinburgh, whose skilful handling of the lone Ecurie Ecosse Jaguar at Le Mans and Rheims earlier this year established him securely as one of our foremost sports car drivers.

Although he looks a young man—most people think he is in the early twenties—he is, in fact, thirty-three years old and was serving with the 8th Army in the latter stages of the Italian campaign, when Stirling Moss and Mike Hawthorn were still schoolboys.

Understandably—for he took a degree in Engineering at Edinburgh University in 1943—2/Lt. Flockhart was posted to R.E.M.E., ending up a Captain in the



Ronald Flockhart receiving congratulations at Monza. Photograph by courtesy of Motor Racing.

hard-hitting British 6th Armoured Division, his war service was by no means lacking in action. However, with service motor-cycles at his disposal—which he rode with great verve on the challenging Italian roads—he did not hesitate, as he puts it, to “organise a trial every now and then to pass the time away.”

After the war, a miraculous escape near Hatfield when the rear wheel of his motor-cycle locked solid at 80 m.p.h. and only his skill averted disaster convinced him that four wheels were safer than two. Later he bought an M.G. T.C. In spite of various successes with this, and with a J.P. 1,000 c.c. racing car powered by a Vincent Black Lightning engine, it was an immaculately turned out blue E.R.A. (R.4.D.) that made the motor racing enthusiasts sit up and take notice. He and his car were a perfect combination. He still has a great affection for it. He stripped it down to the last nut and bolt during the winter months preceding the 1953 season and then rebuilt it. His conscientious painstaking preparation paid handsome dividends, for out of fifteen races in 1953 R.4.D. only failed to finish in two and was either 1st, 2nd or 3rd in the remainder. Six times it recorded fastest lap or a new lap record.

Many times I have commented on



Juan Fangio—again World Champion.



Flockhart's handling of the D. Type Jaguar. He looks absolutely at home . . . a perfect combination of man and machine. He gave me the answer. "The D. Type is very similar in handling characteristics to R.4.D."

Now Flockhart has his own Auster aeroplane, which is kept at Wolverhampton, where he is with the local Austin agents. He flew to Monza for the Italian Grand Prix this year, and finds the Auster most useful when B.R.M. want him for testing at Folkingham or Silverstone.

I asked him about Le Mans, and what he dislikes most about the race. His answer: "The right hand sweep upwards under the Dunlop Bridge, which is taken at over 100 m.p.h., is a problem demanding maximum concentration, and at night the brilliantly lighted sideshows flanking the Esses series of bends are disconcerting."

Just before he settled down in the driving seat of his blue Austin-Healey 100.S. I asked him how he relaxes when he is not at the wheel of a racing car, a D. Type Jaguar or a Lotus sports. Not surprisingly for he is an intensely patriotic Scot, he told me that he likes walking in the colourful Western Highlands. When he cannot get there he plays golf or reads in his spare time. Modest, knowledgeable, and with a steady yet forceful approach to the sport, Ron Flockhart will—I am sure—have many more successes.

### Juan Manuel Fangio

After the Monza race, I talked with Stirling Moss about Juan Fangio, Champion Driver of the World for the fourth time. I asked Stirling—for he knows Fangio as well as anybody—what it is that makes the forty-four year old Argentine a *far* better driver than most and a better one than the select few in the top class.

Stirling did not find my question an easy one to answer, but of one thing he is certain. "It is the mind that is the key to success in motor racing and Fangio has such phenomenal control over his mind that he can successfully combat mental fatigue. He keeps his mind on the job to such an extent that he and his car make a maximum effort from start to finish of a race." Stirling considers that Fangio has two other great qualities.

"He has tremendous determination and absolutely refuses to admit defeat. And to put it bluntly—he has more courage than almost any other man I know, whatever their walk of life."

So there we have the qualities of a champion—apart, of course, from his superb skill. Will power, determination and courage.

### The Veterans

There is one Sunday in November every year when I have an appointment that I would not break—not even for a Grand Prix. It is the day—Sunday, 4th November this year—when that impressive and majestic cavalcade of veteran cars makes

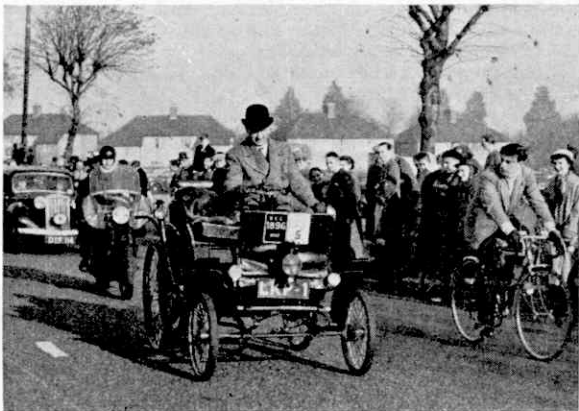

L. Lewis-Evans driving an 1896 dog cart, fitted with a 3½ h.p. Benz engine.

its way from London to Brighton.

On several occasions I have travelled in a veteran as a passenger. But this year I shall watch the procession of over two hundred cars, none manufactured after the end of 1904, from the dual carriageway near Crawley, Sussex. These magnificent machines, with their spotless engines, shining brass headlamps and perfect unscratched bodywork are not museum pieces by any means and certainly not "old corks." Many carry G.B. plates—mementos of post-war rallies to France, Belgium, Holland, Norway and Denmark.

Why not find a good vantage point, buy yourself an official programme, and spend a fascinating hour or so watching a convincing demonstration of craftsmanship and reliability. For it is a fact that the majority of the veterans are more reliable and run better to-day than when built.

The Run starts at 7.30 a.m. from Hyde Park.

# A Liverpool Landmark

## The World's First Electric Overhead Railway

NO traveller from overseas, disembarking either at the Liverpool Landing Stage or in any of the docks along the six-mile river front, can leave the port without passing beneath the girders of the Liverpool Overhead Railway, known familiarly to the citizens as *The Dockers' Umbrella*. This unique line fills an important role in the mass transportation of all whose business takes them to the vicinity of the docks on the Liverpool side of the Mersey, and crowds of visitors ride on the line to enjoy the wonderful views of the docks and shipping that can be obtained from its carriage windows.

As far back as 1852 traffic congestion on the Liverpool Dock Road provoked discussion of a scheme for an elevated railway, but nothing definite was done until 1888, when the late Sir William Forwood and other prominent citizens promoted a company that assumed powers previously obtained by the Mersey Docks and Harbour Board. Construction went ahead, novel methods being adopted in erecting the bridgework without interference to the heavy traffic at surface level.

The first section was opened between the Herculaneum Dock in the south and Alexandra Dock in the north on 6th March 1893. In 1894 the bridgework was extended north to Seaforth Sands, where carriage works were built, and this extension was opened on 30th April. At the southern end the line was extended to Dingle. A passenger who had never seen the railway and entered a train there would think it strange that he should begin his journey on an overhead railway by going underground. Yet this is so, for the first half mile from Dingle terminus is in a tunnel.

The Dingle extension was opened on 21st December, 1896, and this completed the railway. But Overhead trains run daily between Seaforth Sands, the northern terminus, and the station called Seaforth

and Litherland over British Railways metals that originally were part of the Lancashire and Yorkshire system. For some years a service also was operated between Southport and Dingle, with special lightweight rolling stock built by the Lancashire and Yorkshire Railway to comply with restrictions on the weight of vehicles travelling on the overhead section.

Once a year, on Grand National Day, a service of Overhead trains has been operated through to Aintree from Dingle



James Street Station on the Liverpool Overhead Railway, from the platform of which the view on the cover of this issue can be seen. Photograph, Central Office of Information.

and intermediate stations. Along one short section near Seaforth Sands, only traversed by electric trains on the day of the Grand National, the passenger was invariably treated to a vivid display of arcing, caused by the deposit of rust on the third rail.

The bridge structure of the Overhead Railway consists of wrought-iron girders

spaced 22 ft. apart, with a height of 16 ft. and a normal span between the supporting columns of 50 ft. The columns consist of two steel channels and two plates. At Langton, Sandon, Brunswick and Stanley Docks opening bridges are provided so that out-of-gauge loads can enter the dock estate. The bridge at Stanley Dock—the only dock on the landward side of the railway—is a double-deck structure carrying both the Overhead Railway and the Dock Railway, which is at street level.

The track of the Overhead consists of light, flat-bottom rail laid on longitudinal timbers, and is unballasted. Current collection is by means of an outside third rail, but in its early days the third rail was situated between the running rails. This was altered to conform to Lancashire and Yorkshire practice when through running between Southport and Dingle was inaugurated.

From the very beginning the Railway has been protected throughout by automatic signalling, which was modernized later on by the adoption of colour-light signals that are clearly visible from a distance of 3,000 feet in the brightest sunlight. It is interesting to note that the Liverpool Overhead Railway was the first in the

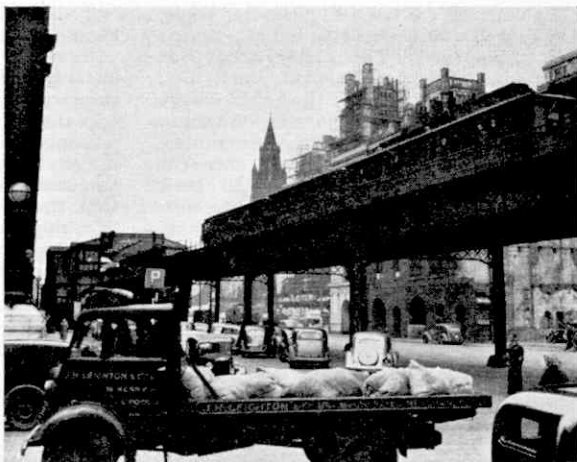

A typical view of the Overhead from street level, showing a standard three-car train making its way along the elevated structure. Photograph, Central Office of Information.

country to adopt automatic colour-light signalling throughout, and it has a wonderful record of safe operation. It was also the first electrically operated elevated railway in the world, though steam traction had been considered.

At Bramley Moore Dock the line descends to street level to enable it to pass beneath railway sidings and coal tips, and on this short switchback section the track is ballasted in the normal way, the rails being laid on transverse sleepers as in normal railway practice. The tunnel section at Dingle also is ballasted.

Trains originally consisted of two cars. Later on three-car sets were used, and these continue to operate to-day. The vehicles are short in order to negotiate the sharp curves and are equipped with transverse seats and centre gangways. Both first and third-class accommodation is provided. Entrance and exit is by means of swinging doors. There is through communication between the coaches, but this is used by railway staff only.



One of the rebuilt trains of the Overhead Railway, in the Works at Seaforth Sands. Photograph, Liverpool Overhead Railway.

Each motor car has a single motor bogie, and spoked wheels are fitted to both driving and trailing cars. The original stock was built by Brown, Marshall and Co., Birmingham, and some of the vehicles have matchboard sides in the old American fashion. In 1947 a rebuilding programme was commenced, and several three-car trains have been dealt with. In their rebuilt form the vehicles have power-operated sliding doors, upholstered seating, and large windows giving an unobstructed view of the passing scene. The coaches are

**e x t r e m e l y**  
comfortable and  
**c o m p a r e**  
favourably with  
modern vehicles  
elsewhere.

Although the Overhead Railway has been electrically operated throughout its existence, it did possess for many years a steam 0-4-0 well tank locomotive, built by Kitson's of Leeds. This was used for ballast and material trains. This engine, known as *Lively Polly*, was sold a few years ago on being replaced by a diesel, and now works at Monks Ferry coal wharf, Birkenhead.

There are seventeen stations along the six and a half miles of track, most named after docks, with four exceptions. They are reached from street level by stairways. One of the first escalators in the country was installed at Seaforth Sands as long ago as 1900, but eventually was abolished. A lift is now used at this station during rush-hours.

It is curious to recall that for some years the Company operated a street tramway extension, from Seaforth Sands to Great Crosby. This was discontinued in 1925. The route is now worked by Ribble Motor Services Ltd. The trams carried the title *Liverpool Overhead Railway* on their rocker panels and ran in a pleasing livery of green and cream. All traces of this system have disappeared except for a few poles used for lighting, and a short piece of track still

embedded in the paving just outside the booking office at Seaforth Sands Station.

A trip on "The Overhead" is essential if one is to appreciate the extent of Liverpool's shipping and dock traffic, and cheap round-trip tickets are available every day. The passengers mingle with men of a great many nationalities, and so great a variety of languages can be heard in the one carriage that the line is often referred to as the "Cosmopolitan Railway."

As the train proceeds the panorama of dockland activity unfolds rapidly before the

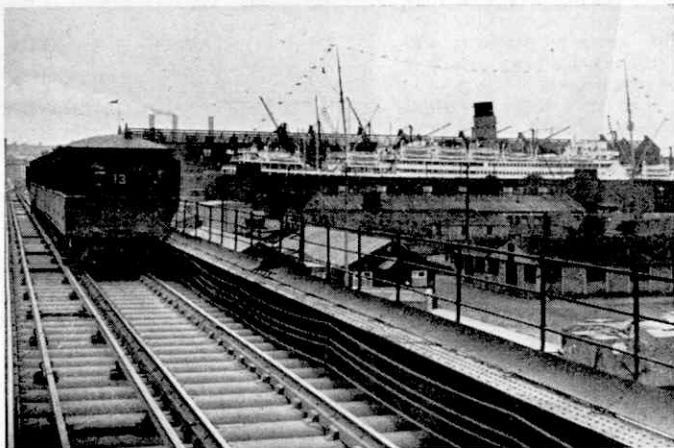

A trip along the Overhead provides a grandstand view of Liverpool dock activities. This illustration gives a very good impression of the Overhead Railway permanent way. Photograph, Central Office of Information.

eyes, with huge warehouses and other buildings sometimes closing in on the line so that the trains appear to be running in the dark depths of canyons. Ships of all sizes and nations are seen in the docks, with an amazing variety of cargo piled up on the quays and roadways.

Now and again a billow of steam and the muffled clanging of bells from beneath the train denote the presence of one of the fleet of dock steam locomotives busily engaged in shunting or hauling wagons between the dock estate and one of the B.R. goods depots. The main line of the dock railway runs beneath the girders of the Overhead. At one point, at the foot of James Street near the Pier Head, one can see almost every form of transport in the space of a few minutes—overhead trains, surface trains, trams, buses, cars, lorries and ships, not to mention bicycles, horse-drawn

(Continued on page 596)

# Highlights of Farnborough, 1956

By John W. R. Taylor

**M**ANY people expected this year's S.B.A.C. Display at Farnborough to be a dull parade of the same old aeroplanes that we have seen time after time, because there were no entirely new prototypes in the flying programme. Yet, for me at least, it was one of the most satisfying shows since the war.

The star performers were, perhaps, the two Fairey Delta 2's, one of which carried on its needle-nose an orange flash to identify it as the aircraft that holds the

at Farnborough. It was mostly hidden inside the bomb-bay of the Canberra flying test bed, but the harsh roar and bright orange shock-wave diamonds of its twin exhaust flames gave a hint of tremendous power.

Also from Napier's was a new rocket boost system built into the rotor tips of the tiny Saunders-Roe Skeeter helicopter and supplied from a tank of high test peroxide fuel above the rotor head. Each rotor-tip motor is small enough to carry in the palm of one's hand, yet the system increases the Skeeter's vertical rate of climb from 230 ft./min. to 1,400 ft./min.

Rockets of a very different type were the Fairey Fireflash air-to-air guided missiles which, despite their size, seemed to have no effect on the speed or manoeuvrability of the Hunter F.4 and Swift F.7 fighters under the wings of which they were carried. They were the only fully-developed guided missiles on show; but there was an English Electric rocket suitable

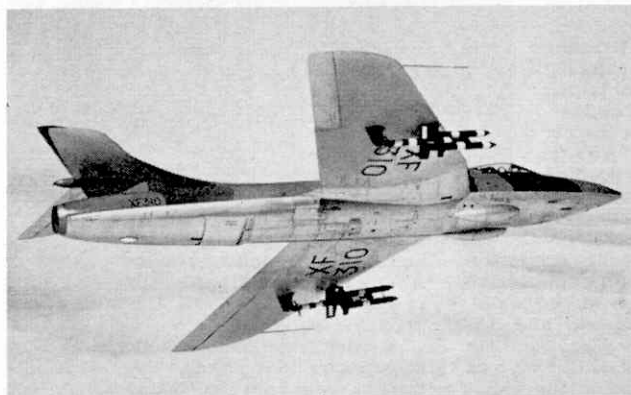

One of the first photographs of the Fairey Fireflash air-to-air guided weapon installed on the Hawker Hunter fighter.

world speed record of 1,132 m.p.h. But, on the whole, the engine-makers stole the show.

Bristol's were able to reveal that their Olympus B.O.16 is giving a thrust of 16,000 lb. without reheat, which is more than the announced power of any other turbojet, although de Havilland's Gyron is believed to be in the 20,000 lb. class. The scaled-down Gyron Junior, shown for the first time this year, is reported to pack up to 11,000 lb. of thrust into a package only 88 in. long and 32 in. in diameter—about the size of the Orpheus engine fitted in the Gnat light fighter.

The Gyron Junior will be coupled with a rocket engine in mixed power plant fighters under development in Britain, and we had a first glimpse of one of these rockets—the Napier Scorpion—in the air

for training crews in anti-aircraft missile techniques, test vehicles for Bristol and Napier ramjets and one of the Royal Aircraft Establishment's high altitude research rockets that will be fired to a height of around 100 miles from a launching tower at Woomera, Australia, next year.

It was good to learn from the Chief of the Air Staff, Air Chief Marshal Sir Dermot Boyle, that the R.A.F. does not expect missiles to replace manned aircraft completely in any role, because the aircraft industry relies on military orders to speed development and help finance its commercial designs. At present, except for long-range jet-liners, Britain leads the world in transport aircraft, and we saw them all at Farnborough, including the "stretched" Britannia 301 and Viscount 802, the Herald, and (Continued on page 596)



# Shipping Notes

## Giant Tankers

Here is a fine picture taken on the deck of the *Spyros Niarchos*, the giant tanker built by Vickers-Armstrongs Ltd., at Barrow, that was described and illustrated in the March issue of the *M.M.* A sister vessel, the *Eugenia Niarchos* is now being completed, also at Barrow, after being launched in August last.

One of the most interesting developments in the shipping world is the trend towards the construction of really giant tankers. The *Spyros Niarchos*, with her deadweight tonnage of 47,750, is still the largest single purpose oil tanker in the world in service, but she will soon lose this distinction to the *Universe Leader*, an 84,700-ton deadweight vessel built in Japan. This vessel will rank fifth in length among the merchant ships of the world, following the *Queen Elizabeth* and the *Queen Mary*, the *United States* and the *Liberte*. She has a width of 125 ft., and this makes her the vessel with the widest beam in the world. She is in fact too wide to pass through the Panama Canal and her draught when loaded is too great for the Suez Canal.

The *Universe Leader* was launched in August last. She was built in a dry dock, and her main engines, machinery and boilers were installed while the hull was being built. She was launched by flooding the dock, after which she was towed to an anchorage.

The *Universe Leader* was built in the former Japanese Imperial Navy Yard in Kure, but she was built for American interests, and will be used for carrying oil from the Middle East to the United States. The Kure yard has been leased by National Bulk Carriers Inc., an American company,

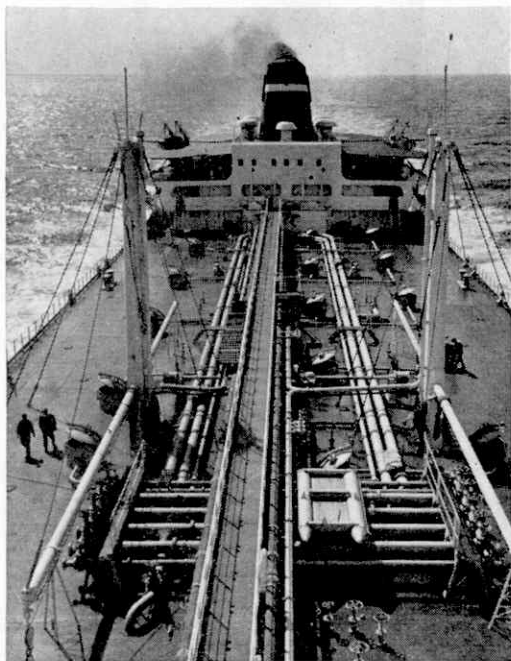

The illustration at the head of the page shows a striking deck view of the "Spyros Niarchos" at sea. This vessel, believed to be the largest single-purpose oil tanker in the world at the time of her completion, was built at Barrow by Vickers-Armstrongs Ltd., and described and illustrated in the "M.M." for March last. She is of 47,750 tons deadweight and during her trials she appreciably exceeded her designed speed of 17 knots, with complete absence of vibration or noise.

and the new tankers are the product of American technical knowledge and mass production methods and the skill of the Japanese workers.

A sister vessel will be launched at Kure in February 1957. Even these two mighty tankers will soon be surpassed by two 87,200-ton deadweight vessels to carry oil or ore. These also will be built at Kure, and their keels will be laid down during next year.

## New B.R. Cross-Channel Vessels

The upper illustration on the opposite page shows a vessel that will be of great interest to many readers of the *M.M.*, some of whom may actually sail in her or in one of her two sister ships. She is the *Duke of Lancaster*, a 5,075-ton cross-channel vessel built for British Railways. Her sister ships are the *Duke of Argyll* and the *Duke of Rothesay*, and all will be engaged in the overnight service between Heysham and Belfast. The *Duke of Lancaster* and the

*Duke of Argyll* were built by Harland and Wolff Ltd., Belfast, and the *Duke of Rothesay* by William Denny and Bros. Ltd., Dumbarton.

The three new vessels are among the largest of British Railways cross-channel ships. Their turbine driven twin screws give them a speed of 21 knots. Their length overall is about 375 ft., and they have a

The "Duke of Lancaster," one of three new vessels for the Heysham-Belfast service of the London Midland Region. British Railways Photograph.

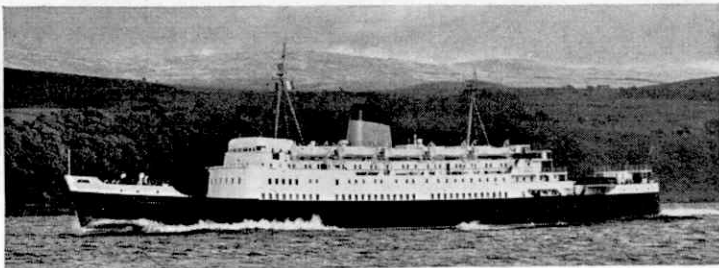

curved plated stem, a modified cruiser stern, tripod masts and a single low streamlined funnel specially designed to throw smoke clear of the passenger decks. They have both bow and stern rudders to make manœuvring easier.

Great care and thought have been devoted to ensuring the comfort of passengers, of whom 600 first class and about 1,200 second class can be carried. All the public rooms are comfortable and well decorated and lighted, temperature in them is controlled, and mechanical ventilation has been installed throughout. Sound reproduction equipment also is fitted, so that music or important messages can be broadcast in the public rooms, on decks and elsewhere. Another important feature is that Denny-Brown ship stabilizers are fitted, to ease rolling in bad weather.

### The *Reina del Mar*

From a British cross-channel service we turn to one between continents, connecting

Great Britain with the West Indies and the West Coast of South America. In this service the Pacific Steam Navigation Company of Liverpool has introduced the handsome new vessel shown in the lower illustration on this page. She is the *Reina del Mar*, a vessel with a gross tonnage of 20,225 built by Harland and Wolff Ltd. She has gracefully curved

superstructures that blend with the shape of the main hull and are designed on modern aerodynamic principles. Her single mast, well forward, is pleasingly raked, and a funnel of modern design throws smoke and steam well clear of the decks.

The length of the *Reina del Mar* is 600 ft. 7 in. and her breadth 78 ft. She has accommodation for 207 first class passengers, 216 cabin class and 343 tourist class, and this with her crew of 327 makes up a total complement of 1,093. The accommodation provided for passengers is of the very highest class, and all the usual amenities are available, including swimming pools for first and cabin class passengers.

The machinery of the *Reina del Mar* comprises two Parsons double reduction geared turbines, each driving a propeller shaft. They have a total power in service of 17,000 shaft horse power, with the propellers making 112 revolutions a minute. The turbines are fed with steam at a pressure of 525 lb. per square inch.

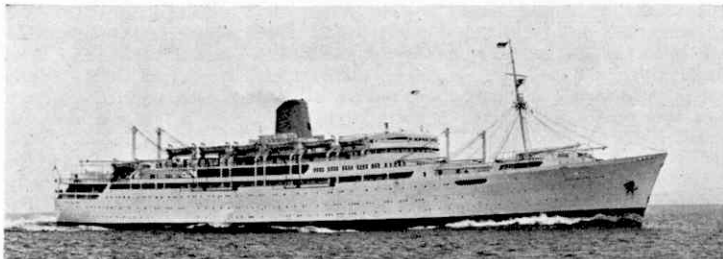

The twin-screw passenger liner "Reina del Mar," built by Harland and Wolff Ltd., Belfast. Photograph by courtesy of the Pacific Steam Navigation Company.

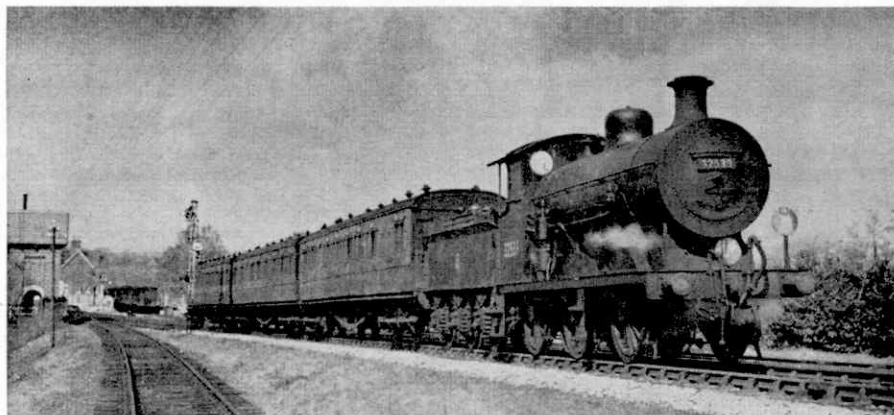

## A Joyous Occasion

### Reopening a Country Branch Line

By Garth Christian

THOSE who attended the first Test Match ever held at Lords, or the final broadcast from Savoy Hill, would have sympathised with our feelings. This was to be no ordinary event. Over a period of many months few living creatures had entered our village station, apart perhaps from foxes and a solitary badger. Willow herb and hedge parsley, groundsel and grass were growing between the sleepers, and each month the rails darkened under their coating of rust.

Then rumours started. Officialdom had slipped up. The Victorian railway company that built the line had promised a local landowner that four trains a day in each direction would run through his parish for evermore. Somehow the agreement had been overlooked. Our branch line would now have to re-open, and the sound of the locomotive whistle would again be heard on the Bluebell and Primrose line.

Soon a train equipped with a toxic weedkilling sprayer was seen on the line. So the rumours must be true! They were, and our line was to be reopened—until such time as an Act of Parliament closes it again.

To have mentioned this sad possibility would have seemed near to blasphemy on

the day we assembled for the reopening of the line. Even as passengers crowded into the first train, and the hour of departure approached, the carriage doors were polished and scrubbed by a couple of railway "officials"—not "cleaners," nowadays—quick to acknowledge the sense of occasion. Railway enthusiasts who had left London at 7.30 that morning, and schoolboy train-spotters from the coastal

towns clambered aboard, and soon we were joined by so many news reporters and photographers that it seemed as if the Press outnumbered the

public. A whistle blew, a flag fluttered as the Sun broke through, and the first train of the year to carry passengers along our line thundered out of the county town.

The effect on the local population was remarkable. Even as we clattered past the lovely mediæval Church amid the corn fields farmworkers leapt from their tractors to salute us; housewives greeted us from their cottage doors; and cattle fled for their lives.

Indeed, it was the behaviour of the cattle—and the birds—that most clearly distinguished this journey from any normal railway trip. A year is a long time in the life of a cow. Young stock that had never seen

**A train on the East Grinstead and Lewes line leaving Sheffield Park. The locomotive is a rebuilt ex-L.B.S.C. 0-6-0 of the class used for the local service restored in August. Photographs by S. C. Nash.**

a locomotive stampeded to distant corners of the meadows as our train rumbled into sight.

By contrast, sheep regarded us with the philosophical calm of the Transport Commission receiving a deputation of branch line supporters. Not so the birds. They fled in terror from the surrounding fields, unlike the birds holding territories beside the busy main lines.

It was only when I travelled through the August sunshine on this first passenger train of the year that I realised what a promising partridge season seemed to lie ahead. Here as elsewhere, partridges have been fast declining in recent years. Yet on this journey the partridge, after the rook, the wood pigeon and the chaffinch, was the species most frequently encountered.

Personal impressions can be sadly misleading, but it is perhaps worth recording that we counted two jays to every magpie, saw astonishingly few blackbirds—possibly the sequel to a local outbreak of disease last winter—and noticed no wild mammals. "Rabbits," said the man in the next seat, "are coming back again." We did not see one. Nor—more surprisingly—did any grey squirrels show themselves, though the

surrounding woods promised unusually vast crops of seed.

Like the heron that flapped slowly out of the path of the train before gazing at us from the safety of a meadow, I found it hard not to stare at my fellow passengers

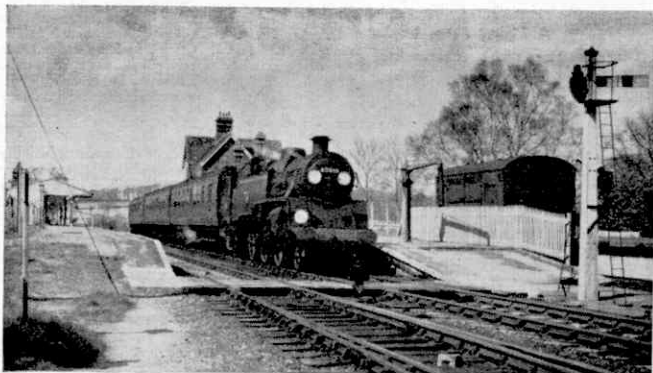

A through train Victoria-Brighton via East Grinstead at Sheffield Park in 1955. The locomotive is a B.R. 2-6-4T, the class represented by the Hornby-Dublo 2-6-4T.

who spent the journey leaning out of the windows. What persuaded the distinguished international horseman, the Hoveschoolboys and the Surrey stockbroker to join the host of eager natives living beside the line in making this quite unnecessary journey from our county town?

Was it that sense of occasion that prompted the railway officials to clean the white-washed compartments with extra special zeal? Was it the warm, friendly atmosphere as of a country club that is apt to mark trips of this kind?

The journey was not five minutes old before strangers began discussing "Can a nationalised undertaking sulk?" The question was prompted by our failure to stop at the first station on the line, though it lies in a village served by buses only once in two hours.

(Continued on page 596)

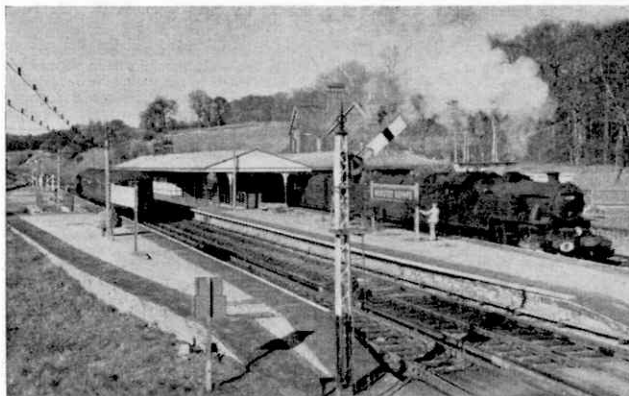

An Oxted-Brighton train leaving Horsted Keynes, with an electric train to Seafood, via Haywards Heath, on the left. Horsted Keynes remained open for the local electric train service to and from the Brighton main line.

# Air News

By John W. R. Taylor

## A Flying Farm Implement

One of the most interesting aircraft at the international agricultural aviation exhibition in New Zealand this month will be the new E.P.9 "flying jeep", shown in the accompanying illustration. Intended to carry a pilot and five passengers or a ton of freight, it was built at Stapleford Aerodrome, Essex, by Mr. Edgar Percival, who broke many pre-war flying records with aircraft of his own design and has done all the test flying of the E.P.9 himself.

It was designed primarily for farm work in New Zealand, where aircraft are used to spread some half a million tons of fertiliser each year over hilly ground to improve the quality of the grass, as well as for crop-spraying and seed-sowing. Their work has enabled New Zealand farmers to keep an extra four million sheep and one million cattle, and so earn £6 million more each year.

Most of the aerial farm-work has been done with converted Tiger Moth biplanes; and the E.P.9 now offers greatly improved efficiency. Its roomy two-seat cockpit is high-set to give a good forward view for low-flying among the hills and, even when a hopper for a ton of chemicals is installed in the cabin, it can carry three mechanics and loaders, so that it can fly from farm to farm as a self-contained unit. Alternatively, the cabin is large enough to carry sheep, bales of wool or 44-gall. petrol drums, which are loaded through sideways-opening doors that form the rear end when closed. As an air ambulance it can accommodate two stretchers and two seated passengers.

Top speed of the E.P.9 with a 270 h.p. Lycoming engine is 144 m.p.h., and it will take off in only 115 yds. in a 5 m.p.h. wind. It has a span of 43 ft. 6 in., is 29 ft. 6 in. long and weighs 3,980 lb. with a full load of chemicals.

## Supersonic X-7 Saves Dollars

Instead of testing their latest ramjet engines in normal rocket-type missiles, the U.S.A.F. are using a pilotless aircraft that can be recovered intact after every flight. Designated the X-7, it has been designed by the Lockheed Missile Systems Division and looks like a small straight-wing fighter. The ramjet engine to be tested is mounted under its rear fuselage.

After being launched at height from a B-29 Superfortress, the X-7 flashes through the stratosphere under ramjet power at well beyond the speed of sound, until its fuel is exhausted. A parachute is then opened automatically to lower it gently to the ground. This saves a great deal of money compared with the use of non-recoverable rockets.

## Six Years of Flying Scholarships

Since the Air Ministry began the flying scholarship scheme for members of the Air Training Corps and the R.A.F. sections of the Combined Cadet Force six years ago, 2,139 cadets have been given the chance to train as pilots of light aircraft. Of these, 1,614 had qualified for their Private Pilot's Licence by the middle of this

year, when more than 100 others were under instruction.

Any cadet over the age of 16½ yrs. may apply for a scholarship, which is worth about £150. If successful, he is sent to a flying club in his home district, where he is expected to complete the course of 30 hrs. flying within three months, if possible.

## Helicopter Lands in Volcano

A helicopter has made three landings in the crater of Ngauruhoe, an active volcano in the centre of New Zealand's North Island. Purpose of the hazardous operation was to enable scientists of the Department of Scientific and Industrial Research to set up a recording post in the crater to "feel the volcano's pulse." In this way, it is hoped to obtain advance warning of threatened eruptions.

## New Version of the P.1

Latest news of the English Electric P.1 supersonic jet fighter is that the pre-production batch of 20 now being built will each have two Avon turbojets with reheat. They will be designated P.1B to distinguish them from the Sapphire-engined prototypes, which are now known as P.1A's.



Edgar Percival E.P.9, designed primarily for farm work in New Zealand.

Three P.1A's were built. Two are being used for intensive flight trials, including gun-firing at supersonic speeds; the other was tested to destruction in a ground test rig. The 20 pre-production P.1B's will each be assigned a particular job, such as testing radar, auto-pilots or armament, to speed the development of the fighter for service with the Royal Air Force.

## Folding Stairs for Viscount

The Viscount has again made history by becoming the first British air liner available with built-in folding stairs, making it independent of expensive ground equipment. This may seem a minor detail, but the Americans in particular look for this kind of refinement in their air liners, and all the Viscounts for Capital Airlines from the 29th machine onward will have hydraulically-operated "air steps".

The steps weigh 174 lb. and need a further 116 lb. of operating equipment. They take only 30 sec. to extend or retract, and ensure speedy turnrounds by enabling passengers to embark and disembark quickly.



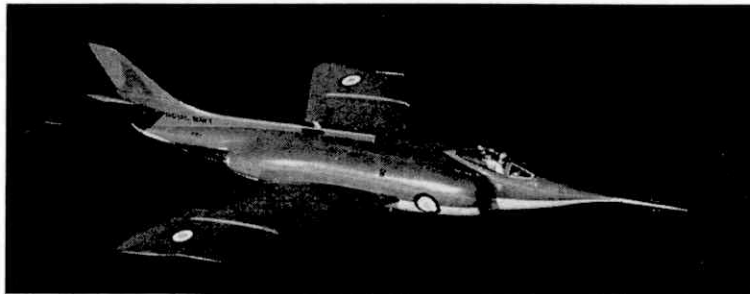

The Vickers-Supermarine N.113 twin-jet Naval fighter, on order for the Royal Navy, took part in this year's S. B. A. C. Display at Farnborough described on page 557.

### Decca Solves Airport Problem

Nothing is more annoying than to fly quickly from one country to another and then to waste time circling while other air liners land and take off. All over the world, airports are searching for ways of getting aircraft in and out more quickly without increasing the danger of collision at night or in bad weather.

Obviously, the more accurately the positions of air liners are known, the closer they can be allowed to fly to each other, and the Ministry of Transport and Civil Aviation have announced that aircraft fitted with the Decca Navigator system will not in future need to be separated so much as other machines in the approaches to London Airport.

This is a great tribute to the accuracy of Decca, with which a pilot can check the position of his aircraft at any moment by looking at a small roller map on which his path is drawn by a moving pen. The system is worked by signals from radar stations on the ground and is used by B.E.A. throughout western Europe. A long-range development known as Dectra is now being tested to improve the accuracy of navigation over the Atlantic.

### 200 m.p.h. American Helicopter

During its military trials, one of the two McDonnell XV-1 convertiplane prototypes has achieved an unofficial helicopter speed record of 200 m.p.h. This is about 40 m.p.h. better than the top speed of any other rotating wing aircraft, and justifies the claims made for convertiplanes.

The XV-1 takes off as a helicopter, with its 550 h.p. Continental engine driving a compressor to supply air through the hollow rotor blades to pressure-jet units at the tips. During cruising flight the engine drives a normal pusher propeller behind the cabin, leaving the rotor to "free-wheel" in the airflow like the unpowered rotor of an autogyro, its lift supplemented by small fixed wings.

### Bags of Petrol

A new method of transporting bulk supplies of petrol by air in synthetic rubber bags is helping development of the remote central Highlands of New Guinea, by keeping fuel prices to a minimum.

Previously, petrol, kerosene

The McDonnell XV-1 Convertiplane takes off as a helicopter, but in cruising flight its engine drives the normal pusher propeller, seen behind the cabin.

and other fuels had to be flown from the underground storage tanks at Lae in heavy 44-gall. drums, which were awkward to stack in the cabins of the Dakotas of Mandated Airlines and had to be flown back empty. Now, the fuel is simply pumped into four of the 200-gall. rubber bags, which are secured to the floor of the aircraft and, when filled, occupy all the available cargo space.

On arrival at Goroka aerodrome, which is 120 miles from Lae and 5,000 ft. above sea level, the fuel is emptied into the local storage tanks, after which the bags can be folded and stowed in the aircraft, leaving most of the cabin free for local produce to be flown out to market in Lae.

### Houses Carried by Air

Another item of news from New Guinea tells of the latest unusual job done by the small single-engine de Havilland Beavers which Qantas Empire Airways operate there. This task was the transport of two prefabricated houses from Bulolo to Menyamyama, which is inaccessible by road. They completed the job in 10 days, making a total of 51 round trips over the 40-mile route. As there was no aviation fuel at Bulolo, the Beavers first had to fly in a supply of petrol.

### North Country Dragon

The network of air services from Newcastle-on-Tyne to London, Belfast, Bergen, Liverpool, Paris, Amsterdam and Dusseldorf, previously operated by Hunting-Clan Air Transport is now being flown by Dragon Airways. This company was taken over in November 1955 by Hunting-Clan and two steamship companies, Elder Dempster Lines and the Tyne Tees Shipping Company. Its original fleet consisted of three Herons and one Viking.





L.M.R. 0-8-0 No. 48952, a former L.N.W.R. "Super D," is here approaching Watford Tunnel on its way to Willesden. Photograph by S. Creer.

## Railway Notes

By R. A. H. Weight

### Around with Stopwatch and Notebook

Some of my own recent journeys deserve brief comment first this month.

The 11.10 a.m. from Paddington is one of the best expresses on the Birmingham-Wolverhampton-Chester-Birkenhead route. I found it well filled, consisting of eight coaches weighing about 295 tons all found, headed by *Restormel Castle*, stationed and manned at Wolverhampton (Stafford Road). This was a 2-hr. train to Birmingham, though 12 min. extra have been allowed for the time being on account of the slow running necessary through Banbury, where the station, track and marshalling yard rebuilding and improvement works are well in hand. Another reason is that it is necessary to crawl over a temporary single line carrying all trains across the high Souldern Viaduct, between Ardley and Aynho Junction, just over 60 miles from London, where heavy repair work lasting perhaps for a year has been necessitated owing to serious subsidence of some of the piers.

Much earlier on the run we had the slow passage of a long section where track relaying was in progress. But with speeds up to 78 m.p.h. when possible, we were only 2½ min. down on the amended timing when reaching the first stop at Leamington Spa; we were almost punctual at Birmingham and precisely so at Wolverhampton.

Engines were changed at Wolverhampton as usual on those trains, although the preceding *Cambrian Coast Express* is worked through to Shrewsbury by a Castle locomotive and men stationed at Old Oak Common; the return 153-mile run is made the same afternoon on the corresponding southbound service to Paddington. Occasionally King class 4-6-0s go through to Shrewsbury or beyond.

The busy L.M.R. main line between Crewe-Stafford-Rugby-Euston is easily graded for the most part.

The loads of expresses are often heavy and a number of the timings fast. Sometimes on that account when a suitably powerful locomotive is not available, double-heading is resorted to. I rode the Blackpool and Furness line to London express, due Euston at 3.5 p.m., with a 15-coach load headed by a "Black 5" mixed traffic 4-6-0 assisted in front by a class 2 4-4-0. The latter elderly engine, however, more accustomed to carriage shunting at Crewe than to tackling a 133-mile non-stop run at nearly 59 m.p.h. average from Stafford to London, was not equal to the task, so we arrived late after a trying experience for drivers and firemen.

Steam express runs from a London terminus to Brighton are unusual, as this 51-mile main line has been electrified for more than 20 years, together with various associated S.R. routes. One of the fastest such for a long time, probably, was made by the rebuilt N15x

4-6-0, *Stephenson*, with a 7-coach special train last June. This was originally one of the 4-6-4 express tank locomotives constructed to haul the heaviest Brighton line fast trains prior to electrification, and has since been withdrawn for scrapping. Its farewell performance on the old home ground was stirring indeed! From Coudsdon, where there was a short signal stop, we were closely behind an express electric train and running quite as fast with speeds up to 75 m.p.h. downhill and 65 on gradually rising grades. Brighton was reached in the hour from London Bridge as booked, including fully 5 min. lost by delays.

Northbound from Brighton in a very light train, forming the through portion from Sussex coast resorts to Oxford and Chester, on the regular weekday service, U1 3-cylinder 2-6-0 No. 31905 gained over 5 min. on the 30-mile run to Redhill. After attaching Kent portions bound for Birkenhead, brought in rather unusually by an N class Mogul instead of an express engine, we had a 12-coach 400-ton formation. B.R. 2-6-0, 76060, hauled this with great gusto over the ups-and-downs of the Surrey hill country to Guildford and reading, where a W.R. Castle locomotive took over.

### Locomotives in the News

Continuing the chronicle of new engines and their allocation it must be announced that Nos. 76063-9 of the 2-6-0, class 4 type, building at Doncaster, are to be stationed at Eastleigh, 71A, as ready. Several have been reported making preliminary runs on the G.N. & G.C. sections, E.R., as well as in their appointed Southern area.

Another class 4 2-6-4T to 34E, Neasden is No. 80142, with the next one ready at Brighton at the time of writing, for the same shed.

New class 9 2-10-0s include No. 92087 to 36A, Doncaster, built at Swindon; No. 92099, 54B, Tyne Dock; and No. 92100, 18A, Toton. The last two are from Crewe Works.

Class 5 4-6-0s numbered 73127-9 have entered W.R. service, the first named being allocated to 84G, Shrewsbury; it was constructed at Derby.

From Darlington Works class 2 2-6-0s, 78055-6, went to 6D, Chester (Northgate).

W.R. received 0-6-0Ts, 3407-8, built by the Yorkshire Engine Company, and diesel-electric shunters from Derby, numbered 13263-7.

Diesel-mechanical 0-6-0 shunter, 11143, was added to stock at 32B, Ipswich.

It is pleasing to report that a good many more locomotives are painted green, including the Schools 4-4-0s *Westminster* and *Merchant Taylors*, W.R. Halls, Counties, Manors and Granges and main line diesel-electric engines Nos. 10001, 10201, etc. The last named S.R. type has been regularly in passenger service from Derby to St. Pancras and back during the summer.

During the summer season, with its many additional

between St. Pancras-Leicester-Derby, or St. Pancras-Kettering-Nottingham, and presuming that the Jubilee 4-6-0s will continue to be the largest locomotives usually employed, the accelerations to round about a mile-a-minute average applied to several of the principal up and down expresses along those routes from 17th September are particularly commendable. I shall hope to report by experiences after travelling by one or two.

#### Eastern Region Notes

When I left Wood Green, after many years' residence overlooking the East Coast main line, just over five miles from King's Cross, the outer suburban or Cambridge line semi-fast trains such as the one seen in the upper photograph on this page were often hauled by 4-4-0 or 4-4-2 tender engines. The largest and most powerful tanks were of the N2 0-6-2 suburban type.

Now there are many L1 2-6-4s, capable of considerable speed in spite of their small diameter driving wheels, and used also for hauling heavy main line empty trains between King's Cross and carriage sidings near Hornsey or Wood Green. The indicators fixed to the post, close-up on the right, work automatically from the signal box and inform would-be crossers of the three centre lines whether a train is accepted or actually approaching on each. This warning provision is found at some other points down the ex-G.N.R.

More diesel railcar services have been introduced in East Anglia, with frequent journeys on the Norwich to Lowestoft or Yarmouth routes, as well as in Lincolnshire.

At the end of this year, with the introduction of electric services between Shenfield and Southend, the Eastern Region electric train services will be completely revised. There will be new through trains between Liverpool Street and Southend.

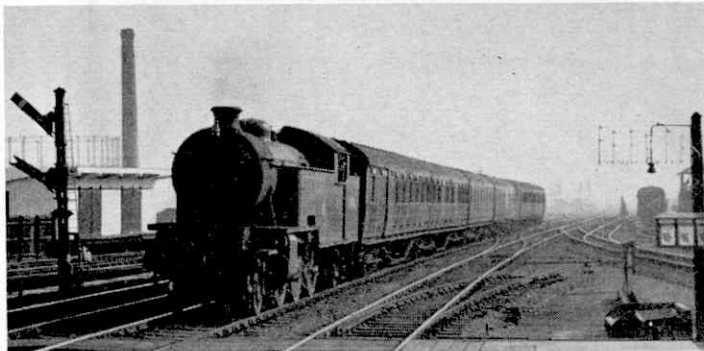

E.R. 2-6-4 Tank No. 67746 on a King's Cross-Royston train is approaching Wood Green, the site of many years of locomotive and train observations by the Author. Photograph by D. Ives.

holiday and excursion trains, there have again been numerous instances of locomotives being noted far from their home stations, or running long distances over another Region's territory. For example, there were B1 4-6-0s in North Wales, at Morecambe, Gloucester and Ayr, L.M.R. 4-6-0s at various N.E.R. stations as well as in Sussex and Kent, a Clan 4-6-2 on the severe and scenic West Highland line and express engines stationed in Scotland on intermediate fast trains running in England towards Euston, St. Pancras or King's Cross, and so on.

#### Highlights of the Winter Time Tables

An outstanding feature of the B.R. express services now operating is the *Talisman* express leaving Waverley station, Edinburgh, and King's Cross, London, on Mondays to Fridays at 4 p.m. A 6 hr. 40 min. run between the two capitals is made with one stop at Newcastle, so that the speed is similar overall to that of the record-making 6½-hr. summer *Elizabethan*.

Between London and Newcastle the average speed is over 60 m.p.h., so that the *Talisman* is the fastest British train running, say, 200 miles or more without stop, and is the present quickest Anglo-Scottish flyer. The 8-coach maroon painted trains, which pass each other north of York, are composed of luxurious new or reconditioned corridor and restaurant cars. Engines are changed at Newcastle, King's Cross, Gateshead and Haymarket sheds share in the working, and during the first week A4 streamlined Pacifics were doing well on it.

In view of the rather steeply graded sections of the Midland main lines

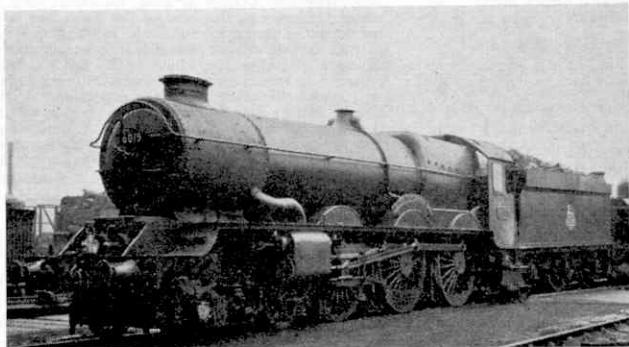

A King 4-6-0 with a double chimney. No. 6015, "King Richard III," was photographed at Old Oak Common by G. Clarke.



## Olympic Games City

### How Melbourne Grew to Greatness

By W. H. Owens

ON Thursday, the 22nd November, H.R.H. The Duke of Edinburgh will open the sixteenth modern Olympic Games at Melbourne, Australia, where they will continue into December. This will be the first time that the Games have been held in the Southern Hemisphere, although they were revived in Athens exactly sixty years ago.

Melbourne has been actively preparing for two years or more to welcome the sportsmen of the world on this occasion. A special prefabricated Olympic Village has been built on the outskirts of the city, and in this thousands of visiting athletes and Games officials will be housed. The main stadium will be the famous Melbourne Cricket Ground, and there a new triple-deck grandstand has increased the accommodation for spectators from 80,000 to well over 100,000. A new

Olympic Park, with three sports fields and a swimming stadium, is the venue for the swimming and diving, water polo, cycling and other competitions.

This year the symbolic Olympic torch will make its longest journey, half across the world. The flame is kindled on

Mount Olympus in Greece, just above the scene of the ancient Games, and after being carried to Athens in relay by Greek athletes it will leave by air for Darwin, in Australia's Northern Territory. Before the long flight the flame will be placed in a miner's lamp, and it

will be carried in a fireproof steel box lined with asbestos. A fire guard will sit beside the box throughout the journey, with a hand extinguisher ready for emergency use.

From Darwin an R.A.A.F. Canberra jet bomber will fly the flame on to Cairns, on the east coast of Australia, from where

The Melbourne Cricket Ground, an aerial view of which is shown at the head of the page, has been the scene of many international sporting contests as well as Test cricket struggles. To accommodate Olympic spectators, the stand at the left has been enlarged to increase the total capacity from 80,000 to 110,000. Opening and final ceremonies of the Games will be held in this stadium, which will be the scene of the series of athletic competitions. The Richmond Football Ground in the background, will be the assembly point for athletes for the opening and closing ceremonies. Australian official photograph.

Melbourne's main thoroughfare is Collins Street, seen in this Qantas photograph.

it will be taken by 2,750 relay runners down the long coastline, through Brisbane and Sydney, to the Olympic Stadium at Melbourne. There the final runner will hold the torch aloft in salute to the spectators and will deliver it to Olympic officials as the Games begin.

The city of Melbourne is one of the most beautiful in the Commonwealth and has an interesting history. In little more than a century, the place has grown from an obscure settlement on a river creek to a state capital and seaport of one and a half million people. Today it is Australia's second largest city, with tall modern buildings, wide streets and spacious parks and gardens.

In 1835, forty-seven years after the first settlers reached Australia from Britain, John Batman, a farmer in the island state of Tasmania, formed a company to colonise Port Phillip Bay across the Bass Strait. He and his companions defied authority by settling on the banks of the Yarra River

and obtaining land by treaty with the aborigines.

Batman was in fact the first white man in Australia to give something in return for land. Meeting the tribal chiefs, he gave them such prized articles as blankets, knives and mirrors in exchange for 600,000 acres of land about the river estuary. Eight of the chiefs actually put their marks to a document that Batman had drawn up, and on which he had sketched a map indicating the limits of his newly acquired territory.

Although the Governor, Sir Richard Bourke, repudiated the deal, Batman's settlement was an established fact before any effective action could be taken, and the hamlet he had founded was growing fast. Only a year later, in 1836, it was recorded that a town called Bearbrass—Melbourne's original title—was in being on the Yarra River, populated by "142 males and 35 females, 26,000 sheep, 57 horses and 100 cattle." The following year Governor Bourke paid the settlement a friendly visit and renamed it after the Prime Minister of England at that time, the second Viscount Melbourne. He himself is commemorated in the name of Bourke Street.

The most eventful period



One of Melbourne's most prized historical assets is Captain Cook's cottage, brought from Great Ayton, Yorkshire, the explorer's birthplace, and rebuilt here in Fitzroy Gardens. Australian official photograph.



in Melbourne's history followed the discovery of gold in the state of Victoria in 1851. As the cry of "gold" rang round

and for a time lawlessness ran riot. Amid the new-found wealth there were also scenes of indescribable squalor and misery.

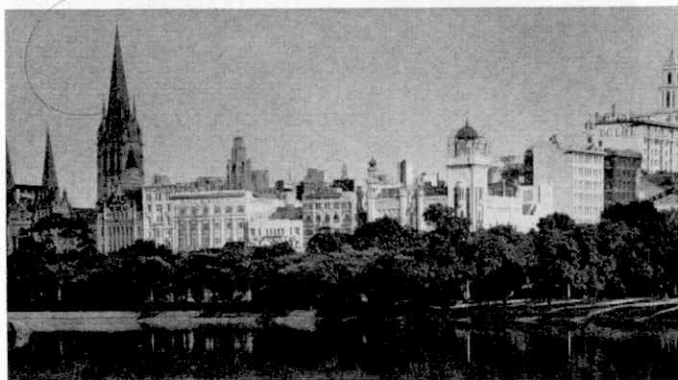

Melbourne skyline, from the south bank of the River Yarra, with the spires of St. Paul's Cathedral on the left. Australian official photograph.

the world that year, the young colony reached maturity almost overnight. Fortune hunters from America, China, Peru, the British Isles and every country in Europe flocked to Ballarat, sixty miles from Melbourne, where the richest strikes were made.

At first the rush to the goldfields brought the city to near standstill. It is said that for a time Melbourne was inhabited almost entirely by women and children, its shops, offices and schools closed. The city's Port Phillip became a forest of masts of ships deserted by their crews. At the end of the year, more than £1 million worth of gold had been discovered.

By 1853 it was estimated there were more than 100,000 diggers at work on the Victoria goldfields, and Melbourne became the most overcrowded city in the world. During the first three years of the gold-rush its population increased three-fold; in the next three years it doubled again. Speculators in land and property made enormous fortunes,

Yet, in spite of these things, the gold boom brought lasting good to the state of Victoria, as it did indeed to Australia as a whole. Melbourne enjoyed a lion's share of the new prosperity. The city thrived not only on gold, but on wool sent down from the fast expanding farms up country for export. From Melbourne Harbour the fast and graceful clipper ships, born

of the gold-rush days, carried Australian wool across the world. Today the seaport is the seventh largest in the Commonwealth and handles a seaborne trade worth hundreds of millions of pounds a year.

Melbourne owes a great deal to her 19th-century planners, who designed the city on the most spacious lines. The skyline of buildings, towers and spires above the Yarra River makes an unforgettable sight.



An aerial view of Melbourne. Qantas photograph.

# MECCANO MAGAZINE

## Junior Section

**S**HOPPING is a very serious matter at any time, but it becomes doubly important when Dinky Toys and Supertoys are concerned. This is quite clear from the concentration that was being shown by Alan McCaffery of Grange-Over-Sands, when the accompanying photograph was taken.

Alan is eight years old. He saves his pocket money to buy new Dinky Toys, but is always facing a great problem—whether to buy a Dinky Toy he wishes to have as soon as he has enough saved up for it, or whether to go on a little longer and buy a Supertoy for which his longing is equally intense.

Tidiness is the hallmark of the Meccano enthusiast, and it is also a



Studying his shopping list. But Alan McCaffery is interested in Dinky Toys and he is making a selection from his Dinky Toys booklet.



characteristic of Meccano Clubs. Litter is something that is absolutely forbidden in the latter, the members having discovered that full time for actual model-building, the joy of their lives, is only reached when everything they want is at hand, and can quickly be picked up for use.

With this in mind Mr. Z. A. de Beer, Leader of the Cape Peninsula Meccano Club, planned and made the handsome storage cabinet seen in the lower picture on this page. One of the Club's most devoted followers is Mr. de Beer's daughter, who promptly placed herself in the picture, saying quite plainly that the photograph would not be worth while taking unless she were included in it! This is the right spirit, developed by her keen interest in the Club and in all its doings.

Here is a fine cabinet for storing Meccano parts that has been planned and made by Mr. Z. A. de Beer for the Cape Peninsula M.C., of which he is Leader. Also in the picture is his daughter, who insisted that the photograph would be incomplete without her.

# Easy Model-Building

## Spanner's Special Section for Juniors

### A Jeep and a Useful Brake Mechanism

SOME time ago I received details from Dr. D. Rice, Chichester, of an attractive model Jeep built by his son Graham, who is only seven years old. The model was very realistic and was a very fine effort for so young a boy. It did not appear to be constructed with any particular Outfit, but the general effect was such that I felt sure a similar model would appeal to other young Meccano enthusiasts. 1

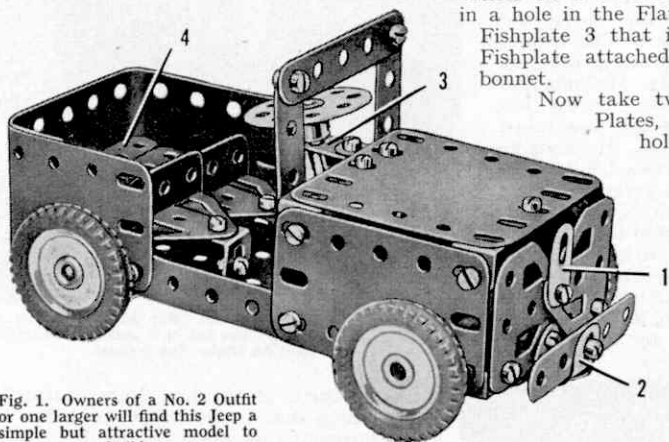

Fig. 1. Owners of a No. 2 Outfit or one larger will find this Jeep a simple but attractive model to build.

therefore rebuilt the Jeep so that it could be made with parts in a No. 2 Outfit, while keeping as closely as possible to Graham Rice's own effort, and the result is seen in the delightful model shown in the accompanying pictures.

The main frame or chassis of the Jeep is a  $5\frac{1}{2}'' \times 2\frac{1}{2}''$  Flanged Plate, and to this you should bolt a  $2\frac{1}{2}'' \times 1\frac{1}{2}''$  Flexible Plate on each side to represent the sides of the bonnet. The upper corners of these Plates are then connected by two  $2\frac{1}{2}'' \times \frac{1}{2}''$  Double Angle Strips. You can make the radiator from two Flat Trunnions bolted together by their pointed ends, with a Fishplate 1 fixed by the same bolt. Now bolt a  $2\frac{1}{2}'' \times 2\frac{1}{2}''$  Flexible Plate to the two Double Angle Strips to complete the top of the bonnet. The front bumper is a  $2\frac{1}{2}''$  Strip. Bolt an

Angle Bracket 2 to the centre of this Strip then fix it to another Angle Bracket attached to the front of the Flanged Plate.

You can make the windscreen from three  $2\frac{1}{2}''$  Strips. Fix two of these to Angle Brackets bolted to the rear corners of the  $2\frac{1}{2}'' \times 1\frac{1}{2}''$  Flexible Plates, then attach the third Strip between the upper ends of the Strips already bolted in place. For the steering wheel you should use a Bush Wheel on a 2" Rod. Support this Rod in a hole in the Flanged Plate, and in a Fishplate 3 that is fixed to a second Fishplate attached to the top of the bonnet.

Now take two  $5\frac{1}{2}'' \times 1\frac{1}{2}''$  Flexible Plates, overlap them nine holes and bend them as shown to make the back and sides of the body. Bolt the Plates to the Flanged Plate in such a way that three clear holes are left between the sides of the body and the sides of the bonnet. You can now pass the  $3\frac{1}{2}''$  Rods that form the axles through

the flanges of the Flanged Plate, and fix on them 1" Pulleys fitted with Motor Tyres. Space each Pulley from the Plate by a Washer.

The front seats are two Trunnions. Bolt one of these to a  $\frac{1}{2}''$  Reversed Angle Bracket fixed to the Flanged Plate, and attach the other to a made-up reversed angle bracket formed by two Angle Brackets bolted together. The rear seat 4 can be made by connecting two  $2\frac{1}{2}''$  Strips with a Fishplate. Fix the seat to an Angle Bracket bolted to the back of the body.

The gear lever 5 is a Rod and Strip Connector, which you should bolt to an Angle Bracket fixed to the Flanged Plate.

Parts required to build the Jeep: 6 of No. 5; 4 of No. 10; 8 of No. 12; 2 of No. 16; 1 of No. 17; 4 of No. 22; 1 of No. 24; 1 of No. 35; 36 of No. 37a; 36 of No. 37b; 4 of No. 38; 2 of No. 48a; 1 of No. 52; 1 of

No. 125; 2 of No. 126; 2 of No. 126a; 4 of No. 142c; 2 of No. 188; 2 of No. 189; 1 of No. 190; 1 of No. 212.

### A Screw Operated Brake

In Meccano model-building, just as in real life, it is essential to have precise control of our models and mechanisms, so that we can start and stop them as necessary. Starting the models is usually quite easy; all we have to do is to turn a handle or move the lever that controls a Clockwork or an Electric Motor. To stop them brakes are necessary, and designs for simple but powerful brakes for Meccano models turn up time and again in my correspondence.

Possibly the simplest but certainly one of the most effective brakes used in Meccano model-building consists of nothing more complicated than a length of Cord passed round a Pulley fixed on the shaft we want to slow down or stop. The ends of the Cord can be tied to a lever, and whenever we pull this lever the Cord is tightened round the Pulley.

This type of brake is very effective, but it has one disadvantage—the brake is applied only while the pressure on the lever is maintained. As soon as we release our hold on the lever the brake is taken off and the shaft is free to turn.

Clearly this will not do for models such as cranes, in which we may want to raise a load and hold it up while the crane is swivelled or is moved into a new position. What we need in this case is a brake control that will remain "on" while we attend to something else, and fortunately this is quite easy to

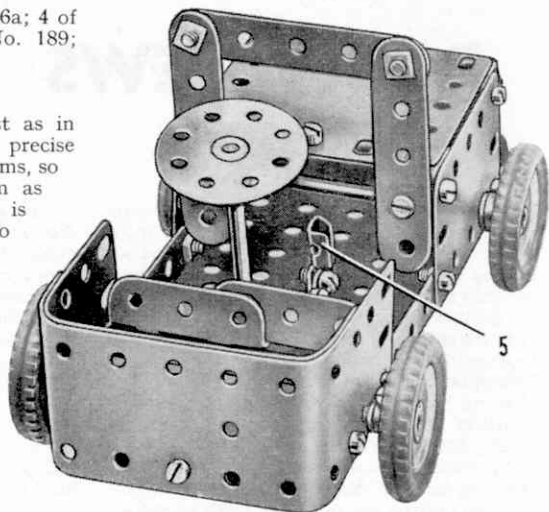

Fig. 2. This rear view of the Jeep shows how two overlapped Flexible Plates are used to form the sides and the back of the model.

arrange if you have a Screwed Rod in your Meccano collection.

Fig. 3 shows a simple strap and screw brake that can be used in models of many kinds. The Pulley 5 is fixed on the shaft 6 and a length of Cord 4 is passed round it. One end of the Cord is fastened to a bolt 7 and the other end is tied to a Threaded Boss 2 screwed on to a Screwed Rod 3. The Screwed Rod is held by Collars in a  $2\frac{1}{2} \times \frac{1}{2}$  Double Angle Strip, and it is fitted with a Bush Wheel 1 that forms a control wheel. When this wheel is turned the Threaded Boss is screwed along the Screwed Rod, and thus tightens or slackens the Cord round the Pulley 5, depending on which way the Wheel is turned.

In the picture a 2" Pulley is shown, but this can be replaced by either larger or smaller Pulleys if necessary. You should remember however, that the larger the diameter of the Pulley the greater will be the braking effect obtained.

The next time you build a crane try equipping it with a brake of this kind. You will find that you will

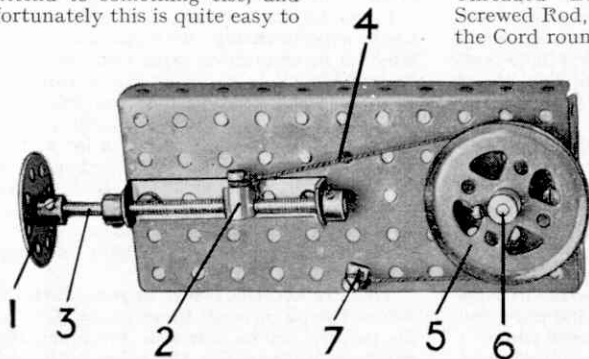

Fig. 3. A powerful screw operated brake mechanism suitable for models of many kinds.

get a great deal more fun from the model.

# DINKY NEWS

By **THE TOYMAN**

## Bristol 173 Helicopter

WHEN events in real life bring particular vehicles, aeroplanes or machines into the news, there is a considerable demand among Dinky Toys enthusiasts for models of these items. So it is understandable that for quite a long time now a large number of the suggestions for new models I have received have called for a Dinky Toys helicopter. This month I am glad to be able to give you details of the latest addition to the range, a splendid model of the Bristol 173 Helicopter.

In recent years widespread attention has been focused on helicopters as a result of their increasing use in rescue work of many kinds. During military operations, it is often necessary to transport wounded personnel for hospital attention from

areas in which it is impossible to land ordinary aeroplanes, and the ability of helicopters to land and take off almost vertically has proved invaluable in such cases. Air-sea rescue is another field in which the helicopter comes into its own; and most readers will have read accounts in newspapers of how helicopters have been used to bring relief to the inhabitants of isolated villages when normal communications have been cut by snowstorms or disastrous floods. Generally the helicopters used for rescue work are comparatively small machines, capable of carrying three or four passengers.

In addition to these important rescue services, helicopters can be used effectively to speed up passenger transport between towns and outlying airports, or as air-buses between important centres of industry and commerce. For use on passenger routes a larger type of helicopter is required, and our Dinky Toys model is based on one of these machines.

The Bristol 173 Helicopter, Dinky Toys No. 715, is modelled on a 14-seater, twin-engined machine, with two 3-blade rotors arranged in tandem. As you can see from the picture of the model, the Bristol 173 is a striking aircraft, with one of the rotors mounted just behind the pilot's cabin and the other arranged slightly higher at the top of the large tail fin. The fuselage of the Dinky Toys model is enamelled light blue and the rotors are painted red. The model is fully detailed, and the markings

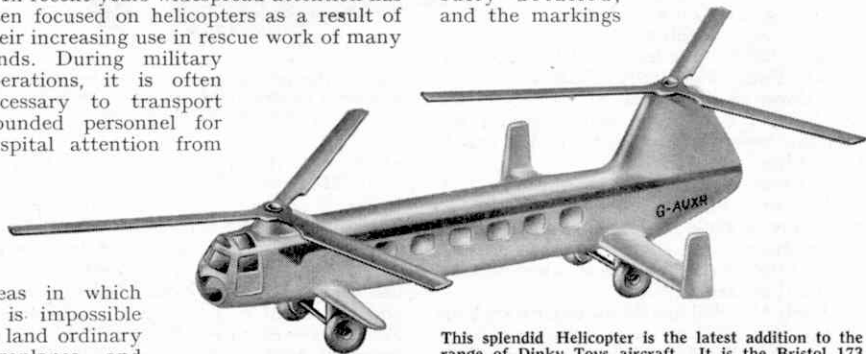

This splendid Helicopter is the latest addition to the range of Dinky Toys aircraft. It is the Bristol 173 Helicopter, Dinky Toys No. 715.

include a red flash along each side of the fuselage, just above the main cabin windows.

I wonder how many enthusiasts have tried experimenting with public works schemes in connection with their layouts? In real life roads under repair or trenches dug for the purpose of laying pipes or cables are common features in our towns, and I can assure you there is a lot of fun to be had reproducing these schemes in miniature. I have arranged road repair schemes on previous occasions, and this time for a change I decided to try a scene representing cable-laying along a busy street.

You can see the result of my efforts in two of the pictures on these pages. One of the pictures shows a trench dug along the street ready to receive the cable, while the workmen are busy unloading the cable drums from a lorry. In the other picture





Handle with care! Cable drums being unloaded ready for use in a busy cable laying scene.

the actual cable-laying has been completed, the trench is being filled in and a Diesel Roller is busy smoothing out the new road surface.

Scenes of this kind are fun to arrange and they provide plenty of opportunities for really interesting play schemes. The actual trench is easy to make, and no digging is necessary! All you have to do is to arrange the roadway on blocks, leaving a narrow channel between the blocks to represent the trench. For the drums I was

able to make use of the Cable Drums included in the range of Hornby Gauge 0 Train Accessories. These drums are attractively finished and provide a convincing touch of realism to the scene.

By the way, don't forget that when work is in progress some kind of traffic control is required. Unless the street is very wide, single lane traffic working will be needed, as shown in the illustration above, with a control point at each end of the excavations to direct the flow of traffic.



In this view the cable has been laid and an Aveling Barford Diesel Roller is at work on a new road surface over the excavations.

# Loading Up the Wagons

By "Tommy Dodd"

**I**N one or two of our recent talks we have spoken about the running of passenger trains, which gives fine variety in the make up of trains and in ways of working traffic. But there is just as much fun, and perhaps even more variety, in the working of goods trains, for there is splendid scope for devising miniature loads, for arranging road services in conjunction with the railway, and for many other schemes of real interest.

Road services alone will give endless pleasure. Every boy I know has at least some Dinky Toys and many of you have really large collections. In most of these fleets there are bound to be lorries to fit in with any railway scheme.

Loads in your goods wagons can be of the simplest kind, at first at any rate. Most of us begin with many of the little oddments that can be picked up about the house. Such things have been mentioned in these pages before, but there is no harm in repeating, for my younger friends, that match boxes, small cartons and things like cotton bobbins make quite good loads for a start.

As a miniature railway grows up, so do the owner's ideas on loads. There are various loads available in the Hornby range, of course, and the well-known Cable Drums and Containers, each on its Low-Sided Wagon, immediately suggest themselves.

Somehow a Container loaded on a miniature wagon always manages to look businesslike, and to include one or more in a train immediately makes it appear more important. The road part of the travels of a Hornby Container of course has to be provided for, but it looks just right on the deck of a Guy Flat Truck,

Dinky Toys No. 432, so that is settled.

Those of you who are Meccano enthusiasts will not need to be told that the Meccano Loaded Sack, Part No. 122, is quite a good thing for loading into Hornby Wagons. There is a wire loop at the top of the Sack that makes hoisting by crane an easy matter. Two of the accompanying pictures show the Sacks in use, and I am sure that you will agree that they look most effective.

An important traffic that is handled by

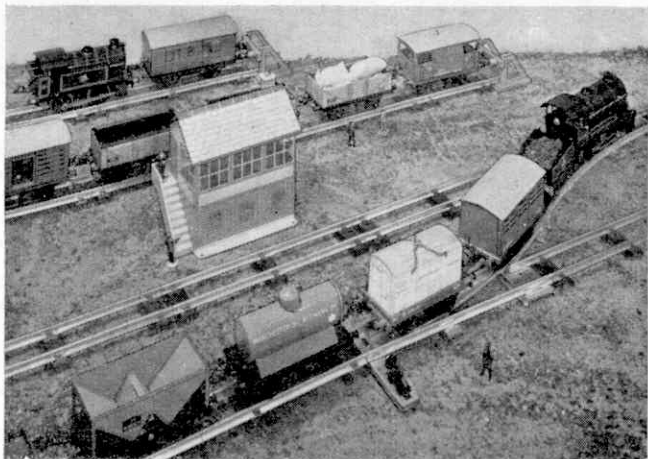

A goods train on a Hornby layout leaving a loop for the main line. The Insulated Meat Container on the second vehicle in the train makes an effective load.

rail is timber and it is really easy to arrange suitable loads of this kind. The miniature "tree trunk" that you can see in the lower picture on the next page is simply a piece of stick. In the illustration this is shown loaded over the end of an ordinary Open Wagon, as is often done in actual practice. But the Hornby System is well off for Wagons for this type of traffic. There is a Lumber Wagon for the rough tree trunks and so on, and also a Timber Wagon that is specially intended for the carriage of sawn timber.

By the way, don't hesitate to run a few empty wagons at times. On real railways there are occasions when empties have to be sent from one point to another, perhaps returning empties or wagons that are on

A train of empties takes the curve past the Signal Cabin. The engine is a No. 40 Tank.

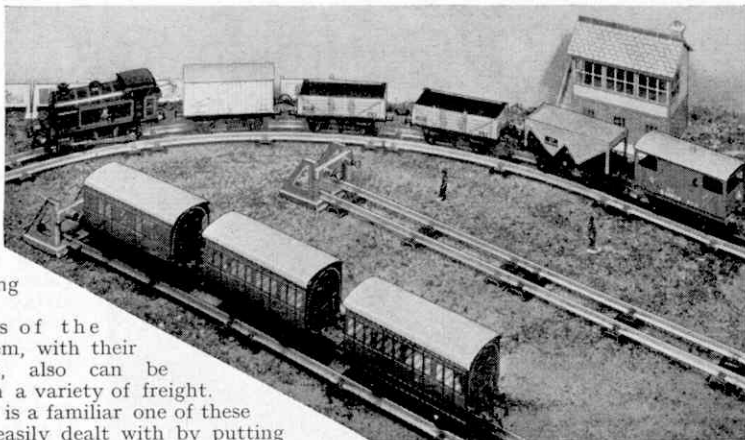

the run because they are wanted for loading up elsewhere along the line.

The Vans of the Hornby System, with their sliding doors, also can be provided with a variety of freight. The Milk Van is a familiar one of these Vans and is easily dealt with by putting several miniature Milk Cans in it. You can also use the Van for other loads as well, and the Cans themselves are useful for decorating station platforms. Real milk cans are often seen in such a situation, waiting to be sent off or to be collected for road transport.

Of the other Vans, the Cattle Truck has its own special purpose, as has the Refrigerator Van. The one most generally useful perhaps is the ordinary Goods Van, because it is suitable for such a variety of loads and can be run either in goods or passenger trains.

A pleasing touch is evident in two of the pictures here. You must have often seen a real van, standing empty in the sidings, with a door open, or partly so.

Well, don't overlook the doors of Hornby Vans. You can do the same thing with them, a little detail that will appeal to those of you on the look-out for novel oddments in the way of effects.

The handling of loads usually means that a Crane will have to be used for some of them. So put your Hornby Platform Crane conveniently near the Goods Platform. You can make good use too of the Goods Yard Crane, which is listed as Dinky Supertoys No. 973. This has the special advantage that the Crane jib can be raised and lowered as required, as well as the Crane Hook.

Very handy, too, for goods yard use is the Coles Mobile Crane, Dinky Supertoys No. 971, which can move about the yard between the tracks. It is a really fascinating business to drive one of these Cranes. With a little practice you can quickly become expert at manoeuvring it into the best position for carrying out the different lifting and slewing jobs that are necessary when wagons are being loaded and unloaded.

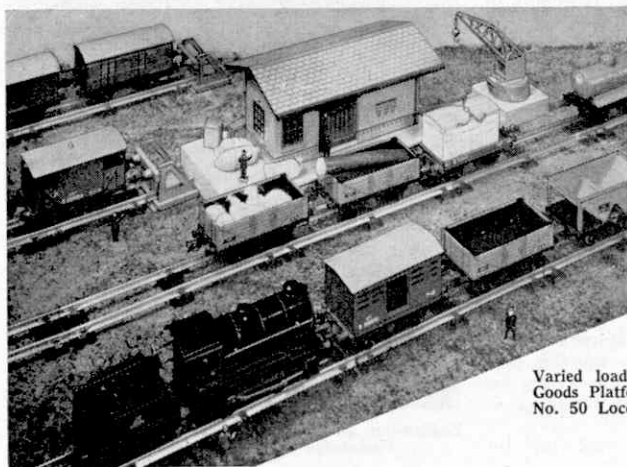

Varied loads are being dealt with at the Goods Platform, while in the foreground a No. 50 Locomotive is making up its train.

## Of General Interest



A scene in Barcelona. On the left is a replica of the *Santa Maria*, the vessel in which Columbus sailed on the voyage in which he discovered the New World. Photograph by Bernard Croft, Cranleigh.

R. S. Riddell, a reader of the Magazine who recently visited Denmark. While there he saw this bridge, which is of the lifting type, the two halves of the roadway rising when large vessels are to pass through. Warning that the bridge is about to be raised is provided by two red lights that flash alternately. These are similar to our own traffic lights in shape and setting, as a glance at the picture shows. The red lamps flash out their story, whether those crossing are thinking in English or in Danish.

THE picture of the replica of the *Santa Maria*, the vessel in which Columbus sailed westward on the voyage in which he discovered the New World, is a reminder of the *Mayflower II*, another replica of an old world sailing ship now being completed at Brixham, in Tor Bay. I do not know whether the modern *Santa Maria* has ever sailed the seas, but the British replica will actually cross the Atlantic, as the original *Mayflower* did.

The builders of the *Mayflower II* have devoted considerable time to searches through old time records, and in consultation with old sailmakers and retired shipbuilding craftsmen, to make certain that their designs followed those of the days of sail. Besides making certain in this way that the ship is historically correct they were concerned with her seaworthiness.

Now glance at the lower illustration on this page. The directions on the disc seem perfectly clear, and you may be surprised to learn that the language is not English, but Danish.

The photograph was sent me by



English—or Danish? Anyway, the meaning is clear. Photograph by R. S. Riddell, Totteridge.

## From Our Readers

*This page is reserved for articles from our readers. Contributions not exceeding 500 words in length are invited on any subject of which the writer has special knowledge or experience. These should be written neatly on one side of the paper only, and should be accompanied if possible by original photographs for use as illustrations. Articles published will be paid for. Statements in articles submitted are accepted as being sent in good faith, but the Editor takes no responsibility for their accuracy.*

### An Old Town Hall

It is not very often that we hear of someone pulling down a building and rebuilding it in another place, but this is what happened to the Town Hall at Leominster 101 years ago. It was then put up for auction and sold to a certain Mr. Arkwright for the ridiculously low sum of £95. Mr. Arkwright dismantled it and re-erected it about a mile away.

The handbill advertising the sale described the building in these words.

"This is one of the few remaining Timber Structures of the 16th century; it was erected by John Abel, the most noted Architect of his time. It is composed of Timber and Plaster, and adorned with curious grotesque figures, in a good state of preservation,



The former Town Hall of Leominster. Photograph by J. C. D. Smith, Bristol.

standing on 12 Oak Pillars of the Old Ionic Order, now sustained on Stone Pedestals. The upper part of the Building displays a profusion of Carving, and various Sentences are inscribed upon it."

J. C. D. SMITH (Bristol).

### Britain's Longest Pipeline

Loch Tay is the longest loch in Scotland, and the 4,004 ft. Ben Lawers on its northern bank is one of the highest mountains in Britain. Since the war, the North of Scotland Hydro-electric Board has been engaged on an enormous project in this district for generating electricity from the natural water power. At one time 800 men were at work. The "Lawers Scheme" as it is called, now produces 80 million units of electricity a year.

At the end of June, Lady Taylor, wife of the principal of Aberdeen University, officially opened the latest addition to the "Lawers Scheme." This is the power station at Finlarig on Loch Tay, near Killin. The accompanying photograph shows workmen putting the final coat of paint on the 5 ft. 6 in. pipe that carries the water from Loch Lawers, high on the mountain, down to the turbines at Finlarig. This pipeline, is 1,300 ft. long.

A. RILEY (Arbroath).

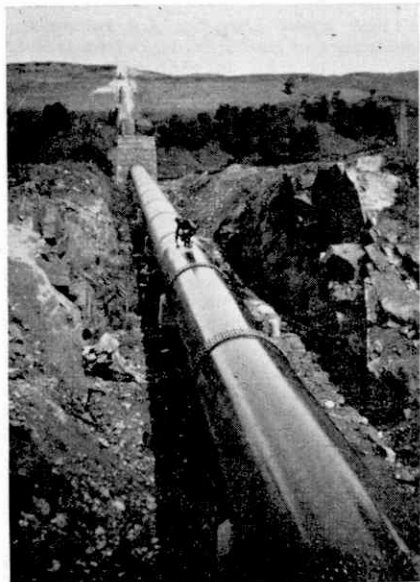

The giant water pipe carrying water from Loch Lawers to the hydro-electric station at Finlarig. Photograph by A. Riley, Arbroath.



## Blue Tits in Action

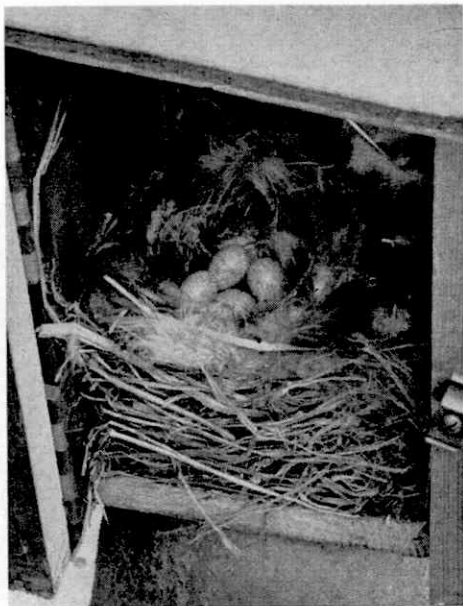

## Family Life in the Garden

By John Warham

I WAS sitting in the garden among the fruit trees. In front of me, and about four feet away, a small wooden box having a hole in the front about as large as a penny was screwed to one of the trunks. From within came a continual purring sound as 10 tiny nestling blue tits chattered among themselves while awaiting their next meal.

They had not long to wait. Suddenly one of the parents flicked from the nearby hedge into the branches, then dropped down to the box and in through the hole, a hole nicely tailored to fit his neat figure. The chorus swelled immediately he arrived, but subsided again when a minute or so later the bird's head popped through the hole. A brief glance around, and he was gone.

Although I was so near, the titmouse could not see me. I was concealed within a "hide" made of fabric fitted on to a framework, so that my notebook and camera could be used without my nearness being known. The bird's hasty departure was quite normal; with 10 young ones to be fed neither parent had time to loiter.

These frisky blue tits are among the commonest of garden birds, but we tend to see more of them in winter time. Then, with the trees and hedges bare of leaves, the tits are more obvious, while they also visit food tables and nuts and fat hung up for their benefit more at that time of the year. During hard winters especially, many country-dwelling blue tits move into the outskirts of the towns, where food is much easier to find.

Blue tits are colourful little birds, particularly the males, since these are brighter than their mates. They have white cheeks, blue crowns and tails, greenish backs and yellow breasts. There is a black band across the throat and a dark mark runs down the centre of their breasts; all in all they are exceedingly attractive, the more so since they are so alert and active, at home as much upside down as right side up.

Long ago all blue tits nested in the woods—as many still do—laying their eggs inside small holes in the tree trunks. But the forests have shrunk as man has multiplied and blue tits, being adaptable

The picture at the head of the page gives a peep inside a blue tit's home. This is a luxurious nest, built of ample material and comfortably lined with feathers upon which the eggs are cradled.

and go-ahead by nature, have found alternatives to their traditional nesting places.

Nowadays it is not at all unusual to see a blue tit settle on a gas standard in a street and suddenly disappear inside, for lots of these birds nest right down inside the hollow stems of the lights, which they enter at the top just below the mantle. Others



Above, a parent blue tit, bedraggled after bathing, pauses with a grub in his beak before flying to his nest in a garden box. On the right is a well-feathered chick impatiently awaiting his arrival with food.

rear their families in cavities beneath the eaves, in holes in masonry and suchlike places. But there seems to be a perpetual shortage of really desirable homes, and a properly made nesting box like the one in my pictures nearly always attracts a pair if it is placed correctly and out of the way of cats and similar hazards.

This was the second year that blue tits had used my box. This time the male was easily recognised, for he wore a leg-ring numbered BN 929 and inscribed *Return to British Museum, Natural History, London*. He was a bird I had caught in a baited trap over a year previously when I had been ringing and releasing all my garden birds, to see just which were residents and which were visitors from elsewhere. His mate was unringed; she was either a newcomer or one that had eluded my trap.

These two had begun their many inspections of the nesting box early in

February, but it was always the male that was most interested in it. Like other kinds of titmice, he used a special "hole inspection" display to draw his mate's attention to his discovery of a possible home for the season. He clung below the entrance and repeatedly turned round to look at his mate. Presently she responded to his invitation and flew down to inspect the place herself. Eventually, after many such visits, she seemed satisfied and towards the end of April nesting began. Now, however, the male took little interest in the box and left the female to work unaided.

She carried in a great deal of moss and many feathers. She also paid a number of visits to my "hide." This was made of hessian, and the titmouse discovered that by alighting near one of the peep-holes cut in the front she could tease out the raw ends of the fabric and use the fibres to line her nest. On each trip she flew off with a bundle of these held crosswise in her beak, looking as though she had grown a huge and most ungainly moustache!

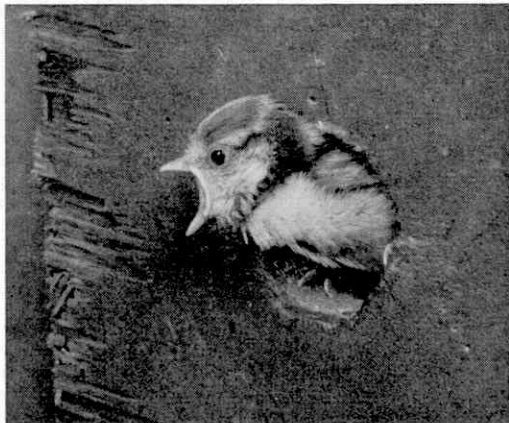

The first egg appeared, tiny, white and finely spotted with chestnut, and from then on the female remained inside after dark while her mate slept in the holly hedge nearby. Each night another egg was laid and early in the morning she would slip out to collect some more moss or fibre. This was laid on top of the eggs so that if I lifted the lid to peer inside none of them could be seen. Once the eggs had been

covered both birds kept well away from their home until sunset and it was time to retire.

This went on until eight eggs had appeared and then the female started sitting. At this stage she used an unusual threat display if disturbed, lunging forward with her head and making an explosive hissing noise. This is quite a startling performance if you are not expecting it, for it seems that a snake or something equally unpleasant is inside. No doubt this display is a bluff to ward off the unwelcome attentions of enemies like squirrels, jays and magpies. I imagine that it's quite effective.

For some time the brightly clad male had been feeding his mate, particularly when she emerged to stretch her legs. She was very persistent in begging from him, shivering her opened wings up and down and behaving just like a young bird

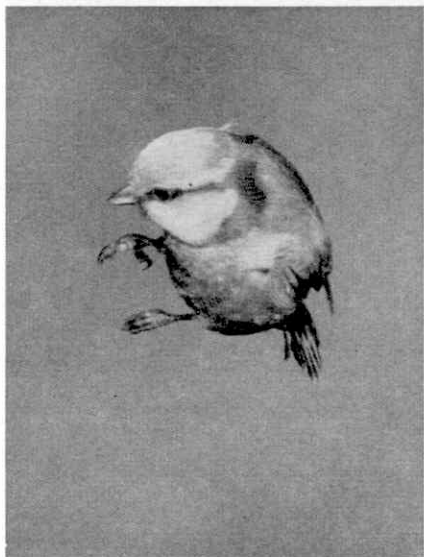

A blue tit coming in to alight has its wings completely closed for a moment. Perhaps it has overshot its perch.

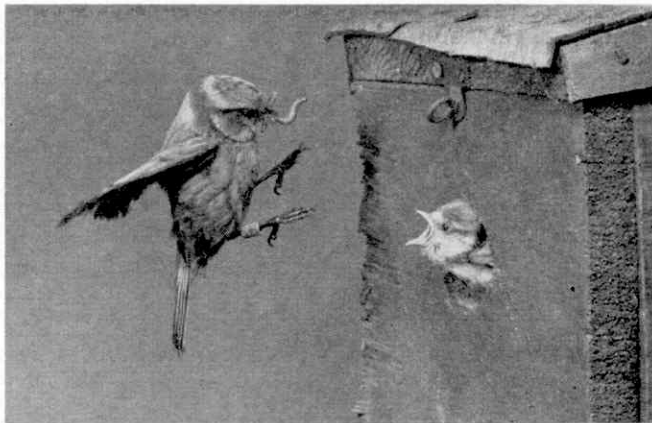

A fine action shot, at 1/5,000 sec., that tells its own story.

recently fledged. Later on she sometimes begged even when her beak was crammed with food she had collected for the chicks!

Altogether there were ten eggs, which hatched after about a fortnight's incubation, and both parents were soon working hard finding caterpillars for this large and perpetually hungry family. Sometimes between them they made as many as 400 trips in a single day.

All seemed to be going well and the chicks were growing splendidly when the female suddenly disappeared. She was never seen again and I suspect that some roving cat caught her while she was hunting for grubs for her family.

This was a serious setback, but the male stuck to his task and even redoubled his efforts. Soon he was looking rather the worse for wear, his plumage soiled and untidy, but he still kept on from dawn to dusk. By now one or other of the chicks was always at the entrance. The old bird had no longer to go inside for the food was snatched from his bill as soon as he alighted. When one chick had had its fill the next in the queue would push up to replace it.

Eventually seven of them were big enough to fly. I was watching when they left and saw the leader lean out so far that several times he could hardly get back again. And then it happened! He simply toppled out and flew off. Hard on his heels out poured the rest of them, and in no time at all they had all "abandoned ship" and joined the parent bird in the shelter of the hedgerow. Left in the box were the remains of the three chicks which the male had failed to rear—dead of starvation as a result of their mother's disappearance.

# Meccano Competition

## Start Preparing Your Entry Now!

LAST month we made the first announcement of the new General Model-Building Contest we have arranged for the winter months. This type of competition is always popular, as there are no restrictions of any kind on the subjects of the models, or on the number and variety of the parts used to build them. Thus every model-builder can take part in this contest, irrespective of his age or the size of his Outfit. The competition is open for three more months, so that Overseas readers can prepare and submit their entries before the closing date. The winter model-building season is already well under way, and now is the time to start building a model suitable for entry in this contest.

There are no entry forms to complete and the rules are very simple. All you have to do is to build an original Meccano model of any kind and let us have details of it. *The actual model must not be sent.* All we require are photographs or sketches of your model, together with any notes you consider necessary to explain points of special interest. Good clear photographs are preferable, of course, but if they cannot be obtained readily then sketches will do quite well. Your age, name and address must be written clearly on the back of each sketch or photograph you send.

Although model-builders are free to choose subjects of any kind it is advisable to select a model well within the scope of the Outfit you have available. The judges will look for neat and sturdy designs, and mere size alone will not ensure a prize. It is far better to build a small model really well than a large skimpy structure,

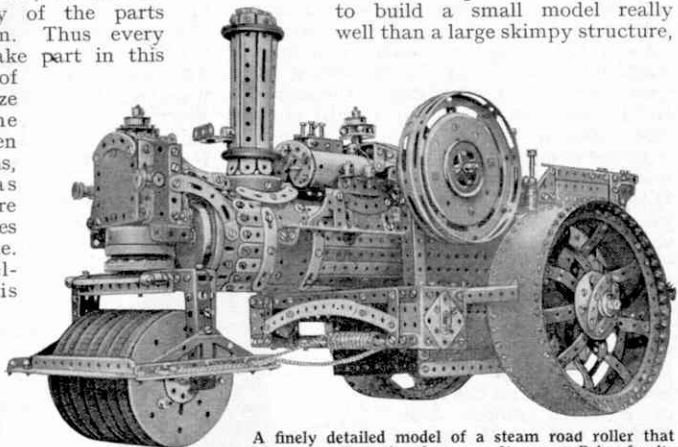

A finely detailed model of a steam road roller that has many attractive features. It won a Prize for its builder, Mr. J. Matthews, Fillongley, in a Meccano Competition some years ago.

so make sure you have sufficient parts available to build a strong and accurate model of the subject you select.

There are two Sections of the competition. Readers under 12 years of age on 31st January, 1957, are eligible for Section A, while entries from readers age 12 or over on that date will be placed in Section B. Entries must be addressed to *Winter Model-Building Competition, Meccano Ltd., Binns Road, Liverpool 13*, and they must reach us not later than 31st January next. Details of the prizes to be awarded for the best entries in each Section are given in the panel on this page.

Prize-winning entries become the property of Meccano Ltd. and are not returnable. Unsuccessful competitors can have the illustrations and details of their models returned to them providing they send stamped addressed envelopes of requisite size with the entries. All prize-winners will be notified by post as soon as possible.

### THE PRIZES

The following prizes will be awarded in each of the Sections A and B.

	£	s.	d.
First Prize, Cheque for ... ..	4	4	0
Second Prize, Cheque for ... ..	2	2	0
Third Prize, Cheque for ... ..	1	1	0
Ten Prizes, each of ... ..	10	0	0
Ten Prizes, each of ... ..	5	0	0

# Among the Model-Builders

By "Spanner"

## A Novel Use for the Meccano Worm Gear

Part No. 32, Worm Gear, is one of the most useful gears in the Meccano range, as it is employed in practically every case in which a large reduction in speed is necessary and the space available for the gearing is limited. With the Worm Gear a reduction ratio of 133 : 1 can be obtained in a single stage by meshing the Worm with a  $3\frac{1}{4}$ " Gear, while at the other end of the scale a 15 : 1 ratio can be obtained with equal ease using a Worm and a  $\frac{1}{16}$ " Pinion.

Its use in providing speed reduction ratios is of course the primary function of the Worm Gear, but another important use is as a small rack strip, and the value of the Worm in this connection is not always appreciated by model-builders.

In Fig. 1 a Worm Gear is shown mounted freely between a Collar and a Short Coupling on the shaft of a small model drill. Meshing with the Worm is a  $\frac{1}{4}$ " Pinion 1, which is mounted on a short Rod supported in the drill frame. This Rod carries outside the frame a convenient handle 2 formed by a long Bolt screwed into a Collar.

When the handle 2 is depressed the Pinion 1 drives the Worm downward, and as it is held

Fig. 1. This model drill provides a good example of one of the more unusual uses of Part No. 32, Worm Gear.

on the drill shaft between the Collar and the Short Coupling the shaft is made to slide down in its bearings. A Compression Spring on the shaft returns it to its original position when the pressure on the handle 2 is released.

This mechanism demonstrates also the value of the 4" Rod with Keyway included in the Meccano Gears Outfit 'B'. The shaft on which the Worm Gear is mounted is a 4" Rod with Keyway, and the Pulley 3 is made to



This cheerful model-builder is Michael Harris, who lives in London S.E.10 and is a very keen Meccano enthusiast.

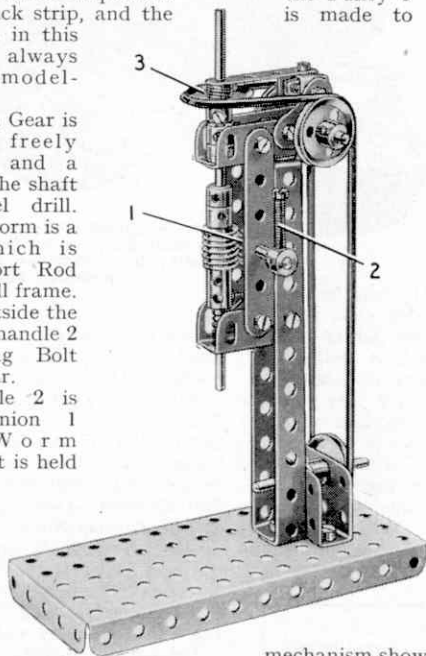

turn with the shaft by a Key Bolt screwed into its boss. Thus the drill shaft is able to slide in its bearings without affecting the belt drive to the Pulley 3.

## A Differential Operated Brake Mechanism

Mr. E. J. Benton, Lye, Worcestershire, wrote to me some time ago to tell me of experiments he had made in connection with an automatic brake mechanism for the winding shaft of a model crane. These experiments were designed to produce a brake that was applied immediately the drive to the shaft was disengaged, irrespective of whether the winding drum had been hoisting or lowering the load. Eventually Mr. Benton designed the differential mechanism shown in Fig. 2, and he tells me that it is most effective in action.

The drive from the model's power unit is transmitted through gearing to a 57-tooth Gear 1, which forms the crown wheel of a differential mechanism. The Gear 1 is connected by two  $1\frac{1}{2}$ " x  $\frac{1}{8}$ " Double Angle Strips to a Bush Wheel 2, but the Double



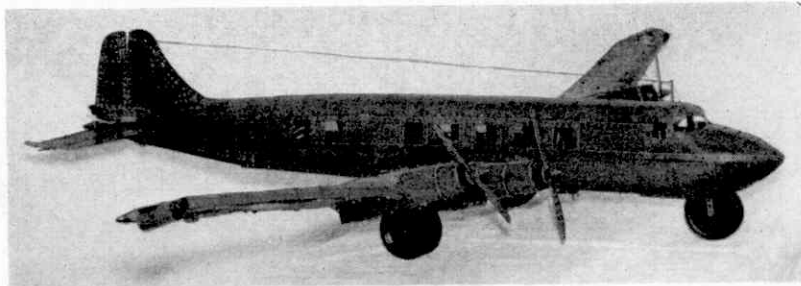

A fine model of a DC-6 airliner built by Mr. J. Kobus, Voorburg, Holland. It has working elevators, ailerons, rudder and propellers, and the fuselage is 5 ft. in length. The wing span is 7 ft.

Angle Strips are spaced from the Gear by three Washers on each Bolt. A 2" Rod is passed through one side-plate of the mechanism housing and through the boss of the Gear 1. A  $\frac{3}{4}$ " Contrate 3 is fixed on the Rod, which is then passed into the long bore of a Coupling 4. A 2" Rod fitted with a  $\frac{3}{4}$ " Contrate 5 is similarly passed through the other side-plate and through the Bush Wheel 2. Two  $\frac{3}{4}$ " Pinions 6 are placed on a 2" Rod, which is supported in the  $1\frac{1}{2}" \times \frac{1}{2}"$

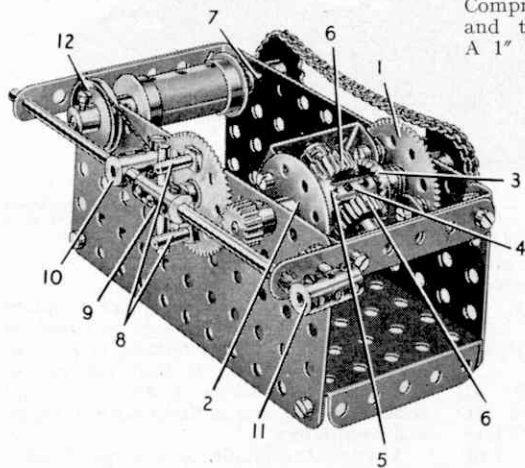

Fig. 2. A novel automatic brake for a model crane that depends for its action on a differential mechanism.

Double Angle Strips and passes through the Coupling 4. One of these Pinions is fixed on the Rod while the other should be able to rotate freely, and they both engage the Contrates 3 and 5.

A 1" Sprocket on the Rod carrying the Contrate 3 is connected by Chain to a

similar Sprocket on the winding drum shaft 7. The Rod carrying the Contrate 5 is fitted with a  $\frac{1}{2}"$  Pinion that engages a 57-tooth Gear mounted on a Pivot Bolt that is fixed to the housing. Two Threaded Pins 8 are held by their nuts in the 57-tooth Gear. The Threaded Pins bear against a  $1\frac{1}{2}"$  Rod fixed in a Coupling 9, which carries also two  $3\frac{1}{2}"$  Rods free to slide in Strips bolted to the housing. One of the  $3\frac{1}{2}"$  Rods is fitted with a Coupling 10, and the other carries a Coupling 11 with a Compression Spring between this Coupling and the Strip serving as the bearing. A 1" Rod held in Coupling 11 is passed through a hole in the Strip and serves to prevent the assembly from rotating.

The action of the mechanism is as follows. A length of cord is passed round a 1" Pulley 12 on the winding shaft and is tied to the Coupling 10. The Compression Spring between Coupling 11 and the Strip tends to tighten this Cord round the Pulley to form a simple band brake. When the drive is disengaged this brake prevents the winding shaft from turning. As soon as the drive is engaged however, the differential mechanism is brought into action and the Gear carrying the Threaded Pins tends to rotate. The Threaded Pins then press against the  $1\frac{1}{2}"$  Rod in Coupling 9 and slide this Coupling and the

Rods it carries against the pressure of the Compression Spring. The Cord round Pulley 12 is thus slackened and the brake is released. The brake is automatically re-applied as soon as the drive is disengaged. Thus a separate brake lever is unnecessary and the controls are much easier to arrange.

## MODEL OF THE MONTH:

# Floating Crane

OUR model this month is based on a type of crane used very frequently in ports and shipyards. Although large land cranes can be used for much of the work in connection with harbours and ships, their range of movement is comparatively limited, and sometimes it is impossible to move them into the best positions for handling certain loads. In these cases a floating crane is invaluable, and indeed essential, for in docks and harbours it can be manœuvred readily into the most suitable position to tackle the work to be carried out. Indeed, sometimes when heavy machinery, or perhaps a funnel, has to be removed from a ship it is possible to carry out the job without docking the vessel.

The efficiency and adaptability of floating cranes has been recognised for many years by dockyards, shipbuilding firms and harbour authorities, and nowadays there are many very fine floating cranes at work in ports and shipyards all over the world. Some of them are capable of handling exceptionally heavy loads, and lifting capacities of 200 tons or more are by no means unusual. In most cases these floating cranes are fitted with propulsion engines and all the auxiliary equipment required to enable them to operate under their own power, while in others the cranes are mounted on unpowered pontoons

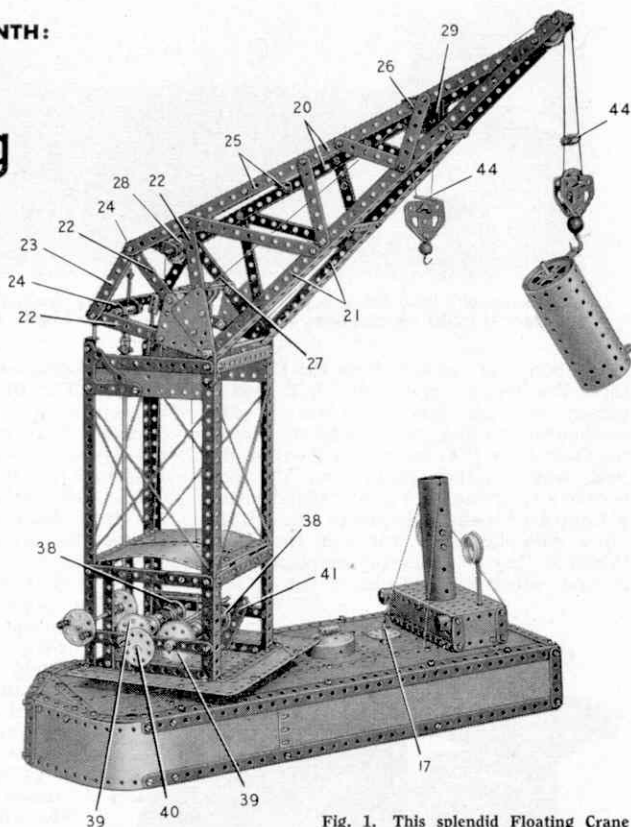

Fig. 1. This splendid Floating Crane makes a fine model for owners of a No. 8 Outfit or one larger.

and must be towed from place to place by tugs. The Meccano model is based on a self-propelled type of floating crane, and the hull or pontoon is provided with a structure representing a deckhouse and control bridge, and is fitted with a funnel and ventilators.

A typical example of a large floating crane is the *Mammoth* owned by the Mersey Docks and Harbour Board. This fine crane can handle loads up to 200 tons, and one spectacular job it carried out was the transport across the River Mersey of part of a lock gate weighing 190 tons. This gate was taken from the Alfred Dock, Birkenhead, and was carried by the crane across the river to the Brunswick Dock, Liverpool, for repairs and strengthening. After the work had

Fig. 2. An underneath view of the pontoon of the Floating Crane, showing the slewing mechanism.

been carried out the *Mammoth* again transported the gate and replaced it without difficulty.

The Meccano model is based on a typical large floating crane of the kind seen in use at many harbour installations. The hull or pontoon is constructed mainly with Strip and Angle Girders, and the section of the deck that

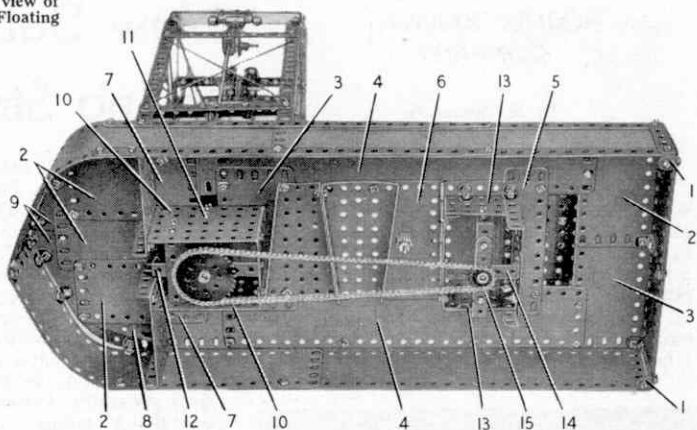

supports the crane is strongly braced. The crane jib is mounted at the top of a tower that is pivotally attached to the deck of the pontoon. The jib can be luffed, or raised and lowered, by turning a handle mounted in the tower. This handle controls a screw mechanism that operates the luffing movement of the jib.

The model has two lifting hocks, and an interesting feature is that the same control handle is used to operate the movements of both of them. The shaft on which the control handle is fixed is free to slide slightly in its bearings, and gear mechanism is used to engage the drive with either of the two winding drums. The slewing or rotating movement of the crane tower and the jib is controlled by a separate handle placed on the pontoon close to the deckhouse.

The Meccano Floating Crane is designed for construction with parts in a No. 8 Outfit. Full constructional details and a list of the parts required to build the Crane can be obtained by writing to the Editor, enclosing a 2d. stamp for postage. Cranes are always popular subjects for Meccano models, and there is sure to be a big demand for details of the Floating Crane.

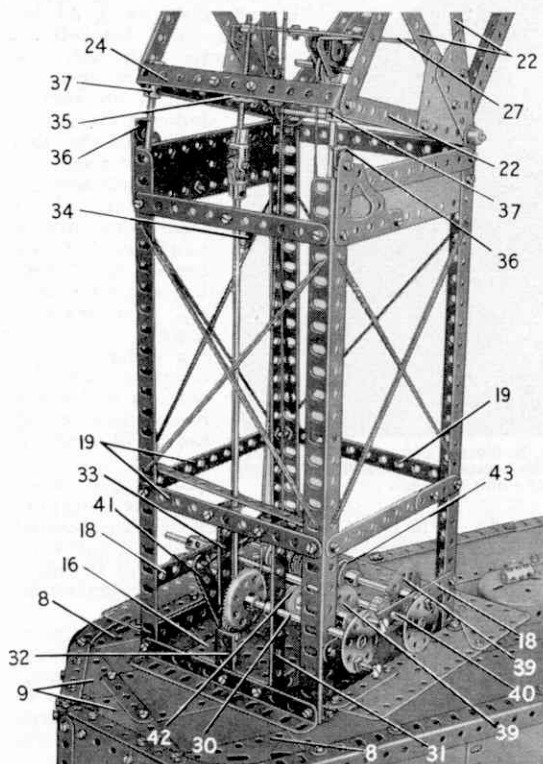
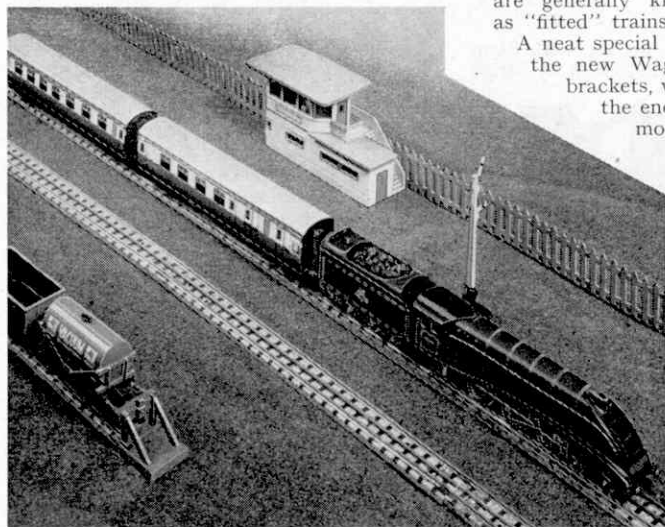

Fig. 3. A close-up picture of the tower revealing details of the control handles and the gearing.

## HORNBY RAILWAY COMPANY

By the Secretary

A MONTH or two ago, you will remember, I told you that there would be further developments in the Hornby-Dublo range and I am glad to say that two of the new items can be mentioned in our talk this month. What these are you will gather from the pictures on the next page, which I am sure you look at before you begin to read what I have to say.



The Hornby-Dublo "Silver King" speeds past the Signal Cabin with a train of D12 Coaches. These vehicles are now included with this Locomotive in the ED15 Passenger Train Set that was introduced a little while ago.

I expect that most of you will already have seen one of these additions, the Hornby-Dublo 20-ton Tube Wagon, for this actually made its appearance during October. For quite a long time now many of you have been pressing for the introduction of additional Wagons, preferably something four-wheeled that would have a "different" look from the other four-wheelers already in the range. Well, the Tube Wagon is the first of several vehicles of this kind and I know that it is being greeted with enthusiasm.

A very striking feature of this vehicle

## New Dublo Rolling Stock

is its length, which helps to give it a very "real" appearance. For this a new base has been designed. The usual details of dummy axle boxes and springs, and the channel section of the underframe side members, are all there. As the Hornby-Dublo model reproduces in miniature a tube wagon of modern construction it represents a brake-fitted prototype, that is one with automatic vacuum brake gear, making it suitable for running in what are generally known on the railway as "fitted" trains.

A neat special feature incorporated in the new Wagon concerns the axle brackets, which, as usual, support the ends of the axles. In this model these brackets do

more than this, for they are specially formed so that a representation of the brake blocks and hangers fore and aft of each wheel is included. This makes for additional realism "down below" and, with the space provided by the extra length we have taken the opportunity of adding representations of the brake cylinder, and of the "V" hangers that in real practice support

the brake shaft. At each right-hand corner of the Wagon, as you view it sideways, there is a fine representation of the short hand-brake lever used by brakemen when shunting is going on.

The design of the body of the vehicle, in printed tinfoil, represents a B.R. tube wagon four planks deep with the strapping, hinged door details, corner plates and so on. This long-bodied Wagon presents splendid opportunities for those who like providing miniature loads.

Some of you may have already wondered what are the miniature tubes that can be

Loading the new Hornby-Dublo Tube Wagon. What the "tubes" are is explained on this page.

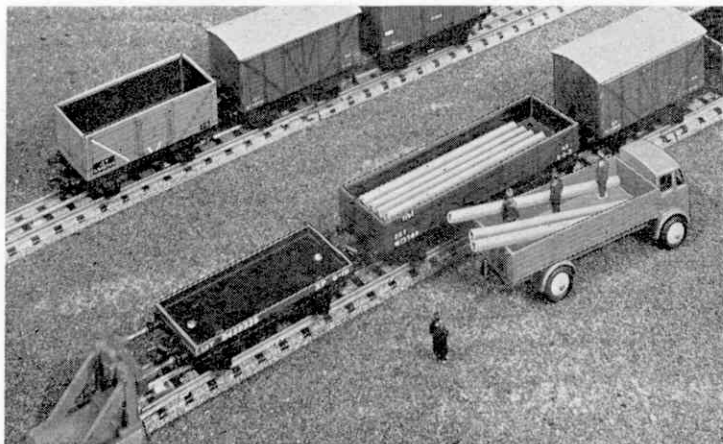

seen in the accompanying illustration. They are in fact pieces of drinking straws, cut to suitable length. You will probably discover some of these at home, but if not, they are readily bought, and quite cheap. They can be cut easily with a pair of scissors, or those of you who are aeromodellers may prefer to use one of the special modelling knives that are so useful to you in that and other hobbies. Don't cut your fingers—or the table cloth! Put the straws on a board or stiff piece of linoleum.

I have news, too, of another vehicle, a Ventilated Van. Some of you may not have seen it yet, but it is due to make its appearance this month. It is shown in the lower of the two pictures here, and there will be no need for me to tell Western Region enthusiasts what it is.

This Hornby-Dublo Ventilated Van is another long wheelbase job, and represents in a remarkably attractive manner the vehicle familiar under the old G.W.R. code name of *Mink D*, and so well known in Western Region freight and passenger trains. It can run in passenger trains because it is brake fitted, as the Bauxite colour of the bodywork of the Hornby-Dublo model indicates. Actually the brake pipes are represented in the tinprinted details on the ends of the vehicle and in fact all the characteristic features of the bodywork are reproduced. The usual tonnage and numbering details appear in white lettering on black patches as is usual, and the *XP* indication found on fitted vehicles towards the right hand end of each side is of course included, as well as the tare or empty weight of the Van.

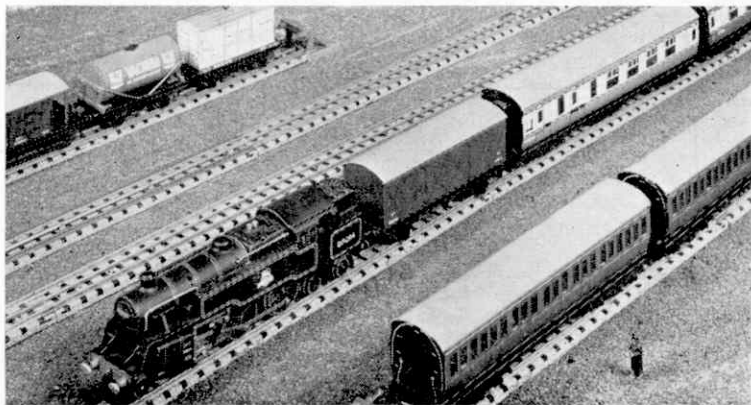

The new long wheelbase Ventilated Van looks very well behind the engine of this semi-fast train. The Van can be used in passenger or freight trains.





A good view across the layout of Mr. C. J. Watkins, showing the bank of switches behind the platform in the foreground.

## Portable—But Precise

### A Neat Hornby-Dublo Main Line Railway

ALTHOUGH the railway shown in the plan and in the pictures on this and the next page looks permanent enough, the owner, Mr. C. J. Watkins, of Clapham, S.W.7, quite correctly describes it as a portable railway. In this sense it continues the idea behind the original small oval track with which operations began some seven years ago.

The railway is "portable" because the baseboard, which is 8 ft. 10 in. long and 4 ft. wide, is made in two parts, so that the railway can be dismantled when necessary. Matters are so arranged that the rails bridging the joint of the two boards are detached when the two sections are parted and they have to be slipped into place again when the two halves of the board are assembled for train working. This is an arrangement

that is being used to an increasing extent by Hornby-Dublo owners. Careful workmanship in the construction of the baseboard in the first place, and the subsequent assembly of the track, are of course essential.

Pleasing variety has been obtained in the arrangement of the two main stations. The Hornby-Dublo Station and the Island Platform are used to form the opposite sides of the main station *Crawford*, where controls for the whole of the track are located. Platform Extensions have been useful in making up a station that can accommodate three or four coach trains complete; and the off-setting of the main

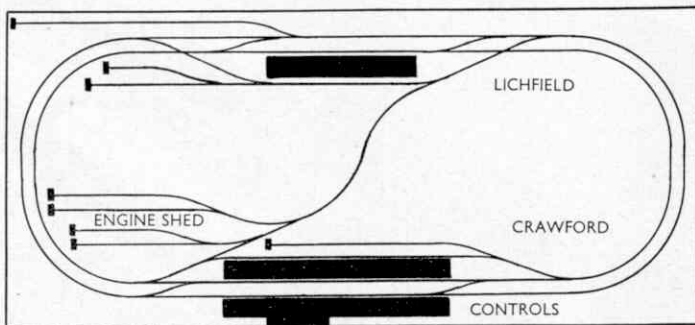

A diagram of the layout described in this article.

The Signal Cabin and Engine Shed tracks at "Crawford" appear in this picture, with realistic road effects.

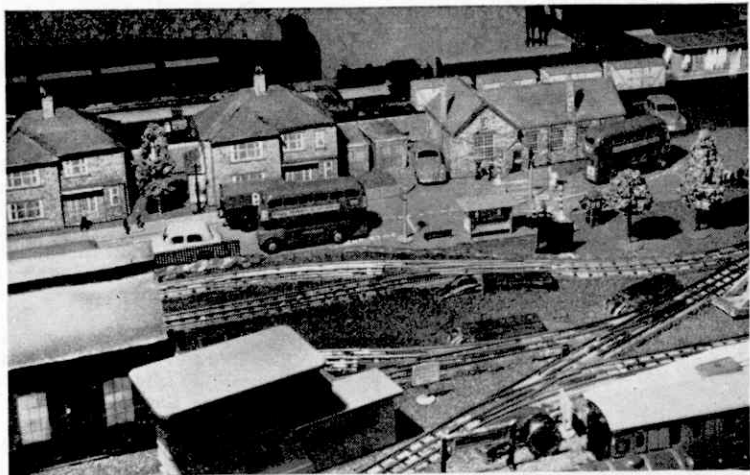

building section of the Through Station towards one end, instead of having it in the centre of the platform, has made it possible to place a series of Switches for controlling Isolating Rails and Points and Signals behind the extended platform.

These Switches make up a really impressive lever frame, as can be seen in the picture opposite. This is not surprising when we find that the railway incorporates 23 Electrically-Operated Points and 12 Electrically-Operated Uncoupling Rails.

A roadway runs through the centre of the line and this has provided the opportunity of incorporating the well-known Hornby-Dublo Level Crossing. The roadway, which curves in a realistic manner, has to cross the S-shaped length

of track forming a link between the two sides of the railway.

Hornby-Dublo Diamond Crossings have been applied in an interesting manner at *Lichfield*, as the diagram shows. The first allows a train on the outer track to be looped round the inner side of the Island Platform. The second, at the right hand end of *Lichfield* station, as you look at the diagram, helps to make it possible for a train approaching *Crawford* correctly on the inner track to be diverted right across the system, and to make its way on to the outer track and be reversed in direction when it rejoins the main line.

Actually the more or less diagonal track in the centre of the layout is a most useful feature, for the engine shed roads and platform loops at both Stations branch out from it. It provides a ready means of reversing Locomotives that have to be turned round before their next trip, a fact that is no doubt welcomed by any Hornby-Dublo "spotters" who haunt the Level Crossing.

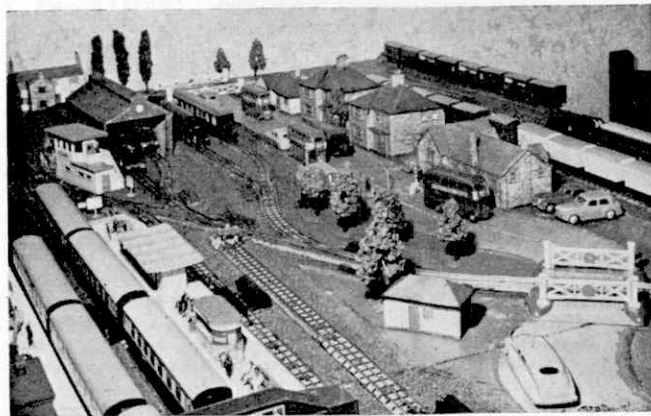

The Hornby-Dublo Level Crossing is prominent on the right hand side of this view showing part of "Crawford," the Engine Shed, and other features.

# Hornby-Dublo in the Country

**D**ONALD PEARSON, of Chesham, and Mr. P. W. Wallis, whom you see in the picture on this page, are quite proud of the Hornby-Dublo Railway they have built up together. They have good reason to be. Their layout is very effective indeed from the railway point of view and its surroundings are very fine, for the line passes through a well-arranged and remarkably complete

In addition to the main line stations, there is what may be termed a branch line terminus. The track leading to this is taken off the S-shaped diagonal track that joins the opposite sides of the inner main oval. Hornby-Dublo Stations and home built structures are used together, and as a result of careful attention to detail the final result is quite pleasing.

Roadways and a river make their way through the countryside, which is correctly fenced off from the railway property. Miniature houses and other buildings are provided and these have a very natural look, as can be seen from the illustration, because they are not arranged in too geometrical a manner, but follow the contour of the road. A few touches of this

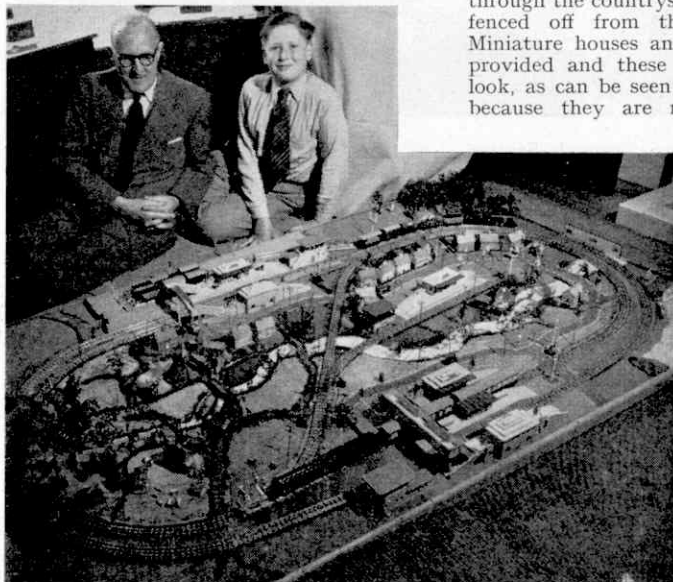

Donald Pearson, of Chesham, and Mr. P. W. Wallis, with the Hornby-Dublo layout that they have built up together. The railway has its own baseboard, which is constructed in two halves. Photograph by Grahame Studios.

countryside, although the whole layout is only 7 ft. long and 4 ft. 3 in. wide. After all, real railways run through a lot of "country," so it is quite right for a miniature line to do this.

The base on which the railway is laid is of stout construction and as the board is normally used on the floor, the provision of a protective beading all round the edge is a wise precaution.

There are two main lines, practically parallel throughout their length, and they serve two stations, one on each of the longer sides of the board. The station that is nearest the two Engineers in the picture has provision for goods traffic, but the other one deals with passenger trains only.

kind make all the difference to the realism of a layout.

Engineering and lineside effects include a tunnel at one end of the board, while further variety is provided by a small seaside section in one corner. This can be just seen in the right hand side of the picture, a narrow strip of "beach" with typical huts separating the line from the "sea".

Telegraph poles, correctly wired, follow the track and they are found along roadways as well. Most of the scenic and lineside effects have been built up at home from simple materials such as thin wood, card and so on, although in one or two instances ready-made parts have been employed. Home construction has, however, been carried out particularly well, so that the different items blend together perfectly.



# Club and Branch News



## WITH THE SECRETARY

### MORE MECCANO MODEL-BUILDING

By now Clubs and Branches have settled down again to indoor activities, and letters reaching Headquarters from Leaders and Chairmen tell of interesting and varied programmes being carried on. Too much variety, of course, tends to scatter the interest of members, and the Session ends with nothing much having been accomplished in any one direction. So I am pleased to note that one or two Clubs whose activities have been on the lighter side are this winter giving more time to Meccano model-building. This wise step will bear fruit in better and bigger models by the members as a team or teams, and will allow more time for guiding junior members in the construction of progressively more ambitious models.

### H.R.C. BRANCH RECENTLY INCORPORATED

No. 561, St. Kevin's College (Melbourne)—Mr. M. A. Saunders, 6 Ash Grove, East Malvern S.E.5, Melbourne, Victoria, Australia.

### FORTHCOMING EXHIBITION

The Norbury Transport and Model Railway Club, which includes the Norbury M.C., will hold their Annual Exhibition on Saturday, 17th November next, at St. Stephen's Church Hall, Winterbourne Road, Thornton Heath, Surrey, from 2.30 p.m. until 8 p.m. There will be many working model railway layouts, and stands of transport interest.

Prices of admission: Adults 6d.; Children 3d.

## CLUB NOTES

LAUNCESTON M.C.—The Club were favoured with a fine afternoon for their annual outing, which this year was a visit to Paignton Zoo and Goodrington Sands.

It is intended during the Winter Sessions to concentrate on practical activities rather than have a programme mainly of entertainment value, although lighter items will not be neglected. Secretary: B. Tunbridge, Tower Hill House, Box's Shop, Launceston, Cornwall.

ST. THOMAS DISTRICT (EXETER) M.C.—Members joined with those of Exeter M.C. in an outing to Barley Cope. The Club Meccano Outfit is being repaired, so model-building is being carried on with Outfits belonging to members. Hornby-Dublo operations have continued. Club roll: 15. Secretary: B. Madge, 42 Duckworth Road, Exeter.

CONSETT & DISTRICT Y.M.C.A. M.C.—Outings during the late summer included Pontop Pike B.B.C. Television

Transmitting Station, and the annual Traction Engine Rally at Chester-le-Street. Members have been busy preparing for the Club's part in the Consett Annual Show, the main items for their display being the model colliery and a model of the Eiffel Tower. The Club railway is to be modified and extra sidings added to give access to a proposed by-product plant and steel works. Further electrification will be carried out as funds permit. Construction has begun of a Hornby-Dublo layout that will be used for Exhibition purposes. Club roll: 25. Secretary: B. Ward, 10 Cyril Street, Number One, Consett, Co. Durham.

MILE END (PORTSMOUTH) M.C.—An attractive winter programme has been prepared. The Club took part in the associate Mile End H.R.C. Branch's Model Railway Exhibition, in which A. Firman's Meccano Robot, 4 ft. tall, with moving head and arms and "flashing" eyes was very popular. There was a fine variety of model railway layouts in operation. A profit of £3 was made. A reporter from a local newspaper visited the Exhibition, and spoke well of it. Club roll: 30. Secretary: Mr. A. J. Nicholson, 213 Sultan Road, Buckland, Portsmouth.

EXETER M.C.—At a Directors' Meeting John Cotsell proposed that the Club provide a shield as an award in football competitions, and at the end of next season present it to a team which had failed to get to the top and yet deserved some form of recognition. The shield was made by the father of one of the Club Directors, and at a special meeting in August last it was presented by J. Cotsell to the "Meccano Gunners" team of St. Thomas District M.C. who won a football knock-out competition last season. The presentation took place at Mr. Hodder's house with all the team present, and the event was "taken" by a local photographer. Exeter M.C.'s own team *Meccano Rovers*, are in good form for the coming season. Club roll: 20. Secretary: P. Phillips, 12 Alpha Street, Heavitree, Exeter.



Officials and members of the Cape Peninsula M.C., South Africa. On the extreme left is Mr. F. Korck, Chairman, with R. Borden on his left. Farther along the back row and almost immediately behind C. Cohen, the tall member wearing glasses, is Mr. Z. A. de Beer, the Leader; and on the extreme right of the back row is P. Simpson, recently elected Secretary in succession to K. M. Liebbrandt, who is standing next to the Leader. On the trestle table in front of the group are some of the fine models built by the members for the Club's 1956 winter model-building competition.

## BARGAIN Q.E. DISCOUNT APPROVALS!

You receive on approval a large selection of Q.E. and modern issues per return post if you send for our BARGAIN Q.E. DISCOUNT APPROVALS—we pay outward postage. Sets and singles at moderate prices less a generous discount and a host of other issues. Br. Colonials only or Br. Cols. and Foreign Mixed available. These are REAL collector's approvals! Get your selection today and see the difference!

**THE BIRKDALE STAMP CO.**  
104 Liverpool Rd., Southport, Lancs.



Postal Business Only  
(NO CALLERS)

**MONACO  
OLYMPIC  
GAMES SET**  
& Grace Kelly Wedding stamp

ABSOLUTELY

**FREE**

Yes, we will send you these super, multi-coloured giant commemorative Monaco stamps, ABSOLUTELY FREE! Just think—a set of three beautiful DIAMOND SHAPED 1952 OLYMPIC GAMES stamps, AND the famous "Wedding of the Year" Film Star GRACE KELLY-PRINCE RAINIER special issue that was on sale for ONE DAY ONLY! Just ask to SEE our popular NEW approvals (No need to buy anything!), and enclose 2½d. stamp towards postage.

**PHILATELIC SERVICES**

(Dept. M.M.16)

Eastrington, Goole, Yorks.

**MODERN UNSORTED LOTS ON PAPER.** All contain large Picts. Br. Empire 1 lb. (3,000) 2/-, ½ lb. 13/6, 4 oz. 7/3. World Assortment (wonderful value) 1 lb. 2/1, ½ lb. 1/1, 4 oz. 6/- Gt. Britain worth sorting for "finds", 1 lb. 5/6. Per 4 oz. Aust./Canada 4/9. N.Z./S. Africa 6/9. List Free. Post U.K.: 8d. lb., Abroad 1/3 lb.

**A. DAVIES (M/11), 3 Manor Road, Wroxall, I.O.W.**

## 100 DIFFERENT STAMPS FREE

To Approval Applicants enclosing 2½d. postage.

**N. JOHNSON (Dept. MM), 19 HILLSIDE, SLOUGH, BUCKS.**



For other Stamp Advertisements see also pages 594 and xx

## SERIOUS COLLECTORS

ARE ADVISED TO REQUEST A SELECTION OF MY APPROVALS STATING THEIR CHIEF INTERESTS. A POSTCARD WILL BRING YOU AN ATTRACTIVE LOT FOR INSPECTION.

H. B. LANG, Burnbank, Mauchline, Ayrshire

## 6 BRITISH GUIANA 6 FREE

ALL PICTORIALS

Send 2½d. stamp for approvals priced from ¼d. each.

**G. C. ANSON**

9 Squires Court, Finchley, London N.3

## FREE!

ANOTHER FINE NEW  
ISSUE PACKET

This month we offer a fine lot of **SPORTS** stamps including some of the very latest Olympic stamps to celebrate the issue to commemorate the **MELBOURNE GAMES**. A really attractive lot—not to be missed—and offered **quite free** to introduce our service to new collectors. Just send 2½d. for postage and price list. Write today to **CAPT. M. CAMPBELL & CO. (Dept. MM), 58 High Street, Watford, Herts.**

## 50 PICTORIAL STAMPS FREE

To all Genuine applicants for my used British Colonial Approvals enclosing 2½d. stamp. Overseas applications invited.

**D. L. ARCHER (M), 61 Whitley Rd., Hoddesdon, Herts.**

## 10 TRIANGULARS 10 ▲▲▲ FREE ▲▲▲

This fine packet of 10 Large Popular Triangular Stamps will be sent **FREE** to all new Applicants for "Alexandra" Approvals. All approvals contain a good selection of Colonial and Foreign stamps at lowest possible prices. **DO NOT MISS THIS OFFER.** Send **NOW**, enclosing 2½d. stamp for postage.

**ALFRED A. COOKE**

56 Buckleigh Avenue, Merton Park, S.W.20

## 9 SPORTS INC. MELBOURNE OLYMPIC COMMEM. FREE WITH QUALITY OR PRICE 1/3d. APPROVALS WITHOUT APPROVALS

Send 3d. (Abroad 6d. extra) for our postage. Monthly selections a speciality. IF you wish you may join "THE CODE STAMP CLUB". Sub. 1/- . Approvals sent monthly. Personal attention. (Postal Section Est. 1897).

**WRIGHT'S STAMP SHOP, Canterbury, Ltd.  
(M.20), Canterbury, Kent**



# Stamp Collectors' Corner

By F. E. Metcalfe

## GROUP COLLECTING

I HAVE tried to explain already how and why collecting stamps of all countries, or general collecting as it is called, is no longer feasible, if one proposes to form a collection on serious lines. In these days the flood of stamps impels one to limit the scope. But providing this limitation is carried out in an intelligent manner, and in line with one's taste and inclinations, it is possible to get at least as much fun out of the hobby as was ever possible, in spite of this multitude of new issues.

The only sensible way of forming a collection today



is to take up a group of countries, or even an odd country. Alternatively, one can go in for collecting a theme, but I will refer to this later. I suppose that Great Britain is about the only country of importance where collectors do not, first and foremost, collect the issues released by their own Post Office. Some do, of course, but the majority do not, and to some extent a glance at the catalogue provides an answer. Some time ago, when the question of pictorial stamps was being discussed in the House of Lords, there was talk about maintaining the tradition of the present style. A glance at the catalogue shows how little, from an artistic standpoint, the designs of our stamps deserve to be retained.

It is true that the Penny Black is interesting enough—one collection recently broken up was said to contain over 90,000 copies—with the result that though it is one of the commonest stamps, as far as numbers existing are concerned, good copies are beyond the reach of the average young collector. But apart from the Penny Black, and its companion the Twopenny Blue, the majority of British stamps are dullness itself as far as the designs are concerned. As they have

been the prey of specialists—I never did understand why those specialists who collect hundreds of a particular stamp should be considered, as they often are, as philatelic benefactors—our stamps are mostly difficult to get hold of in nice condition.

Now the new stamps for Scotland, Wales, etc., are going to make a big difference, for it is almost certain that these will only be the forerunners of other new stamps, and pictorials also are pretty certain to come in the long run. So I would urge all collectors to go in for our own stamps, if only as a side-line. Start on simplified lines. Look out for really nicely cancelled



of fun as your collection grows.

I saw once a Great Britain collection of common used KGV and KGVI, in which the collector had tried to get a stamp with a postmark of every day from the date the particular stamp was issued. All very trivial, if you like, but I am sure that the collector got as much fun out of his effort as some of those rich collectors get out of spending thousands of pounds on stamps, and he had only spent coppers. My own little side-line collection of G.B. consists of the finest used copies I can come across of each of the British stamps issued from the day the first KGV stamp was issued. I often change what I have for something better which comes my way. I do not suppose that I have spent above a couple of pounds on the lot, but I would not part for ten times that sum, and the fun I have had, and will have, makes me want other collectors to have a go on similar lines.

That is just one right way to collect, however. What I would urge new collectors to do is to study our own British stamps carefully, think out a way of collecting them to suit their pockets and tastes, and then go right ahead, bearing in mind that for the reason given there is probably a great future ahead for the stamps concerned.

So taking care to only collect fine copies, even if one does spend a little more cash than one would like to throw away on a hobby, the outlay is not likely to be wasted when the stamps come to be sold. But here let me state clearly that stamps as an investment for the average collector are *not* a good proposition. So collect for fun only if you do not want to be disappointed. This does not mean to say that stamps have no resale value. It is the profit that is not likely to materialise.

Apart from collecting our own British or Commonwealth stamps, the most popular form of stamp collecting is on themes, or what the Americans call topical lines. I think that this form of collecting is worth an article to itself. Actually I very much dislike the synthetic word thematic, but it is now in general use, and I suppose we have no option but to use it.

The most popular group of stamps with British collectors are those of our own Commonwealth issued during the reigns of the late Sovereign and his daughter Queen Elizabeth. These I will discuss later. Meanwhile, let me give another warning against collecting any old thing. As for collections worth thousands of pounds, the royal road to enjoying the hobby to the full does not lie by way of a big bank balance.

More about the groups next month.

copies. Never mind if the stamps are common, so long as they are really fine used.

For instance, there are thousands of KGV stamps knocking about. Get a loose leaf album—I will explain about the various kinds of albums later on—and if you only go in for the commonest of stamps, providing they have nice postmarks, you will get an awful lot





## GRACE KELLY WEDDING STAMP



## GIANT IMPORTED COLLECTION

FEATURES:

**MONOCO—GRACE KELLY WEDDING STAMP.**  
 SP. GUINEA—Monkiest Monkey family. CHILE—Magnificent "Cristo de los Andes." JAP OCCUPATION OF SHANGHAI—Map set complete!!  
 UNIQUE SE-TENANT SHOWPIECE—2 different STAMPS IN A GENUINE JOINED PAIR. RED CHINA imperf.; STALIN—Death Stamp; SOUTH POLE Expedition Seals; AUSTRIA—"Express" set. Dozens of other fascinating items. You'll have days of fun just sorting this giant lot. Grand total 214 all different stamps from all over the world. Guaranteed Catalogue value 25/6—all yours for just 1/- to introduce our Bargain Approvals. Money back if not delighted!!

**FREE! MIDGET ENCYCLOPEDIA OF STAMPS, STAMP DICTIONARY AND IDENTIFIER. SEND 1/- TODAY. ASK FOR LOT MC13.**



486 OLD KENT ROAD, LONDON S.E.1

**BRITISH** Colonial, Foreign, Stampfillers, 15 a 1d. Pictorials, Commemoratives, Colonials, Foreign, 1d., 1/2d., 1d. Postcard secures hundreds approvals.

PILGRIM

25 Alton Road, Wallisdown, Bournemouth.

## 5/- GT. BRITAIN Q.E. II FREE

THIS NEW QUEEN AND CASTLE STAMP SENT FREE TO ALL APPLICANTS FOR OUR MODERN COLONIAL APPROVALS ENCLOSING 2½d. STAMP.

R. J. SMITH &amp; SON

81 Redbreast Road, Bournemouth

## FREE 10 USED ELIZABETHS FREE

These 10 Beautiful USED COLONIAL stamps will be sent to ALL GENUINE applicants who send 2½d. for postage and ask to see my "WORTH WHILE" approvals.

No stamps sent abroad.

JOS. H. GAZE, 10 Pimlico Road, CLITHEROE, Lancs.



## FREE TO ALL

COLLECTORS  
 6 STAMPS FROM  
 GOLD COAST

send 2½d. postage

BARGAIN 50 CHINA 1/3  
 C.O.D. extra

50 JAPAN 1/3 50 SPAIN 1/-  
 25 EGYPT 1/3 25 PERSIA 1/6  
 100 B. Cols. 2/- 500 All diff. 4/9  
 200 B. Cols. 4/9 1000 All diff. 10/-

G. P. KEEF — WILLINGDON — EASTBOURNE

For other Stamp Advertisements see also pages 592 and 593

## 100 Different Stamps FREE!!

Request 1d. upwards discount Approvals. British Colonials or Foreign. Wants lists welcomed. Don't delay—write today, enclose 2½d. stamp for postage.

C. T. BUSH (MM),

53 Newlyn Way, Parkstone, Poole, DORSET

## PACKET OF QUEEN STAMPS FREE

This Packet, containing many of the latest issues, will be sent FREE to all asking for a selection of stamps on approval. Please enclose 2½d. stamp for postage to you, and address your application to:

G. E. MOAT (Dept. 11),

514 Fairfax Drive, Westcliff, Essex

## OLYMPICS



"OLYMPICS" PACKET containing all the above wonderful stamps with 10 other fine issues ABSOLUTELY FREE. Just send 2½d. postage and ask to see SPECIAL "MERCURY APPROVALS."

PHILIP J. DYKE, 35 BUCKLEIGH AVE., LONDON S.W.20

## FREE!

PICNIC PARCEL

with Approvals 2½d. stamp please.

ALLCOCK, 74 Tynyparc Rd., Rhiwbina, CARDIFF

## FREE! 10 MINT Q.E. II

(Without approvals 1/3 P.O.)

A fine packet of recently issued MINT QUEEN ELIZABETH II stamps will be given to all applicants for my 6d. in 1/- DISCOUNT BRITISH COLONIAL APPROVALS. These books contain many QEII stamps at a cheap price and are well worth your attention. Postage is paid one way.

M. THEOBALD (62)

6 Dell Corner, West Drayton, Middlesex

SPECIAL TO ALL APPROVAL APPLICANTS THIS MONTH. FREE! 1940 Niue Tropical Landscape Mint. 2½d. Postage. A. CUNNINGHAM (Dept. MM), 36 DOONFORT ROAD, AYR

## UNSORTED MIXTURE

1/- ON PAPER. Good Variety. Plenty of Picts. 5/-  
 1/- per Pkt. Large Bags 2/6, 5/-, post extra  
 MARTIN'S STAMP CIRCLE (MM)

13 Lupton Cres., Sheffield 8. Shop: 346 Abbeydale Rd.

FREE—STAMPS CATALOGUED 5/-

to applicants for 1d. approvals, COX, 17 STONELEIGH PARK ROAD, EWELL

# Stamp Gossip

## ST. EDWARD'S WATERMARK

17th July last saw the release of all our British stamps with the St. Edward's Crown watermark. The last value to be changed, on that day, was the 3d. value, so by now it should be possible to obtain in used form a complete set to 1/6.

Some stamps with the old watermark, the Tudor Crown, will still be floating about, for it takes time for old stocks to be cleared out entirely. Remember, the haste should be, not to get the new stamps, but the old ones, for though there are plenty about just now, British stamps have a habit of disappearing quickly.

## SEYCHELLES

This colony has been in the news lately, through the Archbishop of Cyprus being sent there in banishment, and also because of political trouble. All this has drawn attention to its postage stamps, which have always been fairly popular.

Three new values appeared on 15th September, the 10c., 35c. and 70c., replacing three other stamps—9c., 18c. and 45c. values. Now I would like you to get these three latter stamps, for I have a feeling that they will turn out quite good, particularly the 9c. stamp. This was off sale some time at the Crown Agents in London, the agency that supplies dealers with current colonial stamps, and instead of a new printing, a supply was brought back from Seychelles to fill home orders. I don't think that supply was large.

The same kind of thing happened with the 1938 set.

In 1941 several values were changed, and now it costs several pounds to get the original stamps. Don't think for a minute that the stamps just replaced will ever make such big prices as all that. But, to use a favourite collectors' expression, they look like being good in time. This then is my monthly tip.

## THE ZOO

I was recently asked to look at what a young collector called his

Zoo collection. It consisted of a number of stamps all of which had birds, animals and reptiles in their designs. While the mounting could have been improved, taking it all round the gathering did its owner proud—and what a lot of fun he told me he had!

The current set of South Africa, which is so easy and



cheap to obtain, even up to the 10/- value, figured largely in the collection, and what the young enthusiast had done was to go to the local reference library, look out all the Latin names of the creatures shown, and print these neatly under each stamp.

It is not so long since another collector asked me how he could get details of these kind of stamps. And there must be others who would also like an answer to that question. What is needed is a Gibbons Simplified catalogue, which is the finest work of its kind in the world, for practically all stamps are illustrated.

A current copy might be beyond the means of a young collector. If so he should go to a dealer and ask him if he has one a year or two old, not above three years at the outside. If he has, he will only charge a few shillings for it, and then it will be an easy matter to get on with the job. Just look at that chimpanzee on the French stamp illustrated, and there are others as good.

## INDIA

A rather imposing commemorative stamp was issued by India on 23rd July. Mr. E. R. Kooka kindly sent examples and an attractive first day cover. It honours Lokmanya Tilak, who is known as one of the pillars of India's Congress Party, which fought so hard for independence, and also, as I saw described in a book, as the founder of modern India. No wonder that a stamp has been released to commemorate the centenary of his birth.

## CACTUS

It is well known how popular stamps picturing flowers and plants are, and one recently issued by Argentina that is illustrated will be much sought after. This stamp, showing cacti towering well above one's head, makes us wonder what those small things really are that we bring up so tenderly. I have seen those big cacti in Argentina. Some are so thick, that it is impossible to put your arms round them, even if you wanted to—and of course you don't, for those big prickles are sticking out on guard. In the regions where they grow, in such countries as Argentina, Mexico, the United States, etc., they sometimes never get any water for months on end, but they flourish just the same.

## WATERMARKS

Recently a Yorkshire collector sent me an Australian 3½d. stamp, the one with the Queen's portrait, and asked if he had found a scarce variety, he could find no trace of a watermark on his specimen.

All Australian stamps used to have a watermark. Then it was decided to use paper without the watermark for stamps under a face value of 3½d. Next it was announced that all stamps up to a face value of 2/6 would be on plain paper, and already the 3½d. and 2/- stamps have come out thus. This means that the 3½d. value can be found, as can the 2/- value and others as time goes on, with or without watermark.



**A New Era**—(Continued from page 549)

Nagasaki in 1945. A vastly greater source of power is suggested by the success of the hydrogen bomb, which is of the fusion type, its energy being released when the nuclei of deuterium, the heavy form of hydrogen, react to form helium. If this action can yield a bomb of enormous power, it may be possible to tame it so that it can yield power for peaceful purposes. If this can be done power supplies for industrial purposes will be assured to us for a very long time indeed, and there seems no reason to consider it impossible.

All this of course makes 17th October 1956 an even more outstanding date in the history of mankind than I have already suggested, for it can be taken as the beginning of a new era. Without power civilisation cannot make progress, and that day was the first on which the practical application of nuclear energy on a large scale definitely began.

**New Zealand's Rail-Air Service**—(Contd. from page 551)

those 50 railway wagons mentioned earlier.

Three shipping companies had already been asked to quote a price for ferrying the wagons across the Cook Strait and each had suggested a total of £2,540 for the job. As the Freighters were sometimes flying empty or with very small loads on northbound trips at that time, N.Z.R. decided it would be cheaper to fly the wagons from Woodbourne to Paraparau. This was done; history was made; and everyone was happy except, apparently, the shipping companies!

**A Liverpool Landmark**—(Continued from page 556)

vehicles and perhaps one of the few surviving steam wagons—and an aeroplane overhead is by no means unusual.

Our cover this month, based on a colour transparency by W. S. Garth, Tyldesley, shows a train arriving at James Street Station, and on the left in it can be seen the backs of two of the group of buildings on Liverpool's Pier Head that are familiar to the world over. The most prominent structure, light in colour, is one of the ventilation buildings of the Mersey Tunnel, to the left of which is the Mersey Docks and Harbour Board Building, not seen on the cover. Beyond the Tunnel ventilation buildings are the back of the Cunard Building, headquarters of the Cunard Line, and the towering structure of the Liver Building, with a Liver Bird crowning the rear of its two towers.

Soon the line may cease to run, and may even be demolished, for there is a crisis in its affairs. It will be a sorry day if the thrilling run along the Overhead, with its unique views of shipping in the docks or out in the Mersey, can no longer be enjoyed.

**A Joyous Occasion**—(Continued from page 561)

The first train of the day was timed to reach our county town far too late to help workers and school children; the last train home would leave hours too early. The villagers were angry. There were rumours that tomatoes and eggs might be thrown at our train. But the people of this neighbourhood are a law abiding folk. As the train gathered speed and charged through the first station, we were met by cheers, waves, and the cocking of an odd snook or two.

At our first port of call more than a hundred people had assembled beneath the oil lamps on the ancient platform. Lusty cheers rang out and confetti was showered upon the passengers. So it went on all along the line. At one station there was bunting across the platform. At another a great band of cheering well-wishers. And as the train rumbled past the dairy and the timber mills, all work ceased as men and maidens ran out to wave a greeting.

Suddenly the green meadows and woods gave way to red roofs and tall chimneys. We had arrived at journey's end. Ten minutes later, having crossed the bridge to the opposite platform, we were back in the neat compartments with their photographs of Winchester, Southampton and Rye. The shrill whistles of the Mogul locomotive were echoed by the schoolboys standing in the corridor. The guard gravely strode down the train offering tickets to newcomers. Soon the prize Herefords and the Jersey heifers again were stampeding across the fields. Small crowds were cheering again at each of the little stations we had seen less than an hour before.

"What we must all realise," said a determined voice, as I left the train at my home station, "is that this is only the beginning of a new beginning. We must have a public enquiry."

A minute later as the train rattled out of sight, I glanced back at the almost deserted station. A boy was hanging up a gaily coloured poster. "Be Early!" it warned. "Be Early?" The advice is worth noting. For those who miss a train at our local station have some two hours to wait before another one appears, and seventeen hours to wait if they miss the 4.55 p.m.

**Highlights of Farnborough**—(Continued from page 557)

the Twin Pioneer in Swissair colours, symbolising the value of this 16-passenger short take-off aircraft for services in mountainous regions.

Other highlights of the flying programme included a steep climb by a Lincoln test bed on the power of its single nose-mounted Rolls-Royce Tyne turboprop, with the propellers of its four piston engines stopped; a rocket-assisted take-off by a Valiant bomber with two Super Sprite rocket-engines in jettisonable pods under its wings; a 1,350 ft./min. vertical climb and plummeting 3,500 ft./min. descent by the Fairey Ultra-Light helicopter which took off from and landed on a lorry; and the demonstration on a Hunter of a new Rolls-Royce device for diverting the thrust of a jet engine forward after landing, as a method of braking similar to the reversible-pitch propellers of a propeller-driven aircraft.

Add on the engines and equipment displayed on over 330 stands in the "big top" and the result well maintained Farnborough's reputation as the greatest show on earth.

## THIS MONTH'S ARTICLES

	Page
A New Era .. .. .	548
by the Editor .. .. .	
New Zealand's Rail-Air Service .. .. .	550
by John W. R. Taylor .. .. .	
A Liverpool Landmark .. .. .	554
Highlights of Farnborough, 1956 .. .. .	557
by John W. R. Taylor .. .. .	
A Joyous Occasion .. .. .	560
by Garth Christian .. .. .	
Olympic Games City .. .. .	566
by W. H. Owens .. .. .	
Blue Tits in Action .. .. .	578
by John Warham .. .. .	
Air News, 562. Club and Branch News, 591.	
Fireside Fun, 597. From Our Readers, 577. Hornby	
Railway Company pages, 586-590. Junior Section	
pages, 569-576. Meccano Competition, 581. Among	
the Model-Builders, 582. Model of the Month, 584.	
Railway Notes, 564. Road and Track, 552. Shipping	
Notes, 558. Stamp Collecting pages, 593, 595.	

# Fireside Fun

A flustered sparrow was explaining his loss of feathers to a friend.

"I was feeling great," he said, "so I did a few nose dives and some loops and then I decided to do a little hedge-hopping. That's when I got mixed up in a fierce badminton game!"

Canvasser: "You pay a small deposit, then you make no payment for six months."

Lady of the house, suspiciously: "Who told you about us?"

Advertisement in a London restaurant:  
"Our lamb chops are so tender we wonder how the animal ever held together."

A barber arrived at the shop very late and his employer asked him what he had been doing.

"Well, as a matter of fact, I was shaving myself and all of a sudden I talked myself into having a haircut and a shampoo."

A watch repairer looked at the collection of tiny wheels and springs a customer had deposited on his counter, and said, "Are you sure this was once your wrist watch?"

"Oh, yes," the customer assured him. "I suppose I never should have dropped it."

"Well, perhaps you couldn't help dropping it," said the expert, "but why did you bother picking the thing up?"

## BRAIN TEASERS

### THE DIVIDED FIELD

A farmer had a square field, but falling on hard times he had to sell a quarter of it. The piece he sold is shown shaded in the sketch herewith.

When the farmer died his four sons divided the remainder of the field between them, receiving pieces of land of equal size and the same shape. How did they split up the field?

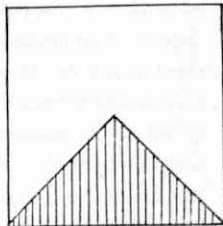

### A LETTER SERIES

Study the following series of seven letters carefully and then see if you can find the meaning of the series and fill in the two blanks with letters of like kind.

O T T F F --

(A. Dobson)

Reproduced by courtesy of the Editor of "Hawker Siddeley Review."

Youngster (back from school): "Ma, I learned to write today."

Mother: "What have you learned to write, Son?"

Youngster: "Don't know yet. Ain't learnt to read."

Policeman: "Why are you driving down the wrong side of the street?"

Young Lady: "I am practising for a Continental holiday!"

Jack: "Hello, Bert, you look glum!"

Bert: "Aye—buried me old dog this morning!"

Jack: "Sorry to hear that—what was the matter with him?"

Bert: "Dead, o'course."

A man went to see his doctor about a pain in his back. The doctor gave him the once-over and in a second the pain vanished.

"That's quick work, doctor," said the patient, "was it rheumatism?"

"No," was the reply, "your braces were twisted."

## ANSWERS TO LAST MONTH'S PUZZLES

### Not Out!

The answer to this cricket problem is batsman No. 8, whose wicket would still be standing when the other 10 had fallen. If you didn't get the correct answer try to work it out now you know the solution. Here's a tip to help you—Don't forget the overs!

### Five Minute Crossword

The solution to the Five Minute Crossword is shown here.

1	M	2	R	3	B	4	E
5	D	O	C	T	O	R	
	6	M	A	R	T		
	7	E	M	I	T		
10	T	O	P	P	L	E	
11	I	S			E	G	

## SPEED ON WHEELS No. 6

When war broke out in 1939 the Land Speed Record of 369.75 m.p.h. was held by John Cobb. In 1947 Cobb returned to America to achieve new honour in the realm of speed. His car was renamed the Railton-Mobil-Special though its design was hardly altered from the pre-war model. The Dunlop tyres, although 30% lighter, were 30% stronger than those used ten years previously. They were tested under the same load they would get from the car, at speeds up to 420 m.p.h. After minor set-backs, Cobb made his historic drive. With an immense effort he pushed the speed up and up. At several points the great car exceeded 400 m.p.h. and his average speed of 394.196 far exceeded anything previously achieved. Cobb's record, which stands to this day, was a triumph for driver, designer and all concerned.

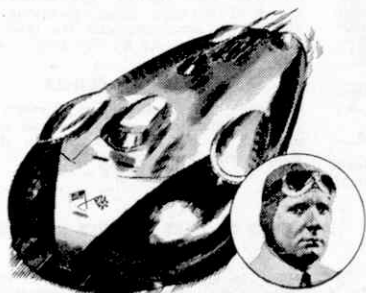

# DUNLOP

## TYRES

Write for a FREE copy of "The Racing World", a fascinating illustrated book on the world's great racing circuits to:

DUNLOP RUBBER CO. LTD. (ADVERTISING DEPT. M6),  
FORT DUNLOP, BIRMINGHAM, 24.

6H/124



is to enrol for one of our

## SIMPLIFIED POSTAL COURSES

Write now for FREE PROSPECTUS

**SHORTHAND** (16 Easy Lessons)  
**TYPEWRITING**

(New Whole Sentence Method)

**BOOK-KEEPING** (The Practical Approach)  
**SECRETARIAL TRAINING**  
**LANGUAGES** (Modern Methods)

Individual Preparation for the following:

**GENERAL CERTIFICATE OF EDUCATION,**  
**CIVIL SERVICE, LOCAL GOVERNMENT,**  
**COMMERCIAL SUBJECTS.**

**TECHNICAL SUBJECTS:** A complete range from  
**CIVIL ENGINEERING to WOODWORK DRAWING**

**Short Story Writing—Writing for Radio & T.V.**

Also Simplified Postal Courses for children for  
**GRAMMAR SCHOOL ENTRANCE**  
**EXAMINATIONS**

Mention the subjects in which you are interested  
and age of child (if applicable) to

The Registrar

## MERCER'S CORRESPONDENCE COLLEGE

(Dept. FF.8.), 69 Wimpole Street, London W.1

## 1956-7 CATALOGUE NOW READY

contains

**MODEL AIRCRAFT, CAR KITS, BOAT**  
**KITS, '00' GAUGE RAILWAY ACCESSORIES,**  
**BILTEEZI SHEETS, MARQUETRY, OIL**  
**PAINTING AND A HOST OF HANDICRAFTS.**

A Bumper issue, well illustrated.  
Send 1/6 for your copy by return.

**Conways** (LEATHERCRAFTS)  
LTD.

P.O. BOX 53, BRADFORD.

Branch at 52 THE HEADROW, LEEDS 1.

### BOOKS:

"00" Gauge Min. Railways Handbook and Guide	2/-
Diesel Locomotives .. .. .	2/6
I Drove Cheltenham Flyer .. .. .	8/6

### RAILWAY ACCESSORIES:

	00	0
Bilteezi Factory Card .. .. .	1/10	—
S/Line Level Crossings .. .. .	6/6	7/-
D/Line Level Crossings .. .. .	11/6	—
Square Water Tanks .. .. .	4/11	—
Scale Cattle Pens .. .. .	6/9	—
5 in. Metal Bridge Girders .. .. .	3/3	3/3
9½ in. Bridge Girders with Handrails	5/11	5/11
Loco. Turntables, State Track required	24/-	—
S/hand "0" Gauge Locos, State requirements,		

Postage extra. New "00" or "0" Parts List 6d. per post.

**TYLDESLEY & HOLBROOK (M.E.T.A.)**  
109 DEANSGATE, MANCHESTER 3

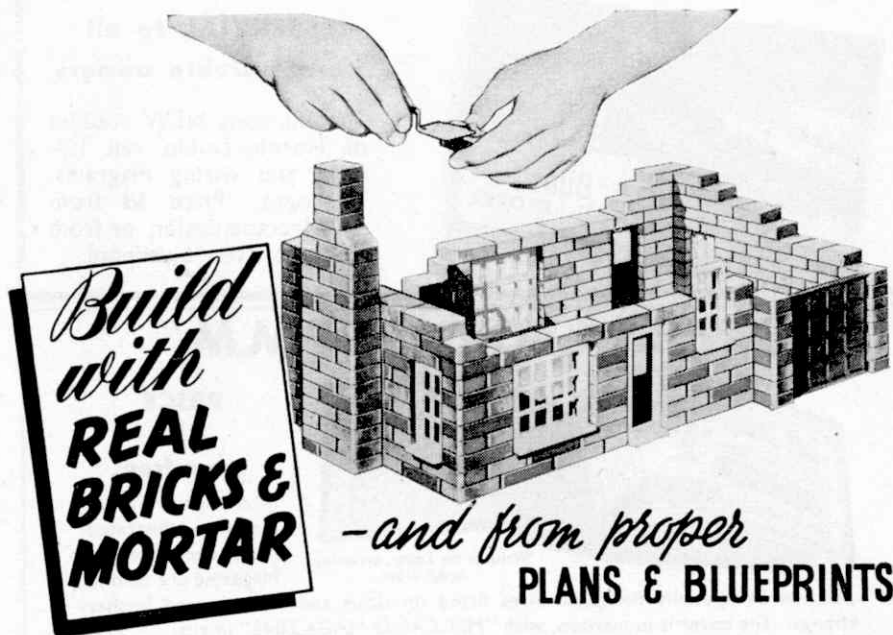

Brickplayer Kit 3 .. ..	26s. 0d.
Brickplayer Kit 4 .. ..	48s. 9d.
Kit 3A converting Kit 3 into Kit 4 .. ..	26s. 0d.
Brickplayer Farm Kit ..	58s. 3d.
2,000 Bricks Box .. ..	55s. 0d.

Extra Bricks, Roofing and Cement in low-priced packs. Windows and Doors obtainable singly.

Brickplayer is more than just a toy—the kits contain *real* building materials—miniature bricks of all required shapes, mortar, roofing, plastic windows and doors, plans and instruction booklet. Furthermore, all models have been designed by an architect to '0' gauge scale. Once completed the buildings will remain permanent or they can be dismantled by merely soaking them in water so that the bricks can be used again.

Do you know that you can win prizes of £21, £10 10s. and £5 5s. and a number of consolation prizes in the grand BRICKPLAYER Contest.

# BRICKPLAYER

The only *real* Building Kit

Obtainable from good toyshops and departmental stores. If your dealer cannot supply, write for address of nearest stockist to:

**J. W. SPEAR & SONS LTD. (Dept. M.) ENFIELD, MIDDLESEX**



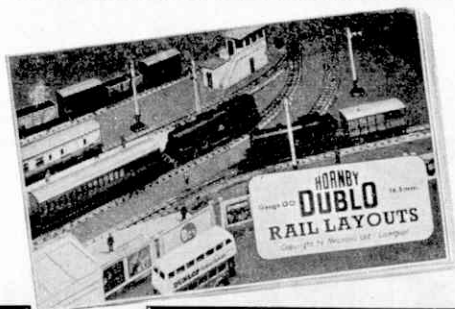

## ESSENTIAL to all Hornby-Dublo owners

A completely NEW booklet of Hornby-Dublo rail layouts, and wiring diagrams. 16 pages. Price 3d from any Meccano dealer, or from Meccano Ltd., Liverpool.

## BINDERS FOR THE "M.M."

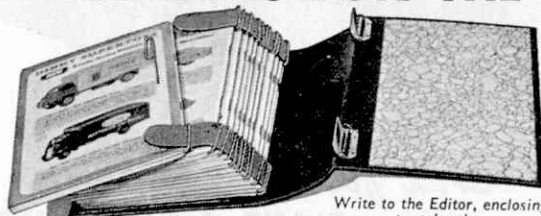

Write to the Editor, enclosing postal order.

position by specially designed wires fitted on stout and well secured leather thongs. The cover is in maroon, with "MECCANO MAGAZINE" in gilt.

PRICE  
8/6

(post free)

In this new type of binder, illustrated here, copies of the Magazine are held in

## A Power-Driven MOTOR CRUISER COMPLETE FOR ONLY

9<sup>d</sup>

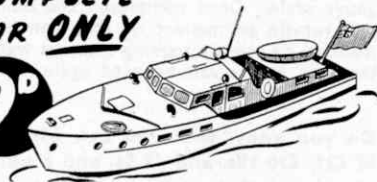

This model builds into a realistic motor cruiser by Thornycroft from three printed cards (in colour) supplied in wrapper with easy-to-follow instructions. A few drops of methylated spirit (unlit) are sufficient to drive the model for 30 minutes or more. This is a fascinatingly simple yet effective model to build that will give hours of pleasure. Easy to build. If ordered by post, add 3d. for postage.

### SPECIAL OFFER

If two cruisers are ordered (total price including postage 1/9) a free Skylon Micromodel will also be sent.

**MODEL-CRAFT**

77 (H) Grosvenor Rd., London S.W.1

## RAILWAY ACCESSORIES

### '00' Scale—Hand Finished

WATCHMAN'S HUT with FIRE and MAN	..	3/-
COAL BUNKER with SCALES and MAN	..	4/-
STATION LAMPS (set of 3)	..	2/-
MILK CHURNS (set of 12)	..	1/6
PLATFORM ACCESSORIES (set of 7)	..	2/6
ALL BILTEEZIE CUT-OUT MODELS	..	1/10
CABLE LAYING PARTY (5 pieces)	..	3/-
WOODSIDE GOODS DEPOT	..	26/6
WOODSIDE SIGNAL CABIN	..	13/9

Send 3/3 for sample box of models and latest illustrated list of many other models, Wrenn Track, etc. Lists only 1/3.

### HANNANT'S

56 LONDON ROAD NORTH, LOWESTOFT, SUFFOLK

**NOW THE MODEL RAILWAY SEASON HAS STARTED ASK YOUR DEALER TO SHOW YOU THE RANGE OF "00" ACCESSORIES WE MANUFACTURE.**

**GOODS YARD CRANE.** A real scale working model enabling you to load and unload your wagons. 9/11. Postage 5d.

The first of a new and unusual series of loads are now available.

Do not forget to get a "DERMIC" Oiler. Keep all your models properly lubricated. 5/6. Postage 3d.

Price List of all our Productions - 6d.

**S. & B. PRODUCTIONS**  
Portland Road, S. Norwood, London S.E.25

Can you identify this Jet Aircraft of

# R.A.F. TRANSPORT COMMAND?



These powerful aircraft cover vast distances at sustained high speeds. You could be a skilled technician servicing these and other modern aircraft—if you join the Royal Air Force as an Apprentice (age 15-17). Pay rates during training have *nearly doubled* under the new R.A.F. scale. For details of an exciting career with a fine future—post the coupon *now!*

*Capacity payload 13,000 lb. Normal stage lengths over 2,200 miles. The de Havilland Comet C.2 cruises at 480 mph at 35,000 to 40,000 ft.*

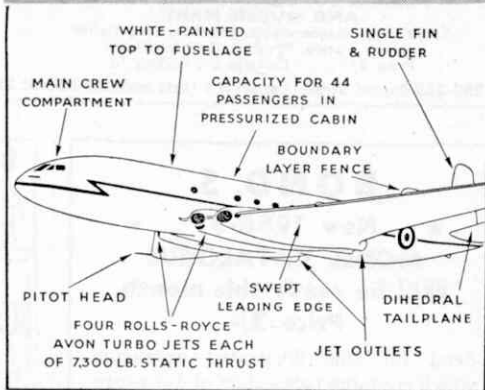

There's a career for you in the

# R.A.F

**send  
for  
details  
now!**

TO: ROYAL AIR FORCE (J.L. 252), VICTORY HOUSE, LONDON, W.G.2.  
*I am over 14. Please send me details of entry for:*

(A) *The Apprenticeship Scheme.*

(B) *The A.T.C.*

*(Tick which you require)*

NAME .....

ADDRESS .....

DATE OF BIRTH .....

*(applicants from British Isles only)*

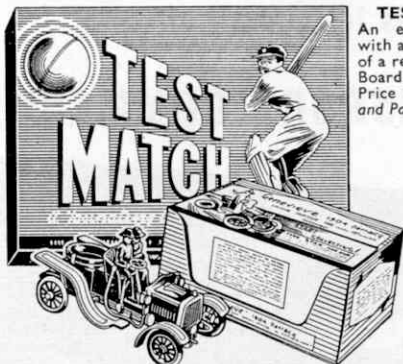

**TEST MATCH**  
An exciting game, with all the suspense of a real Test Match! Board, 15 in. x 11½ in. Price 15/- Carriage and Packing 1/6

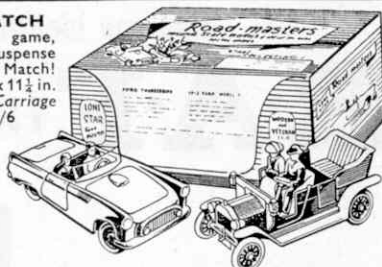

**FORD "THUNDERBIRD" and the 1912 FORD MODEL T.** Accurate scale models in full detail of the past and the present. Price 9/11 Carriage and Packing 1/-

**"GENEVIEVE" 1904 DARRACQ**  
This intriguing model of a famous vintage car helps create the thrill of the annual Brighton Run. Price 5/11 Carriage and Packing 9d.

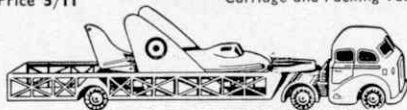

**"PUSH & GO" MECHANICAL HORSE AND QUEEN MARY**

Surprisingly manoeuvrable, the 7 in. long trailer carries a scale, "Push & Go" Jet Plane. Price 5/- Carriage and Packing 7d.

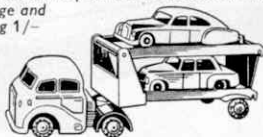

**"PUSH & GO" MECHANICAL HORSE AND CAR TRANSPORTER**

A sturdy vehicle, carrying two perfect scale models. Price 5/- Carriage and Packing 7d.

200-202 Regent Street, London W.1 (only address) REgent 3161

**Hamley's**  
ESTD 1766  
HAMLEY BROTHERS LTD  
The Finest Toyshop in the World

## BOND'S

\* New 1956-57 \*  
**MODEL CATALOGUE**  
Will be ready this month  
Price 2/-

Send for this illustrated catalogue which contains particulars of our range of Model Railway Parts from "00" gauge to 3½ in. gauge steam locomotive parts.

Model Ships and Ship Fittings.  
Model Aeroplanes and parts.  
Stationary Steam Engines, etc.

We can also supply a Light Engineering Catalogue which lists our range of Materials, Tools, Gears, Steam Fittings and Electric Motors, etc. Price 1/9.

**BOND'S O' EUSTON ROAD LTD.**  
357 EUSTON ROAD, LONDON N.W.1  
Est. 1887 'Phone: EUSTon 5441-2

## CHEMISTRY APPARATUS

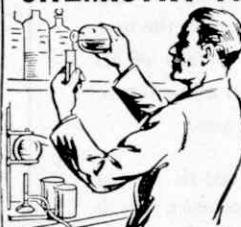

Send 2½d. Stamp  
for latest  
**PRICE LIST**

BOOKLETS:  
"Experiments" 10½d.  
"Formulas" 10½d.  
"Home Chemistry" 2/3  
Post Paid

**BECK** (Scientific Dept. G), 60 High Street  
STOKE NEWINGTON, LONDON N.16

## HEAR ALL CONTINENTS

WITH H.A.C. SHORT-WAVE RECEIVERS

Noted for over 18 years for . . .  
S.W. Receivers and Kits of Quality.

Improved designs with Denco coils:  
One-Valve Kit, Model "C" . . . . . Price 25/-  
Two-Valve Kit, Model "E" . . . . . Price 50/-

All kits complete with all components, accessories, and full instructions. Before ordering call and inspect a demonstration receiver, or send stamped, addressed envelope for descriptive catalogue.

"H.A.C." SHORT-WAVE PRODUCTS  
(Dept. M.M.), 11 Old Bond Street, London W.1



# IT'S FAR SAFER WITH RAWLPLUGS!

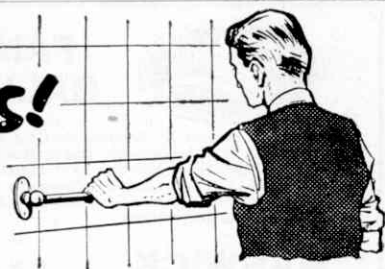

IN SCREW FIXING, Rawlplugs are not only the quickest way, the easiest way, but give you the strongest, safest fixing. No damage to masonry or decorations, paint or wallpaper! Simply Rawltool the hole, slip in a Rawlplug, screw up the fixture. Add a Rawlplug Outfit to your toolkit; it contains Rawlplugs, Rawltool, screws, 16-page 'Hints on Fixing'—all you need! Popular Outfit, 3/-; larger outfits 5/6d. and 10/6d.

## THE WORLD'S SPEEDIEST MASONRY DRILL

When you've a number of holes to drill, try the swift professional way with a Rawlplug DURIUM-tipped Masonry Drill. Cuts clean, accurate holes at amazing speed; can be used in hand brace or suitable electric drill. Refuse imitations—look for the name DURIUM on the shank.

**RAWLPLUG  
DURIUM-TIPPED DRILLS**



B572A

FROM YOUR IRONMONGER OR HARDWARE DEALER

THE RAWLPLUG COMPANY LTD · LONDON · S.W.7

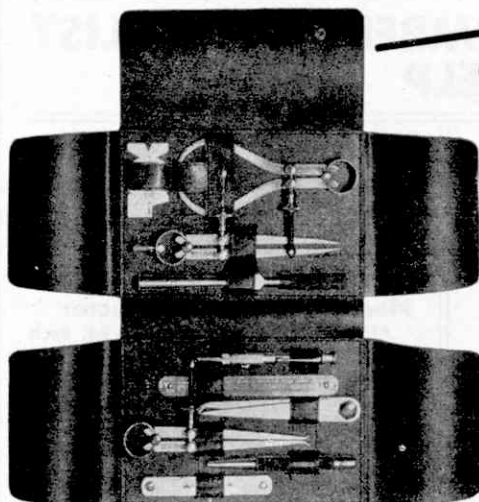

## M&W SETS OF TOOLS

... are made up with the requirements of the Model Maker, Apprentice Engineer, Handyman, etc., in mind. They are supplied in attractive black wallets as illustrated, and there are nine various sets of tools available as well as certain other ranges of our tools in similar wallets. Our catalogue gives full information.

Free copy of our booklet, THE USE AND CARE OF MICROMETERS (which includes 25 pages of Decimal Equivalents), will be sent to you if you will send us your Tool Dealer's receipt indicating your purchase of 20/- or more of M. & W. tools.

Send 8½d. in stamps, mentioning this journal, for a copy of our Catalogue.

**MOORE & WRIGHT (Sheffield) Ltd**  
Norton Lane, Sheffield 8

## FOR THE BEGINNER

If you want to start developing and printing your own photographs and are not quite sure what you need, Johnson Home Photography Outfits provide the answer. Each outfit is a complete self-contained unit including the most up-to-date Johnson equipment and chemicals. A 100-page book of instructions is included with the Developing and Printing sets.

**No. 1 Outfit** contains everything necessary for making prints from  $2\frac{1}{2} \times 2\frac{1}{2}$  in. and  $2\frac{1}{2} \times 3\frac{1}{2}$  in. negatives. Includes Plastic Printing Frame, Portable Darkroom Lamp, Dishes, Measure, Thermometer, Chemicals, etc. Price **£1 17s. 6d.**

**No. 3 Outfit** (as illustrated) for developing 120 and 620 films. Includes a Johnson Developing Tank, Measure, Thermometer, Clips, Chemicals, etc. Price **£2 10s. 0d.**

**No. 21 Outfit** incorporates a Johnson Battery Printer for making first-class  $2\frac{1}{2} \times 2\frac{1}{2}$  in. and  $2\frac{1}{2} \times 3\frac{1}{2}$  in. prints. No mains electricity required. All necessary Chemicals and Equipment are supplied with the outfit. Price **£2 11s. 6d.** Battery extra 2/9.

**No. 22 Outfit** has the Johnson Mains Printer, a Water Circulator for washing prints and everything else required to produce sparkling contact prints. Price **£3 4s. 6d.**

Also available:

**No. 5 Outfit** for Drying and Glazing Prints. **£4 15s. 0d.**

**No. 6 Outfit** for making your own Postcard size Enlargements **£4 12s. 6d.**

**No. 44 Outfit** contains complete Darkroom Equipment and Chemicals **£5 12s. 6d.**

JOHNSONS OF HENDON LTD.

LONDON N.W.4



## JOHNSON PHOTOGRAPHY OUTFITS

# REAL MOVIE SHOWS AT HOME!



ONLY  
**59/6**

COMPLETE  
WITH  
3 FILMS

**Wonderful Home Entertainment!**

THE ONLY 16 mm. PROJECTOR OF ITS KIND. FROM TOY SHOPS, HOBBY SHOPS AND STORES or write for name of nearest stockists to Sole World Distributors:

**J. S. FRIEZE & CO. LTD., 37 Devonshire St., London W.1. Welbeck 2994 (3 lines)**

with the

## NEW PEAK

16 mm. CINE PROJECTOR

Two projectors in one—movie or still. Easy to operate, no technical knowledge required. Battery fits in Base, on/off switch, no outside connections, or from mains through transformer. Replacement bulbs and batteries obtainable anywhere.

NEW! Added control-knob, for steadier pictures at NO EXTRA COST.

A STURDY machine at an AMAZINGLY LOW PRICE. BUILD UP A COMPLETE SHOW.

A comprehensive supply of films featuring:

ZOO, CIRCUS, CHARLIE CHAPLIN, COMEDIES, SPORT, CORONATION, PAGEANTRY, WESTERNS, ETC.

FILM PRICES FROM 1/6 TO 7/6 EACH.

COMPLETELY SAFE.

NON-INFLAMMABLE FILM.



# GAMAGES MAMMOTH MODEL RAILWAY

This illustration shows a small section of the 1955 layout

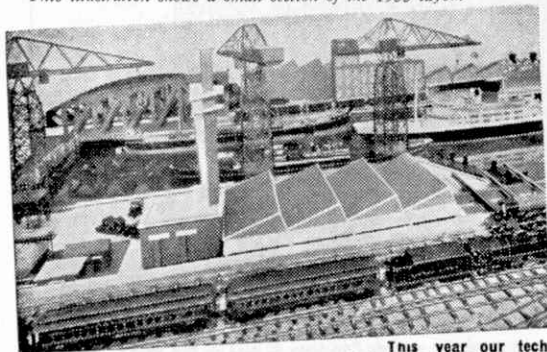

This year our technical experts and display staff have excelled themselves . . . the new layout transcends all previous efforts. It covers an area of approximately 1,000 sq. feet. . .

**THE LARGEST OF ITS KIND IN THE WORLD !!**

The carefully worked out scenic effects include a magnificent miniature park with a bandstand and a real water fountain. There is a mechanical fairground with a giant wheel and brightly coloured roundabout, a helicopter landing station and a mountain feature upon which there are many moving cars. **PACKED WITH LIFE AND MOVEMENT**

**THE WORLD'S MOST FAMOUS  
CHRISTMAS BAZAAR**

GAMAGES, HOLBORN, LONDON E.C.1. HOL. 8484

## FREE MATCHBOX LABEL



This scarce SIAMESE label sent FREE to all those sending 3d. for our MATCHBOX LABEL APPROVALS

## CIGARETTE CARDS

Send 6d. for CATALOGUE of 1,000 different series.

**WE OFFER COMPLETE SETS**

25 Planes 2/- 25 Cars 1/9 25 Butterflies 1/9  
50 Navy 2/6 50 Trains 2/6 50 Animals 2/6

## CHEESE LABELS

50 different 3/-; 100 different 7/-; 200 different 15/-  
25 different Swiss 2/6; 10 diff. Austria/Germany 2/-

E.H.W. Ltd. (Dept. M),

12 SICILIAN AVENUE, LONDON W.C.1

SEND NOW FOR ONE OF THESE

## MODEL RAILWAY TUNNELS

'00' GAUGE - 10 ins. long

**5/3** EACH

Post & Pkg.  
1/3 extra  
or C.O.D.

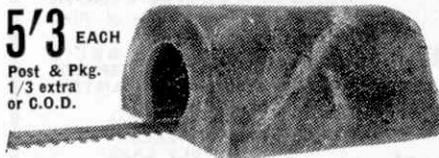

Strongly Constructed Special Realistic Finish

Other '00' Gauge - 10 ins. long - 6/3 } plus 1/3 post  
Sizes: '00' " - 7 " - 4/9 } and packing  
'00' " 10 ins. Doubletrack 6/6 }

**WILFRID MAHOOD LTD., ORMSKIRK, LANCs.**

Gamages 1957 Edition  
132-PAGE, FULLY ILLUSTRATED  
**MODEL & TRAIN  
BOOK**

STILL THE  
SAME  
LOW PRICE

**1/-**

POST 4d.



The previous issues were acclaimed by many to be the most complete reference books on Model Trains, Boats, Cars, Planes, etc., available. This issue includes full particulars and prices of all models and accessories available at Gamages and even more interesting Facts, Figures, and Photographs about Railways, Airways, Liners, Racing Cars, etc.

New 1957 Edition  
**CONJURING CATALOGUE**  
Price 1/- Post 4d.

## REALISM IN MODELLING

Cardboard is not a makeshift material with which to work; suitable card correctly treated gives great strength, long life and perfect detail. These qualities make it the ideal material for the building of goods vehicles and no modeller can afford to be without our famous textbook "CARDBOARD ROLLING STOCK AND HOW TO BUILD IT", Price 3/6 (by post 3/9). The 45 pages of clear instructions, diagrams and photographs show how easily a perfect and fully detailed wagon or van can be built. For details of ERG "Precision" Card Parts and the fine range of 00 fittings and accessories available to all railway modellers see: THE ERG CATALOGUE, Price 1/6 (by post 1/9). Also "CARDBOARD PASSENGER STOCK AND HOW TO BUILD IT", Price 6d. (by post 8d.). For every railway modeller's library, "A STUDY OF THE MODEL RAILWAY", Price 3/6 (by post 3/9). The fascinating textbook that gives a new insight into the hobby, The ERG Modeller's Scaled Rule, Price 2/10 (postage and packing 4d.).

**ERG (Bournemouth) LTD**

529 Roumelia Lane, Boscombe, Bournemouth

ACCURATE  
HARDHITTING

**Webley**



**AIR PISTOLS**

**AIR RIFLES · ACCESSORIES**

Write for catalogue **WEBLEY & SCOTT Ltd.**  
87 WEAMAN ST., BIRMINGHAM 4, ENGLAND

get  
your**Jan Allan**  
**BOOKS**from  
**LOCOMOTIVE PUBLICATIONS**  
32 RAILWAY APPROACH  
LONDON BRIDGE, S.E.1**Trains Annual**

CECIL J. ALLEN .. .. 10/6

**Aircraft Annual**

JOHN W. R. TAYLOR .. .. 10/6

**Ships Annual**

CRAIG J. M. CARTER .. .. 10/6

**Motoring Annual**

DOUGLAS ARMSTRONG .. 10/6

**Locospotters' Annual**

G. FREEMAN ALLEN .. .. 6/-

**aircraft books**

- abc CIVIL AIRCRAFT MKGS. 2/6  
 abc CIVIL AIRCRAFT REGGN. 2/6  
 abc MILITARY AIRCRAFT 3/-  
 abc U.S. & CANADIAN  
 MILITARY AIRCRAFT 3/6  
 abc CONTINENTAL  
 MILITARY AIRCRAFT 3/-  
 abc HELICOPTERS .. .. 2/6  
 abc ROCKETS & SPACE  
 TRAVEL .. .. 3/-

**motor books**

- abc BRITISH CARS .. 2/6  
 abc AMERICAN CARS .. 2/6  
 abc CONTINENTAL CARS 2/6  
 abc SPORTS CARS .. 2/6  
 abc BUSES & COACHES 2/6  
 abc LORRIES & B.R.S. 2/6  
 abc L.T. BUSES .. 2/6  
 abc RIBBLE BUSES .. 2/6  
 abc BUS FLEETS S.E.  
 AREA .. .. 2/6

**NEW 1957 Editions**  
**NOW READY****abc B.R. Locomotives**

- 1: WESTERN REGION 2/6  
 2: SOUTHERN REGION 2/6  
 3: LONDON MIDLAND 2/6  
 4: EASTERN REGION 2/6
- COMBINED  
VOLUME  
10/6

**ship books**

- abc OCEAN LINERS .. .. 2/6  
 abc OCEAN TANKERS .. .. 2/6  
 abc OCEAN FREIGHTERS .. .. 2/6  
 abc BRITISH TUGS .. .. 2/6  
 abc COASTAL PASSENGER SHIPS .. 2/6  
 abc COASTAL CARGO SHIPS .. 2/6

abc  
**WARSHIPS**  
1956  
EDITION  
2/6

**STOP!**

**GET YOUR  
RAILWAY  
MODELLER  
SHOW NUMBER  
NOW!**

This Special Enlarged November issue to celebrate the Model Railway Hobby Show is an ABSOLUTE MUST! If you are at all interested in Model Railways you cannot afford to be without this number.

ON SALE AT THE EXHIBITION  
OR FROM ALL GOOD MODEL-  
SHOPS AND NEWSAGENTS

1/6 MONTHLY

1/8 post paid.

RAILWAY MODELLER  
PECOWAY : STATION ROAD  
SEATON : DEVON

**STICK  
TO****-it sticks  
everything!**

PER TUBE

*Keep a tube  
in the home*

Sole Manufacturers :  
McCaw, Stevenson & Orr Ltd., Belfast

**FOR GIFT TIME****AVAILABLE FREE!**

YOUR OWN CATALOGUE of books by favourite authors and artists. Books for all the family and your friends.

Write to the address below for

**"BOOKS MAKE IDEAL GIFTS"**

a fully descriptive and illustrated booklet which will make your choice of presents easy.

**FREDERICK WARNE & Co. Ltd.**  
1-4 Bedford Court, London W.C.2

**G.C.E**

Wolsey Hall (est. 1894) can prepare you **successfully** by post for all G.C.E. examinations; Lond. Univ. Degrees and many other exams. Moderate fees, instalments. 27,000 successes since 1930. Prospectus from C. D. PARKER, M.A., LL.D., Dept. GK5, **WOLSEY HALL, OXFORD**

Call and see our selection of model aircraft kits and accessories, model railways and constructional sets. Everything for the model maker.

**WILMSLOW MODEL CO.,**

Water Lane, Wilmslow, Cheshire.

**Crystal Set Kits 15/8**

With permanent detector. Loud and clear reception. No batteries required. Ideal for School or College. Lightweight Headphones 16/4. All post free.

W. J. BUCKLE 77 Horringer Rd., Bury St. Edmunds

**READERS' SALES AND WANTS****SALES**

"M.M.s" October 1944-December 1950. "Aeromodellers" March 1946, June-September 1947, June 1948-May 1950. "Buses Illustrated" Nos. 1-13. Offers—J. Duffy, 14 Rycroft Road, London S.W.16. 50/- Kodak Pocket Camera f8, perfect.—Burns, 6 Niddrie Road, Portobello, Scotland. "M.M.s" 1950-June 1953. What offers?—Hunter, 140 Swarkestone Road, Chellaston, Derby. "M.M.s" 1950 to June 1956 (January, May 1950 missing), 35/- or offers.—Daly, 7 Granville Park, Lewisham.

£23 worth of Gauge 00 Electric Railway. Almost new. What offers? S.A.E. for list.—D. Garton, 330 Abbey Street, Derby.

"M.M.s" 1933-1940 inclusive also May 1950-August 1956. All in good condition. Offers to—J. Quelch, 219 Windsor Avenue, Hillingdon, Middlesex.

"M.M.s" January 1945-December 1954 inclusive. Ten complete years. Excellent condition. Offers for separate years or complete.—Beeken, 67 Meynell Street, Derby.

Gibbons Catalogues. Empire 1955 9/6d., Europe 1952 6/6d., Part 3 1951 4/6d.—151 Gower Road, Swansea.

"M.M.s" January to May 1939, January 1945 to January 1950. Good condition. Offers? S.A.E. for details.—Johnson, 14 Berrow Park Road, Pevee, Plymouth.

**MECCANO MAGAZINE**

Registered at the G.P.O., London, for transmission by Canadian Magazine Post.

**EDITORIAL AND ADVERTISING OFFICES:**

LIVERPOOL 13, ENGLAND.

Telegrams: "Meccano, Liverpool."

**Readers' Sales and Wants.** Private advertisements (i.e. not trade) are charged 2d. per word, minimum 2/- Cash with order. Readers' advertisements are published as soon as possible; inclusion in the first issue after receiving them cannot be guaranteed.

Advertisements of goods currently manufactured by Meccano Ltd. cannot be accepted.

**WANTS**

Obsolete Military Dinky Toys, all types. Good condition and unbroken, if possible. Send details.—V. Brown, 27 Esplanade Terrace, Joppa, Portobello, Midlothian.

Obsolete Dinky Toys, French Dinkys and similar scale metal models, Trix Rolling Stock and Lineside equipment, Dinky Catalogues, reasonable condition. "Buses Illustrated" No. 8, 'road' Books, unused condition. Details to—G. Harrison, 6 Manor Hall Drive, Hendon, N.W.4.

Obsolete Hornby-Dublo L.N.E.R. Two Coach Articulated Unit.—B. Richardson, Fairhaven, Church Road, Killynely, Co. Dublin, Eire.

Pre-war Dinky and Skybirds Army Personnel required. Please state condition and price. All letters answered.—L. Manwaring, 14 Plover Gardens, Cranham, Essex.

Any pre 1945 Dinky Toys R.A.F. Aircraft. State price and condition.—J. Tunnicliff, 2 Park Street, Leamington, Warwick.

We wish to buy back or otherwise re-acquire, one Hornby Gauge 0 Clockwork 'County' Class, G.W. Locomotive, with Tender, and one L.M.S. Tank 4-4-4 Locomotive. These two Locos. were sold autumn 1949 in good condition. Best possible condition required now.—Watford Model Railway Society, Bank House, Tring, Herts.

**STAMP ADVERTISEMENTS**

(see also pages 592 and 594)

**★ JAMAICA ★**

3 of the latest

Q.E. most

attractive large pictorials to all sending 2½d.

postage for Approvals. (Overseas 1/-)

S. REY (JA), 10 Walsh Avenue, Knowle, BRISTOL 4

**OLYMPIC DIAMOND PKT. 36 FREE!**

MONACO, World Football diamond, SAN MARINO, 2 Winter Olympic Games 1956, Skating and Ski-ing, plus 33 other stamps Free. Send 2½d. postage and request approvals. Rosebery Stamp Service (Dept. A.4), 37 Rosebery Road, Epsom

**10 DIFFERENT Q.E. II CORONATION STAMPS FREE!**

To all Applicants for my G, VI & Q.E. II

Approvals. Enclose 2½d. stamp.

B. R. TOWLER, S.C.A., BCM/MITRE, London W.C.1

**FREE! HUNGARY SCIENTISTS**

To all approval applicants stating their chief interests and enclosing 2½d. postage.

J. D. HARRIS

(Stamp Approval Service), 38 Stroud Road, London S.W.19

**250 FOREIGN STAMPS FREE!** All clients receive the above entirely free when enrolling in our club. Many other packets available as BONUS GIFTS. WRITE

NOW for details and approvals enclosing postage.

PARAGON STAMP CO. (Dept. M),

138 Oakley Road, Shirley, Southampton

# HORNBY TRAINS

BRITISH & GUARANTEED

Gauge 'O'  
Clockwork



HORNBY GOODS TRAIN SET No. 20.—  
Non-reversing locomotive (illustrated above) £1/7/6

HORNBY GOODS TRAIN  
SET No. 30.—Reversing  
locomotive (not illustrated)  
£1/19/0



HORNBY PASSENGER TRAIN SET No. 21.—  
Non-reversing locomotive (illustrated above) £1/7/6

HORNBY PASSENGER  
TRAIN SET No. 31.—  
Reversing locomotive (not  
illustrated).....£1/19/11



HORNBY TANK GOODS TRAIN SET No. 40.  
Reversing locomotive (illustrated above) £2/15/0

HORNBY TANK  
PASSENGER TRAIN SET  
No. 41.—Reversing locomotive  
(not illustrated)...£2/17/6



HORNBY PASSENGER TRAIN SET No. 51.—  
Locomotive reversible from track (illustrated  
above).....£3/12/6

HORNBY GOODS TRAIN  
SET No. 50.—Locomotive  
reversible from track (not  
illustrated).....£3/12/6

All Prices include  
Purchase Tax

Ask your local Meccano dealer for a free copy of  
the Hornby Trains folder in colour or write to  
Meccano Ltd.

MECCANO LTD., BINNS ROAD, LIVERPOOL 13



# DINKY TOYS

TRADE MARK REGISTERED

**New**



**Ready during November**

## **DINKY TOYS No. 715 BRISTOL 173 HELICOPTER**

Helicopters are in the news today, and none more than the Bristol 173. The original of the fine model above is a 14-seater, twin-engined helicopter with two 3-blade main rotors in tandem, and has a range of about 280 miles at a speed of 85 m.p.h. The fuselage of the model measures  $3\frac{3}{8}$  in. in length, and is beautifully enamelled in light blue and red.

**U.K. PRICE 2/11 (inc. Tax)**

**ASK YOUR LOCAL DEALER** for a copy of the Dinky Toys coloured booklet—or write direct to Meccano Ltd.

**MECCANO LTD. • BINNS ROAD • LIVERPOOL 13**

FLOATING CRANE

Illustrated in the November 1956 issue of the "Meccano Magazine

(This model can be built with Outfit No. 8)

Construction of the Pontoon

Each side of the pontoon consists of two  $12\frac{1}{2}$ " x  $2\frac{1}{2}$ " Strip Plates overlapped three holes and edged by two  $12\frac{1}{2}$ " Angle Girders and two  $12\frac{1}{2}$ " Strips, each pair of Girders and Strips being overlapped 14 holes. The ends of the front Strip Plates are curved as shown and are connected at the bow by two Obtuse Angle Brackets. The stern is filled in by two  $4\frac{1}{2}$ " x  $2\frac{1}{2}$ " Flexible Plates, strengthened along their lower edges by two  $4\frac{1}{2}$ " Strips and bolted at each end to a  $2\frac{1}{2}$ " x  $\frac{1}{2}$ " Double Angle Strip 1. The upper lugs of these Double Angle Strips are fixed to the rear ends of the  $12\frac{1}{2}$ " Angle Girders, and the lower lugs are attached to the  $12\frac{1}{2}$ " Strips by Angle Brackets.

The deck is plated by four  $4\frac{1}{2}$ " x  $2\frac{1}{2}$ " Flexible Plates 2, two  $5\frac{1}{2}$ " x  $2\frac{1}{2}$ " Flexible Plates 3, two  $12\frac{1}{2}$ " x  $2\frac{1}{2}$ " Strip Plates 4, a  $5\frac{1}{2}$ " x  $1\frac{1}{2}$ " Flexible Plate 5, a Hinged Flat Plate 6, two Flanged Sector Plates, two  $2\frac{1}{2}$ " x  $2\frac{1}{2}$ " Flexible Plates 7, two  $3\frac{1}{2}$ " x  $1\frac{1}{2}$ " Triangular Flexible Plates 8, and two  $3\frac{1}{2}$ " x 2" Triangular Flexible Plates 9. These Plates are arranged as shown in Fig. 2 and are bolted to the  $12\frac{1}{2}$ " Angle Girders and to Angle Brackets at the stern and the bow. At the bow the Triangular Flexible Plates are edged by a  $2\frac{1}{2}$ " Curved Strip and a  $3\frac{1}{2}$ " Strip on each side. A 1" Triangular Plate is bolted to the overlapped front corners of the Plates 9. A 3" Pulley is bolted to the deck, with its boss projecting through the gap left between the Plates 7.

Two  $3\frac{1}{2}$ " x  $2\frac{1}{2}$ " Flanged Plates are attached to the sides of the pontoon, and to them are fixed further  $3\frac{1}{2}$ " x  $2\frac{1}{2}$ " Flanged Plates 10. These Flanged Plates are connected to the 3" Pulley by 1" x  $\frac{1}{2}$ " Angle Brackets, and a  $2\frac{1}{2}$ " x  $\frac{1}{2}$ " Double Angle Strip is bolted between them by a bolt 11 on each side. A  $3\frac{1}{2}$ " x  $\frac{1}{2}$ " Double Angle Strip 12 is supported by a  $2\frac{1}{2}$ " x  $\frac{1}{2}$ " and a  $2\frac{1}{2}$ " x 1" Double Angle Strip fixed to the Plates 10.

Two  $2\frac{1}{2}$ " x  $1\frac{1}{2}$ " Flanged Plates 13 are attached to the Hinged Flat Plate 6 by Angle Brackets, and are connected at one end by a  $3\frac{1}{2}$ " x  $2\frac{1}{2}$ " Flanged Plate and at the other end by a  $3\frac{1}{2}$ " x  $\frac{1}{2}$ " Double Angle Strip. A  $2\frac{1}{2}$ " x 1" Double Angle Strip 14 is bolted to the Flanged Plate and the Double Angle Strip. Two 1" x 1" Angle Brackets connected by a  $2\frac{1}{2}$ " Strip 15, are attached to the Flanged Plates 13.

The top of the deckhouse is a  $5\frac{1}{2}$ " x  $2\frac{1}{2}$ " Flanged Plate and the walls are  $5\frac{1}{2}$ " x  $1\frac{1}{2}$ " and  $2\frac{1}{2}$ " x  $1\frac{1}{2}$ " Flexible Plates edged by  $5\frac{1}{2}$ " and  $1\frac{1}{2}$ " Strips as shown in Fig. 1. The funnel consists of two Cylinders connected by Fishplates and attached to the Flanged Plate by an Angle Bracket. The ventilators are  $1\frac{1}{8}$ " Flanged Wheels locked by nuts on Screwed Rods. The deck house is attached to the pontoon by Angle Brackets.

A Boiler End is fixed to the deck by a Coupling and a  $\frac{1}{2}$ " Pinion on a  $1\frac{1}{2}$ " Rod.

Assembly of the Tower

The tower consists of four  $12\frac{1}{2}$ " Angle Girders connected at their lower ends by four  $5\frac{1}{2}$ " Angle Girders. A  $5\frac{1}{2}$ " x  $2\frac{1}{2}$ " Flanged Plate 16 (Fig. 3) is bolted between two of the  $5\frac{1}{2}$ " Girders, and a platform



is attached to three of them. This platform is made from three  $5\frac{1}{2}$ " x  $1\frac{1}{2}$ " Flexible Plates and two  $2\frac{1}{2}$ " x  $2\frac{1}{2}$ " Triangular Flexible Plates. The upper ends of the  $12\frac{1}{2}$ " Girders are connected by two  $5\frac{1}{2}$ " x  $1\frac{1}{2}$ " Flexible Plates and four  $5\frac{1}{2}$ " Strips.

A 3" Pulley is attached by two  $\frac{3}{4}$ " Bolts to the Flanged Plate 16 and a 4" Rod is fixed in its boss. The Rod is passed through the 3" Pulley of the pontoon and through the Double Angle Strip 12, and is fitted with a 2" Sprocket. This Sprocket is connected by Chain to a  $\frac{3}{4}$ " Sprocket on a  $3\frac{1}{2}$ " Rod 17, Fig. 8, which is mounted in the Hinged Flat Plate 6, the Strip 15 and the Double Angle Strip 14. A handle on the Rod is provided by a Crank bolted to a Wheel Disc and fitted with a Threaded Pin.

Two  $5\frac{1}{2}$ " Strips 18, and three further  $5\frac{1}{2}$ " Strips 19 and a built-up  $5\frac{1}{2}$ " strip, are bolted to the tower as shown in Fig. 3. The built-up strip consists of a  $4\frac{1}{2}$ " and a 2" Strip.

### The Jib

Each side of the jib is formed by a strip 20 made from two  $12\frac{1}{2}$ " Strips overlapped 15 holes, a  $12\frac{1}{2}$ " Angle Girder 21 extended 11 clear holes by a  $12\frac{1}{2}$ " Strip, three  $5\frac{1}{2}$ " Strips 22 and a  $3\frac{1}{2}$ " Strip 23. The lower ends of Strips 22 are fitted with a  $2\frac{1}{2}$ " x 2" and a  $2\frac{1}{2}$ " x  $1\frac{1}{2}$ " Triangular Flexible Plate, and the side is braced by Strips as shown in Fig. 1.

The sides are connected by two  $5\frac{1}{2}$ " x  $\frac{1}{2}$ " Double Angle Strips 24, two  $2\frac{1}{2}$ " Strips overlapped two holes and fixed to Angle Brackets held by bolts 25, a  $2\frac{1}{2}$ " x  $\frac{1}{2}$ " Double Angle Strip held by bolts 26, and two 1" x 1" Angle Brackets at the jib head. A built-up  $5\frac{1}{2}$ " x  $\frac{1}{2}$ " double angle strip 27 is made from two  $2\frac{1}{2}$ " x  $\frac{1}{2}$ " Double Angle Strips and a  $2\frac{1}{2}$ " Strip, and to it are bolted two Trunnions. A 1" loose Pulley is mounted between the Trunnions on a 2" Rod. A 1" fixed Pulley 28 is fixed on a  $1\frac{1}{2}$ " Rod supported in a Stepped Bent Strip.

A 1" fixed Pulley is mounted on a  $1\frac{1}{2}$ " Rod supported in a Channel Bearing 29, and a further 1" Pulley is fixed on a 2" Rod held in the jib head by Spring Clips.

The jib pivots on a  $6\frac{1}{2}$ " Rod held by Collars in  $1\frac{1}{2}$ " Strips bolted to the tower. It is luffed by turning a Bush Wheel on a  $3\frac{1}{2}$ " Rod 30 mounted in the tower and in a  $4\frac{1}{2}$ " x  $\frac{1}{2}$ " Double Angle Strip 31. The Rod carries at its inner end a  $1\frac{1}{2}$ " Contrate that engages a  $\frac{1}{2}$ " Pinion on an  $11\frac{1}{2}$ " Rod. This Rod is supported in the Flanged Plate 16, in a  $1\frac{1}{2}$ " x  $\frac{1}{2}$ " Double Angle Strip 32, a  $2\frac{1}{2}$ " x  $\frac{1}{2}$ " Double Angle Strip 33 and a  $\frac{1}{2}$ " Reversed Angle Bracket 34. The  $11\frac{1}{2}$ " Rod is fitted at its upper end with a built-up universal coupling, made from a Swivel Bearing and a small Fork Piece connected by two bolts. This coupling joins the  $11\frac{1}{2}$ " Rod to a 3" Screwed Rod threaded through a Coupling 35. The Coupling 35 pivots on two 1" Rods held by Collars in a  $1\frac{1}{2}$ " x  $\frac{1}{2}$ " Double Angle Strip.

The luffing action is guided by 2" Rods sliding through Angle Brackets 36 lock-nutted to Corner Gussets bolted to the tower. Each of the 2" Rods is held in a Coupling 37 screwed on a  $\frac{1}{2}$ " Bolt passed through the side of the jib.

### The Hoisting Mechanism and Cords

Each of the two load hooks is operated by Cord fastened to a winding drum consisting of a Sleeve Piece and two  $\frac{3}{4}$ " Flanged Wheels. These drums are fixed on  $6\frac{1}{2}$ " Rods held in the Strips 18 by Collars, and each Rod

is fitted with a 1" Pulley 38 and a 57-tooth Gear 39. The Gears 39 are not placed exactly in line, so that a  $\frac{1}{2}$ " Pinion on an 8" Rod 40 can be positioned between them without engaging either Gear. The Rod 40 is free to slide about  $\frac{1}{4}$ " in its bearings, and by sliding it to one side or the other the Pinion is moved into mesh with one of the Gears 39 to engage the drive to the drum on the same Rod as the Gear. The winding drum brakes are 3" Strips 41 lock-nutted to the Flanged Plate 16. The Strips bear against the Pulleys 38 and are connected by a stretched 6" Driving Band tied to each Strip by Cord.

The Cord from drum 42 passes over Pulley 28 and the Pulley that is mounted on the Rod in Channel Bearing 29, round a  $\frac{1}{2}$ " loose Pulley in the pulley block and is then tied to the Channel Bearing. The pulley block consists of two Flat Trunnions spaced apart by nuts on a  $\frac{1}{2}$ " Bolt that supports a small Loaded Hook. The  $\frac{1}{2}$ " Pulley is mounted on a  $\frac{1}{2}$ " Rod.

The Cord from drum 43 passes over the Pulley supported by double angle strips 27, over the Pulley at the jib head and round a 1" loose Pulley in the pulley block. The Cord is then tied to the jib head. The pulley block consists of two Flat Trunnions spaced apart by nuts on a  $\frac{3}{4}$ " Bolt that carries a large Loaded Hook. The 1" loose Pulley, with a  $\frac{1}{2}$ " loose Pulley on either side of it, is mounted on a  $\frac{1}{2}$ " Rod. The Fishplate 44 reduces the tendency for the Cord to twist.

A cover over the operating mechanism is provided by two  $5\frac{1}{2}$ " x  $2\frac{1}{2}$ " Flexible Plates connected by  $5\frac{1}{2}$ " Strips and attached to two of the Strips 19 by Angle Brackets. This cover is removed in Fig. 3 to show the mechanism clearly.

#### PARTS REQUIRED

10 of No. 1	2 of No. 18b	2 of No. 48c	1 of No. 116a
21 " " 2	2 " " 19b	2 " " 48d	1 " " 125
6 " " 2a	2 " " 20	2 " " 51	2 " " 126
5 " " 3	2 " " 20a	2 " " 52	4 " " 126a
6 " " 4	4 " " 20b	5 " " 53	2 " " 147b
17 " " 5	5 " " 22	2 " " 54	1 " " 160
2 " " 6	2 " " 22a	1 " " 57b	1 " " 162
6 " " 6a	3 " " 23	1 " " 57c	2 " " 163
10 " " 8	2 " " 24	10 " " 59	2 " " 164
4 " " 9	1 " " 24a	1 " " 62	1 " " 165
3 " " 10	3 " " 26	6 " " 63	1 " " 186
26 " " 12	2 " " 27a	1 " " 77	2 " " 188
4 " " 12a	1 " " 28	1 " " 80a	8 " " 189
2 " " 12b	8 " " 35	2 " " 80c	2 " " 190
2 " " 12c	284 " " 37a	2 " " 90	6 " " 191
1 " " 13	253 " " 37b	1 " " 94	4 " " 192
1 " " 13a	22 " " 38	1 " " 95	6 " " 197
3 " " 14	2 " " 40	1 " " 96a	1 " " 198
1 " " 15	1 " " 44	2 " " 103	2 " " 216
1 " " 15b	2 " " 46	3 " " 111	2 " " 221
2 " " 16	2 " " 48	5 " " 111a	2 " " 222
5 " " 17	10 " " 48a	5 " " 111c	2 " " 223
4 " " 18a	2 " " 48b	2 " " 115	2 " " 224
			2 " " 225.