

VOL. XLIII. No.10

OCTOBER 1958

MECCANO

MAGAZINE



EXPRESS GOODS
FROM ABERDEEN

15c

The house that Jack and Jill built . .

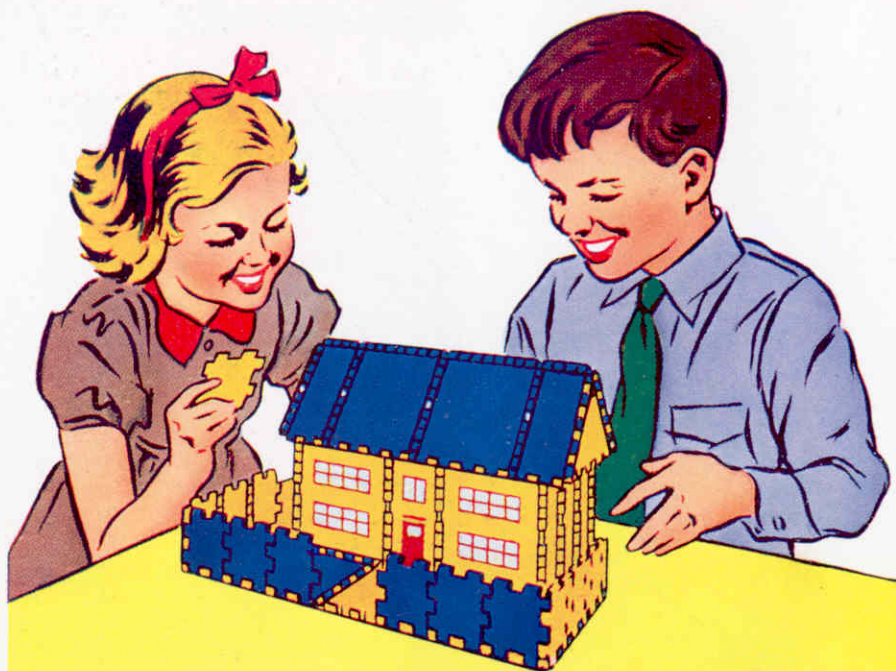

Here's the simplest of all constructional toys—DINKY BUILDER. Specially designed for young children who love to make—and pull to pieces—their own toys. Houses, furniture, wheel toys and scores of other models can be built quite easily with the brightly coloured hinged metal plates held together by steel rods.

Dinky Builder Outfit No. 1
U.K. Price 17/6 (inc. tax)

Dinky Builder Outfit No. 1A
Converts Outfit No. 1 into
Outfit No. 2.

U.K. Price 17/6 (inc. tax)

Dinky Builder Outfit No. 2
U.K. Price £1/10/6 (inc. tax)



Dinky Builder
Outfit No. 1

Made by
MECCANO
Ltd.

DINKY BUILDER

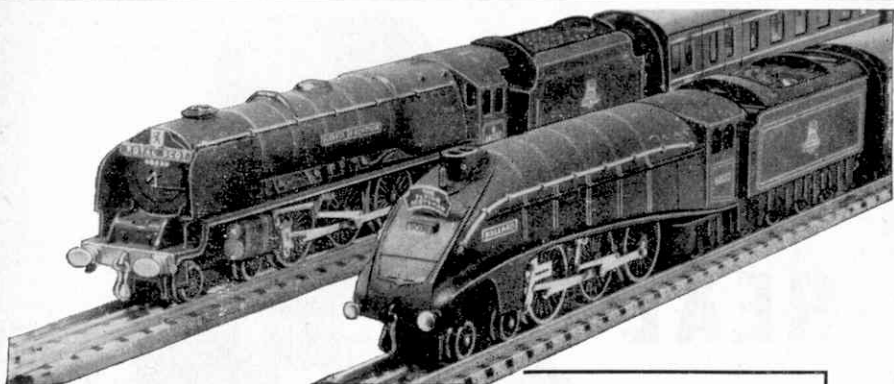

More like the real thing than ever

. . . with HORNBY-DUBLO TRAIN NAME LABELS

Add the final touch of realism to your Hornby-Dublo Expresses with the new Locomotive Headboards, Train Name and Destination Board Labels.

Metal Headboards and self-adhesive Train Name Labels are available for Hornby-Dublo Locomotives L11 "Mallard", L12 "Duchess of Montrose", and LT20 "Bristol Castle".

Metal Headboard, unlabelled, for L11 Locomotive "Mallard", 2d.

Self-adhesive labels for L11 Locomotive Headboard:

"The Flying Scotsman", 1d. "The White Rose", 1d. "The Fair Maid", 1d.

Metal Headboard, unlabelled, for L12 Locomotive "Duchess of Montrose", 2d.

Self-adhesive labels for L12 Locomotive Headboard:

"Royal Scot", 1d. "The Red Rose", 1d. "The Mancunian", 1d.

Metal Headboard, unlabelled, for LT20 Locomotive "Bristol Castle", 2d.

Self-adhesive labels for LT20 Locomotive Headboard:

"The Bristolian", 1d. "Torbay Express", 1d. "Cornish Riviera Express", 1d.

These train names are also featured on self-adhesive labels for Hornby-Dublo Corridor Coaches. In packets of 12. 1/-.

Additionally, there are self-adhesive destination board labels intended for use on Corridor Coaches with the appropriate train name labels. In packets of 12. 1/-.

King's Cross-Edinburgh
King's Cross-Leeds
King's Cross-Perth
London-Glasgow

London-Liverpool
London-Manchester
Paddington and Bristol

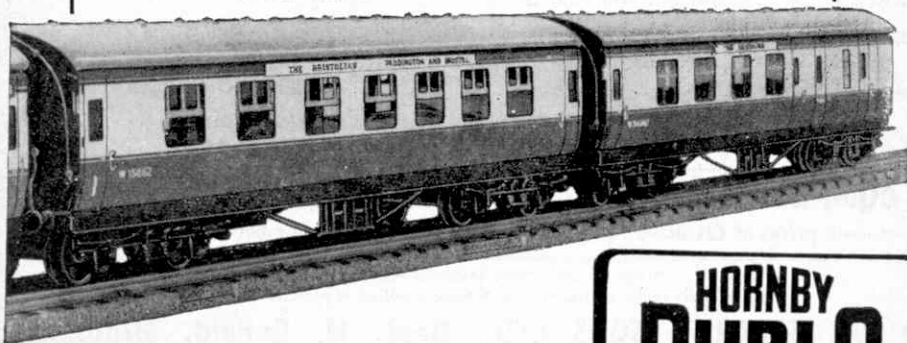

MECCANO LTD., LIVERPOOL

Prices include Purchase Tax

**HORNBY
DUBLO**
ELECTRIC TRAINS

Build
the
REAL
way



with

**BLUEPRINTS, BRICKS &
 MORTAR**

BRICKPLAYER

BRICKPLAYER is more than a toy, it is the nearest thing to real building yet devised. Each Kit comprises miniature bricks in all required shapes, mortar, roofing, plastic windows and doors, plans and instruction booklet. All models are architect designed to '0' gauge scale. Can be permanent or dismantled by merely soaking in water and bricks used again and again. Remember, ask for BRICKPLAYER and get the real thing!

Brickplayer Kit 3 ..	27/6	Brickplayer Kit 4 ..	51/6
Kit 3A converting Kit 3 into Kit 4 ..	27/6		
Brickplayer Farm Kit ..	63/-	2,000 Bricks Pack ..	55/-

Extra Bricks, Roofing and Cement in low-priced packs. Windows and doors obtainable singly.

COMPETITION Write for details of the grand Brickplayer Competition, in which you can win prizes of £21 0s. 0d., £10 10s. 0d. and £5 5s. 0d. and a number of consolation prizes.

At good toy shops, hobby shops and departmental stores.

If your dealer cannot supply, write for leaflet and address of nearest stockist to:

J. W. SPEAR & SONS LTD., Dept. M, Enfield, Middlesex
YOUR IDEAL XMAS GIFT

EXCITING ACCESSORIES FOR YOUR NEW MODEL RAILWAY

GAUGE 0

Hydraulic
Buffer Stop
Spring Action
Price 18/9

GAUGE 0

Open Wagon
8/11



Covered Wagon
10/6



Brake Van 14/-

GAUGES 00 & 0**SCENIC BACKGROUND**

4 Beautifully Printed sheets in colour to
make 12 feet
13/6

GAUGES 00 & 0

Yard
Lamp
12 volt
6/9

GAUGE 00

Working Crane
on Base. 16/-

GAUGE 00

Wrenn
Universal
Points

2-Rail 10/6
3-Rail 12/3

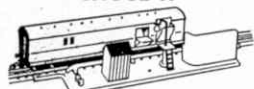
GAUGE 00

T.P.O. Mail Van 23/-
Lineside Gear 16/-

**CHAIR
FIXING JIG**

A very useful
aid to track
building.

Price 3/10

Chairs ..	5/6 per 100
Sleepers ..	5/9 per 100
Spikes ..	8d. for 500
Fishplates	1/1 per doz.
Battens	12/- per doz.

**TRACK PART SETS
EASY TO MAKE**

To Make 18 ft.
Set "A" Steel 52/6
Set "B" Brass 63/-

Set "A/E" for 3-Rail Electric.. 65/-
Set "B/E" for 3-Rail Electric.. 75/-
Postage 3/3

**POINT
LEVER**

4/3 Postage 5d.

GAUGES 0 & 00

Parts to make
Lever Frames

6 Levers 10/-
8 " 12/2
12 " 16/6

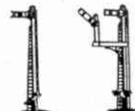
GAUGE 0

Metal Signals
Single Arm 9/-
Bracket 18/9

RAIL in 36 in. Lengths

Brass .. 17/9 Dozen
Steel .. 6/9 "

Postage for 1 Dozen 1/9

TRACK GAUGE 2/3

Send for 56 page (plus supplement) model Railway Catalogue, 2/-.

BASSETT-LOWKE LTD.

Head Office and Works: NORTHAMPTON

LONDON SHOWROOMS: 112 High Ho'bourn, W.C.2

MANGHESTER SHOWROOMS: 28 Corporation Street, 4

WORTH SAVING UP FOR

READY ASSEMBLED!

THE FODEN

**PRECISION-BUILT
CONSTRUCTIONAL
SCALE MODEL LORRY**

- UNIVERSAL COUPLING
- CROWN WHEEL AND PINION
- FULLY FLOATING REAR BOGIE

DIMENSIONS:
Length .. 14 in.
Height .. 4 in.

This Model of the FODEN F.G. 6-Wheel Standard Platform Vehicle has been designed to resemble the actual Lorry to a great degree, and such being the case the construction of the Model follows closely the procedure which is general practice in the assembly shops of heavy commercial vehicle manufacturers.

YOU CAN DISMANTLE THIS MODEL—

JUST LIKE THE REAL THING 65/-

It is made up from 65 standardised parts—all replaceable

A replica of the
DYSON (8 ton) TRAILER
it couples to the rear of the
Foden, or other mechanical
Models. 18/9.
Dismantles, too.

Your dealer will be pleased to supply, but if you have difficulties, please write to:

ABBEY CORINTHIAN GAMES CO., Victoria, London S.W.1

He's a BAYKO Boy!

There are hours of real pleasure in building with Bayko, particularly when the constructor builds to his own design. Any type of building can be modelled and used in conjunction with model car collections or railway layouts.



PRICE LIST

No. 0 Standard Set	14/-
No. 1 Standard Set	21/-
No. 2 Standard Set	31/6
No. 3 Standard Set	52/3
No. 4 Standard Set	99/3

No. 0X Converting Set	7/-
No. 1X Converting Set	10/6
No. 2X Converting Set	21/-
No. 3X Converting Set	47/-

BAYKO

FROM LEADING STORES
AND TOY SPECIALISTS

for Bright Boys-(and Girls)

Manufactured by
PLIMPTON ENGINEERING CO. LTD., LIVERPOOL 1.
CVS-57

What a super present!

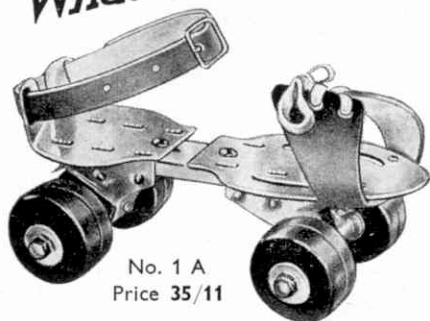

No. 1 A
Price 35/11

New

Every pair guaranteed

Reinforced plastic skates in gay colours. Light and strong. Nylon or ball bearings. Prices from 24/9.

DAVIES

ROLLER SKATES

For the smoothest, speediest, safest skating.

192 BALL BEARINGS in every double ball bearing pair. Rubber composition wheels. Prices from 21/-.

Over 10,000,000 pairs sold
throughout the world

DAVIES STEEL SPECIALITIES LTD., PEMBROKE DOCK, S WALES

A New OBSERVER BOOK

THE OBSERVER'S BOOK OF SEA FISHES

By A. LAURENCE WELLS

This is a pocket guide to the salt water fishes which can be found around our coasts. The habits and characteristics of 180 species are described. There are 64 plates, half of them in colour, illustrating 118 species. 5s. net

New Edition

THE OBSERVER'S BOOK OF RAILWAY LOCOMOTIVES

Edited by H. C. CASSERLEY

Completely revised and brought up to date, the new edition contains descriptions of each class of locomotive to be found on British Railways. With 8 colour plates and over 200 reproductions of photographs. 5s. net

FROM ALL BOOKSELLERS

FREDERICK WARNE & Co. Ltd.

1-4 Bedford Court, London W.C.2

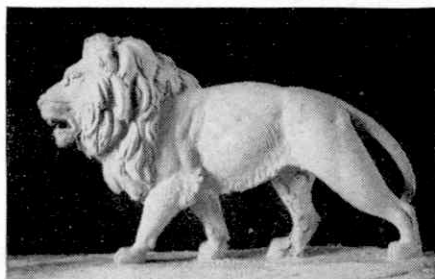

Get a **LION'S SHARE** of the fun
by modelling in
'Plasticine'

Regd. Trade Mark

This superb study is modelled in 'Plasticine', the world-famous modelling material made only by Harbutt's. You too can spend delightful hours making models like this. 'Plasticine' is hygienic and never hardens. Send for booklet 'Plasticine Modelling for Amateurs'.

PRICE 1/9 post free

HARBUTT'S PLASTICINE LTD.

Bathampton - Bath - Somerset

IF YOU THINK YOU'RE BRIGHT



READ THIS

How's this for a life when you're young? Join an Army Apprentices School and you get first-class technical training (can be electronics or any of 40 T.U.C.-recognised trades). In the picture, an apprentice is servicing a radar presentation unit. You can earn while you learn. Board, lodging and uniform are free, and you get *two months'* paid holiday every year. Later you earn good money as a key technician in the New Army. It's a real man's life with a bunch of chaps your own age and the finest chances for sport in the world. These sprint cyclists are Army Apprentices. You could be setting the pace with them.

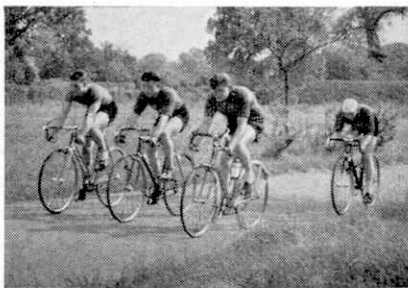

**IF
YOU'RE
14½-16½
POST
THIS
TODAY**

To the War Office (MP6) London, S.W.1

*Please send me details about the Army Apprentices School
(with no obligation on my part)*

NAME _____ AGE _____

ADDRESS _____

TOWN _____ COUNTY _____

Applications for the next Entry Examinations must be in by Jan. 13th, 1959

AAA/OP

Enjoy building the finest models with **MINIBRIX!**

Here is the toy to give you hours of fun—building castles and cottages, farm houses and factories, schools and stations with Minibrix—the all-rubber interlocking bricks.

- **HYGIENIC AND SAFE**
- **HARMLESS TO FURNITURE**
- **UNBREAKABLE**
- **ALMOST EVERLASTING**



Obtainable at all leading stores and toy shops

MINIBRIX

Registered
Trade
Mark

MINIBRIX LIMITED, PETERSFIELD, HANTS.

MBI

A BADGE TO BE PROUD OF!



This is the famous Blue Bird badge of the League of Pity, the children's own branch of the N.S.P.C.C. Every year the N.S.P.C.C. helps thousands of children from unhappy homes. Just send 2/6 with the coupon below and you too can be a member of the League of Pity. You will be entitled to wear this handsome badge. With it you will get a Blue Egg Savings Box—to help you save pennies for children who need help and protection.

**SEND
YOUR
COUPON
NOW**

To THE LEAGUE OF PITY, VICTORY HOUSE, LEICESTER SQUARE, LONDON, WC2

Please enrol me as a member. I enclose P.O. for 2/6.

NAME..... AGE.....

ADDRESS.....

PLEASE USE BLOCK CAPITALS

Here is the answer...
**TO YOUR BOAT
 PROBLEMS!**



TRADE MARK

FROG

**Complete
 with switch
 (less batteries)**

ELECTRIC POWER PACK

comprising:

Frog "Revmaster" 6v electric motor mounted on rigid plastic battery-holder, making a complete self-contained unit. Operated by two torch batteries (not supplied)

27/6

Similar unit with the New Frog "Tornado" geared electric motor.

21/-

A PRODUCT OF LINES BROS.



GROUP OF COMPANIES

Made in England by

INTERNATIONAL MODEL AIRCRAFT LTD.

MERTON • LONDON SW19 • ENGLAND

M-V ACHIEVEMENTS IN THE ELECTRICAL INDUSTRY

Manchester is the home of one of the largest electrical engineering organisations in the country—the Metropolitan-Vickers Electrical Co. Ltd.

Over the years the company has provided power for all industries, and it can claim to have contributed to progress in the fields of Nuclear Physics, Electronics and Automation. Some of the achievements of this organisation are plants totalling 430 MW, supplied during 1956 to the Central Electricity Generating Board, including a generator fitted with a new cooling system—the first in the world—which will enable these machines to be built for far larger outputs than at present; complete electrical equipments for some of the largest hydro-electric stations abroad; the design and manufacture of the control system at Calder Hall nuclear power station; the contract for the turbine generator for Canada's first nuclear power station; complete electric locomotives, Diesel-electric locomotives and multiple-

unit trains for railways all over the world, including the development of electrical equipment for operation on the new 25 kV single-phase a.c. system adopted by British Railways.

MV will also provide the main generating plant for the CEGB station at Berkeley on the Severn Estuary, which will be the first commercial nuclear power station in the world. There are wonderful opportunities for suitably qualified students to be trained for useful and well paid positions in any of these interesting and exciting fields of electrical and mechanical engineering.

The Company's training facilities are unsurpassed, and are planned to meet the needs of boys and girls from school, college students and university graduates.

On completion of training, opportunities are available for employment in the Company's laboratories, engineering workshops and offices at:

MANCHESTER · SHEFFIELD · MOTHERWELL · GLASGOW · HARLOW · LONDON

For further details, please apply to THE MANAGER, EDUCATION DEPT.

METROPOLITAN-VICKERS

ELECTRICAL CO. LTD · TRAFFORD PARK · MANCHESTER 17

An A.E.I. Company

A/A701

a model **STEAM** marine engine

OF HIGHEST QUALITY, AND PERFORMANCE

This latest addition to the famous range of "Mamod" model steam engines is the ideal power unit for model boats, with a length of 20" and over. An extremely lively unit with many refinements including chromium plated windshield, heat insulation and a complete lubrication system.

Price 45/-
including P.T.

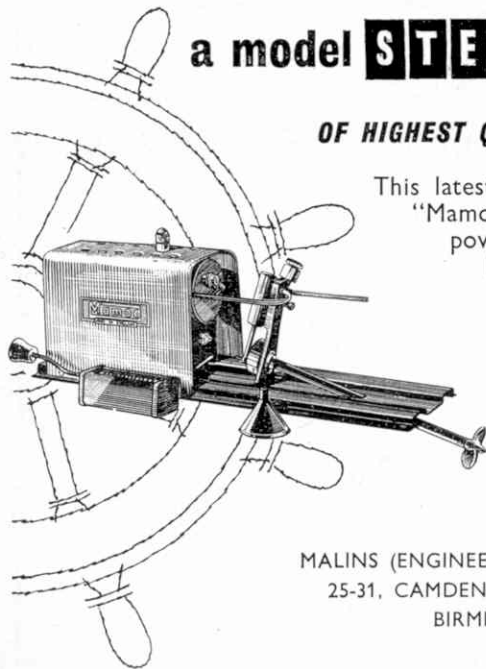

MALINS (ENGINEERS) LTD.
25-31, CAMDEN STREET,
BIRMINGHAM.

Mamod

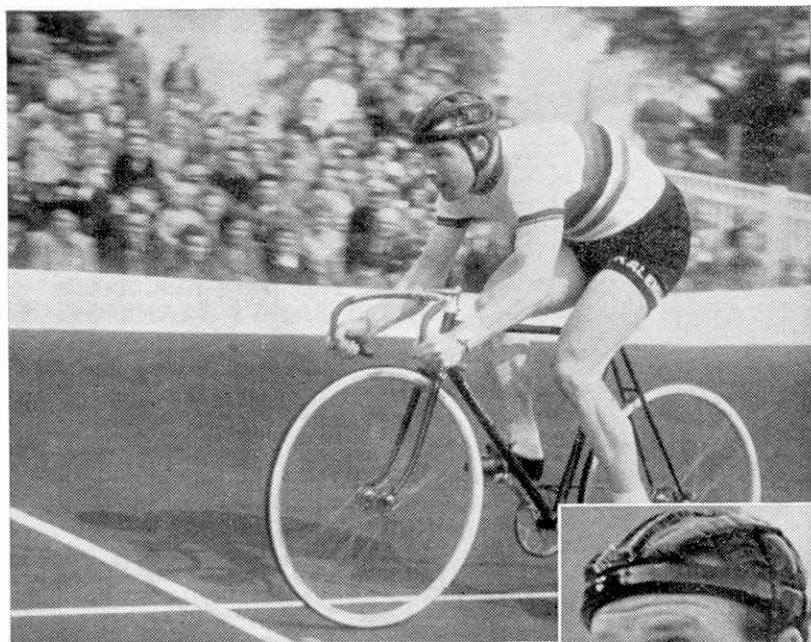

What's a bicycle's maximum m.p.h. ?

Answer's simple—as fast as two strong legs will push it. And here's Reg Harris in tough record-breaking mood, showing just how relentless big cycling can be. There's no greater test than this of human skill and strength! Yes—Racing. It's all very much our concern—in fact Reg Harris is a regular weekly contributor. There are also graphic pictures; up-to-the-moment

stories. But *Cycling and Mopeds* gives its readers much more than that. There are detailed descriptions and illustrations of new models; local club news and gossip columns. If you're keen on cycling, *Cycling and Mopeds* will add enormously to your pleasure and profit. You see, it's one of those things the keen cyclist just should not be without.

CYCLING
and Mopeds

Place a regular
order today

**EVERY
WEDNESDAY**

6d

Unconditionally GUARANTEED for 5 years!



THE NEW MECCANO T15 SAFETY TRANSFORMER

A unique method of protection against overload is incorporated in this new multi-purpose, completely short-circuit proof, Safety-Transformer. It has two separate outputs of 15-volts A.C., designated X and Y. Output X is intended for connection to an electric mechanism, motor, or controller while various electrically-operated accessories requiring only a momentary current can be operated from Output Y. The unit has an indestructible die-cast casing and is unconditionally guaranteed for five years.

Price £1.19.9

Made and Guaranteed by
MECCANO LTD., BINNS ROAD, LIVERPOOL 13
London Showroom: 22 Berkeley Square, W.1



**Two NEW
'Super-Detail'
models this month**

Two new Hornby-Dublo 'Super-Detail' Rolling Stock items are introduced this month for the delight of model railway enthusiasts. With highly-detailed moulded bodies, strong die-cast frames and smooth running nylon wheels, these vehicles join the growing range of 'Super-Detail' models which have been acclaimed the finest of their type ever produced.

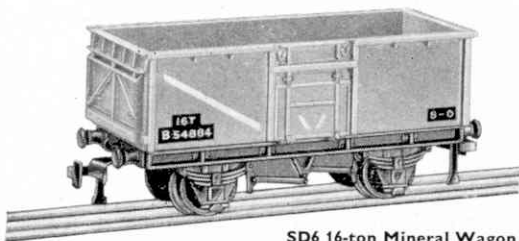

SD6 16-ton Mineral Wagon
U.K. Price 5/6 (inc. tax). Overall Length 3½ in.

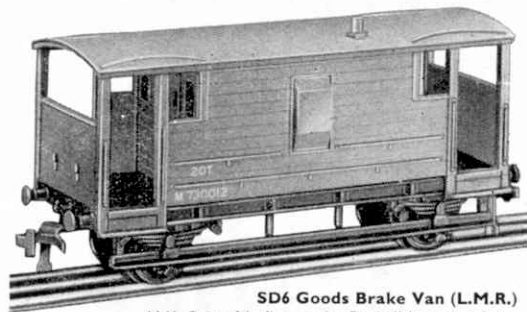

SD6 Goods Brake Van (L.M.R.)
U.K. Price 6/- (inc. tax). Overall Length 4⅞ in.

Next Month: "LOGGING IN GHANA"

MECCANO

MAGAZINE

Editorial Office:
Binns Road
Liverpool 13
England

EDITOR : FRANK RILEY, B.Sc.

Vol. XLIII
No. 10
October 1958

A Wonderful Moment

There must be very few of you who are not Dinky Toys owners and collectors, and I am sure all of you recall the exciting announcement in last month's *M.M.*

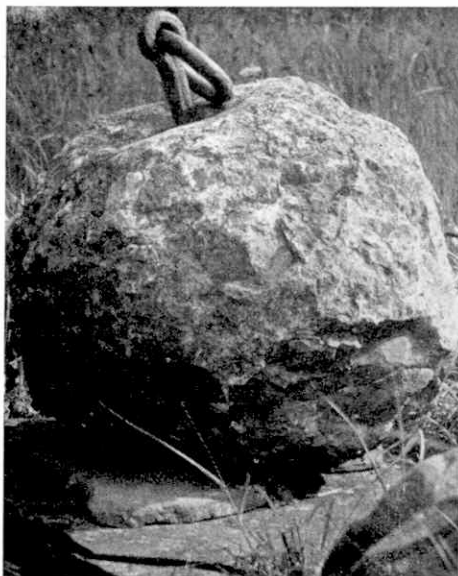

A stone that formerly helped in keeping time in Peterchurch, Herefordshire. Photograph by G. David Glover.

that some happy holder of a Dinky Toys Collector's Licence would be invited to pay a special visit to the works of Meccano Limited in Liverpool, along with his parents. This must have conjured up visions of the happiest of dreamlands in the Dinky Toys world!

At the end of August, Stirling Moss, the holder of Licence No. 1, selected the first visitor by picking out a number from those of Licences issued up to that time.

Stirling, of course, had no idea who the owner of the Licence carrying the number he gave me could be—he was in London, and I in Liverpool, while this was being arranged by telephone—and I too did not know until I had looked up the records after he had told me the number, which was 5670. There was a rather tense moment while the forms were being examined. Then out came the card with the magic number. The holder was Joseph Redhouse, of Elm Park, Hornchurch, who with his parents therefore has the distinction of being the first of the special guests of Meccano Ltd. in this exciting scheme.

I suppose that stones have always been useful. Before history began they may have been used as chairs and tables, for which purpose those that break up horizontally no doubt would please collectors most. They were also useful for throwing at animals or other men, and indeed were probably the world's first war missiles. Their great days for this purpose came in Greek and Roman times, when huge stones were shot out by catapults. I wonder if their first use led to fierce discussions about the morality of the new and terrible weapon!

It was the picture on this page that set me thinking about stones. I wonder how many of you could have guessed the purpose of the stone in this picture, which *was* a peaceful one. It weighs about 2½ cwt.

The Editor

Machines that Learn for Themselves

By Arthur Garratt

YOU have heard a lot recently about high-speed computers, or "electronic brains" as they are sometimes called. These machines can do calculations at fantastic speeds, so fast that they will do sums in a day that might take a mathematician a lifetime! But they have their limitations. They are not electronic brains at all, only slaves that have to be given complete instructions—just morons in fact. They cannot think for themselves although, when instructed they will carry

soon learn to recognise this and know that, to make the lamp light, the button must be pressed.

Many scientists believe that we do all our learning like this by associating ideas. A number of years ago, a very great Russian scientist named Pavlov did a lot of experiments with dogs. When a dog sees a bone, his mouth waters, just as your mouth waters when you smell your dinner! Pavlov discovered that if he rang a bell when he showed the dog a bone, the dog

associated the bell with food. After a bit, just ringing the bell made the dog's mouth water! The dog had learned that the sound of the bell meant food.

Animals do not have to learn all associations—some of them are "built in" before the animal is born. For instance, a bird only a few days old will crouch if a T-shaped shadow passes over it, providing the top of the T goes first. This, of course, is the shape of another bird, like a hawk, that would attack the fledgling. So this built-in reflex may save the bird's life.

The learning machine also works by associations. The model has only five inputs and 31 storage units—these are the computer's memory.

Suppose we give the problem of the button that lights a lamp. We would use only two of the inputs, one from the button, the other from the lamp. If we pressed the button a number of times and the lamp lit each time, the machine would learn that pushing the button would light the lamp. It would behave just like Pavlov's dogs—it would infer that pressing the button lit the lamp.

This, of course, is a very simple example, and you would not need a very complicated machine to do this. But suppose the problem is not quite so simple. Let's imagine that the lamp does not always light. It may be run off an accumulator

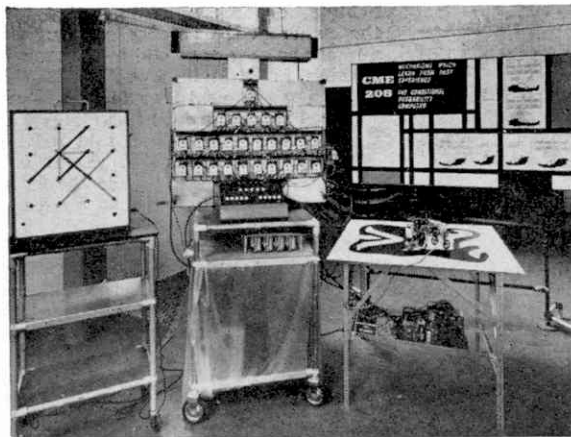

In the centre of this picture is a machine that learns for itself. It was designed and constructed at the National Physical Laboratory, Teddington. On the right is a Meccano "tortoise" controlled by it. Photograph, Crown Copyright Reserved.

out intricate calculations without making mistakes.

But other kinds of computers can be built. One being developed at the National Physical Laboratory, Teddington, is called a "Conditional Probability Computer". It has not been designed just to do complex calculations, but to make decisions based on its own experience. *It learns for itself* in something like the way that we learn.

Let's see first of all how we make decisions ourselves. Suppose that every time one thing happens, something else follows. It might be that every time we press a button a lamp lights up. We would

that runs down and needs recharging. Suppose the accumulator is charged on the first day of each month, then we would have to look at the date to see if the lamp would light. Perhaps too, we use the lamp more in the winter, and then the accumulator would run down quicker in the winter months, so we would have both to look at the day of the month and to see which month it was before we could decide whether the lamp would light!

This is getting pretty complicated and we would have to weigh up the chances each time before we could guess whether the lamp would light or not. The computer would also weigh up the chances and decide what is the *probability* of the lamp lighting in the given *condition*—that's why it's called a Conditional Probability Computer. It would use the "experience" that it had stored in its memory and infer whether the lamp would light.

To make sure that old information does not count as much as new, the memories in the machine are made to die away gradually—just like ours do! So it takes



A scientist at the National Physical Laboratory watches the Meccano tortoise on its way around the edge of a black pattern. Photograph by F. C. Livingstone.

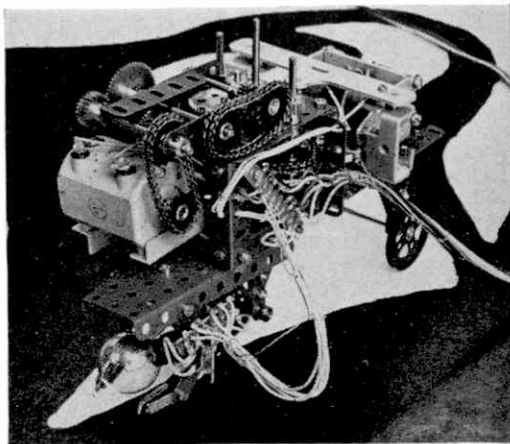

A larger picture of the Meccano tortoise, which under the control of the new machine learns to follow the line dividing black from white on the pattern over which it crawls. Photograph, Crown Copyright Reserved.

more account of recent events than of those that happened some time ago.

You can see that a machine like this, if it were complicated enough, could do some things better than we can. The kind of job it might do is to control an industrial process such as an oil refinery. This is a job that needs judgment and experience, and such a computer would learn to do it better than a man.

The machine at the moment cannot do anything as difficult as this, but the principles are now established and a bigger machine is on the way. One of the things the present computer does, to show its paces, is to control a mechanical tortoise, made of Meccano. This tortoise is driven by an electric motor and runs on a table covered with a complicated pattern in black and white. It has one built-in instruction, which is to follow the boundary between black and white. It "looks" at the table with two photocells and then learns which way to turn to keep on the line. It is guided by steering the single front wheel—rather like a 'Mechanical Horse'—through a Meccano gear train. This gear train can be reversed, so when the computer has learnt the "rules", the gears are switched over, the rules are reversed and it has to learn all over again. The tortoise is made almost entirely of Meccano, except for the driving motor and the photocell equipment. It is connected to the computer by a multicore cable that trails after it.

The machine can (Cont. on page 504)

A British Moon Rocket Plan

By the Editor

LOOKING back, it is astonishing to see how rapidly we appear to have plunged into the rocket age. Since the war rockets to make high flights over long distances have been developed, chiefly as weapons to be used in war. This was spectacular enough as the range and deadly character of the rockets were increased, but the

once everybody throughout the civilised world realised how far rocket science had been carried—and wondered what was still to come.

These fantastic developments were not the result of sudden thoughts and sudden efforts. Scientists indeed had been working for years to improve rockets, and to make them capable of carrying greater masses into the upper regions of the atmosphere, not just with warlike purposes in mind but also to allow for scientific exploration of the higher regions of the atmosphere, and indeed of space itself. For instance, the first aim of those designing Earth satellites, and the means of setting them on the paths round the Earth that we call their orbits, was to learn as much as we could about our atmosphere.

Many things have already been discovered, some of them surprising. One of these was the discovery that at great heights the atmosphere was denser than had been previously thought. A special purpose was to learn something of the nature and the radiation from outer space. It has been known for a considerable time that "rays" from outer space reached us. These consist really of showers of sub-atomic particles. Only a small proportion reach the surface of the Earth, and to gain further knowledge of their character stations were set up on mountains, where more abundant evidence of their existence was soon discovered.

Satellites ascend to far greater heights than those of mountains, of course, and it has already been made apparent that at these heights the radiation is far more intense than had been thought. Indeed it may be a barrier to space travel, for intensive radiation of the kind known to exist would exert evil effects on human beings who ventured into space and might be harmful in other ways.

This difficulty of course may be overcome. One interesting suggestion is that space rockets might be sent up a kind of corridor or vertical tunnel free of radiation that stretches upward over the magnetic pole,

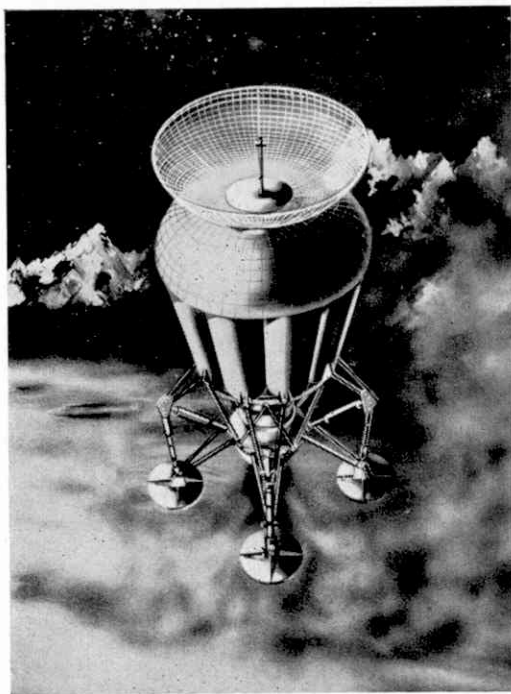

A design for a Moon rocket for landing on the Earth's satellite prepared by engineer members of The British Interplanetary Society. A drawing showing its parts appears at the head of the opposite page.

climax came in October of last year when the Russians actually shot a miniature satellite into space. The Americans were spurred on by this to speed up the efforts they had begun to send a satellite circling round the Earth, and in the end they too succeeded. Both they and the Russians have achieved other successes and all at

The particles from outer space are affected by magnets, and the magnetic field of the Earth diverts them along lines that in a general way may be compared with the magnetic lines of force of an earthly magnet. (Many of you will have traced these lines of course by scattering iron filings over a sheet of thin card, and tapping the latter so as to cause the filings to jump slightly from the card.) If this proves practicable, then rockets intended for outer space would be shot out from the neighbourhood of

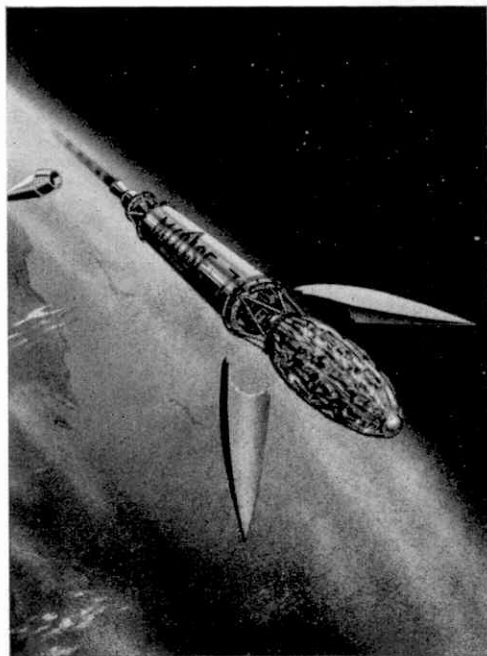
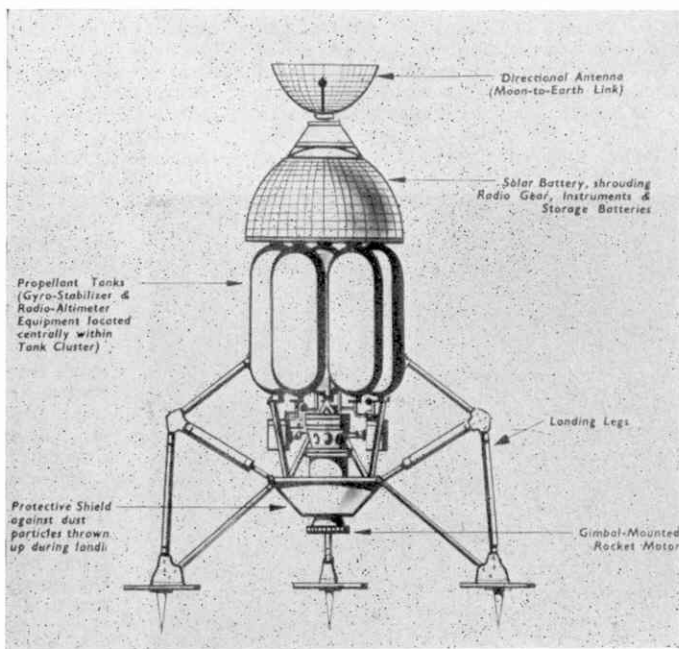

the North Magnetic Pole, which is in Arctic Canada, or of course from that of the South Magnetic Pole.

The first step outward into space would obviously take us to the Moon. Earlier in this article I wrote that investigation into rockets and their possible use in exploring space has been in progress for a considerable time. In fact, it is several years since a journey to the Moon began to be thought possible and during the last dozen years or so much fiction has been written on space travel, all very interesting and thought provoking, but not in any way technical. Some of them have even suggested that in time we may be able to travel right out of the solar system itself and to land on suitable stars or their planets, many many millions of miles away.

Whether space fiction of this kind is a pointer to the future or not remains to be seen, but the time does seem to be approaching when a flight

An artist's impression of the third stage of a rocket designed by British engineers to eject into orbit an inflatable metal foil satellite with a diameter of 6 ft. to 8 ft. Here the satellite is just beginning to be inflated.

to the Moon will be possible. Most of you will have seen accounts in newspapers of plans that have been made in the United States for sending up a rocket carrying a small vehicle, similar perhaps to the Earth satellites with which we are becoming familiar, that will travel out to the Moon,

quicker off the mark than those of other countries in this activity, although their ideas could not at the time be translated into practice, and as yet there are no British satellites—as there should be.

As long ago as 1951 three members of the Society produced a design study for a 16-ton rocket, similar in many ways to those used by the Americans and Russians, to lift into orbit round the Earth a small vehicle with a load of instruments, or a metal foil satellite that would be inflated, like a balloon, when it reached its orbit. It is interesting to recall this now that the United States Army have decided to use a Jupiter C rocket to place an inflated satellite 12 ft. in diameter into the orbit.

It has also been suggested, in America, that a man can be sent into space, to return in a capsule that is to come down to Earth by parachute. No doubt the Russians have similar ideas and it already seems clear that there will be no lack of volunteers for this perilous voyage through the upper atmosphere.

A somewhat similar scheme was suggested as long ago as 1947 by R. A. Smith and H. E. Ross, Council members of the British Interplanetary Society. The rocket was to be an enlarged version of V2, the German rocket that was used for a short time towards the end of the second World War, which would have a pressurised cabin that would be separated from the rocket on reaching the highest point attainable. The rocket was to be 57 ft. long and to have weighed 21 tons at take-off.

More recently an even more fascinating study has been made by K. W. Gatland, Vice-Chairman of the British Interplanetary Society. The result of his efforts was the design of the British "MIGRANT" rocket, which is illustrated on pages 462 and 463. Its name was contrived from the initial letters of "Moon, Instrument Guided-Rocket and Notifying Transmitter", a name that sums up the aims of the designer. The vehicles he considered ranged from rockets for carrying instruments and cameras around the Moon to robot Moon-landing vehicles capable (Cont. on page 504)

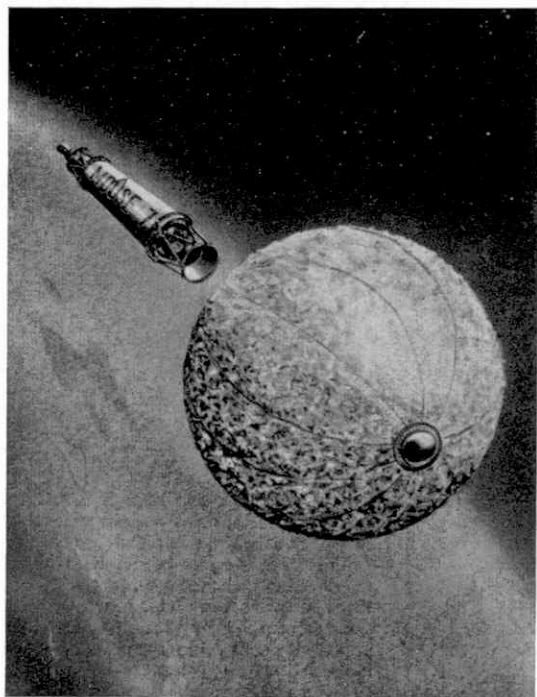

The metal foil satellite fully inflated after ejection by the third stage rocket. For the illustrations to this article I am indebted to the courtesy of the British Interplanetary Society.

encircle it and even return. A successful effort indeed may have been made before this issue of the *M.M.* appears. Even if it does not return to Earth, the instruments that such a vehicle would carry would give us a considerable amount of information of the greatest possible interest about our Moon.

Now it will perhaps be a surprise to many of you to learn that plans not only for doing this, but for actually landing a vehicle on the Moon, have been made by British scientists. Members of the British Interplanetary Society, the pioneer astronomical body in this country, have been studying such schemes for twenty-five years. British engineers indeed were



Illustration by courtesy of The Bristol Aeroplane Co. Ltd.

Helicopter Helps Road-Builders

By John W. R. Taylor

WHEN John Laing and Son received a contract to build the 53-mile Luton-to-Dunchurch stretch of the new London-Yorkshire Motorway, they took on the biggest job of its kind ever tackled by a British company.

Twelve million cubic yards of earth had to be excavated to make way for the foundations of stone and concrete on which the 2½ million square yards of asphalt and tarmac surface will be laid. In addition, 130 bridges had to be built, including six major flyovers, requiring a further quarter of a million tons of concrete and 12,000 tons of steel reinforcement.

To save time, Laings decided to divide up the new road into four main sections and to work on all four at once, using a force of more than 3,000 men and some £5 million worth of equipment. The big problem was to keep track of progress—or, at least, it was a problem until Mr. John Michie, Project General Manager in charge of operations, decided to hire a Bristol Sycamore helicopter.

At first the Sycamore was a novelty, because the number of occasions on which helicopters have been used in Britain on a major civil engineering job is very small. But the road-builders soon got used to seeing

it hopping at tree-top height between Mr. Michie's headquarters at Newport Pagnell and the quickly-cleared landing sites by the side of the road. Now, if they run into a problem, they need only get on the telephone and within a few minutes help, advice, an urgently-needed item of equipment or a spare part for an important machine is whisked to them by helicopter.

Seldom have any office records been as up-to-date as those of Mr. Michie. To check progress at every point he need only climb into the helicopter, which is flown by Bristol test pilot Bob Smith, and he can then inspect the entire job in one 90-min. flight. To do the survey by road would take the better part of four days, because much of the Motorway is far from existing roads.

Scores of other jobs have been done by the Sycamore. Mail is delivered regularly to the offices in each section. Senior executives are flown from the company's sports ground at Elstree for a quick but thorough inspection of the road work, and are back in London in less than 3½ hours after take-off. What is more, the workmen know that if an accident should occur anywhere on the job, medical aid is standing by all the time, with the only form of transport that can be guaranteed to get to them quickly.



West Country class No. 34095 "Brentor" on the 2.30 p.m. from Waterloo to Bournemouth and Weymouth passing Vauxhall. Photograph by R. F. Roberts.

Railway Notes

By R. A. H. Weight

Aboard Bournemouth 2-hr. Expresses

Long ago in London and South Western company days there were 2-hr. trains along the 108 miles 'twixt London (Waterloo) and Bournemouth (Central), to a very limited extent with non-corridor carriages hauled by D15 4-4-0 engines. The Southern Railway operated one or two with King Arthur 4-6-0s, and then in the year or two prior to the outbreak of war in 1939, the *Bournemouth Limited*, headed by Schools 4-4-0s, with heavier loads, made the run each way in just under 2 hrs. when, incidentally, the water supplies in the tender were sometimes almost exhausted, as there are no water pick-up troughs on the S.R.

In 1957, for the first time, a regular each-way service of 2-hr. expresses was introduced, including a call at Southampton that may extend to 4.5 min., with water taken by the locomotive—a much more difficult proposition. Travelling down by an extra southbound train run last summer from Waterloo at 2.30 p.m., and in the opposite direction by the 2.40 from Bournemouth, I enjoyed excellent runs behind unmodified West Country and Merchant Navy Pacifics respectively, hauling maximum loads for their type and these timings. Both were stationed and ably manned at Bournemouth, and in addition to London-and-back runs worked through to or from Weymouth in each case, with a different crew west of Bournemouth. I went on to Dorchester and returned from Weymouth as part of these journeys, a section of the trains only forming the Weymouth portion.

No. 34105 *Swanage* ran well with 11 green modern coaches weighing about 385 tons including passengers, etc. There was a slowing 42 miles out at Hook as a signal aspect was uncertain, and the driver made quite sure of a good view of the starting signal, which was at clear, before putting on steam again. This lost about 1½ min. and was in the course of a long gradual rise past

Basingstoke and the diversion from the West of England line at Worting Junction, topped at 53 m.p.h. At Roundwood signal box we had 23 miles to go, nearly all downhill or level, but only 20 min. left to arrive Southampton punctually.

After sustained maxima of 80-82 m.p.h. around Winchester, we stopped there exactly to time, having kept the tight booking of 81 min. for 79½ miles. After restarting a minute late, negotiating waterside curves and climbs into the New Forest, followed by a maximum of 75 descending to Christchurch and a lively little climb to Boscombe, we were outside Bournemouth, Central, well in time, though momentarily pulled up there by signal and

getting in at 4.31.

In the opposite direction, No. 35021 *New Zealand Line*, with 12 on, about 430 tons gross and well-filled, made a smart run to Southampton, 28½ miles in 31½ min. with speeds up and down hill varying from 44 to 72 m.p.h. The schedule allows less time to Southampton and a little more beyond, compared with that for down 2-hr. trains. The lengthy gradual ascent from Eastleigh to the high ground around Basingstoke was taken fairly easily in sunshine. Then I enjoyed a typically fast sprint along the four-track favourably-graded main line, averaging 77 m.p.h. for 38 miles to the suburbs beyond Surbiton, with a maximum of 86 near Woking. No delay of any kind occurred and the Pacific stopped in Waterloo ¼ mins. early. I had walked the platforms in Bournemouth and London within 2 hrs. and we had stopped 5 min. at Southampton—good!

Locomotive News and Doings

New locomotives lately added to stock were type 4, main line, 1 Co-Co 1: Nos. D205 allocated to Stratford, 30A; D206-7, 34B, Hornsey, operating from King's Cross; A1A-A1A type 2 mixed traffic Nos. D5511-13, to 30A, Stratford, though the first-named has been on loan to the Scottish Region at Inverness; and Nos. D8207-8, 800 h.p. Bo-Bo, freight, to 1D, Devons Road. Six-wheeled shunting: Nos. D3528, 66B, Motherwell; D3529, 66C, Hamilton; Nos. D3530-2, to Beattock and other Southern Scottish depots; No. D3573, 14D, Neasden; Nos. D3612-4, 36E, Retford; No. D3664, 41A, Sheffield; No. D3677, 51A, Darlington. No. D3525 S3A, Newton Abbot, and Nos. D3526-7, 83F, Truro. All the foregoing are diesel-electric.

Diesel-mechanical shunting No. D2410 went to 60A, Inverness, and diesel-hydraulic Nos. D2720-3 to 64A, Edinburgh (St. Margaret's).

Another steam 2-10-0 stationed at 36A, Doncaster, is No. 92195, Nos. 92224-8 went to 84C, Banbury, with others following.

The D5000-29 series of 1,160 h.p. main-line diesel electric locomotives having the Bo-Bo wheel arrangement (two four-wheeled bogies) now in hand at Derby Works will be for service on the S.R. Eastern Section, and later to a large extent between Euston and Crewe, with 10 based at Stratford, E.R. Another 84 are on order, as are 33 diesel-hydraulic (for W.R.), 30 diesel-electric, type 4, 2,000 h.p. express and 20 in the 1,100 h.p. mixed traffic range, type 2, from various firms.

Britannia 4-6-2 No. 70048, stationed at Holyhead has been named *The Territorial Army 1908-1953*.

Another W.R. 0-6-0T transferred to the Scottish Region is No. 1649; a heavier type one, formerly No. 5786, has become London Transport L92.

W.R. Cross-Country Diesel Journeys

This year has seen the development of further enterprises in the West Midlands and S. Wales, providing faster and more frequent diesel trains serving principal stations on the Shrewsbury-Craven Arms - Ludlow - Hereford and Cardiff - Newport-Abergavenny - Hereford - Worcester - Kidderminster - Birmingham routes. These are formed of "Cross-Country" multiple unit three car sets that have the advantage of a full view ahead or to the rear, as good as that of the driver or guard, when one is seated in an end motor coach, similarly to many of the local diesels now so popular. All the accommodation including a first-class section is of the open saloon type with large side windows. There is a small pantry and buffet in one coach, though not in use on the trains I saw or sampled last August. Train heating, hot water supply and pressure ventilation are provided; each power car (two in each set) has two 150 h.p. diesel engines under the floor, with fluid coupling and four-speed epicyclic gearbox.

I rode one from Shrewsbury to Hereford, past the great wooded heights around Church Stretton on the North-to-West main line traversed by L.M.R. and W.R. South Wales and West of England expresses to and from Liverpool, Manchester, etc., on to Craven Arms, where the partly single line diverges across the Welsh hills and valleys to Swansea, then through Leominster, with 70 m.p.h. maximum speeds. Leaving Hereford next morning in another set, well-filled, on the lengthy Cardiff-Birmingham journey, we switched at Shelwick Junction to another hilly and scenically-attractive route and were soon heading for the Malvern Hills, noting flower-bedecked stations, the two single

line tunnels (with traffic working electrically controlled) near Ledbury and Colwall, thence skirting Worcester on the Foregate Street-Droitwich line, passing triangular and other junctions as we proceeded North or East into what was once known as the "Black Country". It is not as bad as that now, though important industrially with plenty of freight operation and locomotives.

It is fascinating to watch the signals from a front seat, and to hear the bell ring when close to a distant signal showing clear, or the little siren sound if this is

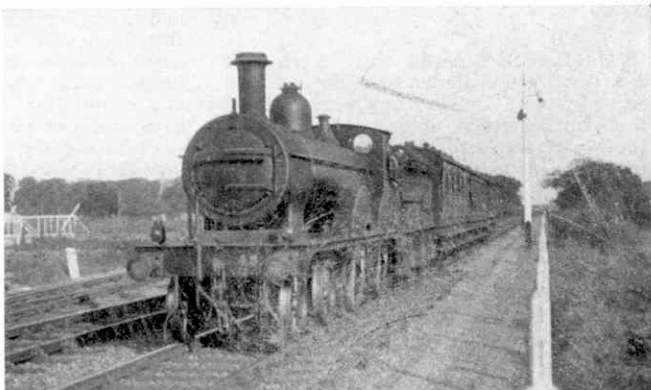

The Johnson origin of Midland and Great Northern 4-4-0 No. 43 is clearly apparent in this photograph taken in 1930 by G. H. Marillier. The engine is on a Bourne train near Sutton Bridge.

at danger. In each case the effect could be felt of the automatic train control by means of electric contacts, that is provided on all principal W.R. lines. One can observe so much else, too, including the numbers of passing engines!

"Midland and Great Northern Joint"

This line was built as a competitive cross-country one, largely single-track, to facilitate through transit from the Midlands (Midland, later L.M.S. system) and from the G.N., afterwards L.N.E.R., Peterborough and Spalding areas to the East Coast resorts, Yarmouth and Cromer, and also to Norwich. It was always known in Cambridgeshire or Norfolk as the "Joint". At the time of writing it is largely threatened with closure as it does not pay. It carries considerable traffic on summer Saturdays which would be diverted via Ely or other G.E. section route as would freight and other through trains.

Ivatt class 4 2-6-0s, B12 4-6-0s and other E.R. locomotives are mainly employed on the line through South Lynn, Melton Constable, etc. At one time the Joint line's own engines were principally 4-4-0s of decidedly Midland vintage, as shown in one of this month's illustrations. They were painted yellow and later amber. The short six-wheeled carriages were of G.N.R. type finish in varnished teak, although some were of Midland design.

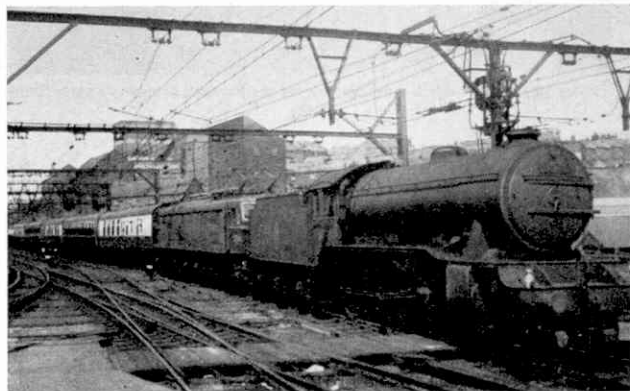

Because of engineering work "the juice" is off at Sheffield Victoria, so K3 2-6-0 No. 61988 lends a helping hand by hauling electric locomotive No. 27000 and its train into the station. Photograph by W. S. Garth.

AIRPASS

By

John W. R. Taylor

AIRPASS stands for Airborne Interception Radar and Pilot's Attack Sight System. Unlike many words formed from initial letters, it describes perfectly the equipment to which it applies, because the job of Airpass is to ensure that fighter planes are guided to their target so efficiently, and that their armament is fired so accurately, that one quick pass is sufficient to deal with any attacking bomber.

When the very first radar was used to defend these islands during the Battle of Britain, it stayed on the ground. Tall masts on the coast sent out continuous signals, which bounced back from any aircraft within range, so that the radar operators were able to see it by day or night as a 'blip' on their cathode ray screens. From the position of the 'blip' on the screen they could tell the distance, bearing and height of the aircraft and send up fighters to intercept any suspicious aeroplane.

There was time to do this, because bombers flew mostly at under 250 m.p.h. in 1940; but things are very different now.

The Avro Vulcan, for example, flies at well over 600 m.p.h. This means that it can travel from the coast at Brighton to London in under five minutes, flying so high that if a fighter pilot were given its exact position, even in daylight, he would find it difficult to spot visually in the glaring sunlight and dark skies above 50,000 ft. So he needs his own airborne radar to help track the target.

Such equipment is not new, because Beaufighters were shooting down German night bombers with the aid of an early type of A.I. (Airborne Interception) radar in

the winter and spring of 1941. But this type lacked the range and efficiency needed to deal with the modern jet-bomber, and electronics engineers have had to work hard and continuously to enable their airborne radar to keep pace with progress in bomber design and performance.

Their task would be easy if an interceptor fighter could carry an enormous radar tower and electricity generating station. Instead, they have to compress their radar into a small enough package to fit into the fuselage nose, which is about the only part of a fighter that is not full of engine, fuel, guns, radio or pilot.

Unfortunately, this was not enough, because practice interceptions showed that many fighter pilots, having been brought within range of the target by their radar, fired their guns or rockets at the wrong moment and missed it. So the designers

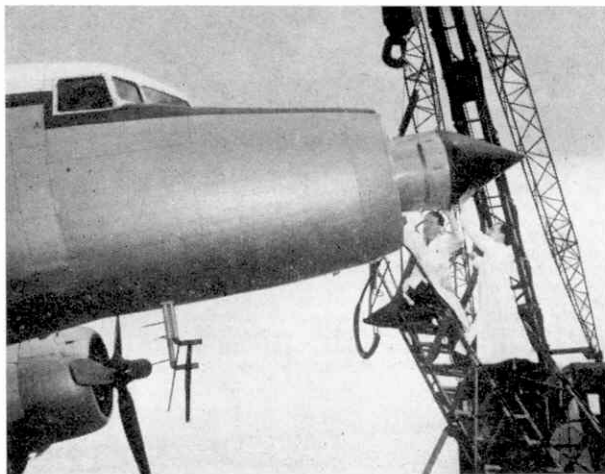

Airpass was fitted in this Dakota aircraft for the Ferranti company's early flight trials.

were asked to improve their radar so that it would also eliminate errors in marksmanship. The result was the radar fire-control system—and one of the finest, most advanced systems of this kind in the world is Airpass, which is helping to make the English Electric P.1B the most formidable bomber-destroyer yet built.

To see how it works, let us take an imaginary ride in a P.1B to try and shoot down an imaginary raider.

A few seconds after take-off, the wheels are up and we are streaking away from the ground at the rate of many thousands of

feet per minute. Already the voice of the ground controller can be heard in our earphones, telling us the general direction and height of the enemy bomber as indicated by the ground radar chain. At 50,000 ft. we level off. The Mach-meter shows a speed of Mach 1.5, about 1,000

from this moment all the information we need is presented clearly on the special sight in the cockpit. We do not even need to see the target, because Airpass calculates in a flash the correct 'aim-off' for the two Firebreak missiles carried by our fighter and ensures that they are fired at precisely the right moment. It even tells us to break off our attack if we approach the target so closely that there is danger of collision.

Once the Firebreaks have been launched, the fate of the enemy bomber is sealed. No matter how much it weaves and turns to try and elude the missiles, they will home relentlessly on the heat of its engine exhausts and blast it from the sky, offering almost 100 per cent. certainty of a 'kill' every time they are fired within range of a target.

No less remarkable than the accuracy of Airpass are its small size and weight. Unlike the usual fire-control systems, with their mass of black boxes linked by cables, it is housed entirely in the small black pointed 'bullet' that you can see inside the air intake at the nose of the P.1B. In fact, it is so small and compact that it could be fitted easily in a lightweight fighter like the Folland Gnat.

Small as it is, Airpass will form a vital part of our air defence system in the years ahead, and it represents a tremendous achievement by the Ferranti company, which designed and developed it at Edinburgh, and is also responsible for the guidance system for the important Bloodhound surface-to-air missile.



This Canberra aircraft was modified to provide a test bed for Airpass, enabling flight trials to be continued in conditions as near as possible to those in the P.1B.

m.p.h. at this height. So, as our target is flying at 600 m.p.h., every second brings us nearly half a mile closer together. It's time to let Airpass take over.

From a rotating scanner, or aerial, in the P.1B's nose, a radar beam sweeps the sky ahead over a wide angle, horizontally and vertically, for a distance of many miles. Suddenly the beam is reflected back from a point to the left of our line of flight and slightly above—the bomber has been found and the scanner stops its sweeping search. Instead, it locks its beam on to the bomber, and within seconds a computer in the radar unit has worked out automatically the course we must follow to intercept the enemy.

A slight movement of the controls is sufficient to set the P.1B smoothly and swiftly on its new course, and



English Electric P.1B interceptor armed with two de Havilland Firebreak air-to-air missiles, one on each side of the fuselage.

Railway Athletics

Human Tokens on the London Metropolitan Line

ON the southbound Metropolitan Line of London Underground at Swiss Cottage, there was until recently a section of tunnel that was 90 years old. It was part of the original single line tunnel opened from Baker Street to Swiss Cottage in 1868, and the trains passing through it were hauled by steam locomotives for many years afterwards. Later this original single line became a double one, another bore being driven alongside to accommodate the northbound track.

Single lines over which trains run in each direction are always troublesome to manage. Trains to and from the tunnel section crossed one another at St. John's Wood, the intermediate station between Baker Street and Swiss Cottage, and at that station the single line "tokens" relating to the respective sections were exchanged. Neither train could proceed until the driver had the proper token in his possession.

Now tokens take different forms, in some cases being a sort of medallion, mounted in a leather pouch and in others being rods or staffs. Those for the Swiss Cottage line single sections must have been the most unusual ever thought of, for they were actually pilotmen who rode on the engine footplates over the sections that they represented! There were two of them, distinguished by the colours of their caps, which were red for the section from St. John's Wood to Baker Street, and blue for that to Swiss Cottage. Later coloured belts were used.

To shorten the standing time at the station the men concerned developed the practice of jumping from their footplates before the engines stopped and sliding along the platforms until the end walls of the station checked them. As they did so they were always watched with admiration by passengers, and staff, who encouraged them with cheers and humorous comments, and in fact many people came specially to see the performance of the men whose work was to be taken for

rides and who added to the fun by putting on this show.

Later more orthodox tokens were substituted and eventually the second tunnel was opened.

Now the tunnel itself has in effect disappeared as well, for it became necessary to rebuild it. Part of the brickwork was broken away in sections and a new roof was formed by inserting pre-cast reinforced concrete ribs. These are supported by a new concrete wall on the side where the twin tunnel runs, and on the other by the original outer wall, special supports for the ribs being laid along the surface of this, exposed by the removal of the arch brickwork.

The work has been done from Finchley Road, under which it runs at a depth of about a foot, without interfering with traffic on the line. It could only be carried out in successive short sections, because the inner walls of the two existing tunnels were touching, giving each other a certain amount of support. So it was inadvisable to break away too much of the original tunnel at once.

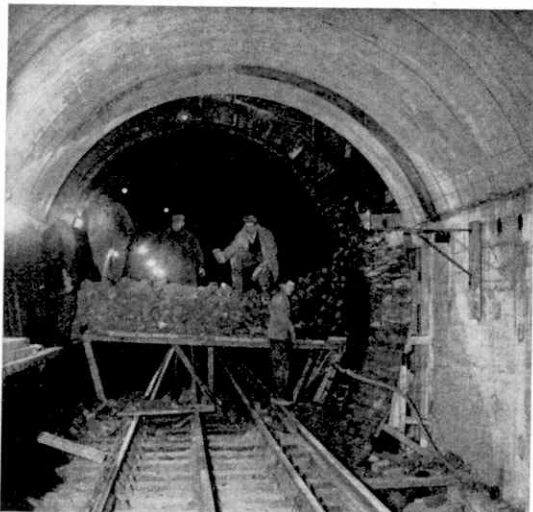

Renewing an old tunnel near Swiss Cottage on the Metropolitan Line. The section of old brickwork that has been broken down lies on the working stage ready for removal.

A £20 Million Road!

Britain's First Large Scale Motorway

By the Editor

MOVING earth and rock at the rate of half a million cubic yards a week, with the aid of 72 scrapers and 150 excavators; building 90 permanent bridges, at the rate of one every three days; taking in 10,000 cubic yards of cement, aggregates and sand by road daily and turning out 20,000 cubic yards of concrete weekly; and building a mile of double-carriageway road every 9 days. These are only a few of the many achievements called for from the builders of

in length have been built. In some instances these are being carried over the route by Bailey bridges, so that work on the Motorway can proceed without interfering with traffic.

The London-Birmingham Motorway is of outstanding interest in that it will be the first large-scale motorway to be completed in Great Britain and the first new national highway to be built here this century. Its southern end, known as the St. Albans By-Pass, will start at a point south of

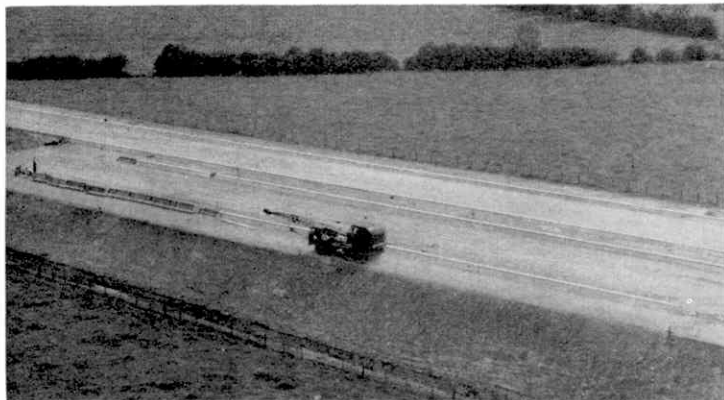

This broad highway, seen here under construction, will form part of the southern section of the London-Yorkshire Motorway, which will also provide a new route to Birmingham.

the southern part of the projected Motorway from London to Yorkshire, which is to be nearly 70 miles long. This, with extensions, will provide a new route from London to Birmingham.

Driving a great new road across country is a complicated task that can only be carried through to time by intensive work after the most careful planning. And only 19 months is being allowed for the construction of the Motorway. Work actually began on 24th March of this year, and the date when it is to be completed is 31st October of next year. Its main features are now becoming apparent. Where the route lies across hills and valleys, cuttings and embankments have been formed, work including excavation and movement of the earth scraped out on an almost fantastic scale. Where existing roads cut across the line of the Motorway, temporary diversions totalling six miles

St. Albans and will join the main trunk of the Motorway at a point near Luton, where in March last the signal for the work of construction to begin was given by Mr. Harold Watkinson, Minister of Transport and Civil Aviation. He did this by turning a switch to set off a Klaxon horn at the sound of which an "armoured column" of excavating machines came over the skyline to the south and marched over the hill towards the starting line. Simultaneously another column of machines, forming the vanguard of the northern group, approached at one side of the route and on reaching the starting line separating the northern and southern sections, all the machines lowered their buckets and began clearing the top soil. This continued until all the excavators had passed out of sight, after making a spectacular beginning of a mighty enterprise.

From the position near Luton where this

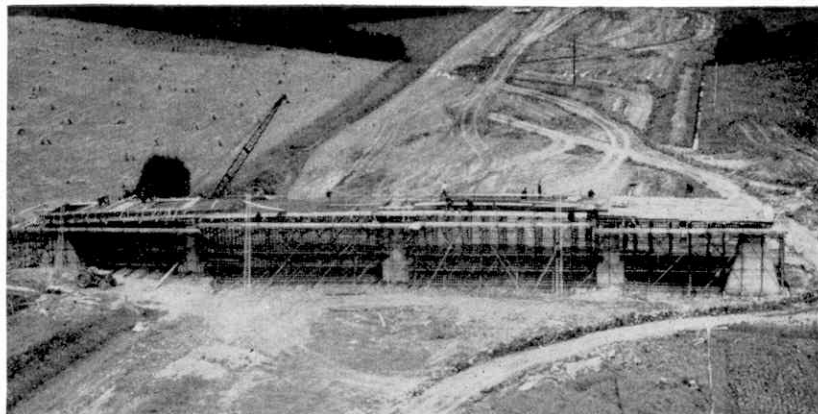

A four-span overbridge under construction.

happened the route of the Motorway follows a north-westerly direction across the Midland plains to a point near Ashby St. Ledgers, in Northamptonshire. There a short spur will branch off towards Birmingham and will join the Dunchurch By-Pass, also under construction. The main trunk of the Motorway itself will eventually be continued northward to Yorkshire.

Each carriageway of the Motorway will be 36 ft. wide, except on the St. Albans By-Pass and the Birmingham spur to the west side of Dunchurch, on which the carriageway width will be 24 ft. It will be carried over or under existing roads, and to allow for this and for the railways, rivers and canals along the route, and also to make ways for men and cattle to pass from one side of the road to the other

without walking on it, 150 bridges are being constructed.

Three river crossings on the route call for the construction of viaducts. One of these, over the River Nene, is to be 575 ft. in length, while the others, of 450 ft., will cross the Great Ouse and the River Ousel respectively. Only at a few places where particularly important highways are to be crossed will there be two-level junctions, with connecting slip roads, for the Motorway is being constructed for the use of fast through traffic and access to it is limited to a small number of entries.

The construction of the Motorway will reduce very considerably the journey time by road between London and the Midlands, and the savings in fuel and in the cost of maintaining vehicles that the new route will bring will also be very substantial.

Another feature of the great new highway will be the service areas that will be situated at intervals of about 12 miles along the route. These areas will extend on both sides of the Motorway, with a footbridge linking the two halves in each case. They are roughly circular in shape and on them



Tractors and scrapers grading a section of the new Motorway.

there will be petrol filling stations, parking areas, transport cafes and restaurants. Picnic sites also are to be provided. Parking along the highway itself will not be normal. There will, however, be room on the verges of the highway for cars that have to be brought to a standstill for any reason. It is the service areas that will provide opportunities for drivers of vehicles of all kinds using the highway to rest, or for them and their passengers to obtain refreshments or supplies.

Some of the "facts and figures" of the London-Birmingham Motorway provide interesting reading. When the whole scheme is complete, including the approaches to London and Birmingham, it will be possible to travel the whole of the 100 miles between the two cities entirely on twin carriageway roads, a feature that will appeal to drivers of commercial and private vehicles alike, especially those to whom time is of importance.

Altogether about 4,000,000 square yards of roadway will be laid. Generally this will be 2 ft. deep, based on a depth of 6 in. of compacted stone at the bottom, on which there will be a 14 in. course of either lean concrete or waterbound macadam, according to the availability of materials. Above these will be a 2½ in. tar macadam base, and the wearing surface will be provided by an asphalt course of 1½ in. The St. Albans By-Pass roadway is to consist of granular filling 7 in. deep, on which a depth of 11 in. of reinforced concrete will be spread automatically in strips up to 24 ft. long.

When the work is at its peak 3,700 men and more than 1,000 major pieces of road-making equipment will be used. Over 8,000,000 gallons of fuel will be needed to keep at work all the machinery employed in the task. An interesting point is that top soil will be preserved on different sites occupying a total area of 350 acres. This soil will eventually be used for planting

grass, trees and shrubs on the road verges and the centre strips between the carriageways.

The engineers in charge will be able to see how work is in progress at any point along the Motorway with greater ease than has been the case with any similar constructional work in the past, in spite of the length of the road, because they will make use of helicopters. How this is being done is explained in the article on page 465

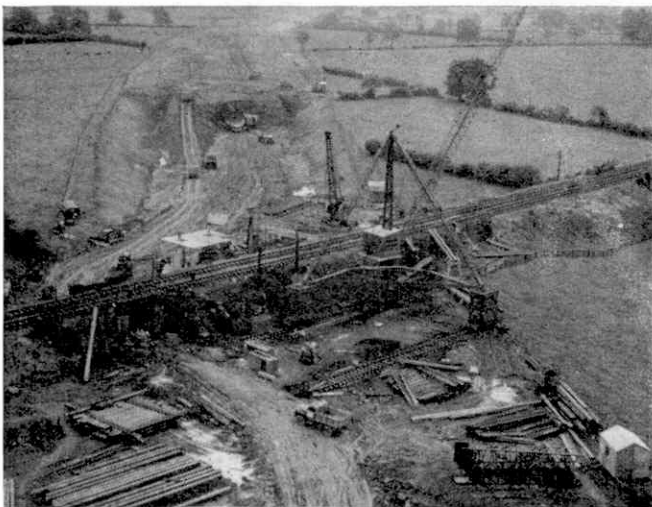

Work in progress on a railway crossing. The illustrations to this article are reproduced by courtesy of John Laing and Son Ltd., the builders of the 53-mile length of the Motorway between Luton and Ashby St. Ledgers.

of this issue, which illustrates the Bristol Sycamore, seen in the picture on that page flying low over one of the giant scrapers used in excavating operations in the early stages of constructional work.

Although there will only be nine intermediate connections with the rest of our road network, there will be no fewer than 200 flyovers and flyunders of one kind and another. There will be more than 12,000,000 cubic yards of earth to shift.

During the initial stages 113 miles of fencing were erected and 4,000 trees felled, and many services under roads crossing the routes were dismantled and restored.

More than twenty canteens will be established and mobile canteens will operate from them.

One last figure will help readers to realise the immensity of the task of building this, Britain's first large-scale motor highway. It is its cost, which will be in the neighbourhood of £20,000,000!

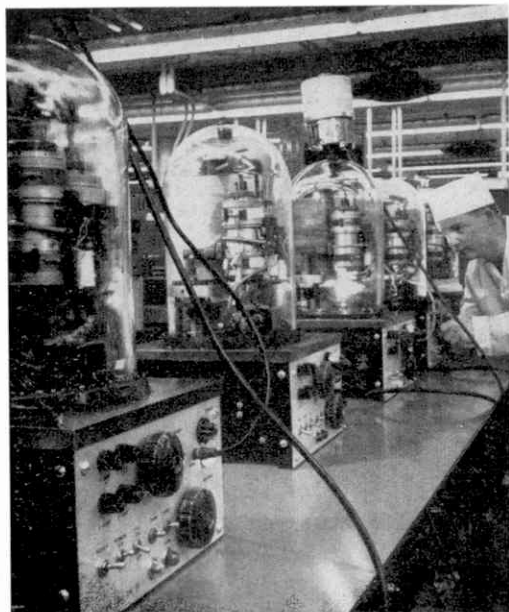

Filling a gyroscope with special fluid to eliminate friction.
Illustration by courtesy Minneapolis-Honeywell.

Liquid Propellents for Rockets

The gases to drive a rocket along are produced by burning either solid or liquid propellents. The ways in which various types of rocket work were described in these notes in August, but not the chemicals used. From an astronomical point of view liquid propellents are more important than solids because the highest possible performances can be obtained with certain of the liquids. The performance of a rocket propellant is quoted as the number of pounds of thrust produced when one pound of the propellant is burned per second. This figure is called the "specific thrust" or "specific impulse". For example, if a mixture of liquid oxygen and ethyl alcohol is burnt at one pound per second, and produces a thrust of 200 lb., then its "specific thrust" is 200 lb./lb./sec., or in its shortened and more usual form, 200 secs.

Any mixture of chemicals that will react together to produce gases, preferably at a high temperature, can be used to drive a rocket. Thousands of promising combinations of chemicals have in fact been tested on a small scale, but comparatively

Space Notes

By

J. Humphries, B.Sc.(Eng.),
A.M.I.Mech.E., A.F.R.Ae.S.

few of these have won through to wide use. Two chemicals are generally used, one an oxidant, that is, one that provides the necessary oxygen, and the other a fuel.

The obvious choice for an oxidant is oxygen itself. Unfortunately, this is a gas, and to carry it in this form large and cumbersome gas bottles would be needed. When liquified, at 183 deg. C. below zero, it is a pale blue fluid with about the same density as water; this is the form in which it is always used in rockets. The chief drawback of liquid oxygen is that in ordinary conditions of storage it is continually boiling off, and cannot therefore be stored for any great period of time. Fortunately it is cheap—about £10 per ton for large quantities—and is the oxidant for most large missiles, such as Atlas. It was used in the first stage of the launching vehicles for both the American satellites Vanguard and Explorer. For smaller rockets more easily stored oxidants are required, the most commonly used being nitric acid and hydrogen peroxide, both in a very highly concentrated form.

With any given fuel liquid oxygen will produce the greatest specific thrust of the three oxidants mentioned, nitric acid and hydrogen peroxide giving about a 10 per cent. lower performance. For example, petrol with liquid oxygen will give about 250 secs. in a modern rocket motor, but with nitric acid or peroxide only about 220-230 secs. will be produced.

Although the three above-mentioned are the only oxidants in wide use, the choice of fuels is far greater. The common cheap fuels such as petrol, paraffin and alcohols have, of course, been used to a great extent, but more unusual chemicals also have been used, for a variety of reasons. For example,

sometimes a fuel is needed that will ignite spontaneously in contact with the oxidant, and for this purpose aniline has been used with nitric acid and hydrazine hydrate with hydrogen peroxide.

Fortunately the limit of the chemical rocket has not yet been reached, and there are chemicals that will give up to 400 secs. specific thrust. These are not yet in use for various reasons. Either they are too expensive, or they burn at too high a temperature for present-day constructional materials, or they are very difficult and dangerous to handle. One of the best combinations for the future is made up of liquid hydrogen and liquid fluorine, but it will be several years before these are used on a wide scale.

How Rockets are Guided

A large slice of the cost of long-range missile or satellite lies in the guidance equipment. Most modern systems are based on what is called "inertial guidance" principles—that is the acceleration of the missile is measured along three axes perpendicular to each other by means of "accelerometers", and from these measurements the speed and position are calculated. If the position does not agree with the precomputed trajectory, then a correction to the flight path can be made, during the powered part of the path at least.

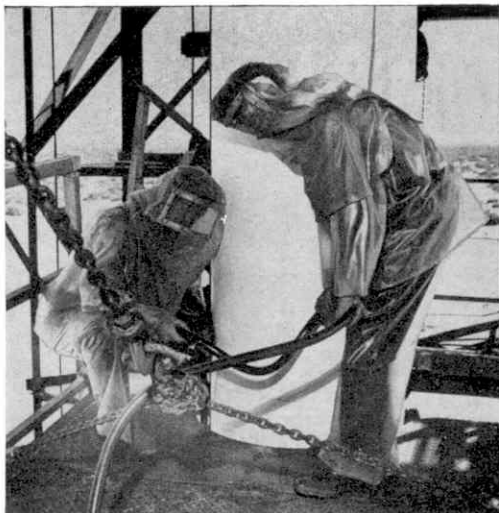

Protective clothing used while loading hydrogen peroxide into a Viking rocket. Illustration by courtesy of the Martin Co.

In flight a missile's altitude and direction are constantly changing and so a platform, stabilised so that it remains always at a constant attitude regardless of the missile's motion, is required on which to mount the accelerometers. This platform is stabilised by gyroscopes and the accuracy required of these is so great that it is only in recent years that suitable manufacturing techniques have been developed.

One of the largest manufacturers of missile gyros, Minneapolis-Honeywell, have a specially designed vibration-free plant in Florida. This building rests on 30-foot concrete piles sunk into the ground to steady it, and even the soil under the building is kept quite dry by means of pumps, since vibration travels more easily through damp than through dry soil. The testing room is isolated from the rest of the building and the vertical movement is kept down to less than 10 millionths of an inch—the horizontal movement is only one millionth! A microscopic piece of dust in the bearings of one of these gyros could be catastrophic. For this reason the air is filtered to remove particles that are greater than four ten-millionths of an inch in size.

(Continued on page 504)

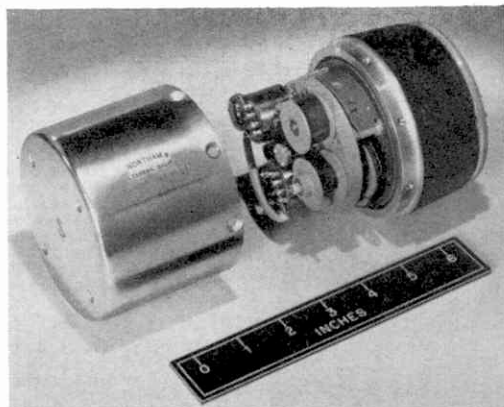

The MR-1 missile tape recorder. The special feature of this is its small size. It was designed for inclusion in test missiles during flight. Illustration by courtesy of Northam Electronics.

Air News

By John W. R. Taylor

Bristol's Biggest Helicopter

The Bristol 192, shown in the accompanying illustration, is the largest military helicopter yet built in Europe. It flew for the first time on 5th July this year, but production is already well under way and deliveries to the R.A.F. are expected to begin early in 1959.

Powered by two 1,650 h.p. Napier Gazelle NGa.2 shaft-turbines, the 192 is a general-purpose machine, equipped normally to seat 18 passengers, but capable of carrying 22 troops, 12 paratroops, 6,000 lb. of freight or up to 12 stretchers and two sitting patients in the casualty evacuation role. It could also be adapted easily for anti-submarine work, carrying underwater listening apparatus and homing torpedoes or rockets.

The two Gazelles are arranged to give 920 h.p. each for cruising flight, which gives the helicopter a range of 75 miles at 138 m.p.h. with a full load, or 430 miles with a 2,600 lb. payload. Each of its four-blade rotors has a diameter of 48 ft. 8 in. and the blades and rotor head are similar to those of the well-proven single-rotor Sycamore. Fuselage length is 54 ft. 4 in. and loaded weight 18,000 lb.

Chipmunk Goes Farming

In collaboration with Fison-Airwork Ltd., who undertake crop-spraying work all over the world, the de Havilland Aircraft Company have produced an agricultural version of their little Chipmunk trainer.

Known as the Chipmunk Mk.23, the new aircraft can be used for either spraying or dusting, the spray-bars for liquid under its wings and a chute under the fuselage for dust being quickly interchangeable. In each case the chemical is contained in a fibreglass



The twin-engined Bristol 192, the largest military helicopter built in Europe.

hopper, with a capacity of 14 cu. ft., in front of the cockpit.

Instead of the usual long cockpit glasshouse for two persons in tandem, the Chipmunk 23 has a strongly-built single canopy over the pilot, who sits high and has a good all-round view during spray-runs close to the ground. The spray-bars extend from wing-tip to wing-tip and produce a swath-width of more than 90 ft., which reduces the number of runs needed over any field.

With a full load of 560 lb. of chemicals, the Chipmunk 23 will take off in 200 yds., and lands at only 33 m.p.h. What is more, it can carry its own loader or equipment from job to job, because the hopper can be replaced by a fibreglass freight container with a flat floor, and passenger seat. Conversion either way takes less than half an hour.

Bears and Beavers Bartered

As "Bear" is the Western code-name for Russia's huge four-turboprop Tupolev atom-bomber, the thought of a group of Soviet bears flying towards New York might appear somewhat alarming. But the four which arrived at Idlewild Airport in August were brown bear cubs of the shaggy kind, destined for the Portland, Oregon, Zoo.

The young bears were flown across the Atlantic on board a cargo aircraft of Seaboard and Western Airlines, following a meeting at the Brussels Exhibition between the directors of the Portland and Moscow Zoos, at which it was agreed to exchange four prize cubs for four Oregon beavers. Seaboard also transported the beavers from New York to Brussels.

* * *

Handley Page have designed a transport version of the Victor Mk.2 crescent-wing bomber. Known as the H.P.111, it would be a low-wing aircraft, powered by four Rolls-Royce Conway turbojets, and capable of carrying 200 soldiers.



The agricultural version of the Chipmunk Mk. 23 aircraft can be used for either crop-spraying or dusting.

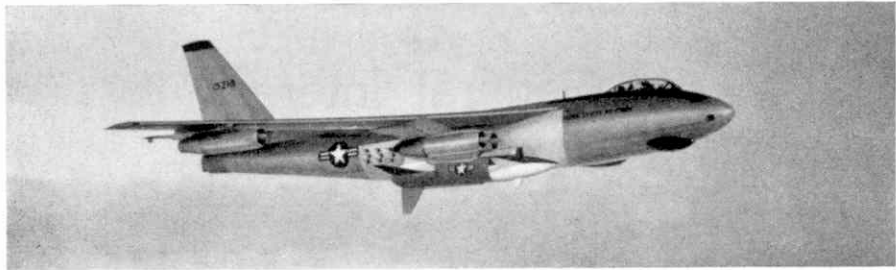

Stand-off Bomb in Service

The illustration above is of special interest because it shows a DB-47 Stratojet bomber of the U.S. Air Force armed with a Bell GAM-63 Rascal, its first stand-off bomb to enter operational service anywhere in the world. The Rascal is carried on a large pylon built on to the starboard side of the Stratojet's fuselage, under the wing.

Idea behind the stand-off bomb is to release it many miles from the target, so that the crew of the bomber can avoid having to battle past defending fighters and anti-aircraft missiles to drop their bombs. Rascal, in its present form, can be launched about 100 miles from the target, after which it cruises the last part of the way at about 1,000 m.p.h., on the power of its three-barrel rocket motor. It is a tail-first design, with a wing span of about 14 ft., length of 32 ft., and weight of six tons, complete with nuclear warhead.

London's New Heliport

It is good news that London will soon have a heliport again, thanks to the initiative of Westland Aircraft Ltd. Their plan to build a T-shaped landing platform over the Thames between Battersea Railway Bridge and Wandsworth Bridge has been approved by the Minister of Housing, and it is hoped to have the work completed by the end of this year.

The landing area, formed by the head of the "T", will measure 125 ft. by 50 ft., and will be connected to the shore by a 60 ft.-wide taxiway. Ashore will be parking space for three helicopters the size of the big Westland Westminster air-bus, or five smaller aircraft, plus 22 cars. It is expected that the heliport will be used by an average of 20 helicopters carrying a total of 125 passengers each week in 1959, and that it will serve as London's main helicopter landing site for about seven years. By then it is hoped that there will be a large permanent heliport for regular air-bus services in the heart of the city.

Supersonic Trainer

A two-seat trainer version of the English Electric P.1B fighter, known as the P.11, has been ordered into production for the Royal Air Force, to give pilots experience in flying and

The North American Sabreliner, a jet-engined trainer with its power units mounted on the rear fuselage like the French Caravelle jet-liner.



One of the U.S. Air Force's DB-47 Stratojet bombers is here seen armed with a Bell GAM-63 Rascal stand-off bomb, as described on this page. Illustration by courtesy of Bell Aircraft Corporation, U.S.A.

weapon firing at supersonic speeds before they enter an operational P.1B squadron.

The P.11 will be powered by two Rolls-Royce Avon turbojets and will be almost identical with the single-seater, except that its front fuselage will be widened to accommodate two pilots side-by-side. It will retain the full range of weapons, Airpass radar and other combat equipment, and may foreshadow a future two-seat all-weather fighter version of this superb design.

Another "Baby Caravelle"

As expected, more and more aircraft are being built with jet engines mounted on the rear fuselage, like the French Caravelle jet-liner, and the latest is the North American Sabreliner, shown in the lower illustration on this page.

Intended to meet the U.S.A.F.'s UTX specification, the Sabreliner is classed as a jet utility trainer. This means that it can be used as a small, economical machine for teaching jet navigation and handling techniques by day or night and for enabling older pilots to keep their hand in on jets, in addition to its other roles as a high-speed transport or target tug.

A variety of engines can be fitted, but the prototype will have two General Electric J85 turbojets, each developing about 2,000 lb. of thrust. They will give it a range of 1,500 miles at 575 m.p.h. at 39,000 ft.

The Sabreliner is quite small, with a span of 42 ft. 5 in., length of 43 ft. 9 in., and loaded weight of 15,330 lb., which is only half that of many single-seat fighters. It will normally carry a crew of two and four passengers in great comfort, with luggage space, cloakroom and toilet; but can accommodate up to eight passengers or 2,500 lb. of freight if required.

* * * *

The English Electric P.1B has been named the "Lightning".

Of General Interest

I AM sure that most of you will have realised that there is something unusual about the picture of a railway coach on the right. The coach itself is really one of the "cars" as the Americans call them, of the Chicago Transit Authority. The strange attachment that you have no doubt seen suspended from the frame carries a cine camera, which is used to take pictures of the wheel action while the car is running with different types of experimental bogies.

Two cords attached to the box can be distinguished. One of them is used for setting the camera in action when required, and the other for closing a shutter to exclude dirt and dust when pictures are not being taken. This interesting device

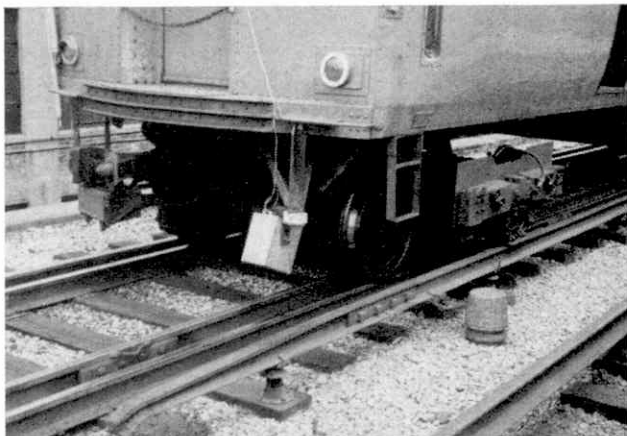

A cine camera takes pictures of wheel movements while this railway coach is running. Photograph by C. E. Keevil, Chicago.

gives valuable information in deciding upon the design of bogies for cars to be used on the track.

The stone hut in the lower picture on the page is a puzzle, as nobody so far seems to know what it was built for. There are many similar stone huts in the locality illustrated in the *From Our Readers* Section of the February *M.M.*, and this one is within a stone's throw of the All Alone signpost shown in that issue. Their roofs are of thin stone slabs.

The huts may have been used by quarrymen as store sheds, as they are mostly near old stone quarries; but why they should be round rather than square or rectangular is another puzzle. Does any reader of the *M.M.* know similar buildings, and why they were erected?

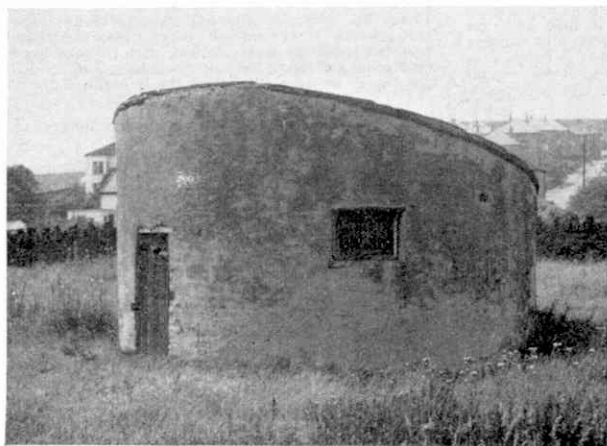

A curious circular stone hut in Yorkshire. Photograph by E. East, Idle, Bradford.

MECCANO MAGAZINE

Junior Section

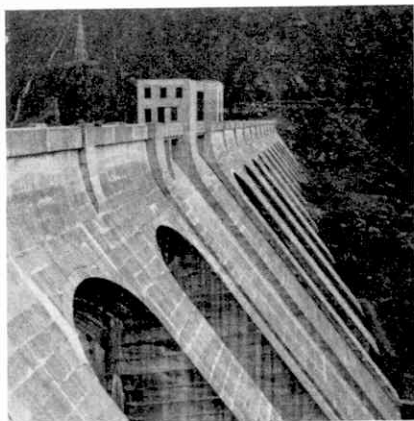

The dam of the Loch Sloy hydro-electric scheme, photographed by F. M. Cazalet, Bingley.

F. M. CAZALET, who lives in Bingley, Yorkshire, remembered an article that appeared in the *M.M.* some time ago on the Loch Sloy Hydro-Electric scheme in the Highlands of Scotland when he took a holiday in the North. During the course of this holiday he drove over the top of the Dam, which forms part of the road between Loch Sloy and Loch Lomond, and with his memories of the *M.M.* article in mind, he decided that he would have to take a photograph of this structure, which controls the water that helps to provide the Highlands of Scotland with electricity. His picture is reproduced on this page.

There is an old story of a lady who, when

she was told that the anchor of the ship in which she had been travelling had been dropped, said she was not surprised, as it had only been hanging by a bit of chain all the way, and had looked ready to drop off at any moment. The old lady could not have said this if the anchor on the vessel in which she sailed had been stowed, or "homed", as shown in the lower picture on this page. This shows how the anchors of the Royal Canadian Navy's new anti-submarine destroyer escorts are dealt with. In these modern ships the anchors do not hang from the bows, but are hoisted and stowed within the bows of the warships automatically in a few minutes.

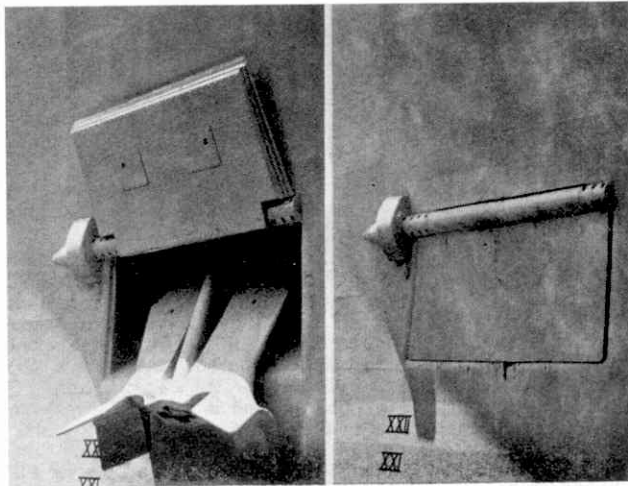

Homing the Anchor, new style. Canadian National Defence photograph.

Easy Model-Building

"Spanner's" Special Section for Juniors

An Easy-to-build Windmill

The simple Windmill shown in Fig. 1 is specially designed to be built from parts in an Outfit No. 00.

The base of the model is a $5\frac{1}{2}'' \times 2\frac{1}{2}''$ Flanged Plate to which are bolted two Trunnions 1. A $5\frac{1}{2}''$ Strip is bolted to each Trunnion and in their upper end holes the two $5\frac{1}{2}''$ Strips are joined together by two Angle Brackets, bolted together.

The sails of the Windmill are $2\frac{1}{2}''$ Strips. One of the Strips has Fishplates bolted at right-angles to each of its ends, and the other $2\frac{1}{2}''$ Strip has $\frac{3}{8}''$ Bolts in its end holes. The sails are held on a 2" Rod between two Spring Clips, and a 1" Pulley 2 is also mounted on the Rod between the two $5\frac{1}{2}''$ Strips that form the tower.

A further 1" Pulley 3 is mounted on a Crank Handle, which is journalled in the fourth holes from the

lower end of each $5\frac{1}{2}''$ Strip. The Crank Handle is held in position by two Spring Clips and two Washers.

A list of the parts required to build this model is given at the end of this article.

If a Meccano *Magic* Motor is available, it can be used to drive the Windmill and it can be fitted to the model in the following manner. The Motor should be bolted by its flanges to the $5\frac{1}{2}'' \times 2\frac{1}{2}''$ Flanged Plate, and the $\frac{1}{2}''$ Pulley supplied with the Motor should be fixed on the Crank Handle. A

Driving Band or a belt of Cord should be used to connect the $\frac{1}{2}''$ Pulley to the driving pulley of the Motor.

Platform Weighing Machine

To make the neat model Platform Weighing Machine shown in Figs. 2 and 3, first take a $5\frac{1}{2}'' \times 2\frac{1}{2}''$ Flanged Plate 1 and bolt to each of its long sides a $5\frac{1}{2}'' \times 1\frac{1}{2}''$ Flexible Plate. The

Plates should be placed so that they overhang the lower end of the Flanged Plate by two holes. To each side of the machine two $5\frac{1}{2}''$ Strips 2 are bolted, and these extend two holes beyond the upper ends of the $5\frac{1}{2}'' \times 1\frac{1}{2}''$ Flexible Plates. A $2\frac{1}{2}'' \times \frac{1}{2}''$ Double Angle Strip 3 is used to join the upper ends of the rearmost $5\frac{1}{2}''$ Strips and to it is bolted a Trunnion 4 and a $2\frac{1}{2}'' \times 1\frac{1}{2}''$ Flexible Plate that forms the top of the machine. A further Trunnion is bolted to the front edge of this Flexible Plate.

A $2\frac{1}{2}''$ Strip 5 is bolted to each side of the machine and to the front end of

each a vertical $2\frac{1}{2}''$ Strip is fixed. The latter Strip is connected by a $2\frac{1}{2}''$ Stepped Curved Strip to a

side flange of the Flanged Plate 1.

A $3\frac{1}{2}''$ Rod 6 is passed through the sides of the model and it carries two 1" Pulleys and two Angle Brackets 7. The Angle Brackets are bolted together to the end of a $2\frac{1}{2}''$ Strip 8, the bolt passing through the slotted holes of the Angle Brackets. The Angle Brackets and Strip are retained in a central position on the Rod by means of two Spring Clips. The weighing platform 9 is a $2\frac{1}{2}'' \times 1\frac{1}{2}''$ Flexible Plate, which is bolted to the Strip 8, the bolt passing through the second hole from the front-end of the Strip.

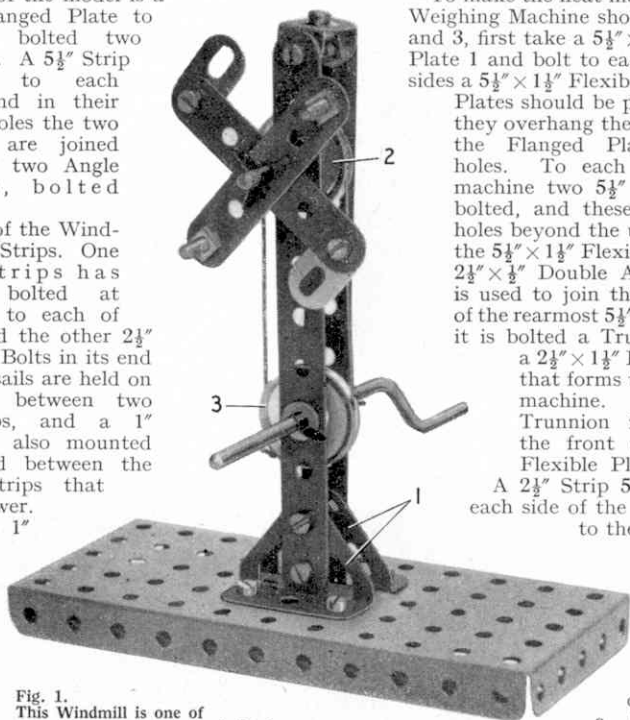

Fig. 1. This Windmill is one of the models that can be built from parts in Outfit No. 00.

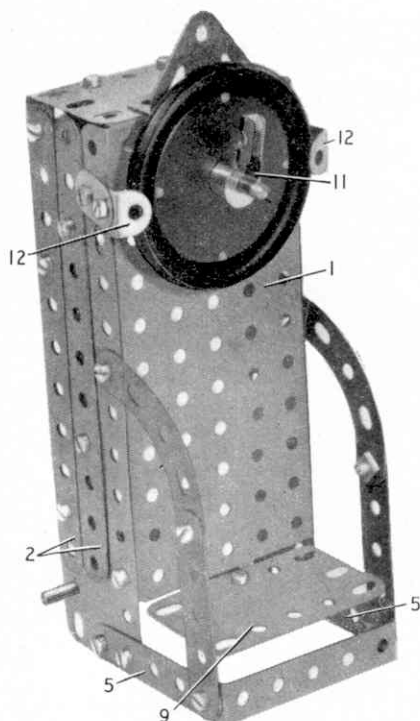

Fig. 2. A working model Platform Weighing Machine that can be built from parts in Outfit No. 2.

Another $3\frac{1}{8}$ " Rod 10 is passed through a hole in the Flanged Plate and also through the hole in the apex of the Trunnion 4. At the rear the Rod carries a 1" Pulley, and at the front of the machine a Road Wheel, a Rod and Strip Connector and a Spring Clip 11. One wing of the Spring Clip engages in the gap in the Rod and Strip Connector as shown. It should be noted that the Road Wheel is free on the Rod, but it is held against the Flanged Plate by two Angle Brackets 12, which are attached to the sides of the Flanged Plate.

A piece of Cord 13 is tied to the centre hole of the Strip 8, then taken up and wound for three or four turns around Rod 10, and the free end is then tied to a short Driving Band or piece of elastic 14. The elastic is fixed to the side of the machine casing by a nut and bolt, and serves to hold the Cord tight.

When the weighing platform 9 is depressed the Cord is pulled downward and so turns

the Rod 10 carrying the Rod and Strip Connector, which serves as a pointer. When the weight on the platform is removed the elastic pulls the Cord, and hence the pointer, back to its normal position.

Parts required to build the Platform Weighing Machine: 4 of No. 2; 5 of No. 5; 2 of No. 10; 4 of No. 12; 2 of No. 16; 3 of No. 22; 3 of No. 35; 30 of No. 37a; 29 of No. 37b; 3 of No. 38; 1 of No. 40; 2 of No. 48a; 1 of No. 52; 2 of No. 90a; 1 of No. 111c; 2 of No. 126; 1 of No. 186; 1 of No. 187; 2 of No. 188; 2 of No. 189; 1 of No. 212.

Parts required to build the Windmill: 2 of No. 2; 2 of No. 4; 2 of No. 10; 2 of No. 12; 1 of No. 17; 1 of No. 19s; 2 of No. 22; 4 of No. 35; 15 of No. 37a; 13 of No. 37b; 2 of No. 38; 1 of No. 40; 1 of No. 52; 2 of No. 111c; 2 of No. 126.

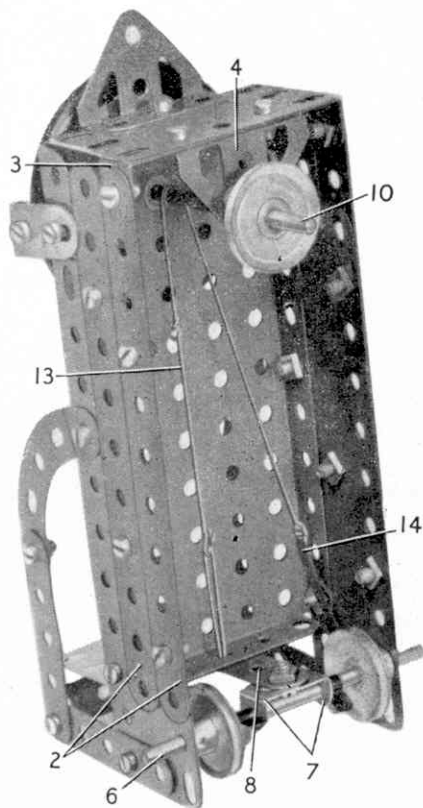

Fig. 3. A rear view of the Platform Weighing Machine, showing the mechanism.



DINKY TOYS

By **THE TOYMAN**

A New Idea in Layouts

I HOPE you are all making good use of your Dinky Toys Collector's Licences. They have been received with joy by thousands of enthusiasts, to whom they are proving to be exactly what they wanted to keep track of their possessions. If you haven't got yours yet, write to me at once and I will send you one immediately. There is no charge.

This month the latest news of the Club is given you by the Editor on page 459, so I will go straight on to the new Dinky Toys. I know that this month two very large sections of collectors are going to be even more delighted with these than usual. They are those enthusiasts who have been asking for more American cars and for additions to the mechanised Army series. Their wishes have been met in a very handsome fashion by the addition to the range of two really magnificent new Dinky Toys. One is a really splendid miniature of the famous Studebaker President Saloon, one of the big and elaborate cars of America, and the other a finely detailed model of a 7.2 in. Howitzer, Dinky Toys No. 693.

The Studebaker President is Dinky Toys No. 179, and is seen in the picture at the head of the opposite page. The military item, the 7.2 in. Howitzer, is illustrated at the top of page 484.

The President is fitted with fully glazed windows and is



John A. Vallence, Portsmouth, holds a Dinky Toys Collector's Licence and has a collection of over 90 different Dinky Toys, to which he is still making additions as the new models appear.

The 7.2 in. Howitzer, which is an attractive and important addition to the range of mechanised army equipment, is based on a real British Army weapon, and has an elevating barrel. It runs on extra large rubber tyres and is finished in Service green.

Club members and collectors generally will, I am sure, be interested in the novel scenic roadway built by Mr. A. K. Moore, Boscombe, Bournemouth, for use with Dinky Toys cars that is seen in the lower picture opposite. The device measures approximately 4 ft. by 1 ft. 6 in. At a glance you will realise that the roadway is unusual. The model indeed is a working one, which provides plenty of fun, and its description may stir some of you to work out something equally original for yourselves.

The main operating feature of the model is an endless belt of felt, which is situated under a slot cut in the straight inclined section of the roadway. The belt passes



Malcolm Lee, Bebington, Cheshire, one of the earliest applicants for a Dinky Toys Collector's Licence.

available in two colour finishes. In one of these the body is yellow with blue rear-side panels, while in the other two shades of blue provide a very attractive and distinctive finish. In both cases the rear lamps are red, and the head lamps, bumpers and beadings, etc., are aluminium. White tyres are fitted to aluminium wheel hubs.

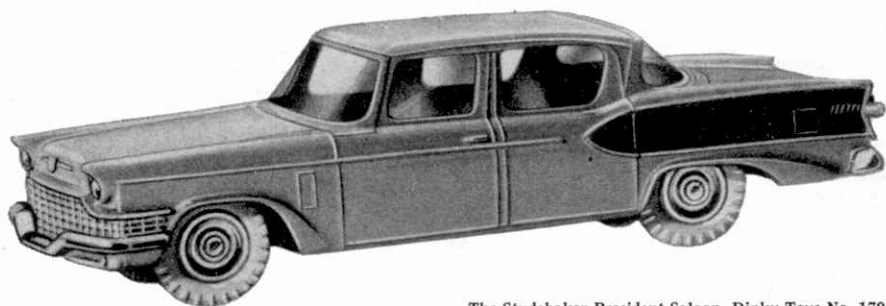

The Studebaker President Saloon, Dinky Toys No. 179. Notice particularly the finely detailed moulding of the radiator grille and the attractive rear styling. The model has fully glazed windows.

around rollers at each end, and one of these is driven by a Meccano EO20 Electric Motor. A peg fixed in the moving belt projects through the slot in the roadway, and as each car comes along the peg pushes the car up the incline. At the top of the incline the car becomes free of the peg and continues its journey under its own steam down the steep winding section of the road. Placed alongside the slot cut in the roadway are low guide rails, which serve to keep the Dinky Toys cars moving in a straight track.

The road is made of hardboard and is polished at the corners to help the cars run and turn freely. This is a bright scheme, and indeed a necessary one, as the cars are not steerable. Mr. Moore tells me that he made the mountain scenery by draping

canvas over small blocks of wood of various shapes and sizes placed on the baseboard, with a taller pillar at the highest point to form the peak of the mountain. The canvas was coated with patent fireclay applied rough so as to give a hill and valley effect. Miniature trees, fences, lakes and a house were added to give a realistic touch, and the whole scene was then painted in various colours, such as greens, greys and yellows. The effect is most realistic, as you can imagine from the picture.

As most of my readers will know, one of the best ways of playing with Dinky Toys is to use them in conjunction with a railway layout, and from time to time I receive

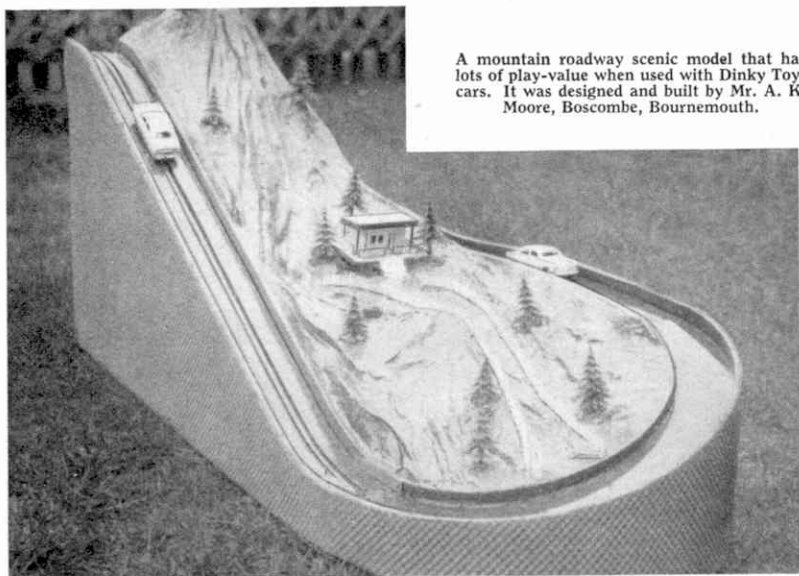

A mountain roadway scenic model that has lots of play-value when used with Dinky Toys cars. It was designed and built by Mr. A. K. Moore, Boscombe, Bournemouth.



Another fine addition to the Dinky Toys mechanised army models. This is the 7.2 in. Howitzer (Dinky Toys No. 693) introduced this month.

requests from Club Members who also possess a small Hornby-Dublo railway for plans of a simple layout of roads and buildings that they can assemble for themselves. To meet the requests I have built a small road and railway layout as an example, and a photograph of it is reproduced on this page.

The railway part of the layout consists basically of the contents of the Hornby-Dublo P10 Tank Passenger Train Set. To each of the straight sections of the standard oval of rails contained in this there has been added a Straight Rail EDB1, and a Straight Half Rail EDB1½. The Straight Half Rail with Roadway, EDB1½, that is contained in the Set, is just what you want to lay across the Hornby-Dublo Level Crossing that can be seen clearly in the picture. In this the gates of the Crossing are closed across the track, and the appropriate home Signal near the Crossing has warned the driver of the train to bring it to a standstill. The Crossing is protected by two such Signals, one for each direction of rail traffic.

The roadway leads across the layout to the entrance to the Hornby-Dublo Through Station that stands alongside the track on the far side. Although the railway is simple in character, and is not obtrusive, it makes an effective part of the layout as a whole.



An effective road and rail layout, which gives excellent scope for the inclusion of Dinky Toys.

The various buildings in the layout are all "home-made" from pieces of cardboard. If nothing stronger is available ordinary plain postcards will do, and if the various pieces are glued tightly together the finished buildings will be quite strong enough. If pieces of differently coloured cardboard can be used so much the better, this will save the trouble of painting the buildings.

The various fences seen in the layout are strips of corrugated packing cardboard, and the trees are bits of wire-wool, tousled out and stuck on the ends of small twigs.

This layout I have built up was specially intended to embody as many as possible of the features that have been suggested by keen Dinky Toys collectors in their letters to me. The layout is small enough to allow of its use in the average home, and I have tried to keep it as simple as possible without detracting from its play value. I am sure you will be very pleased to see this layout, and I know that you will have great fun building it.

Recently I have had quite a lot of letters from collectors who are all anxious to tell me how delighted they are with the new American cars, that have recently been included in the Dinky Toys range. I am glad that these cars have met with such general approval and I can assure you that there are more to follow in due course.

"Tommy
Dodd"
writes
about:



Rails and Restrictions

IN our talk last month I mentioned the Acute Angle and Right Angle Crossings of the Hornby Gauge 0 System. You know that these Crossings are referred to as being of 1 ft. or 2 ft. radius respectively, according to the radius of the Curved Rails with which they are intended to be used. Each "arm" or intersecting track on the Crossings themselves is straight, of course.

Anyway, above is a picture showing a 2 ft. radius Acute Angle Crossing in use and you will note that the Curved Rails connected to one of the intersecting arms are of the 2 ft. radius variety. The other is quite straight throughout. There is nothing unusual in this, as the Crossings are readily adaptable for use in quite a number of different ways. I need not remind you of the variety of rail arrangements possible with the different rail components of the Hornby System.

The second illustration bears this out to some extent because it shows two Points of the 2 ft. radius kind, one PR2 and one PL2, used in a slightly unusual manner. The curved section of the PL2 in the foreground is connected to the straight section of the PR2 on the other track, the two forming in effect a crossover between the two tracks. Evidently the inner track is the main line, as a No. 51 Locomotive is making good progress along it with an express passenger

train. You will notice that there are two Passenger Brake Vans next to the tender, the first being of the No. 41 type, while the second is a No. 51.

There is no reason at all why these two types should not appear in the same train. No doubt the leading Van is helping to carry an extra heavy load of parcels traffic, luggage and so on. As the No. 41 Van represents a non-corridor type, don't forget that you should only place it at one end or the other of a

train consisting otherwise of No. 51 vehicles, which represents corridor stock. You can see the outline of the gangway connections printed on the ends of the No. 51 Coaches. It would never do to place a non-corridor No. 41 Van in the middle of such a train, as this would prevent our make-believe passengers, or railwaymen aboard, moving through the train in the usual way.

Of course if you are running a parcels train or something like that, you can use No. 41 and No. 51 Passenger Brake Vans together just as you wish. The varied make-up of such real trains means that you can have a lot of fun working out how to assemble something similar on your railway. The running of trains of this kind, which can stop at your stations as required, makes a change from normal express working. And you can have one or two Dinky Toys Vans

A cattle special—or should it be a train of empty Cattle Wagons?—makes its way over the Acute Angle Crossing. Crossings add to the layout possibilities in the Hornby System.

A Hornby express passes a shunting goods train. Correct operation of the Points is important in a situation like this.

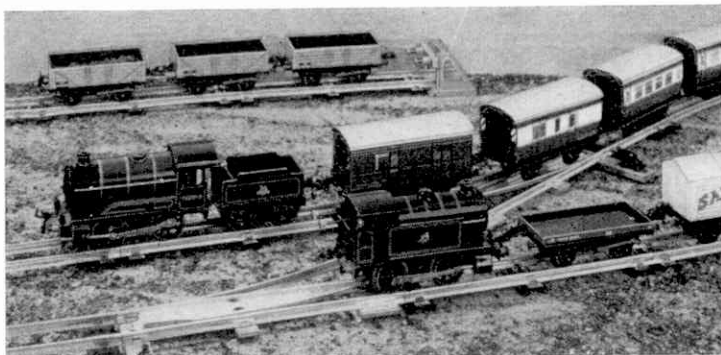

and Lorries at the stations to connect with them. The running of those road vehicles will, of course, add to the fun.

I must remind you that Nos. 41 and 51 Coaches and Passenger Brake Vans are not suitable for 1 ft. radius layouts. Although a single vehicle might be pushed around a 1 ft. radius curve by hand, it is another matter when a complete train of them is to be taken round such curves by an engine. So play for safety and observe the restriction that these vehicles should not be run on 1 ft. radius curves.

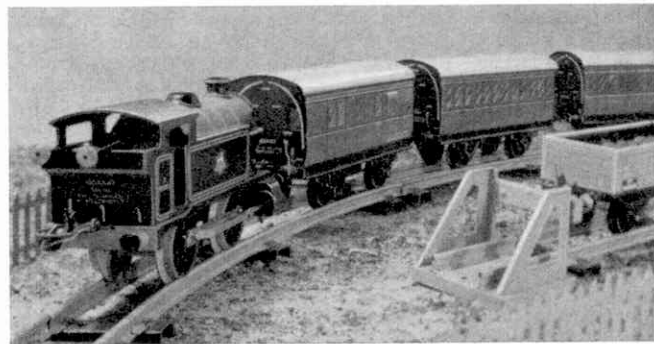

A stopping passenger train of No. 41 rolling stock is headed by a No. 40 Tank running bunker first. The "knob" on the reversing rod hides the headlamp, but the latter is there, in the correct position for this class of train.

Some real rolling stock is subject to certain restrictions, more particularly concerning the routes over which it may run. No doubt all of you will have seen on real vehicles at one time or another some such instruction as: *Not to work between Exe and Wye via Blank*. Sharp curves, platform clearances or, more likely, tunnels of restricted dimensions account for such things. They provide problems for

railwaymen, but they do add to the interest of railwaying for the observer and, of course, we can reproduce something of the same conditions in miniature.

Apart from these, there are restrictions covering the jobs for which certain vehicles may be used. Such wagons for special traffic should be kept for that traffic if at all possible. So we may like to keep a Hopper Wagon or two for "Loco Coal", or we may restrict our Low-Sided Wagon to the conveyance of Containers only, and endeavour to keep our miniature Wagons suitably "on the right lines".

Again we may find instructions regarding return to some particular depot or yard painted on certain real wagons or vans. *Return immediately to Paddington when loaded* obviously means just what it says. So if we have one or two Vans, or Wagons, that we keep for some "special" traffic, we should remember to send them back to their starting point

as soon as we can. This is a lot easier on our usual oval main line than it is in actual practice.

Our vehicles can hardly get away from their own track, but it can happen that some real ones wander farther afield than they ought to in spite of restrictions on their movements. This explains how we can see vehicles that are typical of one Region far away from their own districts.



Lighting Up Niagara

Dramatic Colour Effects in 15 Different Shades

By the Editor

THE Niagara Falls have been among the wonder places of the Earth ever since they were first seen by a European nearly 300 years ago. This was a French Canadian explorer, Father Hennepin, a Jesuit missionary, who heard the "thunder of waters", as the Indian name describes the Falls, when he was still many miles distant from them.

Higher falls than Niagara have since been discovered, but for sheer magnificence those at Niagara still hold the palm. Thousands of visitors travel to see them every year, and no effort has been spared to enhance their attractions, although nothing is really needed to increase the impression that the thundering waters of the Falls make.

The river in which these occur connects two of the famous great lakes of North America. Starting near the eastern end of Lake Erie, it flows peacefully along for about 20 miles and then churns itself into rapids as it approaches the limestone brink of the Falls. Below the Falls it flows through a deep gorge, at a bend in which it forms a vast and turbulent whirlpool that is as famous as the Falls themselves, from which

it flows onward to Lake Ontario.

The Falls are on the move. The hard limestone of their brim rests on shale, a much softer rock that is worn away by the violence of the fall, with the result that from time to time the limestone edge loses its support and breaks up. It is believed that some thousands of years ago the Falls

actually were at Lewiston, seven miles downstream, and that in the intervening period the Falls have steadily receded as their limestone bed has broken away. When Father Hennepin saw the Falls, that on the

Canadian side was a splendid crescent, which led to its being called the Horseshoe Fall, but it has now been cut back into the form of a deep notch. The fall on the United States side has not suffered so greatly, for the major part of the flow of the river is on the Canadian side. The erosion on the latter indeed has been so great that what visitors now see is not Father Hennepin's fall, but another one nearly 1,000 feet higher up river.

The idea of lighting the Falls in some way so as to provide a spectacle at night occurred to the authorities as early as 1879,

The picture at the top of the page of the American Fall and Bridal Veil seen under the new colour floodlights installed at Niagara by the General Electric Co. Ltd., England, gives a vivid idea of the brilliance of the lighting, which is 10 times as bright as that of the floodlighting system formerly in use. The illustrations on these pages are reproduced by courtesy of the General Electric Co. Ltd., England.

when twelve 2,000 candle power open arc lamps were installed, to shed what was then regarded as a most beautiful and powerful light on them after dark. On another occasion gunpowder was exploded on the rocks near the American Fall, as that on

colour", with beautiful rainbows forming in the spray rising from them. The colour screens, it should be noted, were only used on special occasions.

With the improvements in means of outdoor illumination that have been effected in more recent years, it was only natural that a new lighting system should now have been designed and installed to enhance the beauty of the Falls at night. This was supplied by the General Electric Company Ltd., England, through its Canadian associate company, and comprises 20 colour floodlighting projectors mounted in Queen Victoria Park, from which an unparalleled view of the Falls is obtained. They are mounted on a building known as the Rotunda.

To illuminate the Horseshoe Fall on the Canadian Side, which is 2,600 ft. wide and 1,700ft. from the Rotunda, there

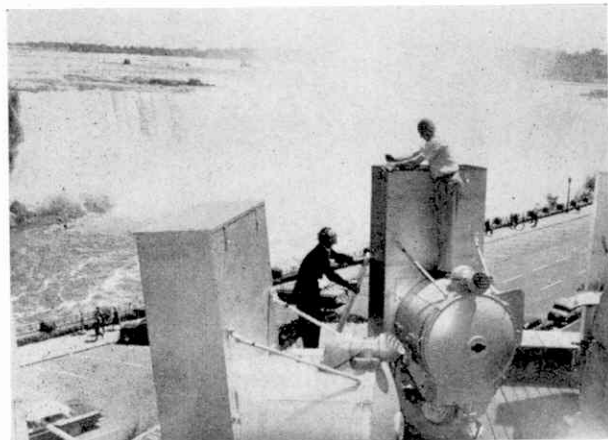

Engineers at work on one of the new colour-floodlighting projectors switched on in June last. In the background is the Horseshoe Fall.

are 10 projectors. Five others throw their light over a distance of 3,000 ft. to the 1,000 ft. wide American Fall, and two others light the rock face at the base of Goat Island, which separates the two Falls.

The lighting from the new system goes even farther, for three more projectors light up the rapids above the Falls.

When current for the projectors is switched on the Niagara (Cont. on page 504)

the United States side is called, for the benefit of a party of visitors, revealing Niagara by flashlight!

Other efforts followed, in 1907 when the Falls were illuminated from both sides by floodlights, and in 1925, when a new 1,444,000 candle power battery of projectors was fitted to spread a white light over the Falls, which were described, somewhat irreverently, as resembling an ocean of milk under their beams. No doubt more poetic descriptions were given of the Falls when seen in the light of this battery of projectors, and that would certainly be the case when screens of different colours, red, orange, green, blue and violet were interposed. Then the mighty cataract was transformed into "cascades of liquid

are 10 projectors. Five others throw their light over a distance of 3,000 ft. to the 1,000 ft. wide American Fall, and two others light the rock face at the base of Goat Island, which separates the two Falls. The lighting from the new system goes even farther, for three more projectors light up the rapids above the Falls.

When current for the projectors is switched on the Niagara (Cont. on page 504)

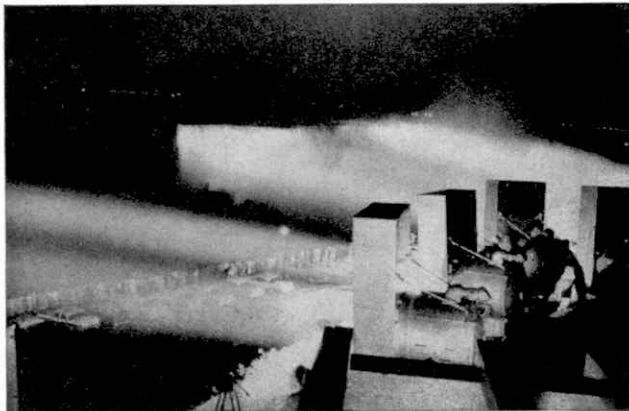

The new colour floodlights, mounted on the Rotunda, shine on the Horseshoe Fall.

£100 in Prizes for Model-Builders

The VertiVeyor Competition

MODERN factories are equipped with a multitude of ingenious devices designed for moving goods of all kinds, not only from one department to another on the same floor, but also from one floor to another. On these pages are pictures and drawings of one of the most modern of these devices, The VertiVeyor, which is made by J. Collis and Sons Ltd., London. This provides a rapid, compact and labour-saving means of conveying goods from floor to floor, and a single VertiVeyor can serve a factory having several floors, one above the other.

The appliance is designed to convey continuously up and down, and to take on its loads of goods automatically, and also to discharge them automatically, at pre-arranged points. As it operates vertically through the building, The VertiVeyor occupies a minimum of valuable floor space, and its continuous automatic action avoids interruption in production.

The VertiVeyor is an excellent subject for a Meccano model and one that is "off the beaten track" of ordinary model-building. Its various features can be reproduced in a variety of ways and with a variety of Meccano parts, so that construction of a model of The VertiVeyor offers ample scope for individual Meccano constructors to use their own ideas.

Because of this we are organising a new Meccano Model-building Competition of which it forms the subject. In the contest there are Cash Prizes to a total value of £100 for the best



Fig. 1. The VertiVeyor shown set up for display purposes. The illustration shows the feed-in conveyor in the foreground. One load is being elevated on the swing tray, another is in position ready to be picked up while a third is being held back by the interrupter mechanism.

Meccano models of The VertiVeyor sent in by model-building enthusiasts. These prizes will be awarded jointly by Messrs. J. Collis and Sons Ltd. and Meccano Ltd., and full details of them are given in the panel at the foot of this page.

Details of The VertiVeyor

The main structure or framework of The VertiVeyor is constructed from steel sections, braced and gusseted to form a rigid support for the driving motor and its gear, which are mounted at the top of the framework and can be seen quite clearly in Figs. 1 and 2. The motor drives the main drive sprockets, one of which can be seen at the top of the frame on the right in Fig. 1, and these carry,

List of Prizes to be Awarded

Section A

	£	s.	d.
First Prize, Cheque for	10	0	0
Second Prize, Cheque for	6	0	0
Third Prize, Cheque for	4	0	0
Ten Prizes, each of a Cheque for ...	2	0	0

Section B

First Prize, Cheque for	16	0	0
Second Prize, Cheque for	9	0	0
Third Prize, Cheque for	5	0	0
Ten Prizes, each of a Cheque for ...	3	0	0

Closing Date for Entries: 31st January, 1959.

one on each side of the frame, steel elevating chains, to which are attached the load carriers.

The chains pass around two further similar sprockets at the bottom of the frame, and these are mounted on a common

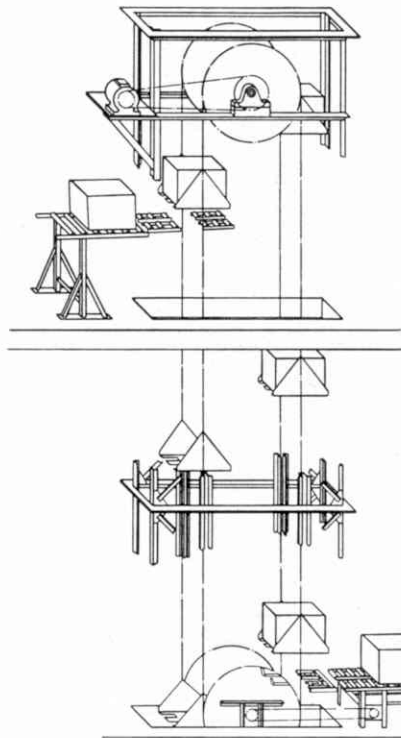

Fig. 2. A line drawing showing the general arrangement and principal features of The VertiVeyor passing through a floor of a building.

shaft that can slide vertically in slots in a bearing block so that the tension in the chains can be adjusted by forcing the sprocket shaft downwards, by means of two screwed rods. Between the two elevating chains hang the load carrier trays, the chains running in vertical guides so as to prevent sway and allow correct pick-up and set-down of the load.

The goods to be elevated approach the feed-in section of The VertiVeyor on a gravity roller track, a part of which is seen at "A" in Fig. 5, and as they near the feed-in point they are arrested by a back stop B, which rises up between the rollers.

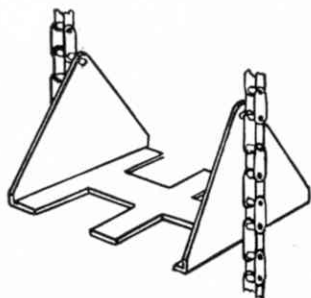

Fig. 3. One of the carriers or load trays of The VertiVeyor.

This is attached to a rocker arm C suitably pivoted at D and loaded at one end with a strong spring. At the inner end of the rocker arm is an intermediate stop E. When the apparatus is in motion the rocker arm rocks up and down and when the back stop B lowers, the intermediate stop E rises and allows the goods to advance. As the stop E lowers in its turn, the stop B rises and again holds up the line of goods, with the exception of the first item which now advances to a front stop F.

As soon as the carriers of The VertiVeyor are clear of the feed-in section, the stop F drops and a pusher G then comes into action and pushes the load on to the feeding grid H of The VertiVeyor. The load remains in the centre of this grid until such time as the next carrier, marked X in the drawing, comes up through the grid, when it is taken upward. This sequence of operations proceeds as long as the mechanism is in operation.

The drive to the feed-in

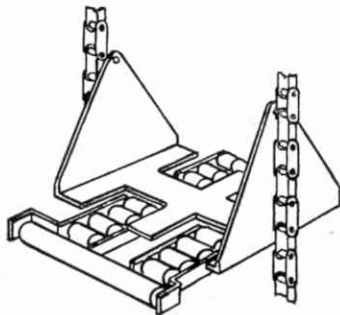

Fig. 4. A load carrier passing through a "pick-up" grid, which consists of fingers fitted with rollers. The feed-out grid is similar but is inclined slightly so that the loads run clear.

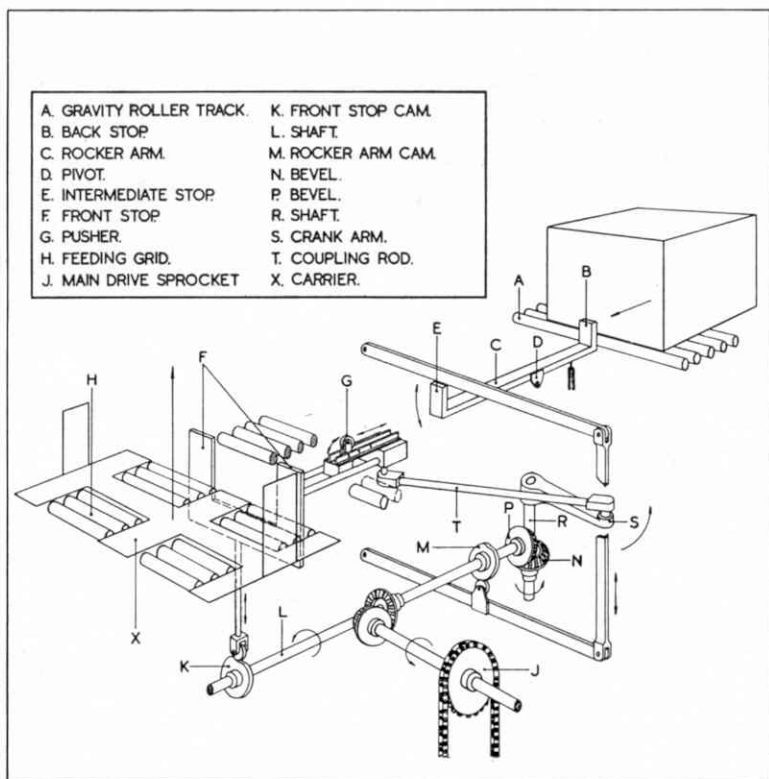

Fig. 5. A sectionalised drawing showing the mechanical details of the feed-in interrupter mechanism of The VertiVeyor.

mechanism is generally taken by chain from one of the main sprocket wheel shafts of The VertiVeyor to the sprocket J of the interrupter mechanism so that the actions of the carriers and the inflow of loads can be synchronised. By this means the loads are presented at the correct time for the carriers to pick up.

Having been picked up the loads are carried upward on the carriers and pass over the main upper chain sprockets. Continuing they then proceed in a downward direction until they meet the feed-in grid on the upper floor. The carriers pass through the grid but leave the load behind. The feed-in grid consists of steel fingers fitted with rollers and inclined at an angle so that as soon as a load is deposited on them it will run clear. It is usual to link the feed-in grid to some form of power or gravity conveyor, which carries the discharged loads to the required point.

The arrangement of the mechanism that operates the interrupter is as follows.

The Interrupter Mechanism

The rising and falling of the front stop F of the interrupter mechanism (Fig. 5) is actuated by a cam on a shaft L that carries also a second cam M that actuates the spring-loaded rocker arm C carrying the back and intermediate stops B and E. A bevel P at the end of shaft L drives a second bevel N on a vertical shaft R. Mounted at the top of this shaft R is a crank arm S, which is linked by a coupling rod T to the thruster G. As the crank S rotates its action is to cause the thruster G to slide to and fro on its slide bars, which are located under the centre gap in the feed-in rollers, the gap can be seen in the photograph reproduced as Fig. 1.

Careful study of the illustrations will reveal the main details (Cont. on page 504)

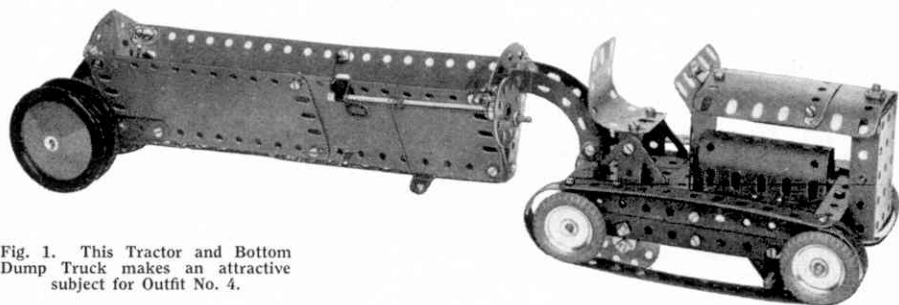

Fig. 1. This Tractor and Bottom Dump Truck makes an attractive subject for Outfit No. 4.

Tractor and Bottom Dump Truck

A Fine Model for Outfit No. 4

THE attractive Tractor and Bottom Dump Truck that is shown complete in Fig. 1 can be built from parts in Outfit No. 4.

The main frame of the Tractor is a $5\frac{1}{2}'' \times 2\frac{1}{2}''$ Flanged Plate 1. To each long side flange of this a $5\frac{1}{2}''$ Strip is attached by a Fishplate, and the bolt holding the Fishplate on one side is seen at 2 (Fig. 3). At the front end on each side a Flat Trunnion is bolted to the $5\frac{1}{2}''$ Strip and one of these is marked 3 in Fig. 3. These Flat Trunnions carry a $3\frac{1}{2}''$ Rod on which a 1" Pulley with boss is fixed. Two Wheel Discs 4 are free to rotate on $\frac{3}{8}''$ Bolts lock-nutted to Fishplates bolted to the $5\frac{1}{2}''$ Strips, in the third holes from their rear ends.

In the front and rear end holes of the $5\frac{1}{2}''$ Strips $3\frac{1}{2}''$ Rods are mounted and each of these is fitted with two 1" Pulleys with boss and Tyre.

Each of the creeper tracks is represented by two $5\frac{1}{2}''$ Strips joined at each end by a curved Formed Slotted Strip. The tracks are bolted to the ends of two $3\frac{1}{2}''$ Strips fixed across each end of the $5\frac{1}{2}'' \times 2\frac{1}{2}''$ Flanged Plate.

The front of the engine housing is a $2\frac{1}{2}'' \times 1\frac{1}{2}''$ Flanged Plate that is attached by an Angle Bracket to the end flange of the $5\frac{1}{2}'' \times 2\frac{1}{2}''$ Flanged Plate. Two $2\frac{1}{2}'' \times 2\frac{1}{2}''$ Curved Plates, bolted together as shown, form the top of the housing and this is bolted at the front to the top of the $2\frac{1}{2}'' \times 1\frac{1}{2}''$ Flanged Plate. At the rear it is fixed to an Angle Bracket bolted to a $2\frac{1}{2}'' \times 2\frac{1}{2}''$ Flexible Plate 5, which in turn, is attached at its bottom edge to another Angle Bracket bolted to the base $5\frac{1}{2}'' \times 2\frac{1}{2}''$ Flanged Plate.

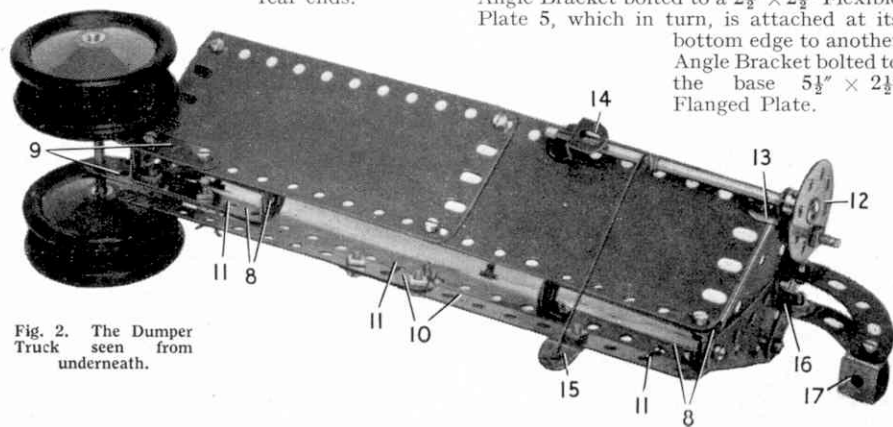

Fig. 2. The Dumper Truck seen from underneath.

The driver's seat is a $2\frac{1}{2}'' \times 1\frac{1}{2}''$ Flexible Plate gently curved to the shape shown and bolted to a $1\frac{1}{2}'' \times \frac{1}{2}''$ Double Angle Strip 6. The latter is fixed between two Trunnions bolted to the $5\frac{1}{2}'' \times 2\frac{1}{2}''$ Flanged Plate.

An attachment for the Truck is formed by a $\frac{3}{8}''$ Bolt 7, and the "engine" is represented by a U-section Curved Plate fixed by an Angle Bracket to the Flanged Plate.

Each end of the Bottom Dump Truck, which is seen in Fig. 2, consists of two $2\frac{1}{2}'' \times 1\frac{1}{2}''$ Triangular Flexible Plates bolted to the lugs of two $2\frac{1}{2}'' \times \frac{1}{2}''$ Double Angle Strips 8, arranged as shown. The sides of the Truck each consist of a $5\frac{1}{2}'' \times 2\frac{1}{2}''$ and a $4\frac{1}{2}'' \times 2\frac{1}{2}''$ Flexible Plate. These are attached to the ends by Angle Brackets, and are bolted at their lower edges to the $2\frac{1}{2}'' \times \frac{1}{2}''$ Double Angle Strips. The four Road Wheels on which the Truck runs are mounted on a $3\frac{1}{2}''$ Rod passed through the end holes of two $2\frac{1}{2}''$ Strips 9.

The opening bottom of the Truck is formed by two $5\frac{1}{2}''$ Strips 10 bolted together, overlapping three holes. This built-up strip is then hinged by loops of Cord 11 to the lower edge of one side of the Truck.

The bottom is opened or closed by turning the Bush Wheel 12, which is mounted on a $4''$ Rod. The Rod is passed through an Angle Bracket 13 and a Reversed Angle Bracket 14 bolted to the side of the Truck opposite to that to which the opening bottom is hinged. A length of Cord is tied to the Rod, wound a few turns around it, and then its other end is tied to an Obtuse Angle Bracket 15 bolted to the bottom door.

Two $2\frac{1}{2}''$ Stepped Curved Strips are bolted at each end to the lugs of two Double Brackets 16 and 17. Bracket 16 is then bolted to the front end of the Dumper Truck. The hole in the Double Bracket 17 engages the attachment pin 7 of the Tractor.

Parts required to build the Tractor and Bottom Dump Truck: 8 of No. 2; 2 of No. 3; 2 of No. 5; 4 of No. 10; 2 of No. 11; 7 of No. 12; 3 of No. 12c; 1 of No. 15b; 4 of No. 16; 5 of No. 22; 1 of No. 24; 2 of

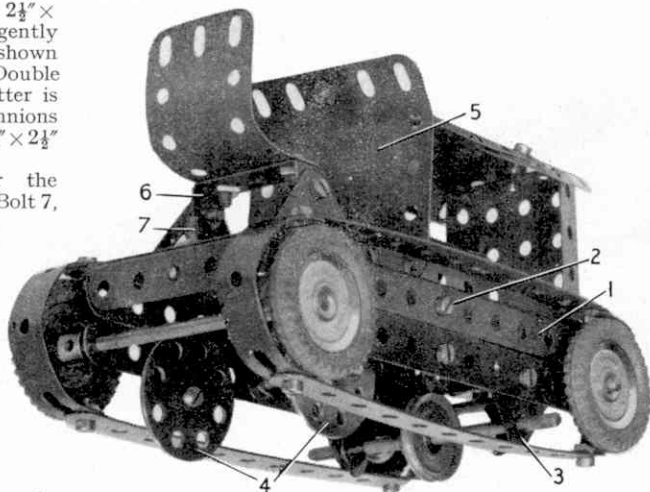

Fig. 3. Another view of the Tractor unit.

No. 24a; 5 of No. 35; 72 of No. 37a; 65 of No. 37b; 10 of No. 38; 1 of No. 40; 1 of No. 48; 6 of No. 48a; 1 of No. 51; 1 of No. 52; 4 of No. 90a; 5 of No. 111c; 1 of No. 125; 2 of No. 126; 2 of No. 126a; 4 of No. 142c; 4 of No. 187; 1 of No. 188; 1 of No. 190; 2 of No. 191; 2 of No. 192; 1 of No. 199; 2 of No. 200; 4 of No. 215; 4 of No. 221.

THE MECCANO "MECHANISMS" COMPETITION CASH PRIZES FOR GOOD IDEAS

The "Mechanisms" Competition that was first announced in the August issue of the Magazine closes for entries at the end of this month and there is just enough time still left for intending competitors to prepare and send in their entries, provided that they set to work right away. In this Contest completed models are not required and entries will be confined to mechanisms only. By mechanism we mean constructions such as gear-boxes, clutches, differentials, reversing gears, brakes and similar mechanical devices designed for carrying out specific purposes or special mechanical movements.

We wish to emphasize that it is not necessary to incorporate the mechanism in an actual model. The entry should consist of the mechanism itself only.

After you have thought out and built up a mechanism, the next thing we ask you to do is to make a neat sketch of it, or better still obtain a good clear photograph. Then write a short description of the purpose and construction of the mechanism and send this, together with the sketch or photograph, to "Meccano Mechanisms Competition, Meccano Limited, Binns Road, Liverpool 13".

Model-builders of all ages are eligible to compete. There will be two Sections: A, for competitors under 14 years of age on 31st October next, and B, for those aged 14 or over on that date. The prizes to be awarded in each Section are as follows:—First, Cheque for £4 4s. 0d.; Second, Cheque for £2 2s. 0d.; Third, Cheque for £1 1s. 0d. Ten prizes each of 10/- and ten prizes each of 5/- . The closing date for entries is 31st October,

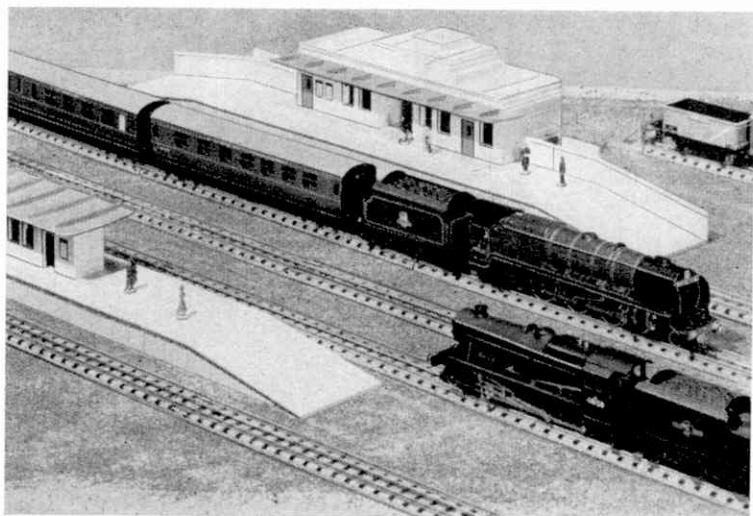

The Hornby-Dublo "Royal Scot" express, carrying engine Headboard and coach Name and Destination Boards, passes through a station, while an 8F 2-8-0 makes its way in the opposite direction.

HORNBY RAILWAY COMPANY

By the Secretary

Now You Can Name Your Trains!

DO you remember the upper picture on page 449 of last month's *M.M.*, and what was printed underneath it about the nameboards on the Coaches shown there? Well, now that these and others have been introduced into the Hornby-Dublo System, let us have a talk about them. They give a fine touch of glamour to the locomotives and coaches carrying them, introducing something of the romance of travel to distant places. And you can change your destinations with no trouble at all.

The first thing to note is that each of the express Train Sets in the System, the P15 *Flying Scotsman*, the P20 *Bristolian*, and the P22 *Royal Scot*, now includes a detachable Locomotive Headboard for the engine and the Coaches carry nameboard labels. The P15 Passenger Train Set introduces other changes, but I will deal with these separately in a later talk.

You will all be glad that the Headboards are removable, because not all your expresses will necessarily be named. The title is applied in each case by means of a special self-adhesive Label that is fixed to the metal "board" by pressure. The same arrangement is used to apply the titles to the Coaches, the Labels in this case being

printed to represent the separate name and destination boards and made to attach direct to the vehicles. They are already applied to the Coaches in the Sets concerned when you get them. They are available separately, too, for the extra vehicles that you are sure to add in order to build up a representative express train. For example, they can be fixed on the popular and effective D20 Restaurant Car.

The Labels themselves are mounted on a backing paper, from which they should be removed by rolling back this paper between finger and thumb in order to keep the Labels themselves as flat as possible. So don't attempt to peel the Labels off the paper, but rather peel the paper away from the Labels! To explain this more clearly there is a little diagram showing what I mean on each of the packets containing the Labels.

In the P20 and P22 Train Sets the provision of the Locomotive Headboards has not required any alteration to the engines themselves. Therefore these Headboards can be applied to *Duchess of Montrose* and *Bristol Castle* engines that were in service before the introduction of nameboards, but *Silver King* of the former EDP15 Train Set is not suitable for the

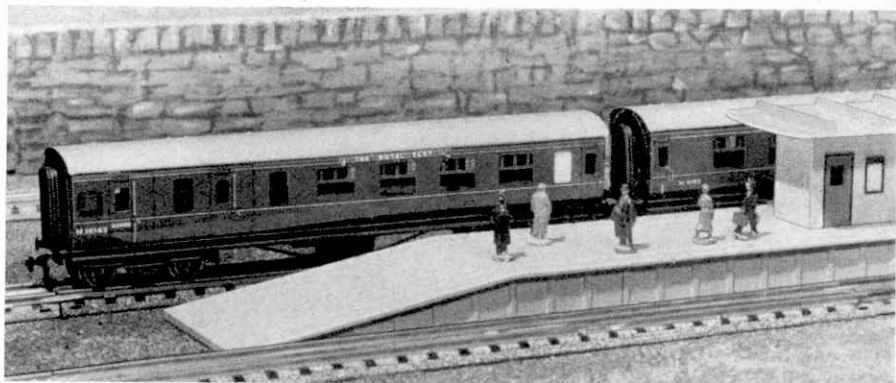

The end coach of "The Royal Scot", a D22 Brake/2nd, carrying the nameboards only, draws alongside the Island Platform. The "boards" are self-adhesive labels.

mounting of a Headboard.

For *Duchess of Montrose* in the P22 Set there is a special Headboard, with lugs to slip under those holding the smoke-deflectors to the handrails alongside the smoke-box. The *Royal Scot* Label, which is a striking affair in itself, reproduces accurately the form and colouring of the real headboard, showing the rampant lion of Scotland on a shield above the title itself and very good it looks, too, mounted on the engine front.

Similarly the W.R. type Headboard that distinguishes the engine of *The Bristolian* is made to hook on to the curved handrail that runs round the top of the smoke-box front. Here again the Label follows the actual thing and bears representations of the arms of the cities of Bristol and London respectively in the upper corners.

In addition to the names of the standard named Train Sets you will be glad to know that alternative titles also are available separately. These titles are representative of the principal services in the Regions so far featured in the Hornby-Dublo System. The Labels are of

the same self-adhesive type. They can be removed from the engine headboards or Coaches and "stored" on the backing strips and they can be used several times over. So you can easily change the titles of your trains. This is a very great convenience that adds considerably to the enjoyment of running real express trains in Hornby-Dublo.

There is no need for me to detail here and now the various titles that are available. These are listed in the current Hornby-Dublo literature and in the advertising pages in this issue. So whether you wish to run *The Red Rose*, the *Torbay* or the *Scotsman*, or any of the other titled trains now possible, you have ready to hand the means of doing it.

We must have another talk about the arrangement, etc., of the nameboards and titles later on, as there are many interesting things to be observed about them.



"Bristol Castle", with engine Headboard attached to the front handrail, proudly heads "The Bristolian" as it speeds along the Hornby-Dublo main line.

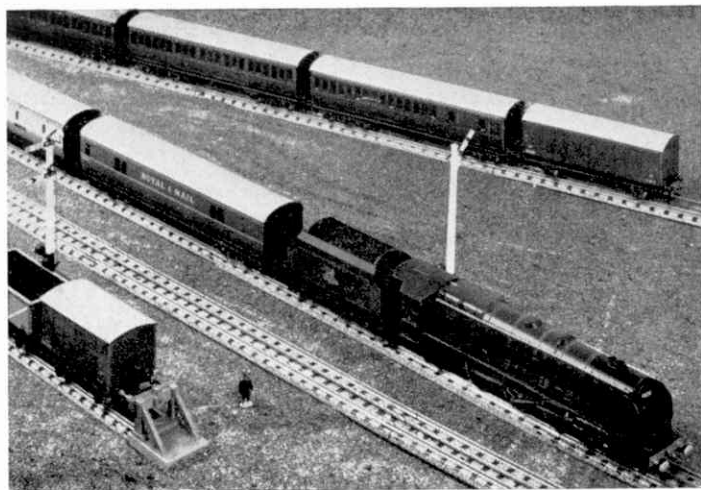

A T.P.O. Van forms an important part of the load behind 'Duchess of Montrose'. Much mail traffic is handled on Hornby-Dublo railways nowadays.

Mail and Van Trains

IT is some little time since these pages featured the Hornby-Dublo T.P.O. Mail Van and its uses. The amount of postal traffic in miniature on Hornby-Dublo Railways must now be tremendous, and this is quite in accordance with real practice, in which postal services are widespread and on a scale larger than most of us realise.

Practised Hornby-Dublo T.P.O. operators will not need reminding of the various do's and don'ts that ensure success in working the T.P.O. Van and its necessary Lineside Apparatus for the exchange of mailbags. The various "rules" all appear in the instruction leaflet that goes out with every T.P.O., but beginners are sometimes apt to neglect these in the excitement of starting up a Postal service in miniature on their layout.

So don't forget that the T.P.O. Lineside Apparatus, which incorporates a full-length rail, must be separated from any curved section of track by the length of at least a Straight Half Rail at each end. This gives the Van a chance to maintain a good settled straight course and makes for certainty in the operation of the mail exchange.

Another important point is that the power supply for working the T.P.O. MUST

be separate from any used for train driving. Sometimes this is overlooked and puzzled owners write to ask why their T.P.O. Mail Van does not work correctly. Too high a speed also can upset things, for you must give the apparatus time to carry out its tasks correctly. After all, real mail trains travel at a good steady pace, not at the tear-away speeds sometimes imagined.

No oil is necessary on any part of the Hornby-Dublo mail exchange apparatus, but the T.P.O. Van itself must be in free running condition. It is a heavy vehicle, because of the mechanism it contains, and in order to make sure that its inclusion in a train does not tend to overload the engine, you should see that the axle bearings are nicely lubricated, the bogies themselves free, and the wheels kept clean. Otherwise you will get "woolly" running and poor contact, resulting in indifferent performance.

Finally, do not forget that the mailbags themselves must be kept clean, polished in fact, so that they move easily throughout the exchange operation. They are apt to get "grubby" as the result of handling and they can pick up dust from the receiving "net" of the Lineside Apparatus, particularly if the railway is a permanent one and is not covered over when out of use. One Australian enthusiast writes that he

A special consignment travels in the long wheelbase Ventilated Van. On real railways short trains of this nature run for various purposes, one example being shown in the picture below.

has had his mailbags chrome-plated, but this is perhaps going a little further than is absolutely necessary. Just keep these parts really clean and all will be well.

Many other interesting trains include vans, for parcels and other traffic, and sometimes these exhibit a remarkable collection of rolling stock in their formation. Some trains of this kind are regularly booked, but there are many instances of odd vans that are worked from point to point attached to passenger trains. Regular transits of this kind are often called by the staff by names associated either with the particular goods conveyed or with the route involved, or even with the destination. Titles for express freight trains are not unknown, as we have seen in earlier talks, but among the types of trains we are now considering there are such titles as the *Crewe Parcels*, or simply, *The Johnson's*, the latter being the name of the firm despatching the traffic.

In miniature it adds considerably to the interest of operations if you produce one or two workings of this kind in your operating programme. You can do it easily. Just look at the two pictures on this page, one showing a Van for parcels traffic in Hornby-Dublo and the other the same thing

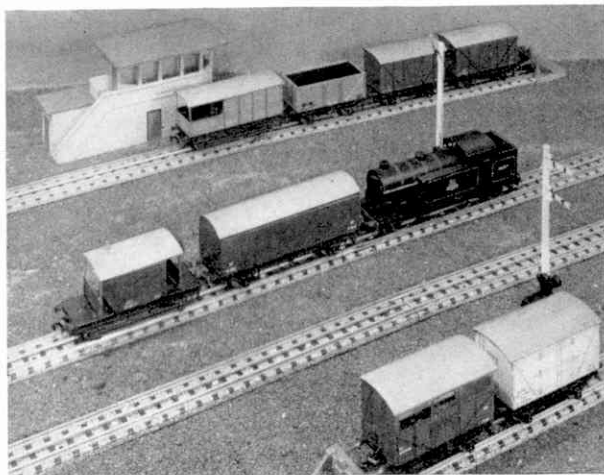

in actual practice. Odd little trains like the one in the lower picture can have other purposes. For instance, cattle vans or tank wagons may be found in similar small formations of perhaps one or two vehicles. Horseboxes also travel in ones and twos at times, because of the special requirements of their "passengers."

Apart from the passage of the traffic in the loaded direction there have to be corresponding movements of empty vehicles. These may be regular, as they often are in real practice, or they may simply take place as required, when they may provide some operating problems. So you can have plenty of variety, whether the traffic in miniature is based on something you have seen, or know about, or whether it has simply been conjured up in your imagination to suit your own railway.



A van with parcels for Waterloo is brought into Evercreech Junction. This is the type of working represented in Hornby-Dublo in the upper picture on this page. Photograph by R. E. Toop.

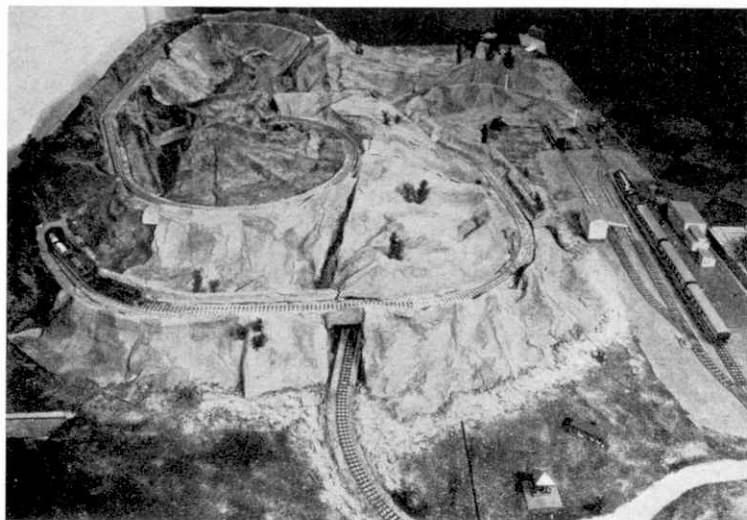

A Hornby-Dublo layout that represents the Raurimu Spiral of New Zealand Railways. It was constructed by T. Hope, New Zealand.

Hornby-Dublo Spiral

By "Layout Man"

RAILWAY spirals, in Switzerland, Canada and elsewhere, are fascinating means of climbing formidable heights or descending from them. This is especially the case when parts of the spiral tracks are in tunnels in mountain sides, as in famous examples in the two countries I have mentioned. Now we have a splendid set of spirals in Hornby-Dublo on the layout of T. Hope, of Taumarunui, a New Zealand enthusiast. It is seen in the picture above, and represents Raurimu Spiral, on the New Zealand line between Auckland and Wellington.

The extent of the base required for the line has meant that the board has had to be built up in two sections, but the railway on it and the countryside that it traverses are continuous. Although standard Hornby-Dublo stock and equipment of British type is used, the layout has been designed to reproduce on a small scale actual conditions on the Raurimu Spiral, but there is one difference. This is that the real railway from Auckland to Wellington, having negotiated a rise of more than 400 ft. in four miles by means of the spiral section after Raurimu, continues on its way, but the miniature system is laid out to afford continuous running, so that a train leaving

the miniature *Raurimu* station ultimately returns there.

The track of course includes a good many curved sections of rail, doubling back from the station and climbing continuously over further curves to complete a spiral turn, so that the track passes over itself immediately before the summit point is reached. After this a corresponding down grade brings the railway through a long tunnel that effectively screens this part of the line from the spiral section, until it passes under the ascending section, as shown in the illustration above. Then it doubles back to re-enter *Raurimu*. Besides the long tunnel already mentioned there are on the actual spiral section two shorter ones, each with realistically-modelled entrances. In fact, as can be seen above the general nature of the terrain is well in keeping with the character of the system.

The Hornby-Dublo Locomotives in use include a Duchess and an A4 Pacific and one of the popular and powerful 2-6-4 Tanks. The loads have to be restricted on the gradients, but this is in keeping with the conditions over the real section that is represented, where the gradients mean that even the powerful New Zealand Railways 4-8-4s are limited to loads of 320 tons.



Club and Branch News



WITH THE SECRETARY

THE INDOOR SEASON

In Great Britain this month brings us to the end of British Summer Time, and almost overnight we find ourselves thrust once more into the long period of dark evenings and indoor activities that will last until Spring is here again. Experienced Clubs and Branches will have already begun their pre-arranged programme of indoor meetings drawn up for the first of the Winter Sessions, and in which Meccano model-building or Hornby — or Hornby-Dublo—Train operations are the "backbone". New Clubs and Branches will, no doubt, follow the same pattern, and will learn by experiment what additional hobbies and recreations are popular with their members as occasional diversions from the main activity. I wish all Clubs and Branches, new or long-established, a very full and profitable indoor season.

CLUB NOTES

MILE END (PORTSMOUTH) M.C.—The recent Open Day display, in which the associated H.R.C. Branch co-operated, was most successful and about 300 people visited it. A profit of about £6 went to the Joint Fund. Sixteen new members were enrolled, and in order to provide adequate facilities for them the Dinky Toys and Branch layouts are being extended. A graph has been prepared, indicating the various activities of the Club and Branch. *Secretary:* Mr. A. J. Nicholson, 213 Sultan Road, Buckland, Portsmouth.

AUSTRALIA

MAYLANDS M.C.—Model-building has been stimulated by the Club being invited to exhibit at the Hobbies Council's big Exhibition. The bookbinding meetings continue to make good progress, and the Table Tennis tournaments have reached an exciting stage. In June fine weather at week-ends enabled excellent cycle runs to be organised, but only two outings were possible in July owing to severe storms and the resultant flooding of the roads. One trip was to the camp site at Brumby Flats, where a new pump was tried out on the camp bore. The first Film Evening for some time was attended by the Leader and 40 members, who visited the Grand Theatre, Perth, to see the film *The Battle of the River Plate*—the father of one of the members was a gunner on H.M.S. *Exeter* during the actual battle. A competition for the design of a Club Badge has been held, but no entry was outstanding enough to be adopted. *Secretary:* T. Down, 31 Drummond St., Bedford Park, W. Australia.

SOUTH AFRICA

CAPE PENINSULA M.C.—Most of the recent meetings have been spent in model-building. The Merit Award Cup, awarded to the member who has made the most progress over the year, was presented to Tatchell Venn, who also won the first prize in the senior section of the annual Winter model-building competition. The subject this year was *In the Dockyard*, and Venn's model represented a dockside. C. Cohen won second place with a fine model of a 50-ton dockside crane. Other good, relevant models included an iron ore unloader, ship's compass, car ferry, and a hammerhead crane. *Secretary:* T. Venn, "Ranfurly", Roodebloem Road, University Estate, Cape Town, South Africa.

BRANCH NEWS

SLOUGH AND WINDSOR.—Membership rose considerably after a short article about the Branch appeared in the local press. Meetings are held each Saturday afternoon at the Club Room, Community Centre, Farnham Road, Slough, one hour being spent on Meccano model-building, one hour on Hornby layout operations, and the final hour on sports such as swimming, or in train spotting. *Secretary:* K. Glover, 5 Elliman Avenue, Slough, Bucks.

AVIARY (LEEDS)—Meetings have been held fortnightly during the Summer, with Cricket as one of the outdoor activities. A photographic competition has been organised, in which photographs taken since the opening date of the contest have an advantage over older prints submitted. Indoor meetings have been on the two-group plan, one group having a railway modelling evening, and the other having a Quiz night. The latter takes the form of a talk on some interesting railway or other subject, followed by questions and



An interesting Meccano windmill built by two members of the Newtown School, Waterford (Eire) M.C., one of whom poses beside it to give an idea of its height.

answers about it. On one occasion a Mr. Myers, the Chairman's father and an old sailor, gave a talk on his life in sailing ships; and on another evening the speaker dealt with the making of pottery, illustrating his talk with a film and examples of his own handiwork. A Treasure Hunt is being planned. *Under-Secretary:* Ian M. Poultney, 1 Arley Grove, Leeds 12, Yorks.

KIDDERMINSTER MODEL CLUB.—The Branch now have two excellent tables which, when placed together, provide an area 8 ft. sq., on which to put down the Branch layout. Places of interest visited have included Stourport-upon-Severn Power Station and Kidderminster locomotive shed (8SD). A film show, with three films loaned by the British Transport Commission, has been arranged. *Joint Secretary:* A. J. Potter, 35 Woodfield Crescent, Kidderminster, Worcs.

SUPER DISCOUNT APPROVALS!

Our Bargain Discount QE Approvals really are SUPER! They contain QE issues in singles and sets and a host of other modern issues in first-class selections, 1d. to 6d. per stamp. Br. Cols. only or Br. Cols. and Foreign Mixed available. We pay outward postage. Selections sent only in U.K. and Eire. Send today. You'll not be disappointed!

THE BIRKDALE STAMP CO.
104 Liverpool Rd., Southport, Lancs.

Postal Business Only
(NO CALLERS)

BARGAIN for stamp
Collectors
Set of 4 Great Britain Queen
high values, 2/6, 5/-, 10/- & 1/-
stamps, for only 2/-!

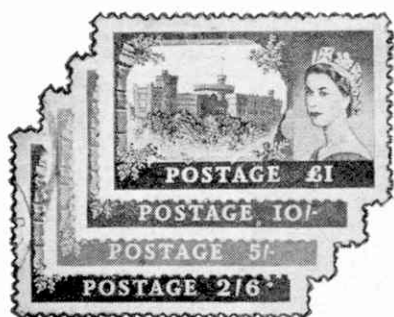

These beautiful Stamps are catalogued 22/9, face value 37/6, normally sell at 17/6. Send only 2/- and ask to see our Approvals (No need to buy anything).

PHILATELIC SERVICES (Dept. M.M.36)
Eastrington, Goole, Yorks.

SERIOUS COLLECTORS SHOULD SEND A POSTCARD FOR FIRST-CLASS APPROVALS SELECTION STATING CHIEF INTERESTS.
H. B. LANG
BURNBANK—MAUCHLINE—AYRSHIRE

BRITISH Colonial, Foreign Spacefillers, 15 a 1d. Pictorials, Commemoratives, Colonials, Foreign, 1/2d., 1d. Postcard secures hundreds approvals.
PILGRIM
Priory View Road, Moordown, Bournemouth



WRIGHT'S STAMP SHOP (M.18), Canterbury Ltd. Canterbury, Kent

For other Stamp Advertisements see also pages 502 and xxii

PICTURE CARDS

We offer complete sets in clean condition.
50 Planes 2/9 50 Trains 2/9 50 Animals 2/9
45 Birds 2/9 50 'Space' 2/9 50 Footballers 2/9
50 Ships 2/9 50 Fishes 2/9
50 Cars 2/9 50 Cricket 2/9 Any 4 for 10/-
100 different cards 3/- post free.
ALBUMS to hold 200 cards 2/6 post free.
Send 6d. for CATALOGUE of 1,500 different series
FREE MATCHBOX LABEL



This scarce SIAMESE label sent FREE to all those sending 3d. and requesting our MATCHBOX LABEL APPROVALS

E.H.W. Ltd. (Dept. M)
12 SICILIAN AVENUE, LONDON W.C.1

100 Different Stamps FREE!

Plus Super Perforation Gauge to all applicants asking to see my famous 1/2d. upwards Approvals. British Colonial or Foreign. Don't delay, write today enclosing 3d. stamp for postage.

C. T. BUSH (MM9),
53 Newlyn Way, Parkstone, Poole, DORSET

50 PICTORIAL STAMPS FREE

This packet of stamps is given absolutely FREE to all genuine applicants for my superior used British Colonial Approvals enclosing 4 1/2d. in stamps for postage. Overseas Applications Invited.

D. L. ARCHER (M),
2 LITCHFIELD WAY, BROXBOURNE, HERTS.

110 DIFFERENT STAMPS FREE!

Foreign and Colonial including Pictorials, absolutely Free to applicants requesting my famous discount approvals, enclosing 3d. for postage.

H. BANKS, 62 AVONLEA ROAD, SALE, CHESHIRE

FREE! PICTORIAL PARCEL
with Approvals 3d. stamp please.
ALCOCK, 74 Tynparc Rd., Rhiwbina, CARDIFF

10 ZOO - FREE!

ALL MINT - INC. ILLUS.

REQUEST QUALITY
APPROVALS or PRICE 1/3
WITHOUT APPROVALS

Applicants must send 3d. for Postage (Abroad 1/- extra for Regd.). Adult collectors catered for. If you wish you may join "THE CODE STAMP CLUB" Sub. 1/- . Approvals sent monthly. (Postal Sec. Est. 1897). We aim to please.



Stamp Collectors' Corner

By F. E. Metcalfe

IRELAND

I receive almost as many letters about stamps from across the Irish Sea as from England, so I think that can be taken as a good pointer to the present day popularity in Ireland of stamp collecting, whatever it may have been in the past. Among Irish collectors, too, there are a large percentage who really understand philately, and are not merely "stickers-in of stamps." Indeed they had to be keen on stamps, to put up with the way their stamps were exploited when their first overprints appeared in 1922!

When the country became the Irish Free State, as she had none of her own stamps ready, those current in Britain were overprinted, and until the first Irish definitive set appeared late in 1922 it was fun and games for all. The various overprints were exploited to such a degree that most collectors got heartily sick of the whole lot, with the result that even now they remain in the philatelic doldrums.

I propose to say very little about these stamps. If there are any philatelists who wish to study them, they will find them fully listed in Gibbons Part 1 catalogue. I am writing rather for the junior collector, and to hold forth about the various Irish overprintings would only defeat my purpose, for I would be sure to frighten most beginners away.

Incidentally, I was very glad to see that though Ireland is no longer in the Commonwealth, Gibbons have decided once more to list all Irish stamps in their Catalogue Part 1. As they say, this step has no political significance; it has just been taken for the convenience of collectors. It was exactly for the same reason that the stamps were listed in the Commonwealth Catalogue, and in the latest "QEII" section, which lists all the commemorative stamps that have been issued since 1953, the definitive set of 1922 has also been included, in the present watermark of course. This set is still current and widely collected, not only for the stamps themselves, but also for postmarks.

This collecting of Irish postmarks is very popular, for it can be carried on quite inexpensively and by almost anyone. Recently a collection that actually contained

fifty thousand was sold in London. I suppose if I could afford to retire, I would probably do so in Ireland, somewhere on the West Coast. As the next best thing, I try to take as many holidays there as possible, and as I have travelled round Ireland a good bit, I have gathered a few nice postmarks myself. I treasure them very much.

As is to be expected, Irish stamps are among the most popular of all in the U.S.A., and some of the finest collections are to be found there. There are some very fine ones also in Britain, but it is not about these big and expensive conglomerations about which I want to write. One can form a collection of considerable interest for very little money, and in this connection I will let you into a secret.

Ireland started to issue special stamps in 1929. The first set was of three values, to commemorate Catholic Emancipation. Daniel O'Connell was shown in all three of the stamps. The next special issue came in 1930, to mark the completion of the Shannon Hydro-Electric Scheme. After that, further commemorative stamps were issued at fairly regular intervals, and altogether these make a very nice show, if well mounted and well written up.

That is all very well, young collectors may say, but as some of those stamps were issued many years ago, will they not be too costly for us? Not a bit of it, for here is the promised secret. Believe it or not, with very few exceptions these stamps can be bought at face value from the Philatelic Bureau, G.P.O., Dublin, by simply writing for them, enclosing their cost and of course return postage.

Now just get out your catalogue, and look at all those interesting stamps that Ireland has issued, and realise that all they need cost you is their face value. Apparently the Irish Post Office makes a printing of a certain quantity, sends out to the various post offices what they order, and then places the

balance in the Dublin Philatelic Bureau, where they remain until all are sold out.

If you order the definite set, you should stipulate that you want the 1d. and 1/- values in the "Sword of Light" design. Otherwise you will get the two stamps issued in 1944 to mark the tercentenary of the death of Brother Michael O'Clery, for these stamps replaced on general sale the "Sword of Light" pair.

Some of the earlier commemoratives were not overwhelmingly attractive, but latterly Eire has produced some real beauties. One of these was the Commodore Barry issue of 1956, and I got quite a thrill last September when I was able to see the statue depicted on the stamp, which is on the sea front at Wexford. I didn't see it very well, for it was raining very heavily.

I think that my favourite Irish stamp is the 1952 Thomas Moore issue. Be sure and get one of these and when you do, just examine the eyeglass held by Moore in his right hand. If you have a magnifying glass you

(Continued on page 504)



BARGAIN FOR STAMP COLLECTORS

114 Different STAMPS
INCLUDING
SPUTNIK!
Plus 88 FLAGS



THE GREATEST STAMP BARGAIN EVER OFFERED

GERMANY-SPUTNIK, first "Space Stamp" in history. MONACO—Grace Kelly Wedding. CUBA—Cigar Set. NEW KINGDOM OF MOROCCO—King Mohammed Provisional. JAPAN—Oriental Birds (3). RED CHINA—Liberation (2). UNIQUE SE-TENANT—2 different Roumanian stamps in a genuine joined pair. Grand total 114 different genuine stamps from all over the world. PLUS 88 DIFFERENT "FLAGS OF THE WORLD". A fascinating and unusual extra to dress up the pages of your album.

PLUS MIDGET ENCYCLOPAEDIA OF STAMPS. STAMP DICTIONARY & IDENTIFIER. Tells you everything you'll want to know to enjoy the hobby and become an expert.

FREE! BOY SCOUT JAMBOREE SHEET.—An unusual tribute to the 1957 Jamboree.

EVERYTHING FOR JUST 1/- TO INTRODUCE our BARGAIN APPROVALS
Send 1/- today. Ask for Lot MC36

BROADWAY APPROVALS
486 OLD KENT ROAD, LONDON S.E.1.

F R E E !**CATALOGUE VALUE 5/-**

TO ALL APPLICANTS FOR OUR
BRITISH COLONIAL APPROVALS
ENCLOSING 3d. STAMP.

BARGAIN OFFER
BARBADOS Q.E.

\$2.40

BLACK FINE USED
Cat. 20/- Price 10/-

R. J. SMITH & SON

81 Redbreast Road, Bournemouth

100 STAMPS OF THE WORLD — FREE

An outstanding offer to approval applicants. Postage essential. Not abroad.

YULWONTMOR STAMPS,
(Dept. M), 29 Layton Avenue, Mansfield, Notts.

6 BRITISH GUIANA 6 FREE

Send 3d. stamp for approvals priced from
 $\frac{1}{2}$ d. each

MAINLY BRITISH COLONIALS

G. C. ANSON

84 Shirley Way, Shirley, Croydon, Surrey

Double Gift Offer!

NEW ISSUES-PICTORIALS-GIANT STAMPS are all in my "Tip-Top" **DISCOUNT APPROVALS** (6d. in 1/- discount). All customers receive a **FREE PACKET OF COLONIAL PICTORIALS** and every book contains an **EXTRA GIFT**. 3d. postage appreciated.

M. THEOBALD (110)

4 Sipson Road, West Drayton, Middlesex

FREE—STAMPS CATALOGUE 5/-
to applicants for $\frac{1}{2}$ d. approvals.

COX, 17 STONELEIGH PARK ROAD, EWELL

!CYPRUS! Nine different FREE to new applicants for our
40% DISCOUNT COLONIAL APPROVALS 3d. stamp
Fletcher (C69), Woodlands, Church Road, Bristol 9

SPECIAL. To all approval applicants this month.
FREE! K.G. VI VICTORY SET MINT. 3d. Postage.
A. CUNNINGHAM (Dept. MM), 36 Doonfoot Road, Ayr.
For other Stamp Advertisements see also pages 500 and xxii

All Different PACKETS All Different

World 500 5/-; 1,000 10/-; 2,000 23/-; 3,000 40/-;
Brit. Empire 200 3/6; 300 6/9; 500 14/9; 1,000 44/-
25 Zanzibar 7/3 25 S.W.A. 2/9 25 Barbados 5/-
25 Eritrea 4/6 100 Turkey 3/8 20 Triangles 2/4
SETS.—PERU New Postal Centenary Set of 5... 11d.
MONACO 1956 Wedding, 5 all large mint stamps... 1/9
RUSSIA 1953 Volga Don Canal, 3 beautiful used... 1/-

Overseas orders welcome

Postage 4d. **H. V. JOHNSON & CO.** Lists Free
78 Dale Road Wickerley ROTHERHAM

FREE! ZOOLOGICAL NEW ISSUE PACKET

A fine selection of new and recent issues including
Somaland Wild Animal Short Set, Poland "Fishes"
Short Set, and others. Most attractive lot offered
quite free to introduce our service to new collectors.

Just send 3d. for postage. Write today to:

CAPTAIN M. CAMPBELL & CO. (Dept. MM)
58 High Street, WATFORD, Herts.

6 GIANT GRETE (Rpr.) FREE TO everyone ordering one of these PACKETS

10 diff.		50 diff.		200 diff.	
Afghanistan 3/6	Peru .3/-	Belgium .3/6			
Saudi Arabia 2/-	Australia .2/-	Austria .5/-			
25 diff.	S. Africa .2/6	Italy .5/-			
Israel .. 4/-	100 diff.	500 diff.			
Lebanon .. 2/-	Hungary .2/-	China .. 10/-			
Hong Kong .. 3/9	Russia .. 3/9	Germany 10/-			

With parents' permission please

Postage 3d. extra. C.W.O. LIST FREE.

Battstamps (C), 16 Kidderminster Road, Croydon, Surrey
MODERN UNSORTED LOTS ON PAPER—British Empire
1 lb. 27/6, $\frac{1}{2}$ lb. 14/-, 4 oz. 7/9, World-wide lot 1 lb. 22/6,
 $\frac{1}{2}$ lb. 12/-, 4 oz. 6/6, Gt. Britain 1 lb. 7/-, $\frac{1}{2}$ lb. 4/3. Lots
per 4 oz.: U.S.A. 5/6, Europe 7/6, Eire 4/3 (abd. ext.)
A. DAVIES (M10), 3 Manor Road, Wroxall, I.O.W.

For other Stamp Advertisements see also pages 500 and xxii

Stamp Gossip

LAKES VICTORIA AND TANGANYIKA

Perhaps one of the most popular British Commonwealth issues that will be made this year is the pair of stamps from Kenya, Uganda and Tanganyika to commemorate the discovery, by Europeans, of Lakes Victoria and Tanganyika by Captain Burton and Captain Speke. The stamps (40c. and 1/30c.) are both of the design of the one illustrated, and while they could have been a bit more original, they are certain to be popular not only with British Commonwealth collectors, but also with those who go in for thematics.



I have not room to quote at length the excerpts from the journals of the two explorers printed in the Crown Agents' Stamp Bulletin, for they make interesting reading. For instance, Captain Burton wrote "On the 13th February 1858, we resumed our travel through screens of lofty grass, which thinned out into a straggling forest. Later we halted for a few minutes upon the summit. What is that streak of light which lies below? Somewhat prematurely I began to lament the folly in having risked life for so poor a prize. Advancing, however, a few yards, the whole scene suddenly burst into my view, filling me with admiration, wonder and delight." Thus Lake Tanganyika was found.

What thrills there were, in the old days, for the adventurous. We have to be satisfied with stamps as our share of those thrills.

ATHLETICS

The season for summer sports is now over, but this does not prevent some postal administrations from bringing out sports stamps *ad lib.* When these are as attractive as the Japanese set issued by the Japanese Post Office to commemorate the 3rd Asian Games we cannot grumble; in fact, a lot of us are pleased.



The face value of Japanese issues is generally moderate, and the stamps are issued in reasonable quantities, so I suppose this Asian Games set will feature in thousands of collections. It is certainly colourful.



PERSIAN PERFORATION

Some little time ago I received letters from two readers about the Persian stamp illustrated on this page.

Last November the International Weight Lifting Championships were held in Iran and, believe it or not, the figure on the stamp

that rather resembles the Atomium at the Brussels Exhibition is nothing more than one of those big beefy weight lifters, who look as though they could lift not just pounds, but tons. It is not the design that interests me, but the perforation, for whereas there are great big teeth along the top and bottom, the side perforations are very fine. The actual measurements are $11 \times 14\frac{1}{2}$, a unique combination.

THAT OVERHEAD

Austria is noted for its beautifully engraved stamps and attractive designs, which I am afraid is more than we can claim for many of our own British stamps. One Austrian stamp is illustrated here. Take away the wording from it, and electric railway enthusiasts, whether from Liverpool or not, could be excused for thinking that the picture showed the Liverpool Overhead Railway, which at the moment of writing is being pulled down.

The *M.M.* goes all over the world, so I don't think that this will be considered too parochial a subject.

THE "REGIONALS"

By the time these lines appear in print, I suppose that the stamps, with altered designs, for use in Scotland, Wales, etc., will be on sale. Here are the values, for those who missed the newspaper announcements. Northern Ireland, Scotland and Wales are each having the 3d., 6d. and 1/3d. stamps, while the Channel Islands and Isle of Man will have the 3d. only. A nice copy of each—make sure they have been used in the right region, for they are valid for postage all over the U.K.—will make a nice page in your album. Unless some worthwhile varieties are found that is about all one can say about them.



TIP OF THE MONTH

This month I have paid a long outstanding debt by dealing on another page with the stamps of Eire. Most of the stamps issued since 1937 are still obtainable at the Dublin Bureau, but there is one quite modest little stamp, the 3d. air mail, that is not available. I say modest, because I saw one recently offered at 4d. by a dealer who apparently did not know that the stamp was obsolete. Now I think all the Irish air set should be bought, but make sure that you get both the 1d. and the 3d. values. The former is still on sale, or was until quite recently, while the 3d. can be picked up for a few coppers, but once it is generally known that the latter is obsolete, a copy may soon cost shillings where it now costs pence.

Machines that Learn for Themselves—*(Continued from page 461)*

also be used to recognise shapes, rather like the little bird that crouches when another bird flies over it. Instead of the bird's eye, there is a bank of photocells feeding the computer. These are to be seen on the left of the picture on page 460. A T-shaped piece of cardboard throws a shadow on them and, at the same time, a sign reading "Duck" is lighted. After some "training" like this the machine learns to "duck" each time the shadow falls on it. It can also do some of the tricks that Pavlov's dogs could do—tell it there is a bone and the word "beg" lights up!

The Conditional Probability Computer is the first of these new machines that think for themselves. One day they may be used to control whole factories and offices, and scientists are quite excited by the possibilities they open. Not for the first time, Meccano is in right at the beginning of a piece of important research.

Space Notes—(Continued from page 475)**Tape Recorders are Missiles**

When missiles are flight-tested the primary aim is to obtain as much information from the test as possible. Usually instrument readings are sent by radio back to a ground station, where they are recorded and analysed. It is now common practice also to install a tape recorder in test missiles to record important information in case the radio telemetry equipment fails.

The Northam MR-1 missile tape recorder, illustrated on page 475, not only makes the smallest commercial tape recorder look like a giant, but also works in the most exacting conditions. It will record eight separate sets of information and will do so under an acceleration of 500 g. and at any temperature from just above freezing to 60 deg. C. It is armoured to withstand landing shocks, but complete with armour and batteries it only weighs four and a half pounds.

Stamp Collectors' Corner—(Continued from page 501)

will see that the engraver—a master craftsman whoever he is—has indicated the magnification of the cloth of his coat through the glass, a wonderful touch.

I would like to go on writing about Irish stamps for hours, and I could do. When I have finished these notes, the very first thing I will do will be to get out my own modest Irish collection, for I have a couple of nice varieties to mount. But there is just one thing I must say in conclusion. Latterly some of the portrait stamps have been reduced in size in comparison with the earlier ones. I do wish the authorities would go back to the measurements of the Tom Moore and Robert Emmett issues. The stamps commemorative of John Redmond and Thomas O'Críomhain do not get a chance to show how finely they are engraved.

Lighting up Niagara—(Continued from page 488)

Falls are flooded with the most powerful and colourful light ever seen there. The 20 weatherproof G.E.C. projectors do not use more power than the 24 floodlights previously used, but they provide 10 times the amount of brightness and light up a larger area of the Falls and the neighbourhood.

The projectors make use of carbon arc lamps of high current density. In front of each is an aluminium housing, 8 ft. high, 4 ft. wide and 2 ft. deep, that has toughened glass sheets, each a yard in diameter and $\frac{1}{2}$ in. in thickness, framed in its front and rear faces. These allow the floodlight beam to pass straight through the unit. The housing also has five vertical channels on each side, so that five colour frames, each 37 in. square, can be slid into position across the beam.

It is these frames that carry the colour mediums that allow the wonderfully varied displays of colour lighting that visitors now see. The selection of sequences is made by an operator seated at a remote control console,

where he has a good view of the Falls. Used singly, or in combinations of two or three, the five specially chosen filters in each colour control unit permit 15 hues to be projected in vertical or horizontal bands, providing a truly fascinating changing spectacle.

A British Moon Rocket Plan—*(Continued from page 464)*

of putting an instrument package gently on to the Moon surface.

Such a rocket must have a guidance system, and would probably use photo-electric cells, acted on by the sunlit face of the Moon and a complex system of altitude control. Another necessity will be a braking rocket motor, to reduce its speed so that it can land gently on its landing legs.

From this to the landing of the manned vehicles would be a further step, and various ideas for making such efforts possible have already been worked out in theory by members of the British Interplanetary Society. Such a vehicle of course would have to return to Earth, for it could scarcely be expected that pioneer human beings could continue to live on the Moon for long periods. That is one reason why the vehicle would have landing legs, as shown in the pictures of it, and reverse thrust braking to ensure that it would land on the Moon in an upright position, in readiness for launching through space again back to Earth.

Does this appear fanciful? Well, time alone will tell.

The VertiVeyor Competition—(Continued from page 491)

of The VertiVeyor, and will give competitors all the guidance they need in building their models.

Competitors may use any quantity of Meccano parts they choose in building their models and it is not essential to reproduce the constructional details of The VertiVeyor exactly. It is only necessary that models should reproduce the main structural features of the machine, and be capable of carrying out the essential operations.

How entries are to be prepared and sent in will be explained next month.

"ABC Civil Aircraft Recognition"

By John W. R. Taylor

(Ian Allan, 2/6)

This is the first edition in the new, larger format adopted for these aircraft booklets, and it shows that in the three years since the previous issue much has happened on the world airways. The aircraft illustrated and summarised in this new edition include many new types and, in fact, every important civil aircraft likely to be seen in Great Britain. Commercial passenger and freight aircraft are dealt with in the first part of the book each type being illustrated with a silhouette as well as a photograph. Details given for the major types include notes on their development and service, main dimensions, type of power unit, and range, speed, etc. They are followed by 36 smaller types of aircraft, each with half-tone illustration, a brief descriptive paragraph and details of wing span, length, gross weight and range.

N.Z. Health Stamps

By a regrettable error the figures on the 1958 New Zealand Health Stamps were described in the September *M.M.* as a Boy Scout and a Girl Guide. They are, of course, a Boy of the Boys' Brigade and a Girl of the Girls' Life Brigade.

From Our Readers

This page is reserved for articles from our readers. Contributions not exceeding 500 words in length are invited on any subject of which the writer has special knowledge or experience. These should be written neatly on one side of the paper only, and should be accompanied if possible by original photographs for use as illustrations. Articles published will be paid for. Statements in articles submitted are accepted as being sent in good faith, but the Editor takes no responsibility for their accuracy.

The Kariba Dam

In the month following the appearance in the *M.M.* of the recent article on the Kariba Dam, I visited the site on a school tour. We flew up by chartered plane, and landed on the small airstrip there. We went to the site itself by bus, with a guide, and from the top of the hill, with the underground power station below, I took the photograph reproduced alongside. Unfortunately blasting was in progress and in consequence we were not allowed in the power station, or on the river banks.

The tanks in the right top corner of the picture are storage for cement, which is mechanically conveyed from them down to the site. Just below the cement storage there is a triple tank for the storage of sand that was brought from the south bank of the river by Blondin cable. In building the Dam great use is being made of the cableways described by this name.

My photograph was taken just after the cofferdam had been pumped clear of water and while the damage caused by the terrific flood earlier in

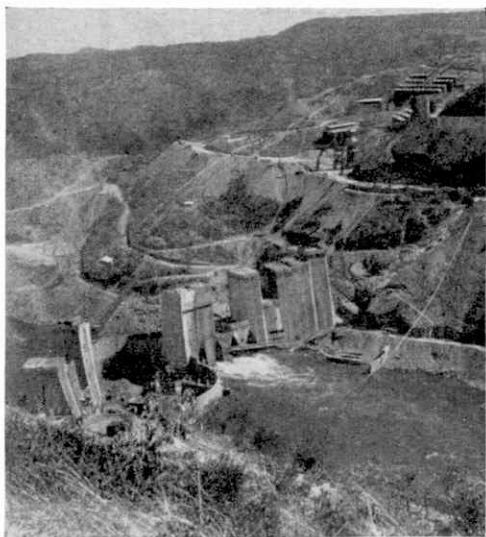

This picture shows the scene at the site of the Kariba Gorge Dam when it was visited by K. Greenway, Salisbury, Rhodesia, shortly after reading the article on the Dam in the June "M.M."

the year was still being repaired.

K. GREENWAY (Salisbury, S. Rhodesia).

A 1 h.p. Power Unit

While motoring in North Wales I came upon a narrow gauge track connecting a brickworks to a railway siding. Thinking it would make a good subject to model, I made further investigations, but could only find small trucks and no form of motive power.

The mystery of the lack of power was solved several weeks later, when passing the same place I saw the train winding its way across the fields—drawn by an 0-4-0 1 h.p. fine grey mare! I promptly photographed the scene, although I had to do this in a downpour of rain.

This is one "locomotive" readers will find difficult to reproduce, but any who wish to see the original will find it at Brymbo brickworks, half-way between Minera and Caergwrle, near Wrexham.

E. G. KAY (Chester)



An unusual form of engine power nowadays, even on a light railway. Photograph by E. G. Kay, Chester.



"Turn it on, Charlie!"

Fireside Fun

"I hear your sister is ill, Bobby," remarked a neighbour. "Nothing serious, I hope?"
 "Not specially," answered Bobby. "We were just playin' a game seein' who could lean the furthest out of the window, and she won."

* * * *

A lawyer had just won his first case, and his client, a man acquitted of a burglary charge, came over to congratulate him.

"Well," he wound up, "thanks a lot. I'll drop in on you some time."

"Fine," said the lawyer. "All I ask is that you make it in the daytime."

* * * *

Jake: "How's business?"
 Rastus: "Kindly remove your hat when you speak of it."

* * * *

Policeman: "Now, my man, what are you doing here?"
 Biologist: "Why . . . er . . . officer, I am looking for flora and fauna."

Policeman: "Move along, or I'll run you in—and your girl friends, too."

* * * *

A soap-box orator was warming to his subject. "Comrades," he said, "make me your leader and in all you do I'll be behind you."

* * * *

"What are you reading, Bobbie?"
 "I don't know."
 "But you're reading aloud."
 "Yes, but I'm not listening."

* * * *

"Why are you here again?" asked the prison chaplain.
 "Because of my belief," replied the burglar.
 "Your belief?"
 "I believed the policeman had gone."

"Where is the platform for the Manchester train, please?"

"Turn to the left and you'll be right."

"Don't be cheeky."

"Very well, then—turn to the right and you'll be left."

* * * *

BRAIN TEASERS

CODE PUZZLE

A simple code in which letters are represented by numbers gives 20 as the sum of the numbers representing a four-letter word. What is the word? A clue is that a bit of the whole thing is easy.

MAGIC SQUARE

Can you fill in the consonants in the following magic square?

```

E _ _ _
_ L _ _
_ _ R _
_ _ _ N
    
```

ANSWERS TO LAST MONTH'S PUZZLES

The solution to the Crossword on page 457 of the September *Meccano Magazine* is given in the accompanying diagram.

An Alphabetical Sum

The sum is a subtraction one, and the answer is £18 9s. 9d.

S	U	M		D	I	M
A		O	U	I		I
P	O	T		A	D	D
	R	H	Y	M	E	
S	E	E		O	W	L
K		R	A	N		E
Y	E	S		D	Y	E

BUCCANEER IS BACK!



“BUCCANEER”

one of the most popular and well loved of pre-war board games, is, as its name implies, a swashbuckling, adventurous game full of interest, fun, and ingenuity. Produced to Waddington's own standards of high quality, "Buccaneer" contains all the thrills of voyages to Treasure Island, and bringing home the treasure . . . including realistic looking diamonds, rubies, bars of gold, pearls, and barrels of rum!

Equally valuable cargoes can be captured on the High Seas . . . or you can trade for cargo at a foreign port.

FOR 2 TO 6 PLAYERS

25/-

(Including Purchase Tax)



Published by

JOHN WADDINGTON LIMITED

40 WAKEFIELD ROAD, LEEDS 10. Phone : Leeds 72244

London Office : 43 Hertford Street, W.1. Phone : GRO 8701

TRAINING FOR THE MERCHANT NAVY



THE H.M.S.

“CONWAY”

(CADETS ON ENTRY ARE ENROLLED CADETS R.N.R.)

Merchant Navy Training School

ON THE MENAI STRAITS

‘Conway’ course trains boys between 13½ and 16½ years for ultimate command in M.N. and R.N. Following the Conway motto “Quit ye

like Men, be Strong” — Sailing, Rowing, Swimming, Rugby Football are stressed. ‘Conway’ certificate counts as 1 year’s sea service when taking 2nd Mate’s examination. FEES: £261 p.a. (including uniform).

Illustrated Prospectus from:—

THE H.M.S. “CONWAY”, 18 Nautilus House, Rumford Place, Liverpool 3



RAILWAY MODELLER

The Magazine that Shows you How!

Develop your railway by adding easily made scenery. See the October Hobby Show Number.

2/-

FROM ALL GOOD MODELSHOPS & NEWSAGENTS

By Post 2/6 from:

PECOWAY, SEATON, DEVON

HEAR ALL CONTINENTS

WITH H.A.C. SHORT-WAVE RECEIVERS

Noted for over 18 years for . . .
S.W. Receivers and Kits of Quality.

Improved design with Denco coils:

One-Valve Kit, Model “C” Price 25/-
Two-Valve Kit, Model “E” Price 50/-

All kits complete with all main components and full instructions. (Valves extra if required, 8/- each.) Before ordering call and inspect a demonstration receiver, or send stamped, addressed envelope for descriptive catalogue.

“H.A.C.” SHORT-WAVE PRODUCTS
(Dept. M.M.), 11 Old Bond Street, London W.1.

CHEMISTRY APPARATUS



Send 3d. stamp for

LATEST
PRICE LIST

Booklets:
‘EXPERIMENTS’
1/2.

‘FORMULÆ’ 1/2.
‘HOME CHEMISTRY’
new edition 2/10

(Post Free)

BECK

(SCIENTIFIC DEPT. G), 60 High St.,
STOKE NEWINGTON, LONDON N.16

Where accuracy is essential ...

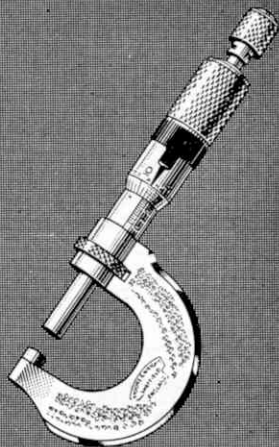
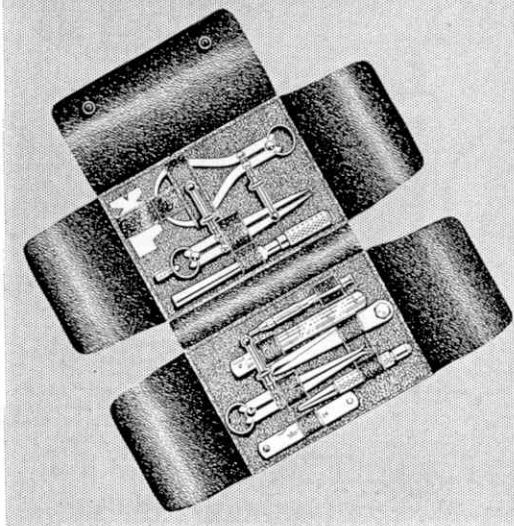

... and it is essential in **both** the buying **and** the using of tools ... remember that it pays to buy good tools, tools upon whose accuracy you can rely. **(M&W)** precision tools are made to British Standard Institute Specification—you can rely on them. If accurate measurement is your requirement **REMEMBER—**

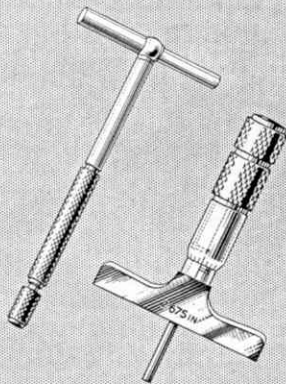

(M&W) Precision Tools
measure up to any job

SEND 10½d. IN STAMPS FOR A COPY OF OUR LATEST CATALOGUE, MENTIONING THIS JOURNAL.

MOORE & WRIGHT (Sheffield) LTD., NORTON LANE, SHEFFIELD 8.



Miniature Memento Cricket Bat

Bat 11½ in. long with the signatures of the New Zealand 1958 team on blade. Price 7/6. Carr. & Pk. 9d

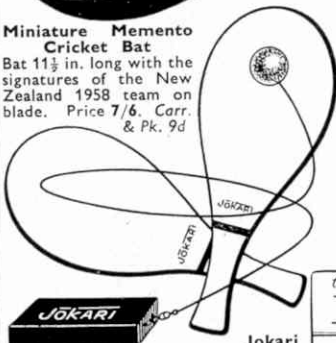

Jokari

The ball on elastic string tethered to the block is hit by each player in turn. You have to be fast and lively to play this game. Price 9/11. Carr. & Pk. 1/9

Tri-ang Inflatible Googly Ball. Dare your pals to catch this ball when you throw it to them. It goes all over the place. Price 6/11. Carr. and Pack. 1/-.
Miniature Ship in Bottle
 Little ship in bottle, only 1½ in. long. Price 8/11. Carr. and Pack. 7d.



Lots of fun from ...

Hamleys

Est'd. 1760

HAMLEY BROTHERS LTD.

The Finest Toyshop in the World



Match Boxes

Two new major matchbox diecast toys Walls Van—length 4 in. Tractor and Trailer—length 4 in. Price 2/6 Carr. & Pack. 6d.

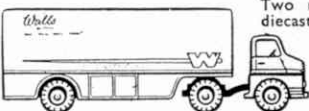

HAMLEY BROTHERS LTD.
 200-202 REGENT STREET, LONDON W.1.
 (Our only address) Telephone: Regent 3161

The FLUXITE way to Easy Soldering

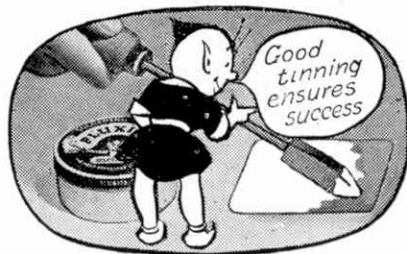

No. 8—JOINING TWO SURFACES (1)

When soldering a patch, or joining two pieces of metal together, both surfaces must be cleaned with emery and smeared with FLUXITE. Then apply the solder evenly and smoothly to give a good "tinning".

FLUXITE is the household word for a flux that is famous throughout the world for its absolute reliability. In factory, workshop and in the home FLUXITE has become indispensable. It has no equal. It has been the choice of Government works, leading manufacturers, engineers and mechanics for over 40 years.

FLUXITE
 SIMPLIFIES ALL SOLDERING

Fluxite Limited, Bermondsey St., London S.E.1
 G.M.58

Powerful Receivers and Amplifiers can now be made with

RADIO TRANSISTORS

No Mains required. A small Battery (4½ volts) will last weeks. Read all about it. For Notes on Transistors send 8d. stamps to address below.

READY BUILT AMPLIFIER 57/6

gives Loudspeaker results from Crystal Set—or we supply all parts to make your own Receivers, etc. We also specialise in the supply of Chemicals and Apparatus for Home or Works Laboratory.

Write for Chemicals and Apparatus List 4d. stamps. Both Lists 10d. stamps.

MORCO EXPERIMENTAL SUPPLIES

(Dept. M)

8 and 10 GRANVILLE STREET, SHEFFIELD 2

FOR PERFECT LUBRICATION
 THE
 "DERMIC"
 OILER



5/10

POST FREE

Manufactured by us specially for clean and accurate lubrication. If you own a Model Railway or Meccano Set the "DERMIC" will be invaluable. Packed in carton with full instructions.

GET ONE FROM YOUR LOCAL DEALER
 Price List of our "00" Railway Accessories, 6d. Post Free.

S. & B. PRODUCTIONS
 Portland Road, S. Norwood, London S.E.25



DON'T LET ACCIDENTS KEEP YOU OUT OF THE GAME

The woodman's axe—
a trusty tool
Is dangerous
if you play the fool



Exploring caves,
the clever scout
Lays a trail
to guide him out

Don't bird-watch
in a dangerous spot
Birds can fly
but you cannot!



—AND HERE'S ANOTHER GOOD TIP! Remind Mother that
chewing delicious Wrigley's Spearmint Chewing Gum
is naturally good for your teeth and won't fill you
up between meals. Ask her to buy you some today!



E211/8



GRAMMAR SCHOOL!

thanks to MERCER'S



Why not your child?
SIMPLIFIED POSTAL COURSES
are available to prepare children for

ELEVEN-PLUS EXAMINATIONS

- * FREE ATTAINMENT TESTS to all enquirers.
- * COURSES based upon results of these tests.
- * FULLY QUALIFIED TUTOR allocated by name to each Child.

FREE 24 PAGE GUIDE

MERCER'S UNIQUE GUARANTEE SPELLS SUCCESS

GENERAL CERTIFICATE OF EDUCATION

- FREE TEXT-BOOKS
- LOW FEES

Write NOW, giving full details to: The Registrar,

MERCER'S CORRESPONDENCE COLLEGE

(Dept. M.1), 69 Wimpole Street, London W.1.

Improve your shooting
with a

Diana AIR RIFLE

Wide range of
Rifle and Pistol
models at prices
from 24/6 to
£9/7/-.



★ SHOOTING TIPS

1. Do not point a gun at anyone—not even if it is unloaded.
2. Ensure all is clear before firing.
3. Aim by the sights, hold your breath and squeeze the trigger.
4. Always use Milbro Caledonian Waisted Slugs and Air Rifle Targets.

Obtainable from gunsmiths, sports dealers and ironmongers.

Ask to see our two Diana Air Pistols. If any difficulty, write direct to:

MILLARD BROTHERS LTD.

Makers of Milbro Products

Diana Works, Carfin, Lanarkshire

WORLD WIDE RADIO RECEPTION

FOR THE AMATEUR RADIO ENTHUSIAST
TUNE IN WITH THE
MALVYN SINGLE VALVE SHORT WAVE
COMMUNICATION RECEIVER

All-Dry Battery operated: Extremely low running costs:
Band Spread Tuning: Attractive Front Panel: Full
operating instructions included.
PRICE OF COMPLETE RECEIVER, 74/6 (Batteries and
Phones Extra). Post Free U.K. Money Back Guarantee.
Send S.A.E. to actual Manufacturers for Free Descriptive
Literature.

MALVYN ENGINEERING WORKS
Radio and Electronic Engineers

Tel.: Hertford 2264 7 Currie Street, HERTFORD

BOOKS:

A.B.C.s L.M.R., W.R., S.R., E.R.	..	each	2/6
60 Plans for Small Railways	2/6
Railways of Britain (Allan)	7/6
British Loco. or Train Postcards, assorted per 1/2 doz.	1/9

RAILWAY ACCESSORIES

Station Staff Sets	00	0
Seated Passengers	2/6	3/9
Ex-R.A.F. 16 Switch Boxes	7/6	7/6
Stone Tunnel Mouths, single line	5/5	—
Stone Tunnel Mouths, double line	6/8	—
Stone Retaining Wall, 8 1/2 in. long	3/11	3/11
Flexible Fencing, per 12 in.	1/2 1/2	—
Hedges, 11 1/2 in.	1/2	1/2
Assorted Trees	..	each	2/-	2/-
New "00", "TT" or "0" Railway Lists, each	6d.	..

POSTAGE EXTRA

TYLDESLEY & HOLBROOK (M.E.T.A.)
109 DEANS GATE, MANCHESTER 3

Make your own **REAL Musical Instruments** with kits from

FULL SIZE. Only a few simple tools are needed.

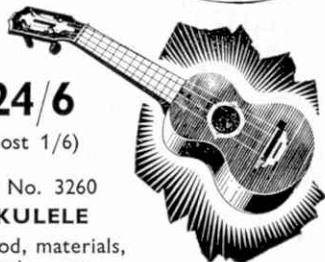

24/6

(post 1/6)

Kit No. 3260

UKULELE

All wood, materials, wire, string, etc.



59/11

(post free)

Kit No. 3209

GUITAR. All materials, full-size plan, six strings, etc.

Kits for making these fine toned, authentic instruments from Hobbies branches and stockists or by post (see coupon).

Ask for **FREE 20-page Booklet**

To **HOBBIES LTD.**, Dept. 961, Dereham, Norfolk

Please send free 20-page booklet and

Kit No.

Name

Address

Photographers!

Here's everything you need to
'PRINT-IT-YOURSELF'

This inexpensive outfit will set you up to print your own pictures—an absorbing hobby! The equipment includes: Printing Frame (3½ x 2½), packet of See-Thru Masks, 2 Plastic Forceps, 2 Clips, Thermometer, Measure, 2 ½-plate Dishes, Dark-room Lamp (battery operated), 1 packet of M-Q Developer, 1 packet of Developer 468, 1 tin of Acid Hypo Fixing Powder, 1 100-cc. Azol Developer.

ONLY £1.17.6

Complete

From Photographic
Dealers Everywhere



JOHNSONS
OF HENDON LTD

GAMAGES

1959 Edition MODEL BOOK



Just Arrived . . . 132 PAGES

OF FACTS, FIGURES & PHOTOS
OF TRAINS, BOATS, AIRCRAFT,
STEAM ENGINES, CARS, ETC.

FOR
ONLY

1/-

The latest and best edition — Get your Copy NOW!

Once again we have included a Special Plastic Kit Section with many of the kits that have just been released. All previous editions were acknowledged to be the most complete reference books available for trains, boats, aircraft, etc., etc. This is even better! *Post 6d. or 8d. on two*

SUPER RUBBER TYRED ROLLER SKATES

Exceptionally good quality with silent replaceable Rubber tyred ballbearing wheels, plated platform and lace-up leather toe-caps. For sizes 13 up to adult size 10. With laces and key.

BARGAIN PRICE

35/11

Post and Packing
2/6 if outside our
own extensive van
delivery area.



GAMAGES LATEST CONJURING CATALOGUE

68 PAGES

Every Magician—Beginner and Expert alike—will find "GAMAGIC" of absorbing interest. Exciting pages packed with details of Magical Effects, Jokes, Novelties and Puzzles, also Theatrical Props, Wigs, Stage and Make-up Puppets, etc.

Post 4d.

1/-



GAMAGES · HOLBORN · LONDON · E.C.1

HOL. 8484

NEW! PRACTICAL WAY of learning RADIO TELEVISION · ELECTRONICS

New—Up-to-date method of giving instruction in a wide range of technical subjects specially designed and arranged for self-study at home.

New—Experimental outfits and manuals sent on enrolment remain the student's property. Radio and Television courses, with which specially prepared components are supplied, lead, by easy stages, to the complete design and servicing of modern radio and T/V equipment.

SUBJECTS INCLUDE:

Mechanics · Chemistry
Photography · Electricity
Carpentry · Electrical Wiring
Electronics · Television · Radio
Short Wave Radio · Draughtsmanship
Art · Oscilloscope. Also many other Home Study Courses without equipment.



MODERATE FEES

POST THIS COUPON TODAY

E.M.I. Institutes, Dept. 197X, London, W.4.

Name _____ (BLOCK CAPS PLEASE)

Address _____

Subject of interest _____ Age _____
(We shall not worry you with callers) (if under 21)

EMI INSTITUTES Associated with "H.M.V.",
OCT. 58 Columbia, etc., etc. IC85

ACCURATE
HARDHITTING

Webley

AIR PISTOLS

AIR RIFLES · ACCESSORIES

Write for catalogue WEBLEY & SCOTT Ltd.
87 WEAMAN ST., BIRMINGHAM 4, ENGLAND



RAILWAY ACCESSORIES

'00' Scale — Hand Finished

Station Staff or Passengers (set of 5) . . .	2/6
Seated Passengers (set of 5) . . .	2/6
Platform Accessories (set of 7) . . .	2/6
W. H. Smith's Bookstall . . .	5/-
Electric Trolley, Trailer and Luggage . . .	2/6
Esoo Oil Drums (set of 6) . . .	2/6
Permanent Way Cabin and Workman . . .	4/9
Goods Yard Crane on Base . . .	10/6
A.A. Box with Patrolman on Motorcycle . . .	3/-

Send 3/6 for sample box of models, illustrated list of over one hundred other models, Wrenn Track, Blitties sheets, etc. Lists only 1/6.

HANNANT'S

56 London Road North, Lowestoft, Suffolk



Obtainable from bookshops
or, plus 1/- postage, from
this address—

Jan Allan 1959 annuals

TRAINS ILLUSTRATED ANNUAL	10/6
LOCOSPOTTERS ANNUAL	6/6
AIRCRAFT ANNUAL	10/6
IAN ALLAN BOOK OF TRAINS	6/-

Take your pick from these four
better-than-ever annuals, packed
with interesting articles and
beautiful photographs.

The perfect gift to give —
and to receive.

LOCOMOTIVE PUBLICATIONS

33 Knolly's Road, Streatham, London S.W.16

● LATEST IAN ALLAN BOOKLIST
SENT FREE ON REQUEST.



FLASH!

and
"ALL
DISTANCE"
PICTURES

coronet CAPTAIN

With this camera you can photograph anything and everything by day or night at all distances from 3 ft. to infinity, in black and white or in colours (colour snaps indoors must be taken by flash, but outdoors you can photograph any subject in direct, bright sunshine). Sold by all Photographic Dealers. Illustrated brochure sent with pleasure.

PRICE
42/5

**CORONET LTD., SUMMER LANE,
BIRMINGHAM 19**



BOND'S

Special Clearance Sale

of

AMERICAN "AURORA" PLASTIC AEROPLANE KITS

Once these stocks have been sold, we cannot repeat at this special Sale Price:

	Usual Price	Sale Price
Convair XFYI Pogo ..	11/9 each	8/6 each
Boeing P26A ..	11/9 each	8/6 each
Lockheed F90 ..	11/9 each	8/6 each
Lockheed Lightning ..	11/9 each	8/6 each

Packing and Postage 1/3 extra

AMERICAN MONOGRAM Balsa WATERLINE BOAT KITS

To make up a model about 16 in. long.

U.S. Navy L.S.T.	U.S. Navy Destroyer
U.S. Navy Cruiser	U.S. Navy Battleship
Usual Price 15/- each	Sale Price 11/- each

Packing and Postage 1/3 extra

Bond's 1958-59 Model Catalogue. Price 2/-

BOND'S O' EUSTON ROAD LTD.

357 EUSTON ROAD, LONDON N.W.1
Est. 1887 Phone EUSTON 5441-2

THE BACK NUMBER SPECIALIST CAN HELP YOU!

Meccano Magazines

Before 1940.. ..	1/- each
1940-1944	9d. "
1945-1949	6d. "
1950-1952	9d. "
1953-1957	1/- "
1958	1/3 "

Railway Magazines

1927-Date	2/- "
-----------------	-------

Trains Illustrated

Volume 2-Dec. 1955 ..	1/6 "
1956-Date	2/- "

Buses Illustrated

1953-Date	2/6 "
-----------------	-------

RAILWAYS

RAILWAY WORLD {All issues to 1958
1/- each

Model Railway News

Model Engineers {All issues to 1958
6d. each

Model Railway Constructor

All issues to 1956 .. 9d. each

Railway Modellers

All issues to 1956 .. 1/6 "
1957 and 1958 .. 2/- "

Cigarette Cards

100 Clean Mixed .. 2/6

Write or Call:

LENS of SUTTON,
50 CARSHALTON ROAD,
SUTTON, SURREY

Please add a little for Postage.

Star-study in comfort

PHILIPS' 6"
CELESTIAL GLOBE
Principal stars in yellow on a light blue ground, and indicating magnitude.

19s. 6d. net

Write for details of Philips' Chart of the Stars and other aids to star-study.

GEORGE PHILIP & SON LTD.
30-32 FLEET STREET, LONDON E.C.4

Crystal Set Kits 15/8

With permanent detectors. Loud and clear reception. No batteries required. Ideal for School or College. Lightweight Headphones 16/4. All post free.

W. BUCKLE, 77 Hórringer Rd., Bury St. Edmunds

LEARN PHOTOGRAPHY

THE PRACTICAL WAY

with our new course, which includes services of skilled tutor for complete help and criticism of prints, etc. Processing equipment supplied with course if required. Moderate fees.

Free Brochure from:

E.M.I. INSTITUTES (Dept. 197K), London W.4.
(Associated with H.M.V.)

G.C.E

Wolsey Hall (est. 1894) can prepare you *successfully* by post for all G.C.E. examinations; Lond. Univ. Degrees and many other exams. Moderate fees, instalments. 30,000 successes since 1930. Prospectus from C. D. PARKER, M.A., LL.D., Dept. GK5,
WOLSEY HALL, OXFORD

STAMP ADVERTISEMENTS

(see also pages 500 and 502)

GT. BRITAIN. 1841 1d. Brown IMPERF. FREE issued in 1841, these stamps are cat. by Gibbons from 1/6d. to £5. I will send ONE average copy of this VALUABLE stamp to each genuine applicant who sends 3d. for postage and asks to see a selection of my "WORTH WHILE" approvals. No stamps sent abroad.
JOS. H. GAZE, 10 PIMLICO Rd., CLITHEROE, LANCs.

VIKINGS DIAMOND PACKET. 27 FREE

Lundy Viking Ship and Eric Bloodaxe, Last of the Vikings, and Laos Giant Elephants, plus 25 other stamps FREE. Send 3d. Post and request Approvals. **ROSEBERY STAMP SERVICE, (Dept. B4), 37 Rosebery Road, Epsom, Surrey**

ELEPHANTS ★ Three huge (2 x 1½) Laos Elephants and one mint GHANA 1st ANNIV. FREE to all sending 3d. post for DISCOUNT APPROVALS.
S. REY (EG), 10 Walsh Ave., BRISTOL 4

LOOK! Super Catalogue of G. VI Stamps absolutely FREE! Classify your collection. Ask for approvals from: **APEX STAMPS** — (Dept. F), 29 Rock Road, Trowbridge, Wilts. —

Do you know



HOW RUBBER FIRST CAME TO THIS COUNTRY?

IN 1736 Charles de la Condamine, a Frenchman, headed an expedition to Peru. He brought back with him details of the native uses of rubber and, more important still, the first-known samples to reach Europe.

In 1791, Samuel Peel took out the first patent in England relating to the practical use of rubber. Thomas Hancock, described as the "father of the rubber industry", carried on this work and in 1819 was devising rubber solutions for the proofing of textiles. About the same time Charles Macintosh, who founded the present Dunlop waterproof clothing company, invented the first waterproof.

In fact, much work had been done to make the raw material softer and more workable. Then came the Dunlop pneumatic tyre which, more than anything else, promoted the widespread use of rubber.

Think of tyres and you
think of **DUNLOP**

04/117

You
never
get
tired
of

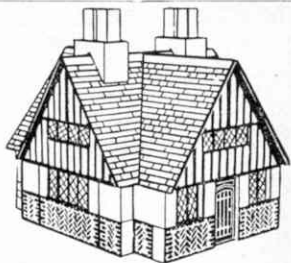

LOTT'S

TOY STONE BUILDING

BRICKS



*What a super
Christmas present!*

They're marvellous—make sure you get a box this year. There's no end to the things you can build with them . . . houses . . . shops . . . railway stations . . . whole villages even! Lott's Bricks are made of coloured artificial stone. To make your models really life-like, there are even transparent window bricks! What a wonderful companion to your model railway set, too. Make sure you get LOTT'S this year!

Sets from 7/2 to 59/6

Enquire of your Toy Dealer or write for Price List enclosing 2d. stamped addressed envelope



FOR OLDER BOYS

**LOTT'S
CHEMISTRY
SETS**

complete with chemicals, apparatus and instructions. Sets from 10/4
SPARES ALWAYS AVAILABLE

LOTT'S BRICKS LTD., Dept. MM 24, WATFORD, HERTS.

READERS' SALES AND WANTS

SALES

Tri-ang 00 Set. For details send to—Holmes, 17 Woodthorpe Road, London S.W.15.

Obsolète Hornby Gauge 0 Locomotives, Clockwork and Electric, Rolling Stock and Accessories, also Trackwork and Equipment by other manufacturers. S.A.E. for list—D. V. Abbott, 29 Priory Road, Newbury, Berks.

"M.M.s." June 1950 to June 1958 inclusive. Mint condition. Sold separately or in numbers. Offers—G. Fairweather, 1 Lime Street, Logie, Dundee.

"M.M.s." July 1951 to September 1957. Only 4 missing. Excellent condition. What offers?—Simpson, Ashwood, Hallow, Worcs.

M.M.s." January 1955 to April 1958 complete, excellent condition. Offers to—Deavin, 5 Coldecote Gardens, Bushey, Herts.

Charles Atlas Body Building Course, complete. Great saving at £5 or nearest.—Box MM18.

"M.M.s." December 1939, March and May 1940. Offers to—Mr. Sayers, 85 Winchester Road, Kenton, Middlesex. 1,500 Stamps and Album for best offer.—C. Kennedy, Poldean, Beattock, Dumfriesshire.

Bayko No. 2 Set, plus extras, Good condition 25/- o.n.o.—20 Edge View Walk, Kinver, Staffs.

Aircraft Books, perfect: Including Books costing 12/- to 35/-, over £13 worth. The lot £2 plus postage, genuine—Colin Kippax, 108 Bispham Road, Southport, Lancs.

"M.M.s." 1941 (June and October missing); 1942; 1943 (June and July missing); 1944 (except June); 1945; and 8 issues 1946. Good condition. Offers to—Penson, 142 Blake Road, West Bridgford, Nottingham.

"M.M.s." January 1949 to February 1953—50 copies. Offers to—Bing, Rempstone Road, East Leake, Loughborough, Leics.

"M.M.s." March 1955 to June 1958. Excellent condition, £1.—Clough, 13 Brampton Road, Bolton, Lancs.

Good E.D. 1 c.c. Diesel 30s. Numerous Minics, Games, etc. S.A.E. details—C. Morrell, 15 Gallows Hill, Hunton Bridge, Herts.

HORNBY LOCOMOTIVE PART EXCHANGE COUPON

Complete this coupon, and hand it, with your old clockwork locomotive, to your Meccano dealer, who will deduct the appropriate amount, as shown below, from the cost of a new Hornby-Dublo Locomotive or Train Set.

Old Loco	Allowance	Indicated by cross which type exchanged
MO or No. 20	3/-
M1 or No. 30	5/-
Nos. 101 or 40 Tank	7/6
No. 501 or No. 50/51	9/-

Type of Hornby-Dublo Locomotive or Train Set purchased in exchange.....

Purchaser's signature.....

Address.....

DEALER'S CERTIFICATE

The above exchange has been effected in accordance with the terms of the Hornby Part-Exchange Scheme.

Signed.....
Meccano Dealer

Dealer's Name.....

Address.....

Date..... (U.K. only)

MECCANO MAGAZINE

Registered at the G.P.O., London, for transmission by Canadian Magazine Post.

EDITORIAL AND ADVERTISING OFFICES:
LIVERPOOL 13, ENGLAND.

Telegrams: "Meccano, Liverpool."

Readers' Sales and Wants. Private advertisements (i.e. not trade) are charged 2d. per word, minimum 2/-. Cash with order. Readers' advertisements are published as soon as possible; inclusion in the first issue after receiving them cannot be guaranteed.

Advertisements of goods currently manufactured by Meccano Ltd. cannot be accepted.

"M.M.s." March 1948 to January 1954. Good condition. Any offer considered.—Kirby, 4 Charnwood Road, Salisbury.

1954 Whole World Stamp collection (value £10) in Album and Booklet, Catalogue (excellent condition) all for £4.—C. Bryan, 7 Duchess Road, Clifton, Bristol 8. Tri-ang and Trix items. S.A.E. list.—M. M. Denny, 64 William Street, Long Eaton, Nottingham, Phone: Long Eaton 3219.

Old Railway Books, Magazines, Timetables and Photographs for sale. List: 2d. S.A.E.—Livesey, 56 Berkeley Avenue, Greenford, Middlesex.

"M.M.s." December 1947 to May 1955. All excellent condition. Will split. What offer?—F. D. Pilcher, 90 Mickleburgh Hill, Herne Bay, Kent.

Wrenn Track, 4 yards, in different lengths, 18/- Crossover, £1. Point, 7/6.—Price, Wentworth, Shanklin, I.O.W.

"M.M.s." 1943 to 1946, bound volumes; 1947 to 1952 unbound (2 missing). Offers—A. W. Hakim, Applegarth, Green Lane, Stanmore, Middlesex.

"M.M.s." November 1940 to December 1950. Complete. Two guineas or offer.—Izzett, 21 Otley Road, Harrogate.

120 Brownie Camera and Case. Gauge 0 Clockwork Train Set. Extra Rails and Trucks. Cost £11. Excellent condition. Offers. Many other offers. S.A.E. for list.—Michael Lynn, The Old Vicarage, Great Paxton, Hunts.

"M.M.s." January 1956 to February 1958. Perfect 25/-.—Jarman, 56 St. Austell Drive, Wilford, Nottingham.

"M.M.s." January 1951 to January 1958, excellent, one missing, £2. Postage paid.—Walker, Muirs, Kinross.

Bayko Building Set No. 3 with many spare parts added. Offers—Born, 4 Malvern College, Malvern, Worcs.

"M.M.s." December 1947, March 1949 and May 1949 to December 1955. Excellent condition. 6d. per copy, postage paid.—A. B. Morehouse, 3 Raby Road, Doncaster, Yorks.

Mamod Minor Steam Engine, excellent condition, 15/-, 2 Cycle Wheels 26" x 1 1/2", both with Tyre and Tube. Front with complete S.A. Dynohub Lights. Rear with S.A. 3-speed Gears 30/- each.—Charlson, 89 Market Street, Stalybridge, Cheshire.

1,500 Stamps, catalogue value £17, for 70/-, o.n.o.—Hyde, 243 Gleanness Road, Sheffield 2.

Obsolète Dinky Toys and Britain Farm, list.—Lury, Ardmohr, East Calder, Midlothian.

WANTS

"M.M.s." before 1921. Nos. 1-15 inclusive, £1 each issue if in good condition. Also Books and Prize Models, Books of New Models, Old Instruction Books for ordinary Outfits, Aeroplane Outfits, Motor Outfits ext. 1935 Standard Mechanisms Manual, anything Pre-war. Also Geared Roller Bearing. Also contact other collectors with view of exchange surplus Literature and Parts. No separate sales. Details—Daniels, 67 Holly Road, Twickenham, Middlesex.

Ex R.A.F. 1/72nd Scale Plastic Recognition Model Aircraft (Wartime Types).—P. A. Wilkins, 5 Holly Road, Northampton.

Obsolète Dinky Military Aircraft. Good condition, state price.—Garratt, 5 College Road, Epsom, Surrey.

Planning your Hornby-Dublo Railway

No.2

Here's an interesting Hornby-Dublo Railway layout with double track, S-shaped internal loop, branch lines serving stations, sidings, points and crossings.

See how attractive it looks in the picture below—complete with train sets and accessories.

It is an example from the latest edition of the booklet *Hornby-Dublo Rail Layouts* (price 6d. from Meccano Dealers or direct from Meccano Ltd., Binns Road, Liverpool 13).

The layouts featured in the Booklet vary from the simplest single track layouts to more complicated double track systems, and in addition there are diagrams of special layout sections, all fully explained, showing how to build up original layouts or extensions of those illustrated.

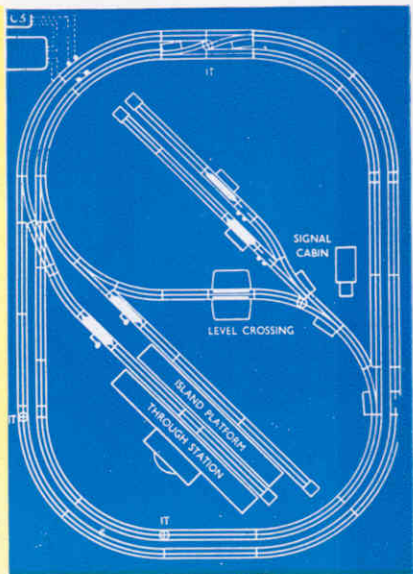

Meccano Ltd.
Binns Road, Liverpool 13

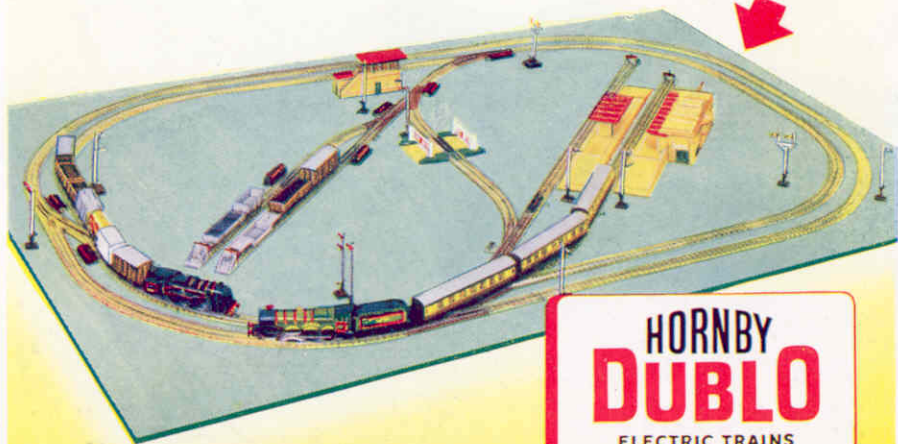

**HORNBY
DUBLO**
ELECTRIC TRAINS

New

meccanoindex.co.uk
DINKY TOYS

TRADE MARK REGISTERED

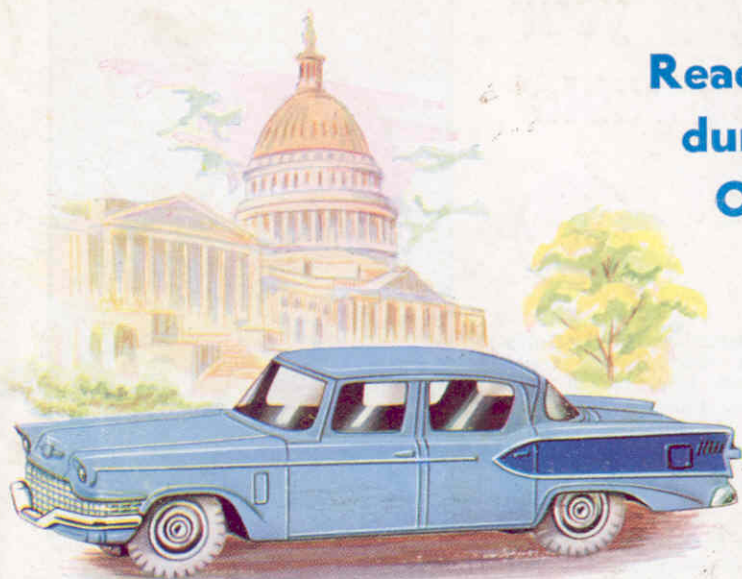

**Ready
during
OCTOBER**

**WITH
WINDOWS**

**Dinky Toys No. 179
STUDEBAKER
PRESIDENT**

Here's a perfect miniature replica of this famous American automobile, accurate in every detail of its distinctive styling. And look at those white tyres, bright duo-tone body and transparent windows—she's a beauty.
Length: 4 $\frac{5}{8}$ in.

U.K. Price: 3/6 (inc. tax)



**Dinky Toys No. 693
7.2 HOWITZER**

This accurate miniature of the powerful 7.2 in. Howitzer is the latest in the Dinky Toys series of Army ordnance models. A spring-loaded pivot balanced on the cradle trunnions enables the gun barrel to be raised and lowered by finger tip control. You'll want to add this Howitzer to your collection of Dinky Toys army models—it's in the shops now.
Length: 5 $\frac{1}{2}$ in.

U.K. Price: 3/6 (inc. tax)

MADE IN ENGLAND BY MECCANO LIMITED

Published by MECCANO LTD., BONAS ROAD, LIVERPOOL 13, ENGLAND
Printed by John Waddington Ltd., Leeds and London