

# MECCANO<sup>®</sup> Magazine

★ MICROSCOPES ★  
★ MECCANO MODELS ★  
★ CYCLE RACING ★

THREE SHILLINGS  
U.S.A. AND CANADA 70 CENTS.



HOBBY MAGAZINE

THE PRACTICAL BOY'S LEISURE TIME MAGAZINE



MODEL ENGINEER

EXHIBITION 1970

# Make your own Jig-Saw puzzles!

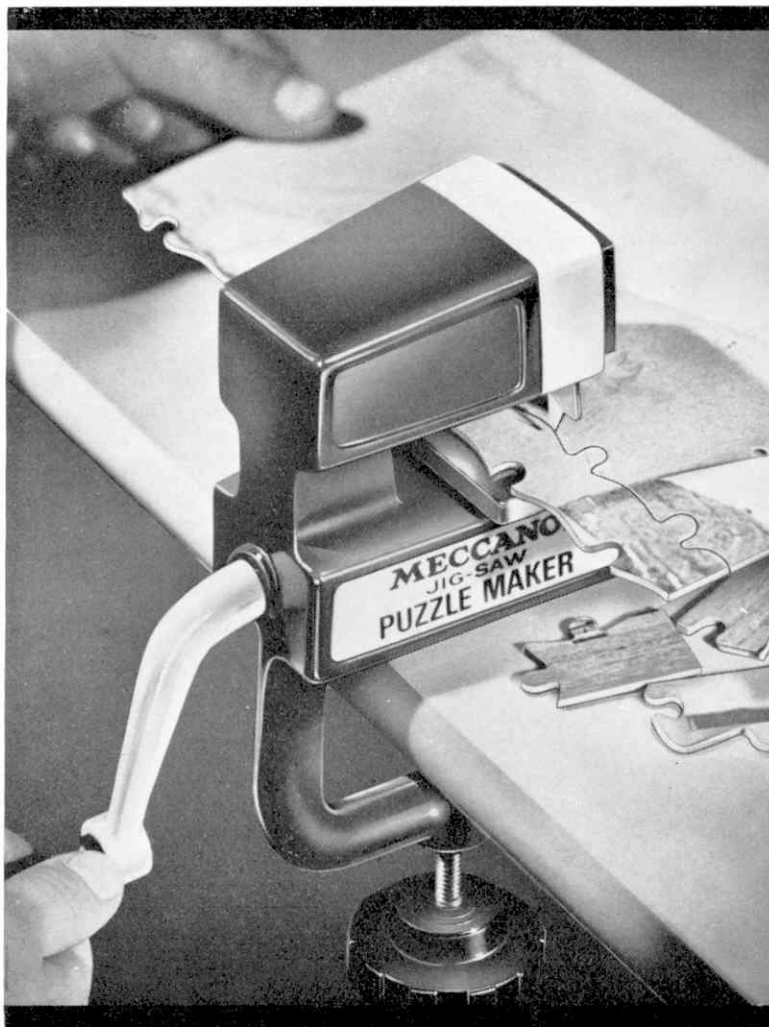

It's fun cutting out puzzles of different shapes and sizes and lots more fun making them up afterwards.

Now you can turn any picture into an exciting jig-saw, in whatever shape you choose. Jig-saws can be made out of almost anything from calendars, postcards, cereal packs etc. Just place the picture under the cutting blade and turn the handle and you will have taken the first step in making a jig-saw to your own design. 4 colour pictures are included to start you making your own jig-saw puzzles. Price: 42/6



**MECCANO®**

**JIG-SAW**

**PUZZLE MAKER**



# MECCANO<sup>®</sup> Magazine

FEBRUARY 1970 VOLUME 55 NUMBER 2  
Meccano Magazine, founded 1916.

Editorial Director  
**D. J. LAIDLAW-DICKSON**

Editor  
**DAVE ROTHWELL**

Consulting Editor for Meccano Ltd.  
**J. D. McHARD**

Advertising Manager  
**ROLAND SUTTON**



## FRONT COVER

Taken by Stephen Goodger, who's feature *The Tour of Britain Cycle Race* appears inside this issue, this month's cover shows the finish of this year's event, and neatly sums up the effort and concentration needed to successfully compete in this gruelling race.

## NEXT MONTH

The March issue of *Meccano Magazine* is packed with a variety of articles covering subjects as far apart as *Prospecting for Gold and Air Rifle and Pistol Maintenance*.

For readers interested in the topical subject of the *Moon Landings*, Mike Rickett describes and illustrates in detail, the latest Space-suits as worn by the American Astronauts. *Meccano* features prominently in the March issue with models for enthusiasts both young and old. Part 3 of Bert Love's *Meccano Constructors' Guide* (fast becoming a firm favourite) is included; and whilst on the subject of *Meccano*, some important news concerning this fascinating constructional system.

To round off the issue, features by some of the most popular contributors, such as Charles Rigby, James A. Mackay and Charles Grant all help to ensure that our March issue is kept to its established standards.

Advertisements and Subscription Offices: Model & Allied Publications Ltd., 13-35 Bridge Street, Hemel Hempstead, Hertfordshire. Tel.: Hemel Hempstead 2501-2-3.

Second class postage rates paid at New York, N.Y. Registered at the G.P.O. for transmission by Canadian Post. American enquiries regarding subscriptions, news stand sales and advertising should be sent to MECCANO MAGAZINE, Eastern News Distributors Inc., 155 West 15th Street, New York, N.Y. 10011, U.S.A., U.S.A. and Canada direct subscription rates \$5 including index.

This periodical is sold subject to the following conditions: that it shall not, without the written consent of the publishers, be lent, re-sold, hired-out or otherwise disposed of by way of Trade at a price in excess of the recommended maximum price and that it shall not be lent, re-sold, hired-out or otherwise disposed of in a mutilated condition, or in any unauthorised cover by way of Trade; or affixed to or as part of any publication of advertising, literary or pictorial matter whatsoever.

Publishers of Aeromodeller, Model Boats, Model Cars, Model Engineer, Radio Control Models, Model Railway News, Scale Models.

**MODEL & ALLIED PUBLICATIONS LTD.**

**13-35 BRIDGE STREET, HEMEL HEMPSTEAD, HERTFORDSHIRE**

## CONTENTS

<b>WORKBENCH</b>	69
<i>News and views by the Editor</i>	
<b>MICROSCOPY AND ITS DEVELOPMENTS</b>	70
<i>The Story of the microscope and its development to the present day</i>	
<b>MICROSCOPE REVIEW</b>	72
<i>A review of R. Kohnstam's microscope sets</i>	
<b>MECCANO CONSTRUCTORS' GUIDE</b>	74
<i>Part 2—Gears, Sprockets and Pulleys</i>	
<b>GIANT MODEL OF INFLAMMATION</b>	78
<i>An amazing surgical model showing the stages of inflammation</i>	
<b>WHISKY CART</b>	79
<i>A simple Meccano model</i>	
<b>COINS ON STAMPS</b>	80
<i>Stamps on a theme by James A. Mackay</i>	
<b>SIMPLE SCOOTER</b>	81
<i>A 'Simplicity' model in Meccano</i>	
<b>ELEVATOR LOADER</b>	82
<i>A working model in Meccano</i>	
<b>ON TWO WHEELS</b>	84
<i>Test No. 6—Vespa Primavera</i>	
<b>THE A.B.C. OF COMPUTERS</b>	88
<i>The theory of logic concluded</i>	
<b>TOUR OF BRITAIN CYCLE RACE</b>	90
<i>A look at the world's toughest cycle race</i>	
<b>GREAT ENGINEERS</b>	93
<i>No. 25 James Nasmyth</i>	
<b>OIL FROM THE ARCTIC</b>	94
<i>How oil is pumped under the severe conditions of the Arctic</i>	
<b>AMONG THE MODEL BUILDERS</b>	97
<i>Readers' Meccano ideas</i>	
<b>TRANSPORT TOPICS</b>	99
<i>Mike Rickett talks about the Nimrod</i>	
<b>NIAGARA FALLS ARE FALLING DOWN</b>	100
<i>The problems of water erosion on a "Wonder-of-the-World"</i>	
<b>COMBINE HARVESTER</b>	102
<i>Construction of a superb Meccano model</i>	
<b>H.M.S. COSSACK</b>	104
<i>Describing the prize-winning Meccano Model</i>	
<b>FIRE-WALKERS OF SOUTH INDIA</b>	106
<i>An eye witness account of this amazing ceremony</i>	
<b>BATTLE</b>	108
<i>Part XXII—Reconnaissance in force</i>	
<b>MILITARIA</b>	110
<i>Military review by Charles Grant</i>	
<b>HAVE YOU SEEN?</b>	112
<i>Latest products reviewed</i>	
<b>RADIO 4-2 CAR</b>	114
<i>Converted plastic kit into radio control</i>	

# Simple Cardboard Models

## SIMPLE CARDBOARD MODELS

G. H. DEASON

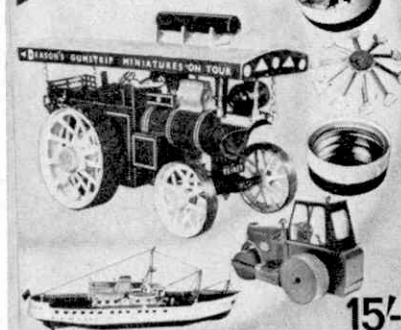

This magnificently illustrated book deals with working models of Rollers, Road Engines, Ships, Cars, Tracklaying Vehicles, Rail and Tramway models and other working models including models of *RMS Scillonian* and the *Ruston Bucyrus Excavator*.

9½ x 7½ in. 120 pages, square backed, drawn on two-colour picture cover. 75 photo illustrations; 77 drawings including working plans.

Price 15s. post free from:  
Model & Allied Publications Limited  
13-35 Bridge Street, Hemel Hempstead  
Hertfordshire.

## LOOK IT COSTS YOU NOTHING

To find out more about the many interesting products advertised in this issue of MECCANO Magazine, just tick the squares against the name of the advertiser from whom you would like to receive more product information and post it to: Advertisement Information, Meccano Magazine, 13/35 Bridge Street, Hemel Hempstead, Herts.

### FEBRUARY COUPON

- |   |  |
|---|--|
| <input type="checkbox"/> Beatties           | <input type="checkbox"/> Meccano Ltd. (Dinky)      |
| <input type="checkbox"/> J. W. Bagnall Ltd. | <input type="checkbox"/> Radio Control Specialists |
| <input type="checkbox"/> A. N. Beck         | <input type="checkbox"/> Royal Navy Recruiting     |
| <input type="checkbox"/> Hammant & Morgan   | <input type="checkbox"/> Rovex                     |
| <input type="checkbox"/> Humber Oil Co.     | <input type="checkbox"/> Subbuteo Sports Games     |
| <input type="checkbox"/> Meccano Ltd.       |  |

Name.....

Address.....



# Now £100,000 INSURANCE

Model & Allied Publications Limited

13-35 Bridge St.,  
Hemel Hempstead,  
Herts.

We are happy to announce that our already well-known third party insurance for readers has now been increased to offer indemnity of £100,000! This magnificent insurance scheme, which covers modelling activities within Great Britain, Northern Ireland, Channel Islands and the Isle of Man, has been negotiated with a leading insurance company. It is sufficiently embracing to cover all forms of model activity. It is equally applicable to free flight models, control line models, radio control models, aircraft, boats, cars and locomotives.

All that is necessary for you to do to obtain the benefits of this magnificent cover is to complete the forms at the right of this announcement, sending the first part to us together with your remittance of 5/-, which covers you for one year, and handing the second part to your usual magazine supplier. Whether or not you already have an order in hand for the regular supply of your magazine, this form should still be handed in and your dealer will adjust his requirements according to whether you are a new customer or merely continuing your old arrangement.

This insurance is the prudent thing for every modeller to take out, but it is a sad fact that until now, although the governing bodies of the hobby have offered this cover to their members, something like 90 per cent. of the modellers in the U.K. have never taken up this opportunity and are operating 'without insurance protection'. By joining M.A.P. 'Modellers' Accident Protection' you come into the world's BIGGEST MODEL CLUB. For your initial subscription you obtain a lapel badge for identification and transfers to put on your model.

Complete the form and send on at once. We will send you back your membership card, lapel badge and waterslide transfers immediately.

### M.A.P. INSURANCE MEMBERSHIP FORM

PART I to be handed to Newsagent

To \_\_\_\_\_

Please \*reserve/deliver one copy of \*AEROMODELLER/MODEL BOATS/ MODEL CARS/RADIO CONTROL MODELS & ELECTRONICS/ SCALE MODELS/MODEL ENGINEER/MODEL RAILWAY NEWS/ MECCANO MAGAZINE, commencing with the \_\_\_\_\_ issue. (\*Delete as applicable.)

Name \_\_\_\_\_

Address \_\_\_\_\_

PART II of the Form should be completed and sent to us at the address above left, together with your remittance of 5/-. PART I should be handed to your usual supplier, either newsagent, model shop, bookseller or wherever you normally expect to get your magazine.

PART II to be sent to M.A.P. Ltd.

Name (in full) \_\_\_\_\_

Address \_\_\_\_\_

Date \_\_\_\_\_

I enclose herewith postal order value 5/- for membership of M.A.P. £100,000 insurance scheme. This sum, I understand, includes two transfers and a lapel badge, and is conditional upon my ordering.

\* AEROMODELLER/MODEL BOATS/MODEL CARS/RADIO CONTROL MODELS & ELECTRONICS/SCALE MODELS/MODEL ENGINEER/ MODEL RAILWAY NEWS/MECCANO MAGAZINE: (\*Delete those not applicable.)

I have today instructed my newsagent \_\_\_\_\_

Address \_\_\_\_\_

to deliver me the magazine \_\_\_\_\_ until further notice.

KINDLY MENTION "MECCANO MAGAZINE" WHEN REPLYING TO ADVERTISEMENTS



# 15-17½?

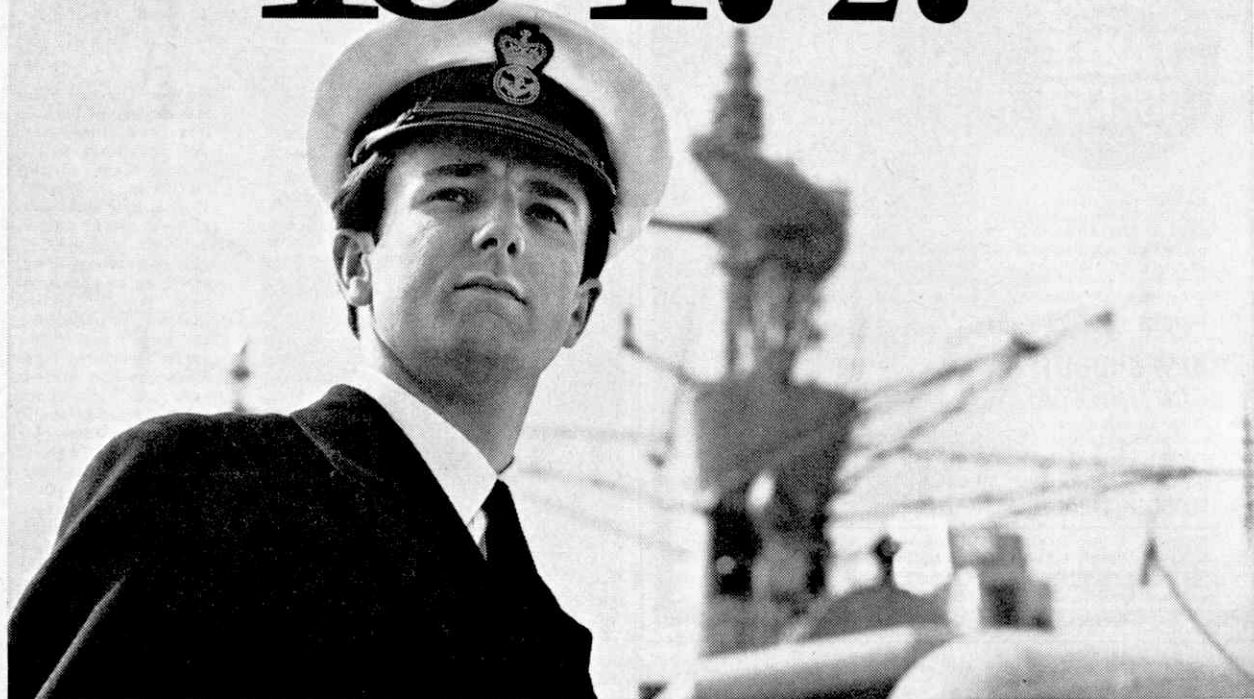

## Book the Apprenticeship with built-in adventure.

Are you keen on a skilled trade—but don't want to end up at a factory bench? We know how you feel. And we've got the answer. An Artificer Apprenticeship in the Royal Navy.

**A KEY TECHNICIAN.** The Navy will train you to be one of its top technicians. The man who looks after exciting modern equipment in ships, submarines and helicopters—like missiles, electronic systems, computers, radar, gas and steam turbines.

**4-YEAR TRAINING.** This is one of the finest apprenticeships in the world. 4 years' expert training at naval technical schools. You'll have a great time. You're in good company. There's plenty of sport. Most of your pay is pocket money. And you get nine weeks' holiday a year!

**FULL UNION STATUS.** Your training leads to your O.N.C. and full union status. Ensures you a well-paid job—in the Navy or out.

£1,600 PLUS! Promotion is excellent. You should be a Petty Officer at 21-22, and a Chief Petty Officer at 25-24—earning, if married, over £1,600 a year. And you have a very good chance of becoming a commissioned officer.

**TRAVEL TOO.** The Navy also gives you adventure, excitement—and a chance to see something of the world.

**FIND OUT MORE.** To enter the Navy as an Artificer Apprentice, you must be 15½-17½ and pass an entry exam.

(With 'O' level or C.S.E. Grade 1 Maths, plus one Science subject or English Language, you are exempt from the written part.) If you're 17½-23 you can apply for a Mechanician Apprenticeship. Post the coupon now.

### Send for free book.

Royal Naval Careers Service  
(Apprenticeships (703GU1),  
Old Admiralty Bldg., London, SW.1.  
Please send me full details without  
obligation.

Name

Address

Date of birth

(Enquiries from  
U.K. residents only)

**RN**  
ROYAL NAVY



KINDLY MENTION "MECCANO MAGAZINE" WHEN REPLYING TO ADVERTISEMENTS

THE REPLICA  
OF  
ASSOCIATION  
FOOTBALL

**SUBBUTED**  
Rep.  
**TABLE  
SOCCER**



Here is a game where victory or defeat depends upon the skill of the player with fingertip control. COMPLETE with goals, balls etc. and teams available in all League Club colours. Played with 22 miniature men. All the thrills of real League, Cup and International Football: dribbling, corner and penalty kicks, offside, goal saves, etc.

PRICES 12'6 · 22'6 · 52'6

**NEW SUBBUTED  
CONTINENTAL**

editions with 00 Scale Teams, hand painted in all League colours, on duotone coloured bases, etc.

INTERNATIONAL 125' -  
FLOODLIGHTING 95' -

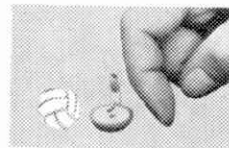

CLUB 65' -  
DISPLAY 32'6

Please ask at your local Sports or Toyshop or Department Store. In case of difficulty write for literature and lists of stockists to

**SUBBUTED** Dept. 5 Langton Green  
Tunbridge Wells, Kent

## Introduction to Battle Gaming 21s

INTRODUCTION TO  
**BATTLE  
GAMING**



Author Terence Wise is a master of his subject and introduces the newcomer to the many facets of this fascinating hobby in 12 chapters and numerous appendices. Subjects include Origins of battle gaming; choosing an era; basic field layout; adding realism; organising an army; rules for ancient warfare; rules for horse and musket era; rules for modern warfare; variations of the game; ideas for advanced players; making model soldiers; final touches. 7½ x 4¾". 160 pages, hard bound in linsol boards, with full-colour dust cover specially posed. Profusely illustrated throughout.

## Aero Modeller Annual 1969-70

Laurie Bagley cover: R/C scale model Whirlwind in bright yellow livery. To tie in with this Dieter Schlueter's fine article on Model Helicopter Technology. (Dieter was winner of 1st International R/C Helicopter Event—also reported in this Annual). John Burkham, of U.S.A. (who won their first 'Copter event), adds comments. Articles include Tubular Fuselages from Balsa; Contest Model Performance Prediction; Beginners Only Please; Facts About Propellers; Glider Construction Suggestions; Navy Carrier Event and What It's All About; Fuel Control; Fifty model plans—all scaled and with main dimensions shown—from the year's best, most interesting, curious, screwball, intriguing, different designs.

8½ x 5½ in., 128 pages. Hard board cover with full-colour cover painting.

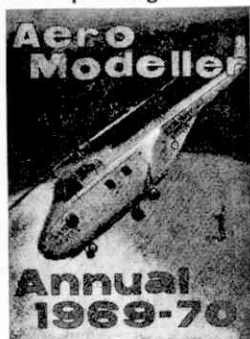

Price 10s 6d + 1s p & p  
from:

Model & Allied Publications Ltd  
13-35 Bridge Street  
Hemel Hempstead, Herts.

ANNOUNCING THE 1970 H & M  
**MINIPACK**



PRICE **54/-**

The most modern-style power-control unit suitable for operating all D.C. motors of up to 12 volts ¾ amp. rating. Smooth progressive control with high/low resistance switch. Fully protected and guaranteed. Operates from 200-240 v. A.C. mains.

SEND FOR FREE PRICE LIST  
OR COMPLETE CATALOGUE 1/-

**HAMMANT & MORGAN LTD.**  
HANDEM WORKS, APEM ESTATE  
134 ST. ALBANS ROAD, WATFORD, HERTS.

KINDLY MENTION "MECCANO MAGAZINE" WHEN REPLYING TO ADVERTISEMENTS



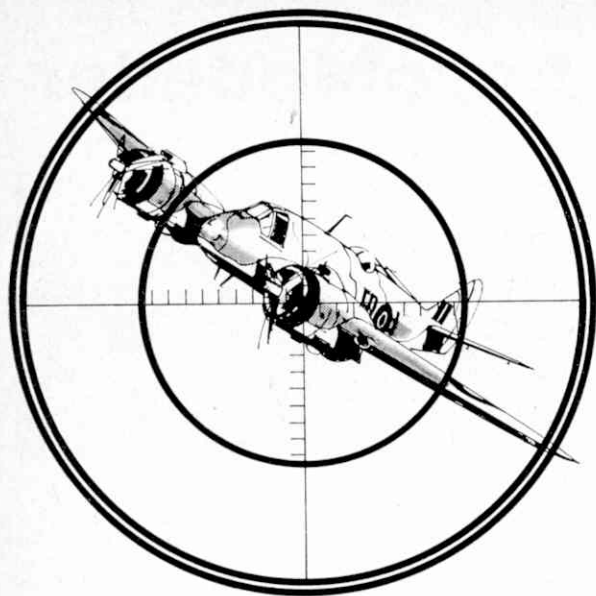

# Be on target with **FROG** kits

It's the famous Bristol Beaufighter just one of the superb 1/72nd. scale kits from Frog. **Only 6/-.** (Ref. No. F191)

### Which profile for you?

You can make this kit in three alternative ways. Parts, markings and colour painting guide are included for bomber or night fighter versions of the Beaufighter.

NF.1 Night Fighter  
F Lt. John Cunningham  
(14 kills) No. 604  
Squadron, 1940-1

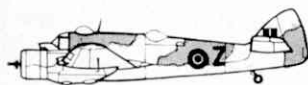

F6C Fighter Bomber  
P/O D. W. Schmidt  
No. 227 Squadron  
Malta, 1942

Or for TF10 Coastal Command, No. 235 Squadron

## Get FROG in your sights! Test your skill on these kits as well



Supermarine Spitfire Mk14  
(Ref. No. F194) Parts and markings  
for aircraft of Punjab Squadron (R.A.F.)  
Belgium or 132 Squadron (R.A.F.)  
S.E.A.C., Hong Kong; plus German  
'Flying Bomb'. 4/3d.



Curtiss P-40 Tomahawk  
(Ref. No. F197F) Parts and markings  
for aircraft of 2nd Pursuit Squadron  
(U.S.A.F.), Burma, or 250 Squadron  
Desert Air Force (R.A.F.), (flown by  
F/Lt. Clive 'Killer' Caldwell). 3/-.

# British Aircraft Carriers

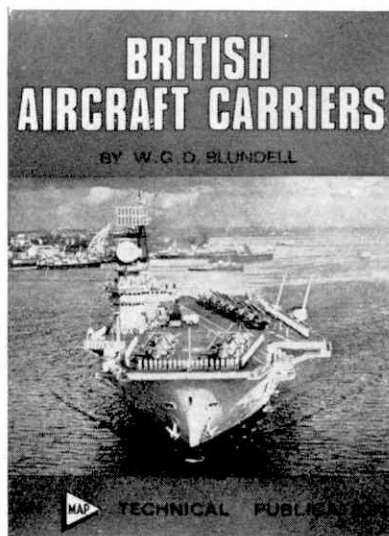

This book covers—unless there is a major policy change—the complete history of British aircraft carriers from the first conversions of 1914 to the last of the ships currently in service. Twenty chapters cover each individual, or class of, carrier, with 16 drawings and 67 half- or full-page photographs, plus detailed notes of the career of every vessel. 104 art paper pages, size 9½ x 7¼ in., cloth bound in hard covers with gold blocked title and attractive dust jacket.

Price 35s. Post free from:  
Model & Allied Publications Limited  
13-35 Bridge Street, Hemel Hempstead  
Hertfordshire.

## MECCANO SPARES

WORLD WIDE

## MAIL ORDER SERVICE

Don't wait for Meccano Sets or Spares—  
We will send them by return post if you  
cannot visit our wonderful shops.

### MODEL RAILWAYS — KITS — CARS & MODEL BOAT KITS

The Beatties Model Catalogue contains over  
100 large pages of information and prices.  
Revised regularly by modellers for modellers.

2/- (POST 1/-  
2/- REFUND VOUCHER)

## BEATTIES OF LONDON

10 BROADWAY, SOUTHGATE, N.14  
112 HIGH HOLBORN, LONDON W.C.1  
28 CORPORATION STREET, MANCHESTER  
18 KING CHARLES STREET, LEEDS 1

KINDLY MENTION "MECCANO MAGAZINE" WHEN REPLYING TO ADVERTISEMENTS

# PLANS



## Radio 4-2 offer!

**3 booklets and  
3 full size working  
plans for constructing  
simple single channel  
radio controlled models  
of cars, a boat and  
a plane**

All in a wallet at the  
special price of 5s  
post free

**BABY CAT Plan 100**

A 13" Catamaran

**SWINGER Plan 101**

A swing-wing catapult glider

**BABY DELTA Plan 102**

An offshore power boat using Electric or Jetex

**MINI-COPTER Plan 103**

A rubber powered helicopter

**FLEX WING Plan 104**

A simple kite-like glider

**PROPSTERS Plan 105**

A rubber powered racing car

**RAM HYDRO Plan 106**

Diesel or glow-plug powered hydroplane

MAP Plans Service

13-35 Bridge Street, Hemel Hempstead  
Hertfordshire

# AeroModeller

February issue



On Sale January 16

Messerschmitt Me 410 drawings by Ian Stair, plus close-up photo detail and **FULLSIZE PLANS** for Harry Purser's 36 inch 'Snipe' for single-channel sports flying with W. I. Barrett's 'Phoebus' 30 in. glider on the flip side: plus 'Karatter', an elliptical surface 36 in. Rat Racer by K. Poulton and C. Thurley are four top-line drawing feature. All-sheet A/2 model construction as described by the German aces, Peter Chinn's engine test and John O'Donnell's comments on engines for free flight plus regular features offer another great issue on sale January 16th.

In case of difficulty from:

MODEL & ALLIED PUBLICATIONS LIMITED,  
13-35 Bridge Street, Hemel Hempstead, Hertfordshire.  
Price 3s. plus 5d. first class postage.

## A SELECTION OF EQUIPMENT FOR 1st YEAR STUDENTS

Book of experiments	2/-	6 lengths tubing	1/-	Evap. Basin	2/10
100ml Beaker	2/10	2" funnel	2/10	Dropper	4d.
100ml Conical Flask	3/2	100 filter papers	1/4	Red & Blue litmus	1/-
2 hole bung	6d.	1ft rubber tubing	7d.	5ml subd. pipette	3/10

Save 2/3d. — Above items 25/- post paid

Worthwhile—a visit to our showroom — look around our large range of more advanced equipment and well stocked selection of chemicals for the serious chemistry and biological student. Send S.A.E. for Price List

## A. N. BECK & SONS SCIENTIFIC

147 HIGH ROAD · LONDON · N.15 Tel: 01-800 7342  
300 yds. south Seven Sisters Station, B.R. and Victoria line. Opposite  
South Tottenham Station B.R.

KINDLY MENTION "MECCANO MAGAZINE" WHEN REPLYING TO ADVERTISEMENTS





## ON THE EDITOR'S DESK

### Exit Workbench

Since I took over as Editor of *Meccano Magazine*, less and less time has been spent at the workbench, and more and more time spent behind my desk.

Keeping a balance of top features, and deciding exactly how they should be presented is a time consuming task, and steadily rising sales of the magazine are proving that it pays off. This swing towards desk work and away from bench work, I felt needed a change in the heading of this page, and this issue sees that change. I sincerely hope you will approve!

## COMPETITION WINNER CLASS II

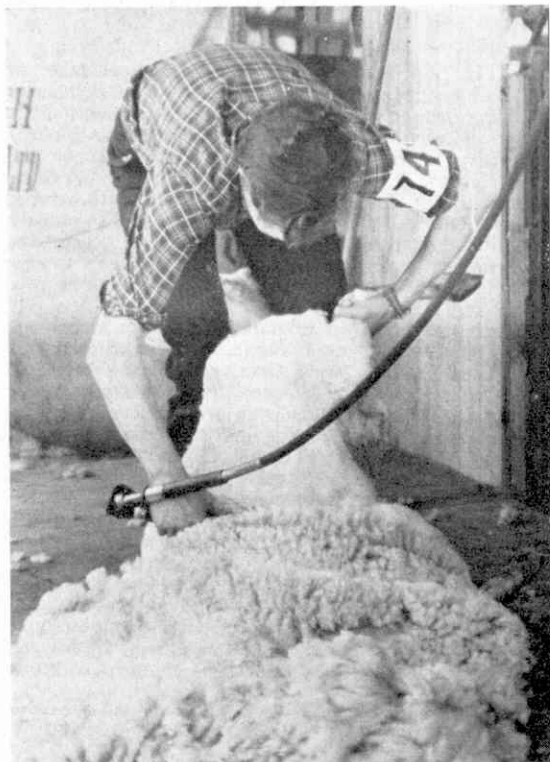

This rather unusual photograph, taken at a sheep shearing contest wins £2 2s. 0d. for Mrs. C. Williams of Shrewsbury, Shropshire. Second place prize of 10s. 6d. goes to Mrs. A. Belton of Hemel Hempstead, Herts.

## COMPETITION WINNER CLASS I



Blaise Hamlet, Henbury, Bristol, this month's "National Trust" Section winner was taken by Peter Hurst of Coombe Dingle, Bristol; and wins him £2 2s. 0d. Runner up was A. Dixon, of Ayr, Scotland, who wins 10s. 6d.

### Old microscope

The main theme of this issue is microscopes, and I thought readers would like to compare the photograph on this page with one of the more recent types as are to be seen on pages 72 and 73. The microscope in question looks very similar to the modern types, so it may come as a bit of a surprise to hear that it celebrates its 90th birthday very soon!

It stands a little over 8 inches tall, is constructed of brass, and has a magnification of X100. It came in a strong wooden box, complete with five specimen slides and a pair of brass tweezers; and cost when new a couple of shillings.

Excellent though they may be, today's microscopes cannot beat that for value!

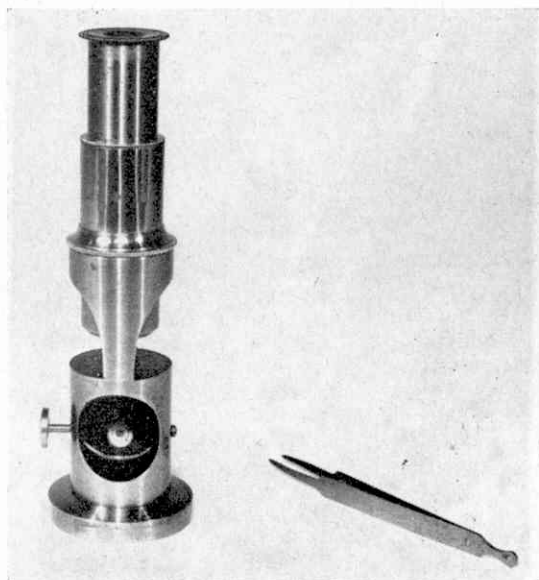

*No other single instrument has proved to be of so much value, particularly in the field of research than the microscope. In this feature Charles Rigby outlines the story of . . . .*

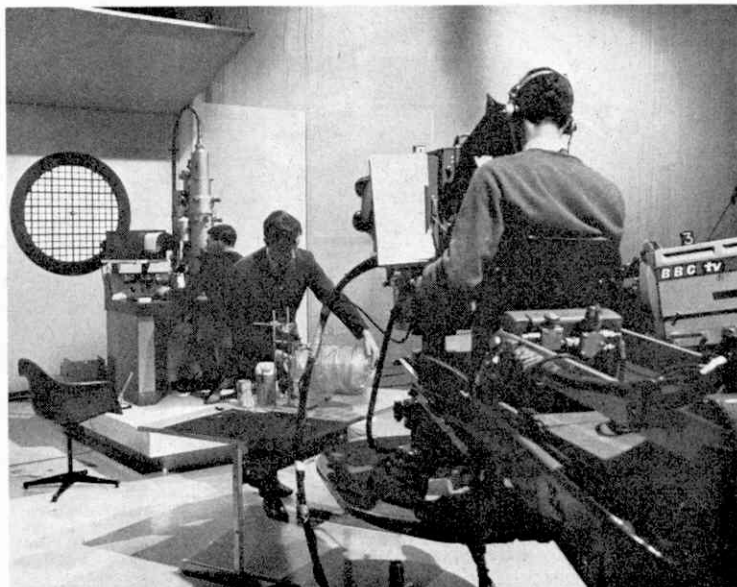

## MICROSCOPY AND ITS DEVELOPMENTS

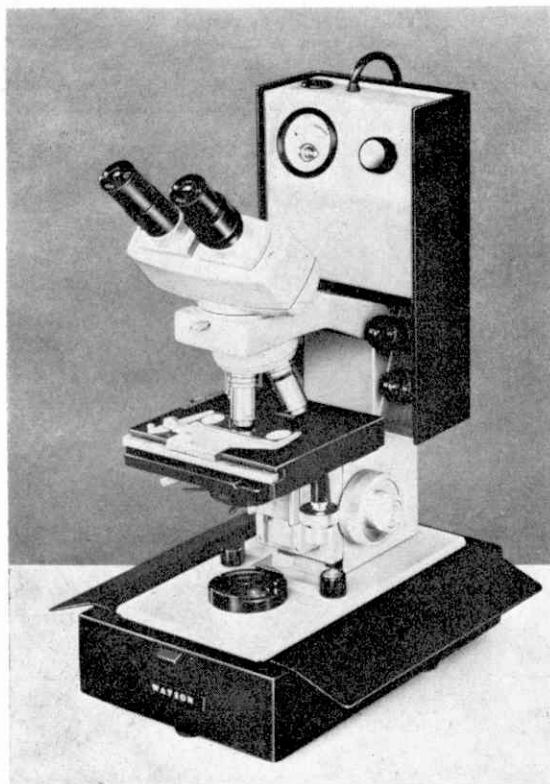

WITH ITS special lens system which enlarges an object many times for close study of specimens, the microscope is a most important instrument. They are most essential in the study of subjects as biology, chemistry, science, metallurgy, medicine, philately, and many others. Regarding its true origin, there are many claims, the instrument itself being gradually developed for various purposes. The first principle, namely, magnification, was discovered in the 10th century by an Arabian known as Alhazen, who wrote a treatise describing the way a curved glass lens could be used to bend light rays.

Much later, both in England and on the Continent, 'magnifiers' were used for spectacles. Slowly but surely, microscopes were developed during the 16th and 17th centuries by Janssen, Cornelius Drebbel, and Metius, as well as Galileo who also invented the telescope. Other claims to the invention were made by Chomez, a Frenchman; Fontana; Divini; Schiener; and the Englishman, Robert Hooke, who wrote that he had peered through small globules of glass and beheld, 'Particles of bodies, very small.' Various improvements followed and in time microscopy became more and more accepted, and a popular subject.

Producing highly magnified 'views' of specimens which are so important in the study of certain subjects, there are countless uses. As a few examples, only, they can be used for the examination of fresh-water life; and that beneath seas, such as *protozoa*, a group

Heading photograph: Virus study via television. A general view of a BBC Studio, with the EM6B Electron Microscope in the background. Photo by courtesy of Associated Electrical Industries Ltd.

Left: The Microsystem 70 Research Binocular microscope with Kohler illumination. Photo by courtesy of W. Watson & Sons Ltd.



which constitutes the earliest animal life on earth as well as water plants such as diatoms and dismids. They are also used for examining specimens of land-plant life as moss, equisetum and spores, stalks of ferns, bread mould, water moulds, roots and seeds of plants, pollen, eggs of frogs, toads and other amphibians, foraminiferans, sponges—fresh-water and otherwise, linen, woollen, and cotton fibre, and hundreds of other things which normal eyes are unable to see.

A simple type of instrument such as a magnifying glass is one lens, but in a proper microscope two lenses are cemented with correct spacing into a small holder. The lower set closest to the object to be magnified is called the 'objective', and is placed permanently in the objective mount. That set closest to the eye, is the eyepiece or 'ocular.' The objective magnifies the object and sends the enlarged image up the tube to where the ocular picks it up and magnifies it again.

Therefore, one calculates the magnifying power of the objective. (Usually engraved on the metal mount, as for example—10x.) by the power of the ocular (Engraved next to the eye lens). If each has a power of 10x, the entire magnification power with this combination of lenses is 100x. Today, there is a standardisation of microscopes on this matter, although there has been much confusion in the past. Both of these lenses must work in exact harmony to produce a sharp, true view or 'picture.' In this way, the details of small objects are shown, this ability being known as 'resolving power' or 'resolution.'

Other important parts are the stage where specimens are placed, the eyepiece, mirror, body tube, and the principles are (1) To illuminate the object favourably, and (2) To move the lenses into the best position to obtain the clearest 'focus' (known as 'resolution'). Illumination is accomplished by transmitted light shining up through a transparent (or nearly so) specimen from below, or reflected light shining directly upon the object from sunlight or from a lamp. In this connection, microscopes with mains illumination as the light source are now obtainable for use at any time of the day.

Many interesting experiments with one or two magnifying glasses—even lenses from an old pair of spectacles may be used. With a single lens, determine (1) The focal length and (2) the focal point. See how the object is at first seen rightside up, and as the distance increases it 'turns over'. With lenses of different sizes, determine the focal point of each. Can you space the two in front of an object to produce a clear image through them both at once? It is easier in a darkened room using a candle or lamp as the object. Can you reverse the lenses and still produce an image?

The eye lens of the ocular may require cleaning often but far less often will it be necessary to lift out the whole ocular for cleaning the lower or field lens. The objective lens is the most important part and may now and then need a most careful cleaning, but in no circumstances should the objective mount ever be unscrewed or taken apart. Cleaning of these should be done with great care as even so hard a material as glass can acquire scratches. Besides the instrument itself, a certain amount of other equipment needed during experiment includes scissors, pipette and fine glass tubing, proper 'slides' for holding specimens, teasing needles and also forceps for handling specimens.

Various types of instrument can be bought to suit one's purpose, such as field microscopes for easy packing for work outside, dissecting microscopes permit the hands to be free while minute objects are being dis-

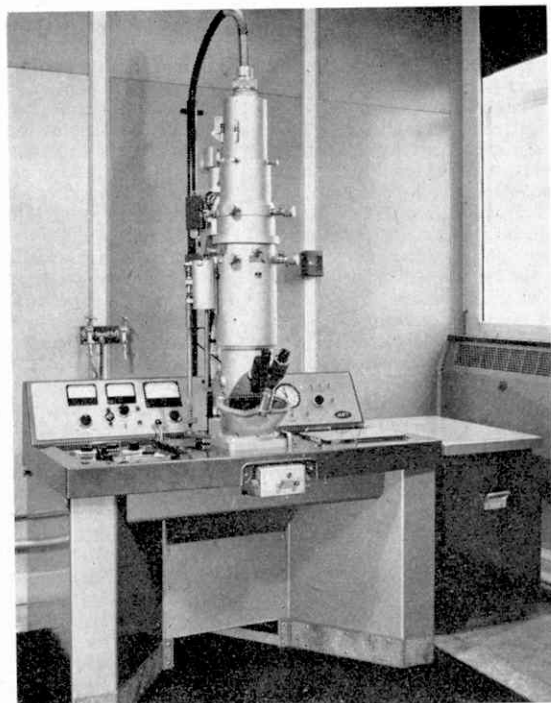

**Above:** A general view of the EM6B high resolution microscope. Photo by courtesy of Associated Electrical Industries Ltd.  
**Below:** The Microsystem 70 Student microscope with mains lighting. Photo by courtesy of W. Watson & Sons Ltd.

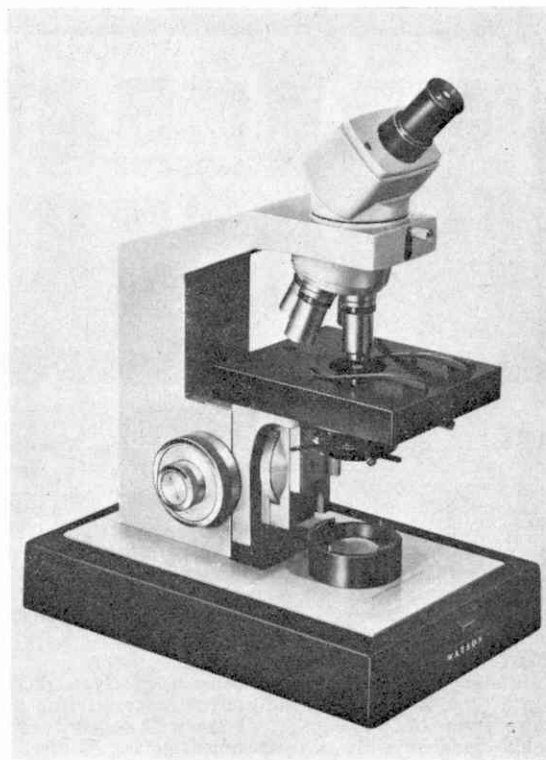

sected under close observation, petrographic instruments for use in metallurgy, and the binocular, and stereo, etc. Those making use of mains for illumination have been mentioned.

Many experiments may be carried out and one can find all about these by reading standard books on the subject. Viewing specimens is by no means the only object of using microscopes. Bacteria, for instance, require treatment with certain 'stains' and other chemicals in order to complete the standard tests laid down for their identification. Here again, besides the additional equipment, various chemicals as acetic acid, benzene, alum, epsom salts, etc., as well as 'stains' are needed in the different application and study of microscopy.

A much different instrument, known as the Electron microscope was developed by German scientists in the 1930's. This is built on an entirely different principle. Magnification with the ordinary light microscope is somewhat limited to about 2,000 diameters, but with the electron microscope selected objects can be magnified many times more. No lens is used, nor is there light. There is only a hole where the lens would be, surrounded by magnets or electromagnetic fields, which guide and focus a stream of electrons shot at the object.

The object itself is not placed in a glass slide, which at the standard 1.5 millimetres would be gigantically thick, but rather on a film of two-millionths of an inch in thickness. The stream of electrons are trained on a screen which the viewer watches, and which can reveal an image enlarged over 250,000 diameters. This can be photographed and still more enlarged. Although there are limitations to the kind of material

that can be examined, the electron instrument is the only one that can make possible the direct observation of such mysterious organisms as viruses.

The major differences between the ordinary light microscope and the electron type lie in the use of an electron beam instead of light, and the consequent replacement of glass lenses by those formed by certain configurations of magnetic or electric fields. Design of the instrument is largely determined by the need for a high vacuum to allow free movement of the electrons. The electron beam is produced by an Electron Gun similar to that used in a Cathode Ray Tube. The lens system, as in a projection microscope usually consists of a condenser lens to control the electron beam, an objective lens which is mainly responsible for the quality of the image, and a projector lens which produces further magnification.

The electron image is projected on to a fluorescent screen, where the electron energy is partly converted to light, making the image visible to the eye. Alternatively, the beam forming the electron image may be allowed to fall directly on a photographic film to make a permanent record. The instrument of demountable construction permits specimens and the photographic film to be readily inserted and removed from the vacuum.

A new type of instrument makes possible the televising of the image shown. This is the EM6B which transfers the image from the microscope to a television display unit, in the form of a transistorised monitor and image converter tube attachment. Besides bacteriology and the study of viruses, etc., the electron microscope has many more uses in modern industries such as ceramics, and textiles.

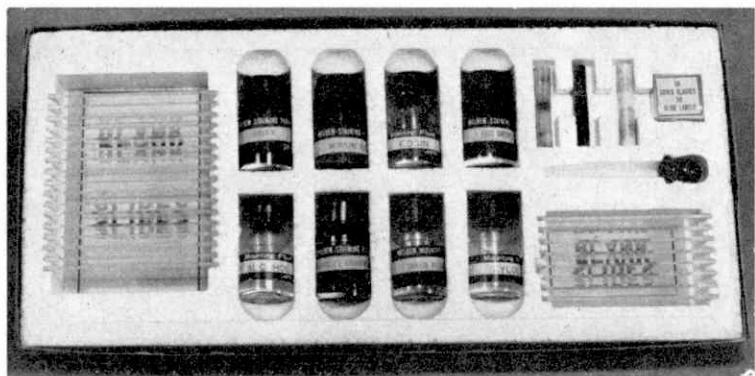

The "Milben" staining outfit

WE EXPECT most of you have, at one time or another, had a look through a microscope. Today they are common items in many schools, and can of course provide an interesting activity outside school hours. During recent years, the prices and availability of microscopes suitable for the amateur has improved tremendously, and we are devoting these pages to reviewing the products distributed by R. Kohnstam Ltd., who can be numbered as among the largest suppliers of microscopes and accessories.

#### Microscopes

Dealing firstly with microscopes themselves, there are no less than nine in the present range, varying in price from 28/- to 95/-. All are well finished and come complete with glass specimen slides. Naturally

## MICROSCOPE AND ACCESSORY REVIEW

the more expensive ones (apart from being rather more sophisticated than their cheaper counterparts), include additional items, and are supplied in small wooden cabinets. The accompanying photographs, should give a clearer indication of what the sets contain.

#### Prepared slides

In addition to the range of microscopes there are prepared boxes of slides, three in all and costing 9/11d. each. For your money you get in each set 12 glass specimen slides with various selected specimens sealed in. These are of course factory manufactured, and generally appear to be very well produced. Far better than most youngsters could achieve if they prepared them at home. The contents of the three outfits are described briefly below.

The outfit containing **Plant Specimens** includes a variety of spores, leaf sections and seeds. The **Animal**

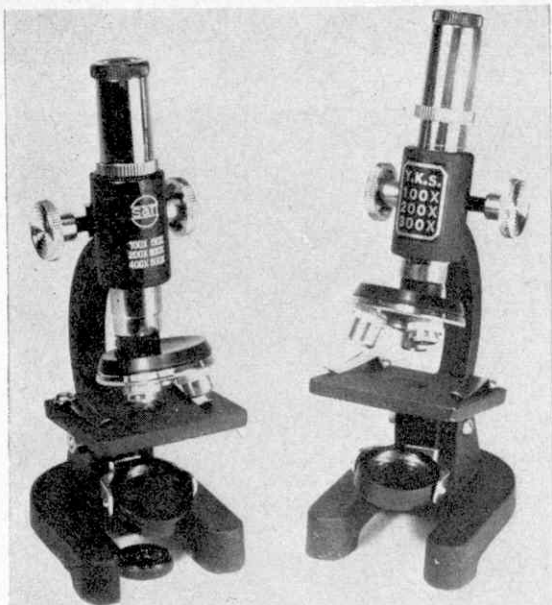

Two of the microscopes in the range. On the left the X100, X200, X300, X400, X500; 3 turret type costing 29/11, and on the right the X100, X200, X300 3 turret type costing 27/11.

Pack, marine life eggs, animal hairs and feather particles. The third and final pack, **Textile Fibres**, we found the most interesting to view, containing rayon, nylon and asbestos from the man-made fibres and cotton, jute, flax, etc., among the natural ones.

#### Accessory packs

Three accessory packs are available at 36/- each and contain the following:

**Staining Set:** This outfit contains 25 additional glass slides and 50 small glass plates for covering specimens on the above slides. In addition there are five various staining fluids and three mounting fluids. A small "dropper" is included in the outfit for easy removal and depositing of small amounts of the fluids.

**Slide Making Set:** This outfit, contained in a small wooden cabinet contains 25 glass slides, 50 glass covers, and 50 labels. In addition there are two bottles of staining fluid, one bottle of mounting fluid, a dropper, a glass rod and a needle probe.

**Brine Shrimp Hatching Set:** This rather unusual outfit contains minute Brine Shrimp eggs, and the necessary equipment to grow and observe them in various

The "Milben" slide making set.

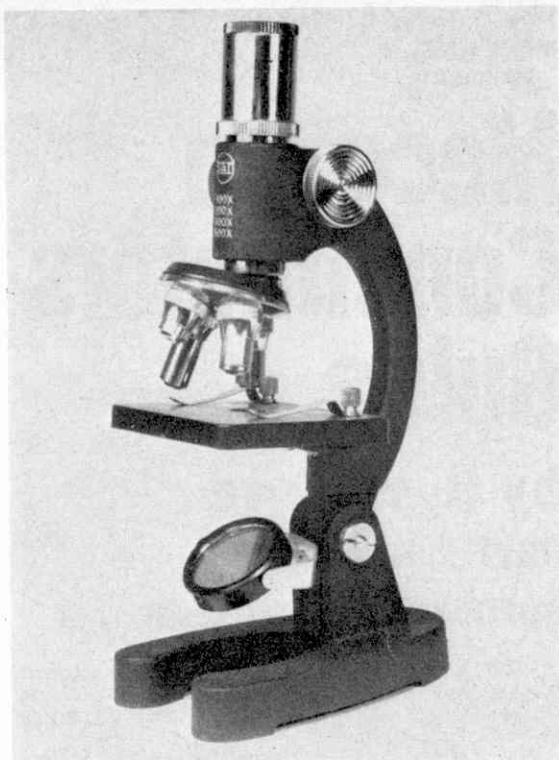

Above, the X100, X200, X300, X500, 4 turret type comes complete in a plastic case and costs 69/6.

stages of development.

A small plastic "hatchery" divided into small compartments allows eggs to be developed and observed in four stages of their growth. A small 50X pocket microscope is supplied for this. In addition there are of course shrimp eggs, sea salts and mounting fluid. Eight glass slides and 10 cover glasses are included and also 10 labels and a dropper.

The X100, X200, X300, 3 turret medium type complete with various tweezers, droppers, etc., costs 79/11.

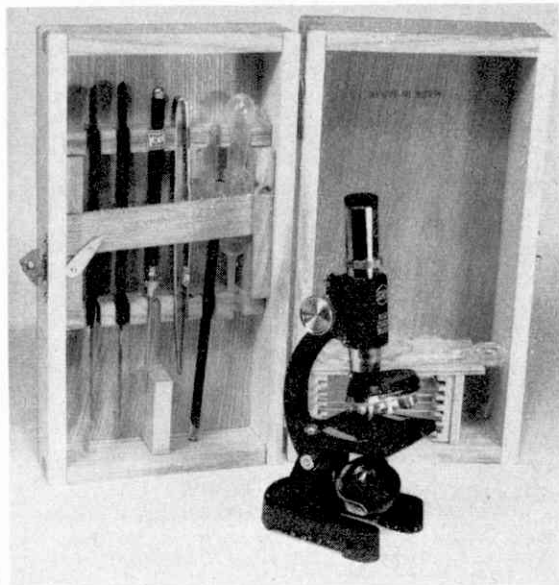



# Meccano Constructors Guide

## by B. N. Love Part 2 – Pulleys, sprockets and gears

**A**CTION MODELS invariably have the greatest attraction for Meccano enthusiasts of all ages and this chapter deals with some of the aspects of putting Meccano models in motion.

Wheels and axles were among the earliest components in the system and a simple range of gears and sprocket wheels followed shortly after the inception of "Mechanics Made Easy", the forerunner of Meccano, more than half a century ago. The family of Pulleys illustrated in Fig. 1, vary very little from

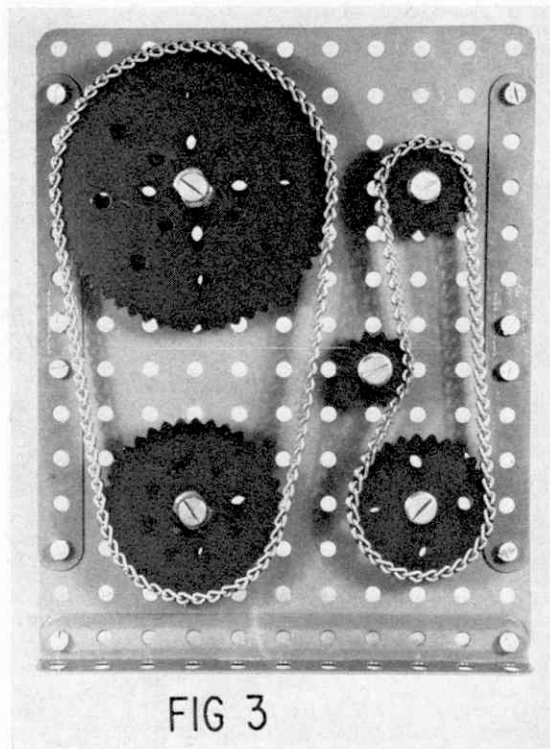

FIG 3

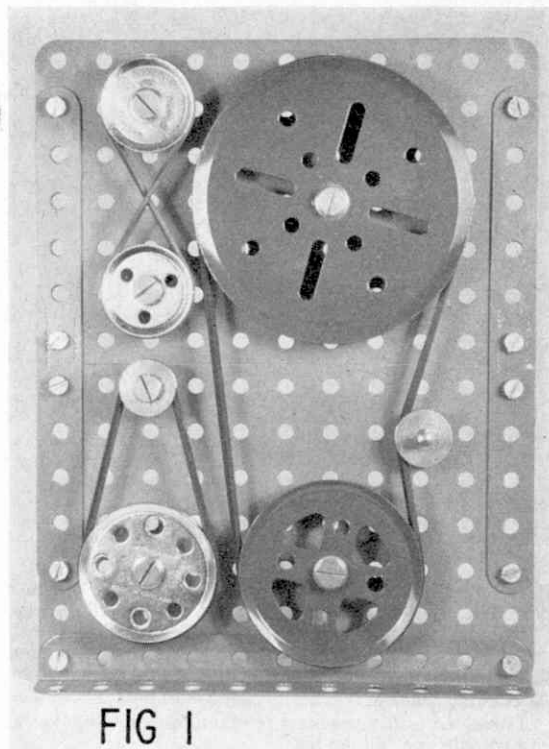

FIG 1

their original design and give a range of diameters from  $\frac{1}{2}$  in. to 3 in. When used with an equally wide range of Meccano rubber Driving Bands, a large number of pulley ratios are obtainable. Both the  $\frac{1}{2}$  in. and 1 in. Pulley are available with or without boss but where no boss is fitted, the Pulley is described as "loose" and is used principally as a guide pulley in cord hoisting mechanisms or for making up multi-sheave pulley blocks.

Considerable power may be transmitted by Meccano Pulley drives which may be reinforced by using a system of twin Pulleys and double Driving Bands. An example of this is shown in Fig. 3, where Pulleys are successfully used in conjunction with a gear-box to transmit motion to a sophisticated model of a self-programming Fairground model. There is plenty of scope, both in simple and more advanced models for the use of pulley drives and the rubber Driving Bands give excellent latitude in tensioning and positioning of their respective Pulley Wheels. These Bands are manufactured in "light" and "heavy" gauge to suit individual power requirements.

When calculating pulley ratios, the diameters of the various Meccano Pulleys may be taken as an approximate guide so that a 1 in. Pulley driving a 2 in. Pulley will give a step down ratio of 2 : 1, but the belt drives in general have the disadvantage of stretching which can, in turn, cause slipping or "creeping" of the driving belt. Ratios must therefore be considered to be approximate.

Fig. 1. The basic gauge of Meccano Pulley Wheels. The  $\frac{1}{2}$  in. Pulley without boss acts as a "jockey" pulley to increase belt tension. The twisted belt provides a reverse drive.  
Fig. 3. The basic range of Meccano Sprocket Wheels.

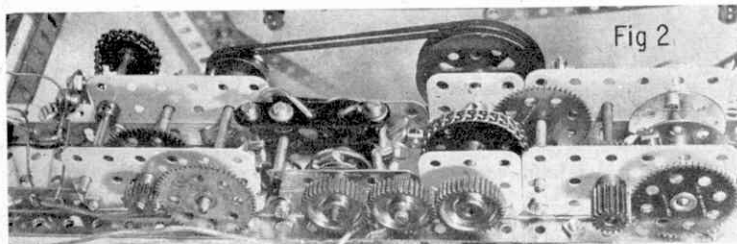
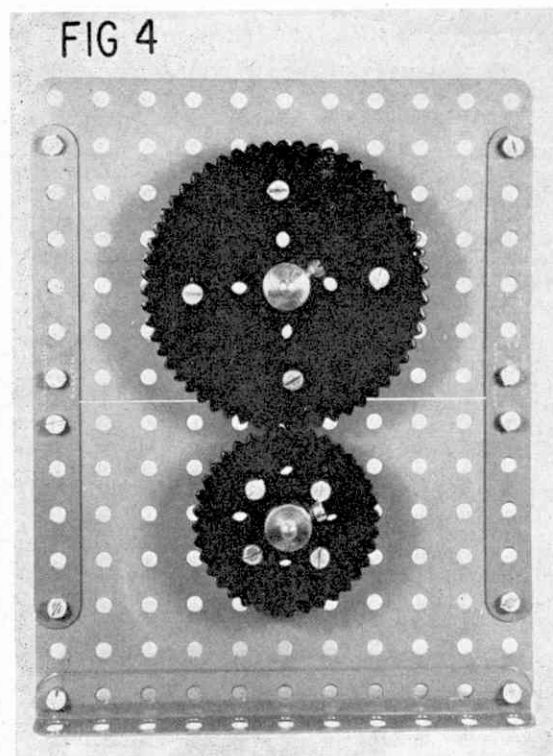
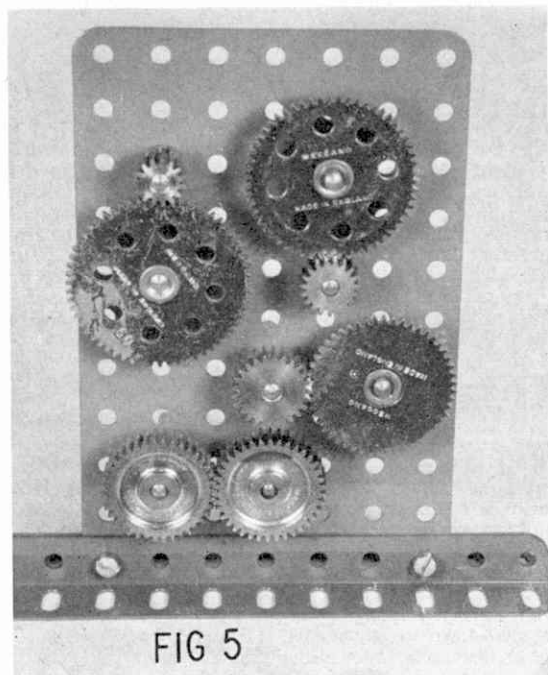

Fig. 2. Pulleys, sprockets and gear wheels in combination to operate an accurate programming mechanism. Fig. 4. Meccano Sprocket Wheels paired-up to give direct meshing as heavy duty spur gears. Fig. 5. Range of pinions and gear wheels giving four different ratios ranging from 1:1 to 4:1.

Where it is important that a mechanism must have its various movements running in step, or "synchronised", the role of the pulley drive may be taken over by Meccano Sprocket Wheels and Sprocket Chain. Since the Sprocket Wheels are cut with similar tooth forms and are available in directly related ratios, it is a simple matter to employ them for driving widely separated shafts with a guarantee of accurate timing. Fig. 3 shows the basic range of Sprocket Wheels available, but it is important to remember, here, that, while the diameters of the parts can be used as a guide in calculating Sprocket ratios, the exact ratios can only be determined by the number of teeth each part has. For example, the diameter system indicates that a 1 in. Sprocket driving a 3 in. Sprocket results in a ratio of 3:1, whereas, the exact ratio is 56:18 or slightly more than 3:1. Generally speaking, therefore, diameters are more a guide to the spacing of shaft centres, while teeth numbers enable ratios to be calculated accurately.

It is not generally realised by Constructors that Part No. 168b, Ball Thrust Race Toothed Disc, 4 in. dia. is also a useful sprocket wheel when bolted to a Bush



Wheel or similar centre. Furthermore it has the peculiar number of 73 teeth. By arranging for this Toothed Disc to be engaged by a rotary shaft carrying a Fork Piece radially mounted, the 73-toothed Disc can be advanced one tooth at a time. If, in turn, its own shaft drives a 5:1 reduction ratio, an overall ratio of  $73 \times 5 = 365$  is obtained. This should be of great interest to clock builders, being a very simple method of recording a complete year's calendar movements!

A further unorthodox feature of the Meccano Sprocket system is that Sprocket Wheels may be directly engaged as coarse-toothed gears and, by bolting them in pairs, a substantial area of tooth meshing surface is obtained together with rugged drive properties and an excellent reproduction of "period" gearing reminiscent of the days of the great engineers Matthew Boulton and James Watt in the early Industrial Revolution. Fig. 4 shows an example of such an arrangement. As all Sprocket Wheels of 1½ in. diameter or greater are perforated with radial holes, they serve very well as hub centres for heavy rotating structures and as the 2 in. and 3 in. Sprockets have heavy duty brass bosses they are capable of supporting very stout structures.

For a high degree of precision and an infinite range of ratios the Gear Wheels and Pinions in the Meccano system may be employed with the utmost confidence.

FIG 6

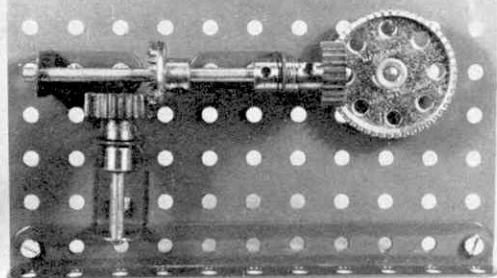

Fig. 5 shows a few simple arrangements of Gears with standard spacing in ratios suitable for general model building. These are calculated in each case by noting the *numbers of teeth* (not diameters) and making a fraction from the two numbers obtained from any meshing pair. If the arrangement is used to obtain increased speed (with resulting reduced power, or "torque"), it is known as a step-up ratio, one example of which is a 50-teeth Gear Wheel driving a 25-teeth Pinion, the step-up ratio being  $50/25$  or  $1:2$ . If the Pinion drives the Gear Wheel, a step-down or reduction ratio (with increased torque) is obtained, in which case the ratio would be  $2:1$ .

As the Constructor advances in his model building techniques, gear ratios will become more important and if an accurate timing device is required in a particular mechanism, a sound knowledge of the required ratios is essential. It is a common error among novice builders using gear drives for the first time to *add* gear ratios when there are several rotating shafts in a gear-box. This is wrong, of course, as the action of one gear ratio driving a second or third, is to *multiply* the ratios in step up arrangements and to *divide* them in step-down arrangements. Referring back to Fig. 2 as an example, the pulley shaft carries a 19-teeth Pinion meshing with a 57-teeth Gear to give a first stage reduction of  $3:1$ . Next, a 25-teeth Pinion passes on the drive to a 50-teeth Gear Wheel, giving a second stage reduction of  $2:1$  and, finally, a long-faced 19-teeth Pinion transmits the drive to a 57-teeth Gear Wheel giving a third stage reduction of  $3:1$ . Putting these three ratios in combination we now get  $3 \times 2 \times 3 = 18$  so that the whole gear train in this case gives

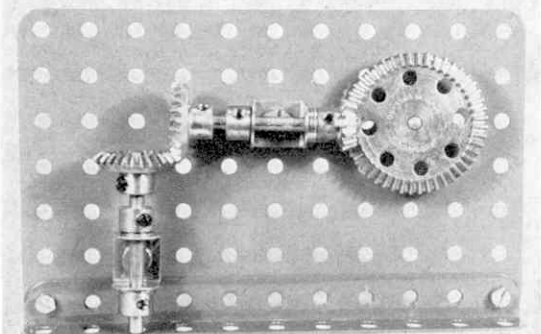

FIG 7

a reduction ratio of  $18:1$ .

The gear arrangements shown in Fig. 5 are all mounted on shafts set in bearings which are spaced 1 in. apart and provide ratios from  $1:1$  down to  $4:1$ . Gear diameters are quoted on the official parts list and, generally speaking, if the diameters of a pair of meshing gears are added and then divided by 2, the centre distance of the driving shafts is obtained. However, in the case of the Pinion, Part No. 26c, and the Gear Wheel, Part No. 27d, which combine at 1 in. spacing to give a ratio of  $4:1$ , the sum of the diameters is  $2\frac{1}{8}$  in. and when this is halved, the result is  $1\frac{1}{16}$  in., but the discrepancy is not sufficient to effect the smooth meshing of these two gears at 1 in. spacing. Larger ratios are obtainable directly by meshing the 19-teeth Pinion with the  $2\frac{1}{2}$  in. or  $3\frac{1}{2}$  in. Gear Wheel, when ratios of  $5:1$  and  $7:1$  respectively are obtained.

All of the foregoing gears are known as "spur" gears and are of simple tooth form meshing together on parallel shafts.

To effect a change of direction in gearing requires the use of gears which have their teeth turned at an appropriate angle. The simplest form of such a gear in the Meccano system is the Contrate Wheel illu-

FIG 8

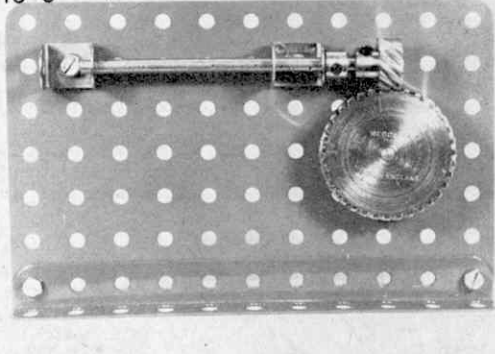

strated in Fig. 6. Two sizes are available, namely the  $\frac{3}{8}$  in. diameter 25-teeth and the  $1\frac{1}{2}$  in. diameter 50-teeth Contrate Wheels. When meshed with 25-teeth Pinions as shown, they provide  $1:1$  and  $1:2$  ratios respectively. They can, of course, be meshed with other Pinion sizes to provide other ratios, calculation again being done simply by comparing teeth numbers.

A development of the contrate is the bevel gear and this is also available in the Meccano system following standard engineering practice. Bevel Gears give a much stronger and quieter drive than Contrate Wheels owing to the careful formation and meshing of the teeth to provide a drive at right-angles. They are assisted in their performance by the fairly wide surface contact of teeth provided. One pair of Bevel Gears, Part No.'s 30a and 30c are designed to be used as a matched pair as the teeth angle of the larger gear is cut to complement that of the smaller. As they have 16 teeth and 48 teeth respectively, they provide a  $3:1$  ratio. Part No. 30, the  $\frac{7}{8}$  in. Bevel Gear has 26 teeth cut at an angle of  $45^\circ$  and is used with a second Bevel Gear of the same size to provide a strong right-angle drive with a  $1:1$  ratio. These are illustrated in Fig. 7.

Fig. 6 Contrate drive giving two changes of direction and  $2:1$  gear reduction. Fig. 7. Bevel gearing giving two changes of direction and  $3:1$  reduction. Fig. 8. Helical drive giving right angle change of direction with axes mounted in different places.



Perhaps the most interesting Meccano gears are the pair of Helical Gears, Part No.'s 211a and 211b. Motion through Helical Gears is transmitted by a cross-sliding action and the teeth are cut with a twisted curve so that the faces of a meshing pair are at right-angles. Accurate location of shafts driven by Helical Gears is essential if smooth action is to be obtained, but when properly set up and lightly lubricated, they provide a very smooth chatter-free and almost silent drive. Although designed as a matched pair, the smaller of the Helicals can be meshed with one of its own kind to give a 1 : 1 ratio, but some adjustment in standard spacing between the right-angle shafts is necessary to achieve this. When the normal pair, 211a and 211b are used, the ratio is approximately 1 : 3 although, in practice, they do not give an exact whole number ratio, counting the teeth. A helical drive is shown in Fig. 8.

When taken to its logical conclusion, a helical drive becomes the Worm and Pinion arrangement shown in Fig. 9. The Worm Wheel has a helix or "pitch" such that one revolution of the Worm will produce a movement in its driven Pinion equivalent to the distance of one tooth width. This makes gear ratios very simple to calculate since it is necessary to know only the number of teeth on the engaged Pinion or Gear Wheel. Hence, when meshing with the  $3\frac{1}{2}$  in. Gear Wheel, the worm will provide a reduction ratio of 133 : 1.

While the Meccano Helical Gears may be driven in either direction the Worm cannot be "back-driven", i.e. turned by the Gear Wheel with which it is meshed. This has some disadvantages but they are few and are outweighed by the advantage that a Worm drive provides its own brake so that, when employed in crane winding drums, etc., the moment power to the Worm shaft is stopped, the load will not be able to overdrive the worm because of the non-reversible nature of the Worm's helix.

Gear arrangements illustrated so far are simple ones, but when built into compound gear trains or gearboxes, they open up the Meccano system to its fullest extent, and the versatility of the Meccano system is limitless. Once the constructor has experimented with simple reduction gears in working models, gear changing and reverse mechanisms follow as a natural development. A very simple two-speed gearbox is illustrated in Fig. 10. The shaft receiving the drive from a hand wheel, clockwork or electric motor, etc., is known as the "input" shaft and the final shaft passing on the motion to the model movements is known as the "output" shaft. In Fig. 10 the input shaft (a) carries two Pinions of different sizes, while the output shaft (b) carries two different Gear Wheels to mesh with their respective Pinions, as required. A long-faced Pinion is secured to one end of the output shaft, which is free to slide in its bearings, being moved by a simple gear shift lever. It is important that one pair of gears is completely out of mesh before the second pair engages, or the mechanism will jam. The purpose of the outside Pinion is to provide a take-off point for additional gearing, its long face allowing the output shaft to slide through a distance adequate for gear changing.

It is sometimes convenient to use a similar arrangement for the simple purpose of reversing the drive from the output shaft. In this case, a 1 : 1 reverse drive can

Fig. 10. A simple form of two-speed change-over gearbox. The input shaft (a) receives the drive via its Sprocket Wheel which is then passed on to either of the two Gear Wheels on the output shaft (b) by means of the gear shift lever (c) which is pivoted by a lock-nutted Bolt to the 1 x 1 in. Angle Bracket and carries a Bolt engaging between the two central Collars on the output shaft.

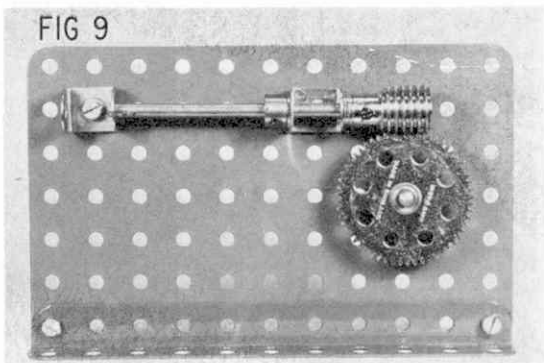
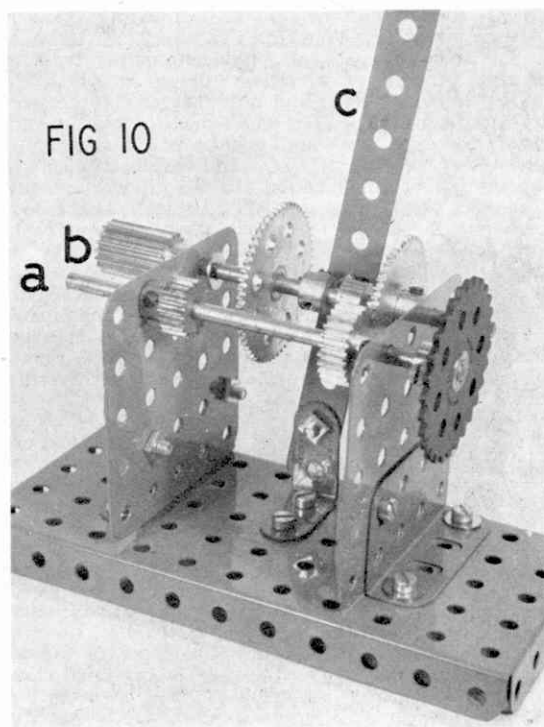

Fig. 9. A Worm drive, considered to be the final development of a helical drive.

be achieved by making one pair of gears from 1 in. Gear Wheels and inserting an intermediate gear known as an "idler" between a pair of Pinions at the other end of the gear change shaft. To keep the shaft spacing correct, three 19-teeth Pinions are used "in line", the centre Pinion being secured to the side plate of the gearbox by a 1 in. Bolt on which it is free to rotate or "idle". Its purpose is to pass on the rotation of the input shaft to the output shaft in the same direction, the reverse drive being effected by the pair of 1 in. Gear Wheels, when meshed at the other end of the shafts.

Next month, I will continue to explain the uses of Meccano Gears, and then combine the basic points outlined in the first two parts of this series and deal with crane structures.



**Michael Lorant**  
explains the  
workings and  
use of this  
amazing



## GIANT MODEL OF INFLAMMATION

SCIENTISTS OF The Upjohn Company in the United States, have recently worked out medical and related scientific details of a giant and massive new model of a microscopic portion of the human blood vessel and circulatory system depicting inflammation, one of the body's most basic and least understood processes. It has been shown to physicians attending the recent annual meeting of The American Medical Association in New York City.

The unusual model of inflammation is a twisting, soaring network of plexiglass tubing in which the tiniest of blood vessels and cells they contain are seen 25,000 times lifesize. The whole model, a 35-foot-wide by 15-foot-high structure, represents a fiftieth of an inch patch of human tissue and vividly depicts the acute phase of inflammation. In this process, a virtual war takes place in the small blood vessels, as the body mobilises its defences—various types of blood cells and potent chemical enzymes—against disease or injury. It shows the complex chain of cellular events broken down into eight major steps which take place inside gigantic, transparent blood vessels, illuminated by multi-coloured, self-contained lights. A simultaneous 13-minute film illustrates the process with photomicrographs and time-lapse cinemicroscopic of actual blood vessels.

In total, the unique model contains 969 feet of curved, transparent plexiglass tubing, ranging from one and one-half to three feet in diameter, representing the tiny veins, or venules. Normal red and white blood cells—scavenger leukocytes, lymphocytes and other forms—are blown up to six- to eight-inch dimensions and change in shape and function as the inflammatory process proceeds. Weaving throughout the model are 2,120 feet of aluminium rods representing strands of connective tissue, largely collagen, the main supportive protein of skin, tendon, bone and cartilage.

The viewers see the explosive sequence of inflammatory events begin with the cells in a normal state, in a three-foot-wide venule at the left of the model. As bacteria symbolically invades the tissue, destructive

enzymes are released, damaging the vessel walls themselves and causing gaps through which scavenger cells—leukocytes—escape to attack and digest the invading bacteria.

At this stage, the inflammatory process itself becomes destructive. Extraordinary powerful enzymes, released by tiny intracellular bodies called lysosomes, not only attack the foreign body but the host tissue itself; hence, the term "suicide sacs" applied to the lysosomes. The result: the pain, redness, heat and swelling associated with inflammation.

But as the model shows, defences come into play after this period of apparent self-destruction. Other cells appear: macrophages digest blood clots and other waste materials; fibro-blasts produce new collagen to rebuild tissue; capillaries form new channels to carry blood to the inflamed area. The healing process is underway.

Medical and scientific research work of the model were co-ordinated by Dr. A. G. MacLood, research scientist of The Upjohn Company, which in its own laboratories and through support of outside research is seeking answers to the cause and control of inflammation.

Scientists throughout the world are studying inflammation, as more knowledge and understanding of it could lead to major breakthrough in medicine. One of the most perplexing problems is the difference between acute inflammation—basically a normal, defensive process—and chronic inflammation, when the body forgets to turn off the tap and the inflammatory process perpetuates itself.

Chronic inflammation is at the root of some of mankind's most painful and pervasive diseases—rheumatoid arthritis, rheumatic fever, hemolytic anemia, to name only a few. Understanding the relationship between inflammation and immunologic reactions also may remove the stumbling block of rejection and permit widescale use of organ and tissue grafts.

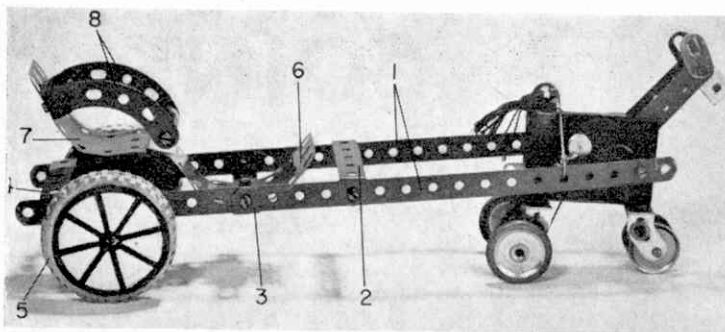

# SIMPLE WHISKY CART

by Spanner

IN THESE days of fast cars and high-speed travel, we tend to look back on the era of horse-drawn vehicles, with pity for the people living at the time. Not for them, we think, was there the carefree enjoyment of the modern "sporty set", the exhilarating thrill of roaring along country lanes in a low-slung powerful sports car; the hood down and the slipstream buffeting cheeks to a healthy glow. No. Not for them the pleasure of road travel, but rather the painful endurance of an extremely uncomfortable journey in a large, unwieldy and badly-sprung carriage or else the monotonous jogging of a pony and trap.

It shows you how wrong we can be! Admittedly we, today, may have the best of it, but there was still a very active "sporty set" in the days of the horse and there were plenty of "sporty" vehicles about. Not least of these was the "whisky"—a little one-seater job; very light with open bodywork, long shafts and drawn by a single, high-stepping horse. This could fairly dash along and might well qualify as the sports car of a century ago. Featured here is a really simple Meccano model of the whisky built from a No. 4 Outfit. Drawn by its own "horse", built around a Magic Clockwork Motor, it is ideal for younger builders to have a shot at.

Dealing first with the whisky, itself, the chassis and shafts consist of nothing more than two  $12\frac{1}{2}$  in. Strips 1 connected in the positions shown by three  $2\frac{1}{2} \times \frac{1}{2}$  in. Double Angle Strips 2, 3 and 4, the Bolts fixing Double Angle Strip 4 to the Strips also helping to fix two  $2\frac{1}{2}$  in. Stepped Curved Strips in place. Journalled in the centre holes of these Curved Strips to complete the chassis is a  $3\frac{1}{2}$  in. Rod held in place by  $2\frac{1}{2}$  in. Road Wheels 5.

Equally as simple in construction as this is the body which consists of nothing more than one  $2\frac{1}{2} \times 1\frac{1}{2}$  in. Flexible Plate 6 shaped to form the footboard, and one  $5\frac{1}{2} \times 1\frac{1}{2}$  in. Flexible Plate 7, shaped to form the seat. Both Plates are bolted to Double Angle Strip 3. Secured to Plate 7 is a  $1\frac{1}{2} \times \frac{1}{2}$  in. Double Angle Strip, to the lugs of which another two  $2\frac{1}{2}$  in. Stepped Curved Strips 8 are bolted. The free ends of these Curved Strips are also attached to Flexible Plate 7, in this case by Angle Brackets.

As far as the horse is concerned, this is supplied mainly by the Magic Motor, to which two  $2\frac{1}{2}$  in. Strips 9 are bolted to serve as the neck, a further two  $2\frac{1}{2}$  in. Strips 10 to represent the left fore and hind legs and two Angle Brackets extended by Fishplates 11 to serve as the remaining legs. Journalled in front Strip 10 and Fishplate 11 is a  $1\frac{1}{2}$  in. Rod carrying, in order,

Above: Meccano Set No. 4, plus a Magic Motor, is all that is needed to build this little horse and cart model—"the sports car of a century ago." Right: A close-up view of the "horse" used to pull the "Whisky." The Magic Motor serves as the horse's entire body, as can be seen.

three Washers, a 1 in. Pulley with boss 12, a Spring Clip, a 1 in. Pulley without boss 13 and a final Washer. The Spring Clip and Pulley 12 hold the Rod in place.

A 2 in. Rod is journalled in rear Strip 10 and Fishplate 11, this Rod carrying a 1 in. Pulley with boss 14 and being held in place by two similar 1 in. Pulleys, each of these being fitted with a Rubber Ring 15. Pulley 14 is connected to the drive pulley of the Motor by a 6 in. Driving Band.

Finally, the head and ears, respectively, are supplied by a  $1 \times \frac{1}{2}$  in. Double Bracket 16 and two Fishplates 17, while the tail is represented by several short lengths of Cord tied to an Angle Bracket 18 bolted to the upper rear corner of the Motor. The completed horse is hitched to the whisky by Cord tied between this Angle Bracket and Strips 1.

As a matter of interest, the accompanying photographs give the impression that the model is fitted with spoked wheels. This effect was obtained by marking the spokes and rims with a felt-tipped pen on white paper discs and then sticking the discs on the face of the Road Wheels. It's easy and looks realistic.

## PARTS REQUIRED

2-1	1-17	32-37b	1-186
4-5	1-18a	12-38	2-187
4-10	4-22	1-48	1-188
1-11a	1-22a	3-48a	1-189
7-12	1-35	4-90a	1-Magic
1-16	31-37a	1-155	Clockwork
			Motor.

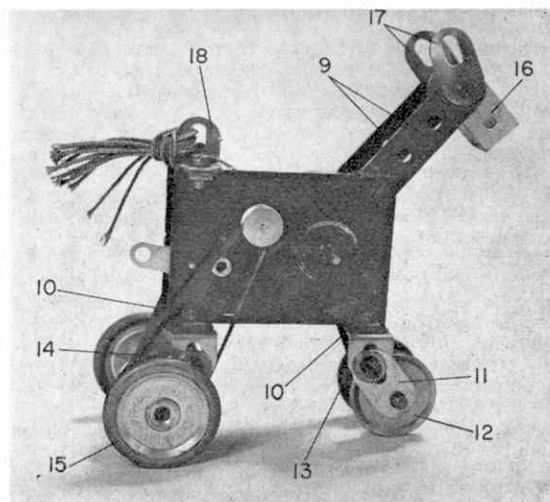





# COINS on STAMPS

by  
**James A. Mackay**

COIN COLLECTING is becoming increasingly popular nowadays, with impending decimalisation stimulating interest in this hobby. If the present rate of growth is maintained experts estimate that numismatics (the science of coin-collecting) will overtake stamps by the end of the 1970s. In the meantime, however, there are many collectors who combine interest in stamps with coins and one of the ways in which this can be done is to collect stamps which depict coins on them.

Great impetus to this theme has been given by the stamps issued since the beginning of October last year when Guernsey's postal services became independent of the G.P.O. The definitive series features the sculptured profile of the Queen (as shown on current British stamps) but each stamp also depicts the profile of a previous British monarch based on coins issued during their reign. The very crude effigies of the early kings, such as Edward the Confessor, William the Conqueror, Henry II and Henry V, were taken from silver pennies, the standard coin in England from the seventh century onwards. Though pennies have not been struck in silver for everyday use since the reign of Charles II (1660-85) it is interesting to note that silver pennies are still minted for the annual Maundy Thursday ceremony and these are (theoretically at least) legal tender. Presumably after Decimal Day in February 1971 the Maundy series of silver 1d., 2d., 3d. and 4d. will cease to exist. Britain has already lost two coins as a result of decimalisation and both have left philatelic mementoes. The demise of the halfpenny last June was marked by a special postmark used, appropriately enough, at Halfpenny Green post office. A commemorative postmark was also used on December 31 to mark the passing of the halfcrown.

Coins have been depicted on the stamps of many countries, the earliest of these to do so being several of the Australian states. New South Wales had a 5s. stamp, from 1863 to the end of the century, which showed the obverse (heads) of the famous Gothic crown, so-called on account of the style of lettering used. Both Victoria and Tasmania issued postal fiscals

(stamps primarily intended for revenue purposes but valid for postage) showing contemporary British coins. Victoria showed penny, groat (4d.) and florin designs on its stamps while Tasmania depicted the reverse (tails) of the crown and sovereign. This showed St. George and the Dragon, a splendid design engraved by Benedetto Pistrucci in 1816 and used for most of the crown and gold coins of Britain from that time to the present day. The model for St. George is said to have been a waiter at Brunet's Hotel in Leicester Square, London, where Pistrucci had lodgings!

The St. George and Dragon reverse design also appeared on the 5 drachmae stamps issued by Crete in the early years of this century. St. George was the patron saint of the Cretans and since the stamps were printed in England this probably explains why the British coin was the inspiration of the design. Other stamps in the series, however, featured ancient coins minted by the city states which flourished in Crete centuries before the Christian era.

Greece is proud of her numismatic heritage, coins having been in use in that country since the seventh century BC. It is not surprising, therefore, to find ancient coins reproduced on many Greek stamps. An Amphictyonic coin of the fourth century BC appeared on the 40 lepta stamp in the pre-war definitive series while the other side of the same coin was the subject of a stamp issued in 1954 to mark the fifth anniversary of NATO. The ancient coins, with their mythological figures, have served as models for many modern Greek coins. One of the stamps illustrated here, for example, shows Demeter, goddess of corn—from the 10 drachmae coin of 1936 and not the pre-Christian original. Appropriately this stamp commemorated the Freedom from Hunger campaign of 1963. In recent years Greece has issued two long sets devoted to ancient coins, featuring both obverse and reverse of each one. Cyprus and Italy have also issued stamps depicting ancient Greek coins, while France's precancelled series in current use features a crude parody of the gold stater of Greece, minted by a Gaulish prince in the first century BC.

Tunisia, which in classical times was the site of the Phoenician empire of Carthage, has shown Carthaginian coins on its stamps, while in recent months, neighbouring Morocco has depicted several ancient Arab coins. The most prolific issuer of stamps featuring coins, however, is Israel whose definitive issues from 1948 onwards have reproduced shekels and drachmas from the times of the first and second Jewish Revolts. Both Yugoslavia and Bulgaria have recently issued sets showing coins from the period when these countries were under Byzantine influence.

Two of the most popular coins with collectors at the present time have also been featured on stamps: the Kennedy half dollar, on a stamp of Nigeria and the Churchill crown, on a stamp from the Kathiri State of Seyun in South Arabia.

There have even been stamps embossed in metal foil to resemble the coins shown on them. The first of these circular curiosities came from Tonga in 1963 to commemorate the introduction of the first gold coinage in Polynesia. Subsequently circular coin stamps have been released by Bhutan, Sharjah, Sierra Leone, Qatar and Umm al Qiwain. The Bahamas recently introduced gold coins and released a set of four "bean-shaped" stamps on gold surfaced paper depicting obverse and reverse of each coin. The ultimate in coins on stamps, however, was a luxury miniature sheet from Paraguay in which gold-plated facsimiles of actual Papal gold coins were affixed to the stamps, to commemorate the Eucharistic Congress in 1964.

**Our young Italian 'Simple Model' expert, Gianguido Servetti, has designed yet another fascinating model**

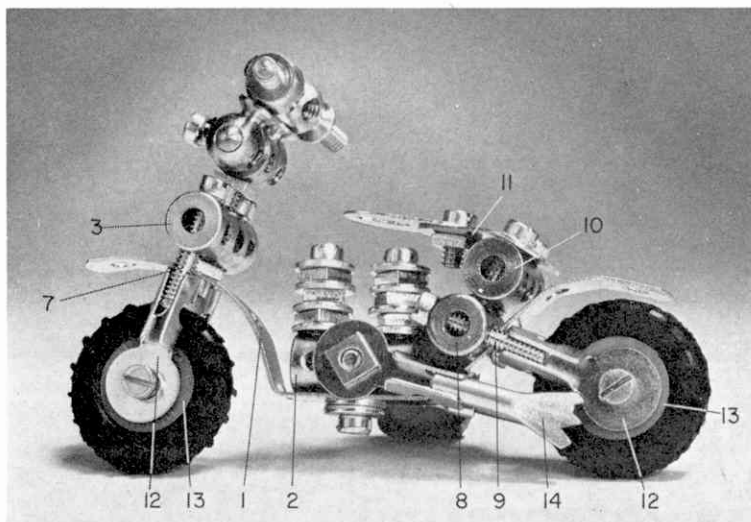

# SIMPLICITY SCOOTER

## Described by Spanner

**S**IMPLICITY MODELLING is a branch of the Meccano hobby that appeals to all. In all my years with Meccano, I have yet to meet anybody, either inside or outside the hobby, who has not shown genuine interest at sight of one of these delightful little constructions; constructions which use very few parts and yet which capture the true atmosphere of the subjects on which they are based. We, on *Meccano Magazine*, have always been captivated by them and have featured them regularly in the M.M. ever since the magazine was first published. The last one, a Moon Bug, appeared only two months ago, but this does not prevent us from featuring another one here—which we do! It's a minute Motor Scooter designed by the builder of the Moon Bug, 12-year-old Gianguido Servetti of Piacenza, Italy, and it makes excellent use of the few parts it incorporates.

The mainframe and mudguards consist of no more than a 4½ in. Narrow Strip 1, bent to shape, as shown. Bolted to the centre of the Strip is a Coupling 2, in the

end transverse smooth bores of which two ¾ in. Bolts are held by Grub Screws. Fixed on each of these Bolts to represent cylinders are four Washers, interspaced by three Nuts.

Also secured to Strip 1 through its second hole from the front is another ¾ in. Bolt, onto the shank of which a second Coupling 3 is screwed, the Bolt passing through the centre tapped bore of the Coupling. Locked by a Nut on the end of the Bolt is a Collar, in which a 1 in. Rod is held by a standard Bolt 4, this Bolt also serving to represent the headlamp. Two Handrail Supports 5 are secured one on each end of the 1 in. Rod, a further Handrail Support 6 being mounted on the shank of each of the first Supports to complete the handle-bars. Two ¾ in. Bolts 7 are held by Grub Screws in the end tapped bores of Coupling 3.

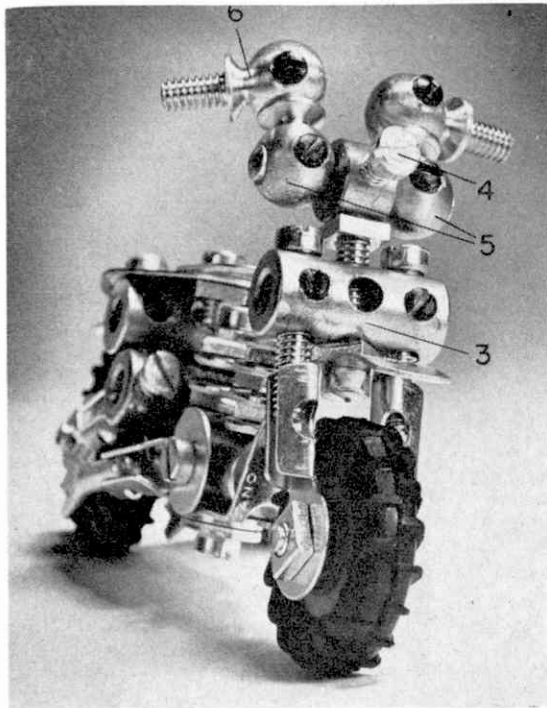

It's surprising how realistic a little model can appear even though it is built with only a few simple parts. This delightful Scooter was designed by 12-year-old Gianguido Servetti of Piacenza, Italy. The interesting shape of Guido's Scooter is well illustrated in this frontal view of the model.

Next, a third Coupling 8 is bolted to Strip 1 through its third hole from the rear end, the fixing Bolt being screwed into the centre tapped bore of the Coupling. Held by Grub Screws in the end smooth bores of the Coupling are two further  $\frac{3}{8}$  in. Bolts 9, while another Coupling 10 is secured to Coupling 8 by two  $\frac{1}{2}$  in. Bolts screwed into the Couplings' end tapped bores, these Bolts also fixing a 1 in. Triangular Plate 11 to Coupling 10. The Triangular Plate is extended forward by a Fishplate to serve as the seat.

Both front and rear forks are now supplied by Rod and Strip Connectors 12, mounted on the protruding shanks of Bolts 7 and 9. Held by Nuts in each pair of Connectors is a  $\frac{1}{2}$  in. Bolt, on which a  $\frac{1}{2}$  in. loose Pulley 13 is mounted, this Pulley being fitted with a suitable Dinky Toy tyre to increase realism. The tyres on the model illustrated are No. 093 as fitted to the Euclid Rear Dump Truck, No. 965.

Last of all, twin exhaust pipes are supplied by two Centre Forks 14 held in two more Rod and Strip Connectors bolted to Coupling 2, the Bolt passing through the centre smooth bore of the Coupling.

**PARTS REQUIRED**

1—10	4—37b	2—65	4—136
1—18b	10—38	1—77	6—212
2—23	1—59	7—111	1—235d
13—37a	4—63	5—111a	2—Dinky Toy tyres 093

**Spanner describes  
an interesting  
working model of  
a conveyor . . .**

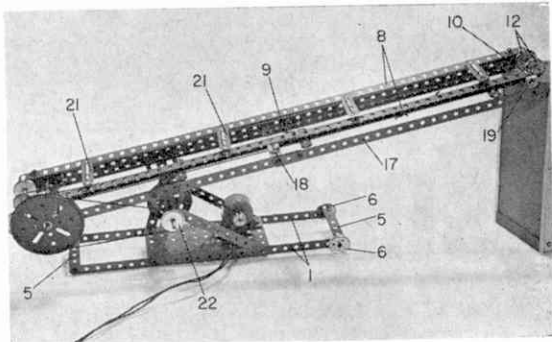

# ELEVATOR LOADER

An Emebo Electric Motor supplies the power for this interesting Elevator Loader, built with Meccano Set No. 5.

OF ALL the larger labour-saving machines in existence today, one of the most widely used is the elevator loader. These are found not only in all branches of industry, but also in agriculture where they are particularly useful for such things as building hay bales into stacks and so on. The loader most favoured by farmers for this sort of work is the motorised conveyor type, on a mobile mounting designed to be



**A close-up view of the loader mounting showing the Emebo Motor and drive system.**

wheeled into position by hand, and with a free rising conveyor unit which can be raised to the desired angle and rested on the edge of the stack being built. Featured here is a Meccano model of just such a loader which can be built with a No. 5 Set plus the now obsolete Meccano Emebo Motor.

Construction is perfectly straightforward. Beginning with the loader mounting, two 12½ in. Strips 1 are bolted one to each side flange of a 5½ × 2½ in. Flanged Plate 2, the securing Bolts in each case also fixing a 5½ in. Strip 3 and a 3½ in. Strip 4 in place. An Emebo Motor is bolted to the top of the Flanged Plate, then the ends of Strips 1 are joined by two 2½ × ½ in. Double Angle Strips 5, the connection being made by ordinary Bolts in one case and by ⅜ in. Bolts in the other. Mounted free on the shanks of these ⅜ in. Bolts are two 1 in. Pulleys without boss 6. Strips 3 and 4 are brought together at the top, their upper end holes providing bearings for a 5 in. Rod, held in place by Spring Clips, on which a 2 in. Pulley 7 is fixed. The loader conveyor unit will later also be mounted on this Rod.

Production of the conveyor unit itself should present no problems. Two 23½ in. compound angle girders 8 are each built up from two 12½ in. Angle Girders overlapped three holes, the compound girders then being fixed together, in the centre by a 1½ × ½ in. Double Angle Strip 9, three holes from one end by two Angle Brackets joined by a 1½ in. Strip 10, and four holes from the opposite end by another two Angle Brackets joined by a 1½ in. Strip 11. Note that two packing Washers are mounted on each Bolt fixing Double Angle Strip 9 to the girders.

Journalled in the end holes of girders 8, near to Strip 10, is a 2 in. Rod held in place by two 1 in. fixed Pulleys 12. Two similar 1 in. Pulleys 13 are used to hold a 3½ in. Rod in place in the opposite end holes of the same girders, a 57-teeth Gear Wheel 14 also being mounted on this Rod. The Gear Wheel meshes with a ½ in. Pinion on a 4 in. Rod 15, held by Spring Clips in Girders 8, this Rod also carrying a 3 in. Pulley 16 at one end. Two 23½ in. compound strips 17 are then each built up from two 12½ in. Strips and are attached to compound girders 8 by a ½ in. Reversed Angle Bracket 18 and two Angle Brackets each extended by a Flashplate 19. A Flat Trunnion 20 is bolted to each compound strip.

For the actual conveyor belt, two identical lengths of strong cord a little over 4 ft. long are required, together with a number of 2½ in. Strips 21 (we used eight). The Strips are attached to the cords at regular intervals by pushing small loops of cord through the second holes of the Strips and then fixing a matchstick through the loops, as shown. The loops are then pulled tight. A little glue can be applied to hold the matchsticks in place. If available, short Meccano Rods can be used instead of matchsticks, although the matches are quite adequate. When the Strips have all been secured, the cords are passed round Pulleys 12 and 13, are pulled tight and the ends tied together to form an "endless" belt. The complete conveyor unit is then mounted, by means of Flat Trunnion 20, on the Rod carrying Pulley 7, this

The drive to the actual loading conveyor is taken to 3 in. Pulley 16 by a Driving Band and then transferred to the conveyor through a reduction gear system, as this picture clearly shows.

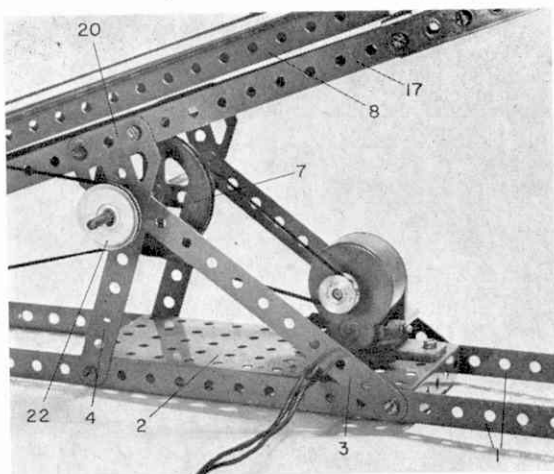

Pulley, incidentally, being connected by a 6 in. Driving Band to a ½ in. Pulley on the output shaft of the Emebo Motor. Fixed on one end of the Rod is a 1 in. Pulley 22, this, in turn, being connected to Pulley 16 by a 10 in. Driving Band to complete the model.

#### PARTS REQUIRED

6-1	1-23a
2-2	1-26
2-3	1-27a
8-5	6-35
2-6a	44-37a
4-8	38-37b
4-10	12-38
8-12	1-48
1-15	2-48a
1-15b	1-52
1-16	4-111c
1-17	2-125
1-19b	2-126a
1-20a	1-186a
5-22	1-186b
2-22a	1 Emebo Motor
2 lengths Cord	8 Matches

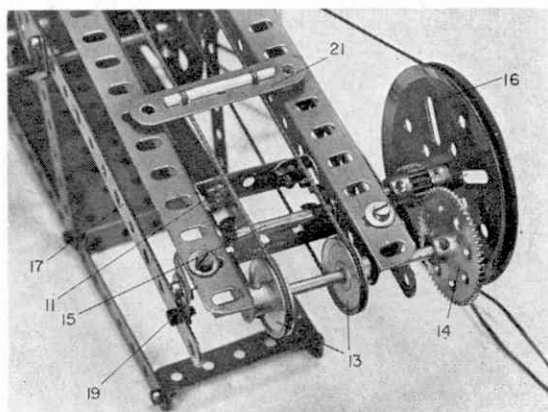

# ON TWO WHEELS

## Meccano Staff test Scooters, Mopeds, and Motorcycles

**I**T HAD BEEN some years since we had last ridden a Vespa, and we were all looking forward to the day when the new 125 ccs Vespa Primavera would arrive. When it eventually appeared it looked not very different from the earlier models. The familiar Vespa "blisters" were slimmed down slightly, but apart from that it seemed to have changed very little. It even sounded like all the previous machines: the characteristic engine whine and muffled clunk as the gears were changed showed that in mechanical design the same basic system was still being used and proving that the original design must have been sound and practical.



The large front mudguard prevents water from being thrown over the machine and rider in the wettest weather. Note the rather unusual suspension system.

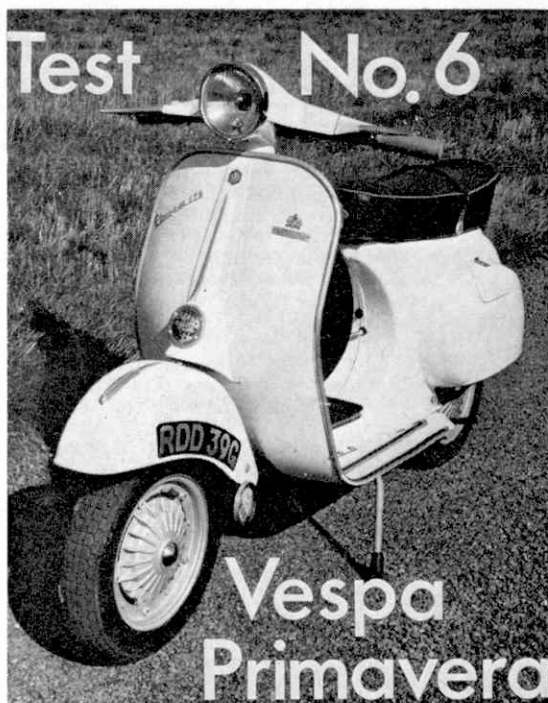

By no present day standards could the Vespa 125 be described as fast. But for the beginner, or someone unconcerned with high speeds, it makes a comfortable, quiet and cheap way of getting mobile.

Once astride the machine the first point that shows itself is the distance from the seat to the footboards, which are rather lower than most rival machines. This, we hasten to add isn't a bad point, in fact once used to it the driving position can't be faulted. The handlebars are well positioned a comfortable distance from the seat, and careful planning has obviously gone into the siting of the various controls.

The gearchange and clutch lever are operated by the left-hand, the former on our machine was slightly "sloppy", the result of either stretched or badly adjusted cables. The clutch is very smooth and easily operated, a must on this type of layout as the left-hand does more work than any other part of the body on a scooter. The right-hand operates the front brake, which is very smooth and powerful; medium to hard braking using the front brake caused the front of the machine to take a "dive", rather alarming at first, although, as we were to find out during our test, perfectly safe. A small control box on the inside edge of the handlebar on the right side contained the engine cut out, horn button, lighting switch, and dip switch, all of which were simple to operate.

The speedometer, housing a mileage recorder is recessed in the centre of the handlebars and although accurate we found it rather hard to read, especially at night when it was rather poorly illuminated. The lighting was excellent, at both front and rear of the machine; the headlamp particularly threw out a penetrating beam which was clearly cut when the dip switch was operated. Power for the lights is by magneto only, so the faster the revs the brighter the lights.

### The Engine

Power source for the Primavera is a two stroke of 125 ccs. By modern standards the power produced is modest giving the machine a top speed of 50 m.p.h. First, or at most second prod of the well positioned kickstart had the engine running sweetly and quietly. Choke was required only when cold which gave the engine a very fast idle and it had to be rapidly closed once the engine fired. The engine was remarkably vibration free at all speeds, and well silenced. The throttle was rather slow to respond to rapid opening or shutting down, possibly a case of poor adjustment on our model.



### The Gearbox

In common with most scooters these days the Vespa unit is a four speed one and smooth in operation, apart from an audible "clunk" as gears are selected. This noise does however give the rider an indication that he has in fact changed gear, and none of our test riders complained about it!

### The Bodywork

The bodyshell of the Primavera is all-steel and free from sharp edges or awkward corners. The steering column can be locked when the machine is parked, as can the luggage boot. The legshields are high and wide, offering the rider maximum protection against the weather. The dual seat has a "bag hook" at the front end, very useful for carrying a briefcase or satchel. Directly below the hook are the choke and fuel tap of the normal on/off/reserve pattern.

The engine unit is mounted slightly off centre to the right of the machine and a small removable panel in the offside blister gives access to the spark plug and flywheel. The opposite blister is a lockable luggage boot, quite large, although rather narrow. Tools are kept in a square removable plastic container under the dual seat. A handbook and a small set of tools are provided.



### Summary

The Primavera is a small nimble machine of medium performance, comfortable to ride and cheap to run. Top speed is in the region of 50 m.p.h. which is quite adequate for local riding. There is no ignition switch, and therefore no key; a point we were not too keen on. The steering column can be locked, but should you inadvertently leave the key at home there is no satisfactory means of immobilising the scooter.

The riding positions and general comfort are very good although pillion rider with short legs might have difficulty reaching the footboards which finish forward of the side blisters. Without exception our test riders liked the quiet, vibration free ride and thought at £168.19.6 it represented good value for money.

### Accessories

The range of "extras" for the Vespa range of scooters is very large and includes spare wheel carriers, luggage carriers, crash bars, windscreen, etc.



Slimmed down rear side panels get the new Primavera well away from its rather bulbous predecessors and certainly give it a more attractive appearance.

### FOR THE TECHNICALLY MINDED

Cubic capacity	121.17 cc
Compression ratio	7.2 : 1
Consumption (per gallon)	120 miles
Weight	160 lb.
Gear ratios, engine to rear wheel	1st 14.74 : 1
	2nd 9.80 : 1
	3rd 7.06 : 1
	4th 5.31 : 1

Tyres	Front	3.00 x 10 in.
	Rear	3.00 x 10 in.

Lubrication 2% oil through petrol

Common dimensions	Length 65 in.	Width 26 in.
	Wheelbase 46 in.	Weight 160 lb.

### Available colours

Hawthorn White — Sahara.

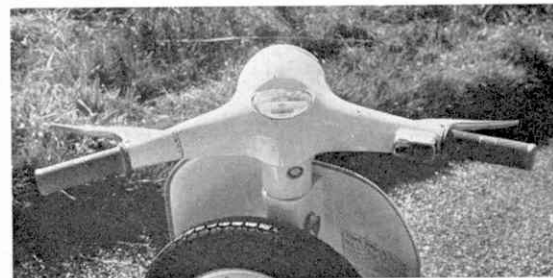

One of the nicer points about scooters is the absence of wiring and cables cluttering up the handlebars.



# DINKY TOY NEWS

## Chris Jelley previews six exciting new Dinky Toys!

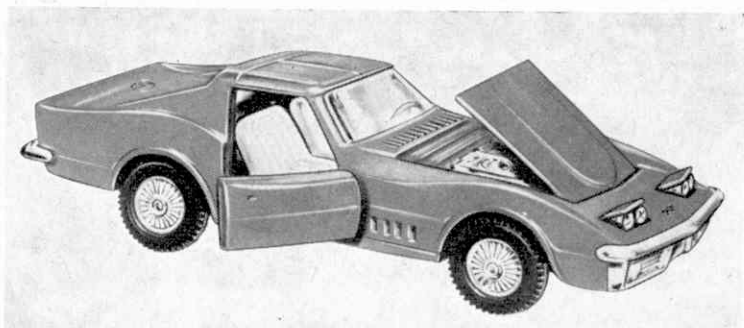

Heading photo shows Dinky Toy No. 221 Corvette Stingray—the first Dinky Toy to be fitted with swivelling twin headlights. Above: Dinky Toy No. 344 the long wheelbase Land Rover.

AS I WRITE this, the engineers at the Meccano factory in Liverpool are working flat-out on the design and production of no less than six new Dinky Toys! Yes, six, and all of them scheduled to go on sale in the very near future! By the time this magazine goes to press, in fact, some, if not all, of them will actually be in the shops, so you may have already bought them, or at least might have seen them on display, and, if so, you will have an advantage over me. I haven't seen them!

Below: Taken direct from the new Century 21 puppet series "Secret Service" No. 109 Model "T" Ford "Gabriel" complete with miniature "Father Unwin".

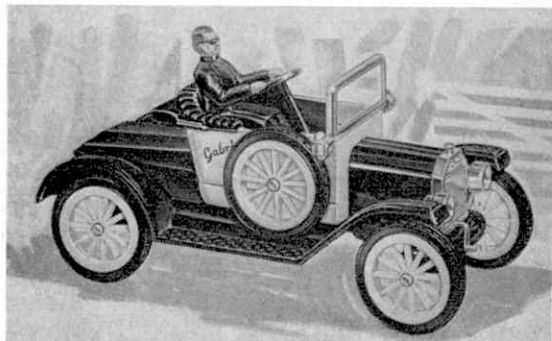

The reason for this is that, because of the Christmas holidays, this issue of the M.M. is being prepared even further in advance of publication date than usual and, as a result, none of the new models are available at the time of writing—November. Undaunted, however, I have managed to obtain artist's impressions of the new toys and I reproduce them here as a sort of "sneak preview" of the great things to come.

In the captions for the illustrations I have listed all the interesting features that I know from the plans are being fitted to the models, but I cannot of course give my usual detailed descriptions until I actually have finished samples of the models to study. These will come my way in due course, though, so I should be able to cover them fully in later magazines. In the



The new range of Dinky Toy aircraft caters for commercial passenger travel with the Boeing 737, No. 717. Finished in the livery of the German Airline Lufthansa, this unique model has a fully-retractable integrated lever-controlled undercarriage system which can easily be raised and lowered.

meantime, I trust that the accompanying illustrations and captions will be detailed enough to enable you to decide which models you want in your collection. I do know that all of them will be well up to Dinky's high standard and therefore will all make good additions to any collection.

Before signing off, I would like to offer my sincere good wishes to all readers for Christmas and the New Year. I realise, of course, that by the time you receive them, both Christmas and the New Year will have passed, but you will at least know that I did offer them in plenty of time!

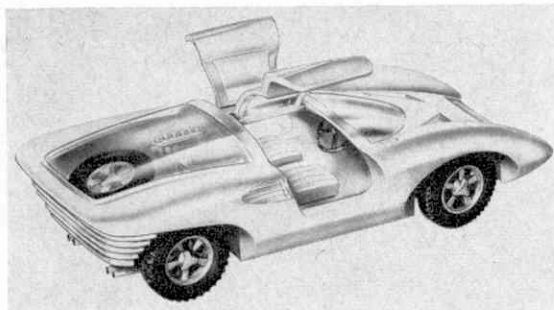

Above: The futuristic Ferrari P5 in Dinky form. The model No. 220 has a host of features such as Speedwheels, transparent rear engine cover, windows, seats, steering wheel and fully operational opening "gull-wing" doors.

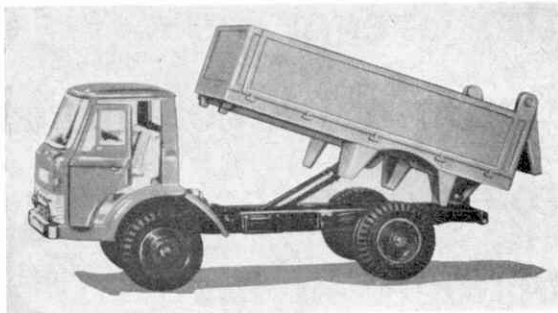

Above: In the commercial vehicle line, Dinky Toy No. 438 Ford D800 Tipper Truck. The cab is fitted with opening doors, windows and full interior fittings. The tipping body has an opening tailgate and simulated hydraulic ram.

### Stop Press !

News has just reached me that a Dinky Toy model of the Lotus Europa is being released under Sales No. 218 within one or two weeks of the time of writing which means that it will definitely be available when

you read this. It will have Speedwheels, an opening boot and opening doors, plus full interior fittings and jewelled headlamps. Advance reports claim it to be a beautiful model, so keep your eyes open for it! I will of course be reviewing it in detail later on.

*Continued from page 113*

### Radionic X30 Electronic Construction Kit

It is easy to see just by walking into any toy shop, that most of today's toys are designed to educate and to some extent they must manage to do this. But to be of any good the product must be two things: easy to understand and simple to use. Without a doubt the Radionic X30 Electronic Construction Kit is both of these.

The kit utilises a printed circuit base-board for all the experiments. The components included in the kit are mounted on plastic stands fitted with bolt-legs, which drop into the board and are held in place by nuts.

Certainly the main feature of the kit is versatility; a total of 33 experiments can be made using only the components included in the outfit. A fully illustrated instruction manual is supplied, which not only gives precise directions for all the experiments but also explains how they work and what use they have in industry.

The Radionic X30 constructional kit, though rather expensive at £7.19.6 is a really worthwhile and invaluable gift for the electronically minded teenager.

Radionic Products Ltd., are members of the E.S.L. Bristol Group, Broad Street, Bristol, BSI 2HF.

Above: The "MATCH BOX" Superfast Loop Set with the new Lamborghini Miura. Below: Radionics X30 Electronic Construction Kit.

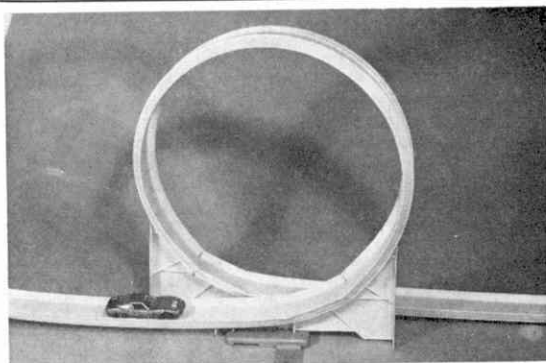

### "MATCHBOX" Superfast Loop Set

Certainly one of the simplest games on the market today is the "MATCHBOX" Superfast Race Set. It is quick and easy to set up and requires no power what-so-ever to run. The speed of the cars, and believe me they're really fast, relies entirely on gravity.

The set in front of me, the SF-2 Loop Set, is one of five including SF-1 Speed Set, SF-3 Curve and Space Leap Set, SF-4 Double Loop Race Set and SF-5 Double Track Race Set, prices ranging from 12/6d. to 45/-. The SF-2 Loop Set consists of one Superfast car, 12 feet of track one loop support, five track joiners and one clamp (used for connecting the track to a table or chair).

To play just join the track together, forming the loop about half-way. Fix the clamp to a suitable height, place the Superfast car on top of the clamp and then "Let her go!"

The illustration on this page shows the formation of the Loop and just going into the Loop is the latest Superfast car, the Lamborghini Miura. This really handsome model is finished in gold, with a well detailed interior, headlight and tail-light simulations and opening doors.

The producers of "MATCHBOX" are Lesney Products & Co. Ltd., Hackney Wick, London, E.9, and their products can be seen in all good toy shops everywhere.

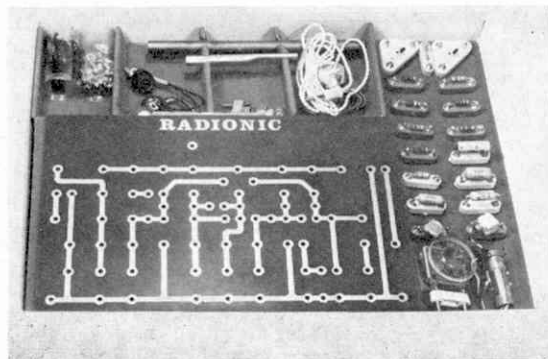

**Dr. Gregor  
Drummond continues  
to explain the theory  
of logic in his  
feature . . . .**

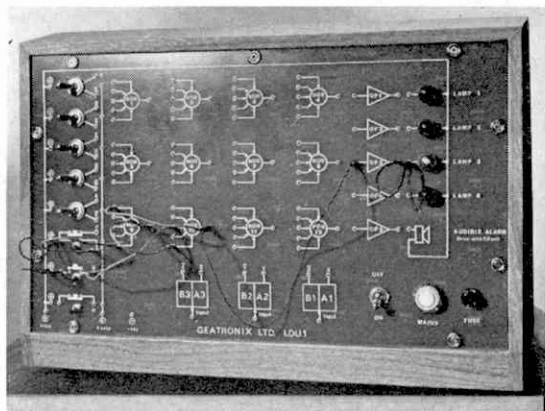

## THE A.B.C. OF COMPUTERS

**R**EMEMBER THAT positive and negative logic have nothing to do with positive and negative electricity. The names refer to whether the output is activated by something happening or by something not happening.

The function of a logic gate (that is, what the gate *does*) can be represented by a table which relates various states of input with the outputs they produce. For example, if we had a 2-input AND gate its functions could be represented as:

A	B	OUTPUT
on	on	on
on	off	off
off	on	off
off	off	off

showing that inputs A and B must both be *on* if we are to get an output. A 2-input OR gate has the following function-table:

A	B	OUTPUT
on	on	on
on	off	on
off	on	on
off	off	off

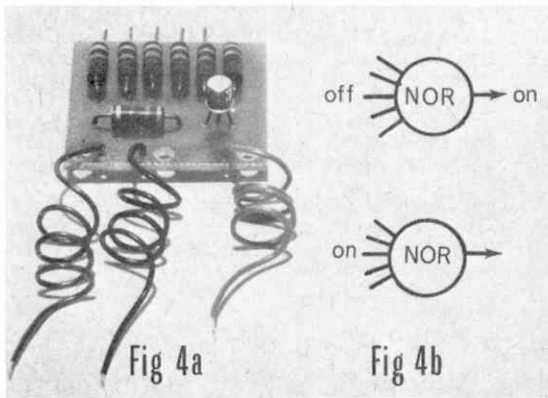

indicating that we shall obtain an output if either input A or input B is *on*. Similarly, the NOR gate that we have been talking about, used in negative logic, would have this function table:

A	B	OUTPUT
on	on	off
on	off	off
off	on	off
off	off	on

telling us that both inputs A and B must be off before we can get an output. Just to complete the picture, here is the table that goes with a NAND gate:

A	B	OUTPUT
on	on	off
on	off	on
off	on	on
off	off	on

Quite a few valuable logic systems can be made from NOR gates, such as the one illustrated in Figure 4a. There is no need to know what the various electronic components in the module do or to bother about its very simple battery power supply. All we need to know is in the block diagram of Figure 4b. This shows us

**Fig 4**

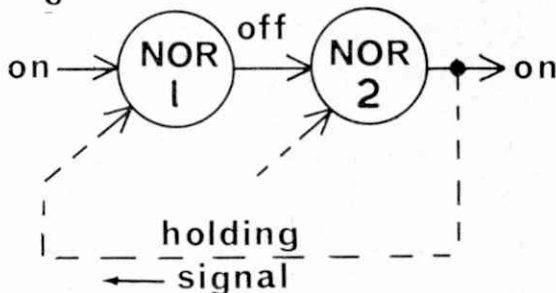



that we will only get an output if there is no signal going into any of the five inputs.

We can put it another way and say that if there is no input at A and B and C and D and E then there will be an output. As you can see from the function tables, this means that the unit can also act as a NAND gate, depending on how it is connected to other things.

A single one of these NOR units will carry out all the decisions required by our lazy gardener. Inputs A, B and C would be used as a NAND component and connected to sensors for light, temperature and pressure, respectively. The relays would be arranged to open when the sensors are activated.

Inputs D and E would function as the NOR component and would be connected to the clock switch and the water-contact sensor. The clock switch relay would remain closed until seven o'clock and the water-contact relay would close if water reached the sensor.

So, by using a single logic unit measuring only  $1\frac{1}{2} \times 1\frac{1}{2}$  in. and costing only 8/6d. all this thinking can be done for us electronically.

Should we wish to work in positive logic, that is, have an output whenever an input goes on, we simply connect two NOR units together. The output from one unit is connected to any input on the second unit, leaving the other inputs unused. This set-up is shown in Figure 4, ignoring the dotted lines for the moment.

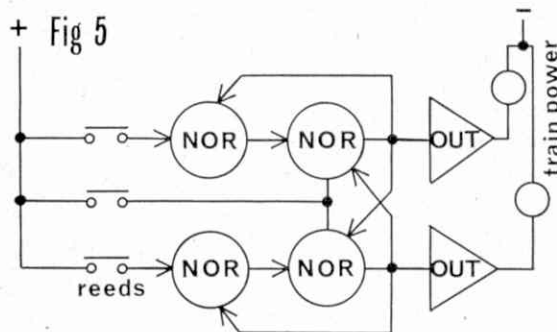

When an input is applied to NOR 1, its output stops, so there is then no input to NOR 2, whose output therefore comes on.

The dotted lines in Figure 4 show how a memory circuit can be made with Geatronix NOR units. Without the connections of the dotted lines, the output of NOR 2 will only stay on while the input to NOR 1 is being applied. But if we add the new connections then a *momentary* input to NOR 1 will cause the output from NOR 2 to come on, and part of this feeds back to NOR 1, so keeping up the output indefinitely.

If a momentary signal is now applied to the second input of NOR 2 then its output ceases, which means that the holding signal to NOR 1 also ceases, so the output stays off indefinitely. In this way, the circuit can 'remember' whether the last input was into NOR 1 or NOR 2.

Obviously, by adding more NOR units extremely complicated logical operations can be carried out. And yet with the available assembly rods and spacing cylinders a very compact outfit results, as seen in Figure 7.

The Geatronix logic system incorporates an OUTPUT unit which makes the weak output of a NOR unit strong enough to drive a sizeable relay or lamp. Figure 6 shows a neat arrangement of six NOR units

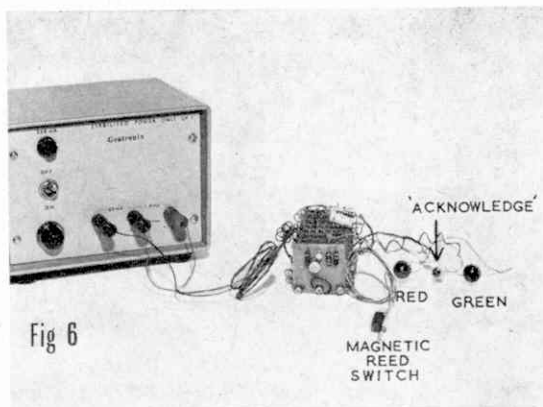

Fig 6

and two OUTPUT units connected to form an alarm annunciator.

At some central point in, say, a railway control office, a whole series of these annunciators will be connected to such things as points and signals on the rail system. While all is well the green light stays on. If at some distant place the wrong point closes, the magnetic reed switch will operate. This turns off the green lamp and makes the red one flash.

When the control engineer sees this he 'acknowledges' the alarm by pressing the button-switch. This makes the red light stay on all the time. A quick telephone call and the points are put right. This automatically switches off the red lamp and turns on the green one—and the engineer goes back to his pipe!

Thus in such wide fields as model railways, model car-racing, radio-control and working Meccano models, logic units can greatly add to the fun. Figure 5 gives you a circuit required to stop two trains reaching points or a crossover at the same time. The reed switches go on the tracks and the magnets go on the trains. See if you can work out how the train nearest the crossover cuts off the power to the other train and then switches it on again when the first train is well clear of the crossover.

Then imagine what apparently miraculous control you could demonstrate to your friends if you applied a little thought to incorporating logic into your models!

(Catalogues of logic units are available from: Geatronix Ltd., 28 Redstock Road, Southend-on-Sea, Essex.)

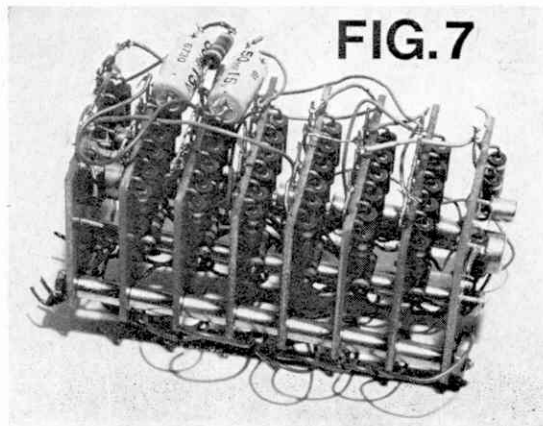

FIG.7



Below: V. Sokolok of the U.S.S.R. on the starting line of a Night Time Trial, which have become a popular part of the tour.



EACH YEAR in the last week in May and the first in June literally millions are enthralled, by the sheer daring of high speed on two wheels, when once again the "Milk Race" sets out on its annual tour of Britain. The Race has now become an established

Above: The start of the 1969 Race from Montague Place, Worthing. Although they know there is 14 days of strenuous cycling ahead of them, all the competitors with perhaps the exception of No. 36 on the left, look quite happy.

Below: Long hills are a common thing throughout the Race, and here we see the main bunch of riders in the 1969 Race on such a hill.



Right: The winner of the first stage of the 1969 Tour of Britain Milk Race from Worthing to Swindon, a distance of 102 miles, Kazimierz Yasinski from Poland, who clocked 4 hours 1 min 34 secs for the distance.

event in the International sporting calendar, attracting the best amateur cyclists in the world to compete in the 1,300 mile race. To those who have watched the race it conjures up a gay cavalcade of colour, in fact a carnival atmosphere.

This year's race will start in Blackpool with an Individual time trial on Sunday night the 24th May, but the race proper will start the following day. The race then moves on in stages to Carlisle, South Shields, Middlesborough, Bridlington, Kingston-upon-Hull, Skegness, Nottingham, Birmingham, Great Malvern; and then into Wales, to Portcawl, and on to Weston-Super-Mare, Weymouth, Southsea, and on to Brighton for the finish on Saturday, 6th June. Readers living in the Brighton area, will have a splendid opportunity for seeing the riders, for Brighton will stage the last three finishes. The cyclists will race in from Southsea, and the following day will see the climax of the race with an individual time trial in the morning, and a 70 mile circuit of the town in the afternoon. The circuit will be 10 miles by 7 laps.



Cycle racing is a strenuous, and dangerous sport. The "Milk Race" route through the varied country side of England and Wales is well suited to test the stamina, and skill of the riders, to their limits. The dangerous side was brought home on the first stage of the 1969 race when a young Czechoslovakian rider Zdenek Kramolis was killed thirty-five miles after the start, when he hit a lorry head-on as he descended the twisting road into Liss, Hampshire; during the course of the race riders will suffer many cuts and grazes.

International teams from the continent and from behind the Iron Curtain are expected to take part in this year's race, including teams from Russia, Poland, Switzerland, Western Germany, and the Netherlands. British interest will be represented in teams known as Great Britain, England, and the Provinces.

For the twelve teams of six riders competing, there are many hundreds of pounds worth of prizes to be won. These are divided up into the following sections:

Above: The Chief Commissaire up with the leading riders, in his distinctive white car. Right: The Great Britain team at the starting line at Worthing: Sid Barras, Peter Buckley, Doug Dailey, Dave Mitchell, Dave Palling and Dave Rollinson.



**The Team Classification Award.** This is made on the aggregate time of the first three members of the team on each stage. Time penalties are added for breaking race rules such as ignoring road traffic signs, and even for throwing litter.

**The Points Classification Award** is won by the rider obtaining the highest number of points throughout the race. Fifteen points for a stake win, and so on down to 15th rider who only gets one point. The points classification leader wears a pink jersey during the race.

**"The King of the Mountains" Contest.** Special hill climbs known as "Primes" are included on the stages and are graded according to the severity of the climb, points are awarded to the first riders up them. The "King of the Mountains" wears a white jersey with a black collar and sleeve edging.

**The General Classification Award.** This award goes to the rider with the lowest total time after all bonuses are deducted, and time penalties added. This rider is known as the race leader and wears the coveted "Yellow Jersey" of the race leader.

Although many prizes are won by individuals, in the "Milk Race", it is unlikely they can achieve this success without true team spirit from their colleagues. The huge task of organising the race, which takes from one year to the next lies on the shoulders of Race controller Bill Sqaunce, and Race Organiser Maurice Camberworth. It is Bill's job to do the actual physical





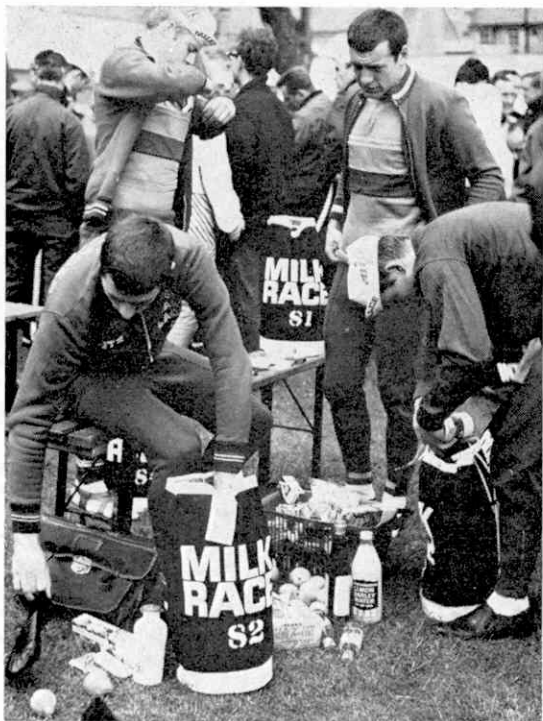

Above: Some of the riders making final preparation before the start at Worthing. Below: Dave Palling receives attention from the Great Britain team manager, before the start of a day's stage.



organising of the race, while Maurice looks after the race on the road.

Some of the equipment that is used in the race may be of interest and is as follows: 140 Racing Cycles, 400 spare cycle wheels, 1,000 safety Pins, and 1,000 racing caps; while the "Milk Race" consumes 20,000 Pintas, 6,000 oranges, 3,000 pears, 5,000 apples, and 2,000 bars of chocolate; all this helps to replace the lost energy of the racing cyclist.

The Tour of Britain cycle race has progressed a long way since it was started in 1951 and then organised by the "Daily Express", prize value in that race was only £850, and the race covered the 1,403 miles at 22.22 m.p.h. While in 1969 80 riders rode 1,436 miles at an average speed of 24.57 m.p.h. to win a total prize value of £5,200, and the prize value in 1970 will be even bigger.

For fourteen days the race will be on the road; in its wake will be a convoy of cars, vans, motor-cycles, carrying judges, time-keepers, marshalls, press, and publicity men, all the trimmings which go to make this, not only the top amateur cycle race that it is, but a colourful spectacular event. 1970 promises to be no exception.

Above: Some of the 14 motor-cycle Marshalls wait for the start of a day's stage. Below: A final check on tyre pressures.



## GREAT ENGINEERS No. 25

# JAMES NASMYTH

## (1800-1890)

by A. W. Neal

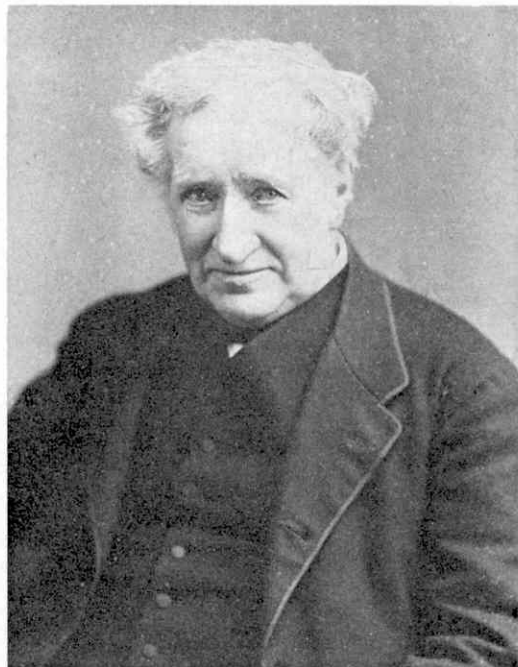

A SCOTSMAN, born in Edinburgh, James Nasmyth was one of ten children of Alexander Nasmyth, an artist. As a child he showed an aptitude for handicrafts, and so he became known as the 'little Jack-of-all-trades'. At the age of nine he began attending Edinburgh High School, leaving three years later to work in his father's workshop and studio. Then he attended the School of Art until he reached the age of 18 years. We find him making small steam beam engines, some of which he sold to pay for courses in Chemistry and Mathematics at the University. Much of his spare time was spent in visits to various works and similar pursuits. He converted his bedroom into a foundry to melt brass and, of course, used his father's workshop. It is interesting to note that he made a steam road vehicle about this time, but he appears to have soon lost interest in the subject.

Then came the turning point in his life. In 1829 he was fortunate enough to obtain employment at the famous works of Henry Maudslay at Lambeth. In his first year there he constructed a special form of milling machine, assisted in the reconditioning of an engraving machine for the Royal Mint, designed a flexible-shaft drilling machine, and made a speculum for his master's reflecting telescope. Another project that greatly added to his experience was his drawings for a 200 p.h. steam engine for the Lambeth Waterworks. He started an 'ideas book' in which he noted down schemes that occurred to him from time to time.

1831 saw the end of his employment at Lambeth. He went to Leigh and set up a small workshop, and with his father's little lathe he built a much larger one, a planing machine and other machine tools. He took on a millwright, a labourer and an apprentice. His total capital amounting to £63. He at first made a moderate livelihood by accepting a large variety of jobbing work, then, as business increased, he rented a cellar as a smithy. He undertook all work on a cash basis and his bank manager advised him to 'As soon as you can, lay by a little capital of your own and baste it with its own gravy'. His next step was to rent a 6-acre site near Patricroft and to establish a temporary workshop there. He built key slotting, shaft centring and shaping machines. In 1838 he invented a safety ladle for pouring molten metal. He took Holbrook Gaskell in as a partner, an association that lasted until the latter retired 16 years later. The temporary workshop disappeared and the large Bridge-water Foundry built. Out of these works came locomotives for the Great Western Railway.

In his autobiography Nasmyth tells of an enquiry he received for a 30 in. diameter paddle wheel shaft for a new steam ship. It appears that nobody had the facilities to undertake such a task. Within 30 minutes he schemed out a suitable hammer. It was to have a head attached to a piston rod, the piston acting in a

steam cylinder. The moving parts were to be raised by steam in the cylinder and allowed to fall onto the work resting on an anvil. There was to be suitable control equipment. The craft was never made but the hammer was, and Nasmyth's name will always be connected with this invention. The first hammer he made had a 30 cwt. head and a lift of 4 feet, and it was installed at Patricroft. The first order received for such a hammer was one erected in the Admiralty's Devonport Dockyard. Nasmyth then developed a steam pile driver and one was used in the construction of new docks at Keyham. Many orders were received for both hammers and pile drivers. This uneasy man (in the kindly sense) went on with numerous ideas. He invented a ventilating fan for coal mines, a safety valve for steam boilers, an hydraulic punch, baling presses, a calico printing machine and a variety of other special machines. His export drive included machine tools for Havana and equipment for rope making at Nicolaiev on the Black Sea.

His interest in astronomy was always great, possibly going back to his days at Lambeth. He had made himself a 10 in. reflecting telescope in 1840; later he made another, a 20 in. instrument this time, and later on still he added a turntable to it. In 1854 he devised a reversible plate rolling mill which had advantages over other mills of the day. It was first used in the Crewe Works of the L.N.W. Railway. About this time he took out a patent for processing steel.

But he was beginning to feel the strain of long years of work and endeavour, and upon reaching the age of 48 he retired, settling at Penshurst, Kent, near the ancestral home of the Sidney family. He continued with his hobbies until he died in 1890.

One forms the opinion that James Nasmyth was a kindly and unpretentious man. He was certainly a man of vigour and courage, and any young man with aspirations to rise in the engineering profession could not do better than follow in his footsteps.

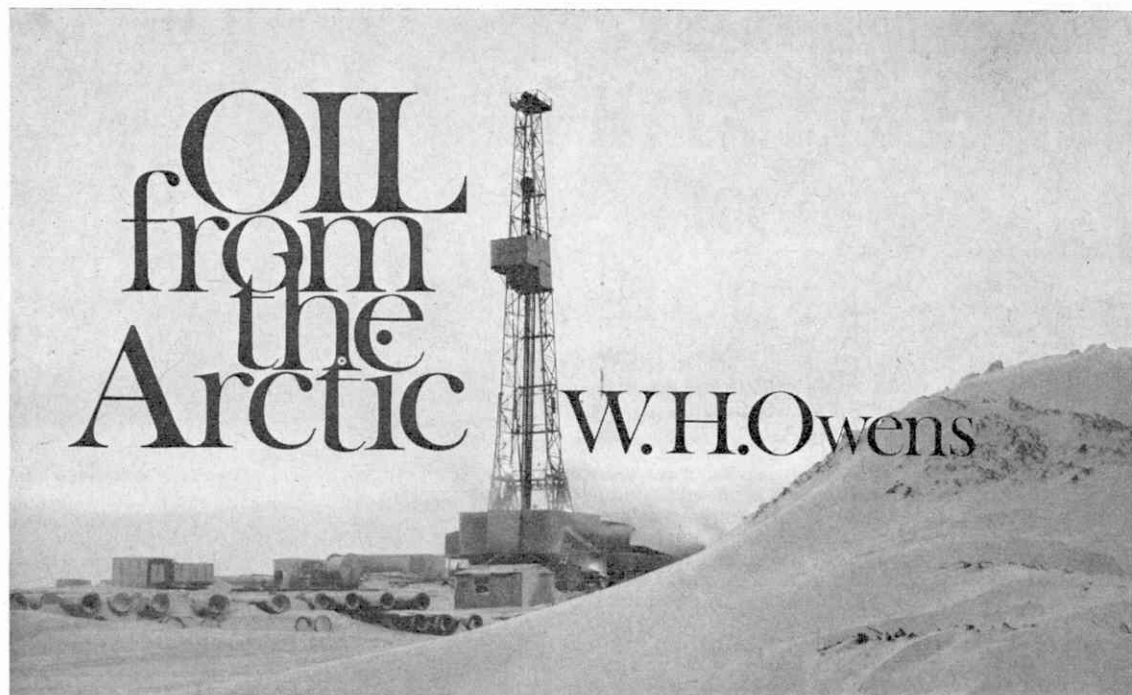

**T**O SATISFY the growing thirst for oil in every civilised country, the big international petroleum companies are spending vast sums of money on exploration and trial drilling in many corners of the world. The search for new sources of this vital mineral goes on continuously in all the five continents, as well as in the shallow seas round about them.

One of the most promising oil strikes of recent years has been made inside the Arctic Circle—on the barren North Slope of Alaska—where British and U.S. drilling teams are working in extreme low temperatures among the most difficult conditions to be experienced anywhere. British Petroleum have three rigs in operation in the vicinity of Prudhoe Bay where their first significant find was made early in 1969.

These Alaska oil deposits are among the largest yet discovered in North America. For the North Slope oilfield is estimated to contain between 5,000 million and 10,000 million barrels of crude oil, hidden

thousands of feet below the snows and permafrost.

But this is only a small part of the fabulous oil riches known to exist throughout the Arctic Circle, in Canadian and Russian as well as U.S. territory. Trial drilling began recently on Melville Island, one of Canada's large group of Arctic Islands, where—following the first successful Alaska strikes in 1968—international oil interests have been staking claims on ground within hundreds of miles of the North Pole.

There is reason for optimism that oil accumulations as rich as those in North Alaska could be found in the Canadian Arctic. For the bitumen-bearing sands exposed on Melville Island are of similar type and geological age to those around Prudhoe Bay, and it is highly probable that a belt of oil reservoirs occurs between the U.S. and Canadian deposits.

Winter temperatures on Alaska's North Slope normally range from 20 to 50 degrees below zero. But minus 60 or 70 degrees are by no means uncommon there. And when the bitter polar winds sweep across the barrens, the temperature has been known to fall as low as 100 below.

Under such conditions, men have to be tough to survive outdoors. At times when the winter cold is most intense, with fierce blizzards raging, no work is



Above: this strange creature here is only a worker wearing a woollen mask to protect his face against the bitter North Alaska wind. Right: a Hercules aircraft unloads stores and provisions for the Put River 1 Camp.





Right: the 35-40 m.p.h. winds make outside work impossible, when the temperature is down to 100 degrees below zero. Bottom left: a bulldozer clearing snow drifts in a blizzard. Bottom right: Put River No. 1 Camp Site.

possible in the open. But men who have to go out wear woollen face masks as well as special clothing to protect the rest of their bodies. All camp buildings have thick insulated walls and floors, and even the drilling rigs and machinery have to be protected against the weather. High-pressure steam hoses are available to unfreeze equipment, valves and so on.

From about the middle of November until the beginning of February the sun is never seen in these Arctic regions, while for about two months every year—through December and January—there is practically no light at all. Artificial lighting burns all day long as well as through the night at the rigs and outdoor working sites, and the big freighter planes touch down and take off with their lights blazing.

Transport has naturally been a big and very costly problem in such a remote area of the world, where permanent roads do not exist at all and the coastline is locked by ice for the greater part of the year. Most of the time, therefore, the North Slope operations depend on a continuous, round-the-clock airlift. The huge Hercules air transports use a forward base at Fairbanks, in mid-Alaska, the one-time gold rush town which has recently become the world's northernmost oil city.

Everything from drilling rigs to living quarters, and daily supplies of fresh food for the oilmen, is carried in by air. For example, British Petroleum's airlift from Fairbanks to its drilling sites between December 1968 and July 1969 delivered some 19,600 tons of dry cargo by Hercules planes. This involved a total of 1,067 separate flights with an average payload of 41,145 lb. In the same seven months period nearly a million and a half gallons of fuel oil were delivered on a further 224 flights by Constellation airtankers.

During the winter months, supplies and equipment are also brought in along Alaska's "ice road", bulldozed from Fairbanks north to Prudhoe Bay—a distance of some 400 miles. This road, however, becomes unusable in the summer, when the upper layer of permafrost degenerates into the swampy condition known in the Far North as muskeg. Then, when the permafrost hardens, the road has to be dug out again. But the cost and effort of it is worth while to have a surface supply route open for several months of each year.

For just about six weeks of the Arctic summer, barges join the planes in moving freight to the North Slope drilling areas. The ice pack blocking the sea



routes all the winter moves out from the shallow channel near the shore during the warmer weeks, leaving a free passage for barges and tugs. But the use of the sea route has become an intricate process of careful planning and timing, taking into account the winds that might move the ice back into the cleared channel, bad weather and other unforeseen events.

In the summer of 1968, BP sailed their first drilling rig and its equipment through the Bering Straits to their drilling site at Prudhoe Bay. This sea route was pioneered some years ago to supply the chain of radar stations, known as the Dew Line, ranged along the northern coasts of the United States and Canada.

During the 1969 navigation season in Arctic waters much greater quantities of supplies were taken by sea transport before the ice closed in again. Another supply route used in summer is down the great Mackenzie River of north-west Canada, by barge from the northern rail terminal on Great Slave Lake, and thence along



The drilling floor at Put River 1 Camp. Here several Eskimos are employed in skilled jobs—this picture shows an Eskimo welder at work.

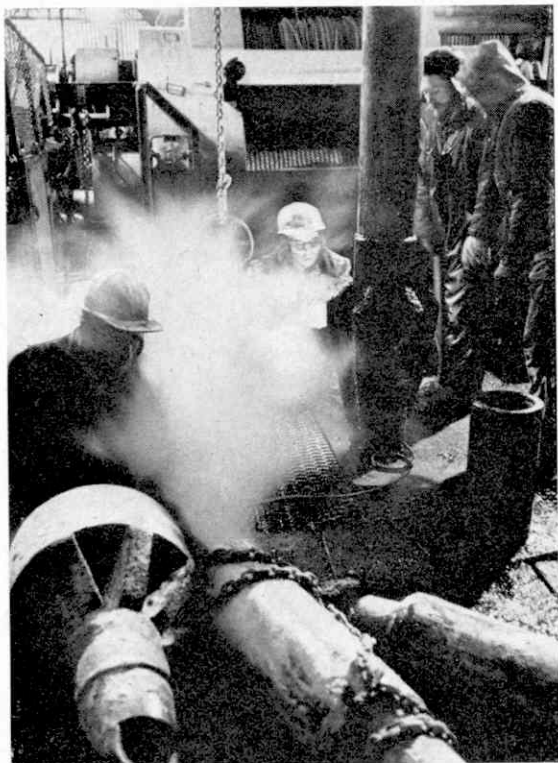

the Arctic coast. But this route too is open only for about six weeks.

Crude oil from Northern Alaska could be flowing to an ice-free port in the south of the territory by the end of 1972, when the big 800-mile-long pipeline is completed. This—the largest diameter pipe in the world—will connect with a new oil terminal to be built on the Gulf of Alaska, from where the oil can be readily distributed to markets throughout the western United States.

Meanwhile the possibilities of moving Arctic oil away by sea are being thoroughly investigated. In the last two summers experiments and trials have been carried out with ice-strengthened supertankers which, it is hoped, might be able to force their way through the ice of the historic North-West Passage, between the Arctic and Atlantic Oceans, all the year round. If it is possible to ship oil in specially built tankers through the ice-infested seas, then Arctic oil will eventually reach refineries here in Great Britain.

In 1968 the Canadians made the first trials in Arctic waters with the Alexbow ice-plough, a new and highly efficient icebreaking technique which may solve the problem of transporting oil from the Arctic islands, where (unlike Northern Alaska) no pipeline connection is possible. Mounted on a barge and pushed by a tug, the ice-plough successfully penetrated ice five and six feet thick, and also sliced through a pressure ridge some 20 feet high without any difficulty.

The Americans have transformed one of their most powerful supertankers—the 115,000 ton 'Manhattan'—into the world's largest icebreaker. This was done by replacing the original 65 foot forward bow by a new 125 foot icebreaking bow, and strengthening the rest of the ship with strips of reinforced steel to withstand the impact of ice. On the outcome of the full trials with the "Manhattan" and the Alexbow icebreaking device will depend how far supertankers may be able to break the great white barrier of the Arctic and distribute its black treasure across the seas.

# AMONG THE MODEL BUILDERS

Readers' Meccano  
ideas described by  
Spanner

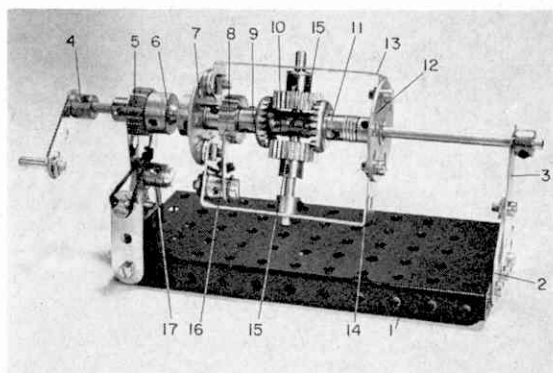

- ★ Constant-Direction Drive
- ★ Variable-Speed Unit
- ★ Free-Wheel Mechanism

**B**EFORE DOING anything else this month, I would like to express my sincere hope that all M.M. readers, especially Meccano modellers had a very merry Christmas and a splendid New Year. I suspect, though, that I might be just a little too late with my wishes for some people, who, as they read this, are already trying their best to forget all about the "festive season"—helped along by an upset stomach from too much of the "festive spirit"! I might well be doing the same, but it's difficult to be too explicit at this stage: as I write this Christmas is still six weeks in the future!

### Constant-Direction Drive

Upset stomach or not, however, I still have some interesting mechanisms to present, the first of these being a Constant-direction Drive Unit designed by Mr. M. C. Tomkinson of Sandbach, Cheshire. No matter in which direction the input shaft of the Unit is turned, the output shaft always revolves in one chosen direction only.

A glance at the accompanying illustration will show that the mechanism is built-up around a differential carried in a simple mounting. Mr. Tomkinson stresses, however, that the unit, as illustrated, was produced for demonstration purposes only and that individual readers may need to adapt it to meet their own requirements. As it stands, the mounting is produced from a  $5\frac{1}{2} \times 2\frac{1}{2}$  in. Flanged Plate 1, to each end flange of which is bolted a Flat Trunnion 2 extended by a  $2\frac{1}{2}$  in. Strip 3.

As regards the actual mechanism, the input shaft is supplied by a  $3\frac{1}{2}$  in. Rod, mounted in one Strip 3 and fitted with, in order, a Crank 4, a Collar, two Washers, a Ratchet Wheel 5, a Socket Coupling 6, an 8-hole Bush Wheel 7, a second Ratchet Wheel 8 and a  $\frac{3}{4}$  in. Contrate Wheel 9, the Rod then being inserted, free, part-way into the longitudinal bore of a Coupling 10. Note that Ratchet Wheel 5 and Bush Wheel 7 are carried in opposite ends of Socket Coupling 6, and that all three of these parts are free on the Rod. The remaining parts are fixed, the Collar holding the Rod in position.

Inserted, free, part way into the other end of Coupling 10 is the output shaft, supplied by another  $3\frac{1}{2}$  in. Rod mounted in remaining Strip 3. Mounted on this Rod are a fixed  $\frac{3}{4}$  in. Contrate Wheel 11, followed by a number of packing Washers and a loose 8-hole Bush Wheel 12, this Bush Wheel being attached to Bush Wheel 7 by one  $2\frac{1}{2} \times \frac{1}{2}$  in. Double Angle Strip 13 and one  $2\frac{1}{2} \times 1$  in. Double Angle Strip 14, using packing Washers where necessary to obtain correct hole alignment with Coupling 10. Contrate Wheels 11 and 9 mesh with two  $\frac{3}{4}$  in. Pinions 15 fixed, one in a 1 in. Rod and the other on a  $1\frac{1}{2}$  in. Rod, both Rods being mounted in the centre transverse bores of Coupling 10 and in respective Double Angle Strip 13 or 14. A Collar holds the  $1\frac{1}{2}$  in. Rod in place.

Mounted on the Pivot Bolt fixed to one lug of Double Angle Strip 14 is a Pawl 16, the point of the Pawl being held in contact with Ratchet Wheel 8 by a  $2\frac{1}{2}$  in. Driving Band. In contact with Ratchet Wheel 5 is a second Pawl 17 mounted on another Pivot Bolt fixed to nearby Flat Trunnion 2. This Pawl is also held in contact with the Ratchet by a  $2\frac{1}{2}$  in. Driving Band secured to a  $1\frac{1}{2}$  in. Strip bolted to the side flange of Plate 1. Finally, a Threaded Pin is fixed to the arm of Crank 4 to serve as a handle.

**Left:** Full credit for this Constant-Direction Drive Unit goes to Mr. M. C. Tomkinson of Sandbach, Cheshire. The output shaft always turns in one direction no matter which way the input shaft is turned.

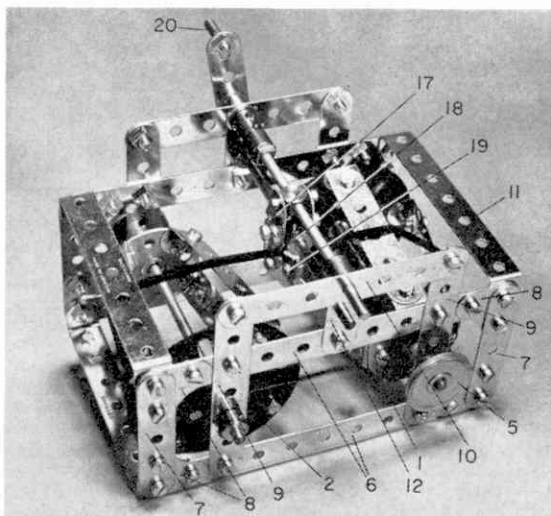

**Above:** It may look unusual, but this Speed Variation Unit is amazingly effective in operation. It was designed by Mr. N. Muallern of Tel-Aviv, Israel. **Below:** Many of our newer readers will not have come across a useful Free-Wheel Mechanism before now. This example was suggested by Mr. M. Miller of Ilford, Essex.

In operation, when the input shaft is turned in a clockwise direction, the whole mechanism, including the output shaft, revolves with it as a single item. If the input shaft is turned in an anti-clockwise direction, however, the action of Ratchet Wheel 5 brings the differential into play which results in the output shaft continuing to turn in a clockwise direction.

As a matter of interest, in submitting his idea, Mr. Tomkinson said it, "... can be used for winding something up where space does not permit a full turn to be made and it could also be used to improve a mechanism such as a ratchet spanner. Perhaps readers of *Meccano Magazine* could suggest better uses for it. If so, I would be interested to hear about them." So would I, so, if anybody has any ideas, please send them along to us.

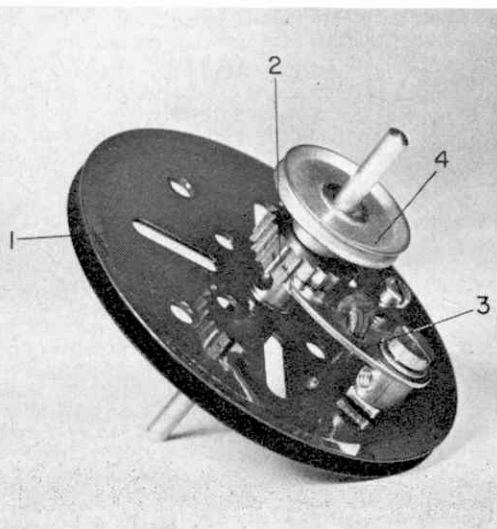



## PARTS REQUIRED

2-5	2-25	1-48a	1-115
1-6a	2-29	1-52	2-126a
2-16	20-37a	3-59	2-147
1-18a	12-37b	1-62	2-148
1-18b	10-38	1-63	1-171
2-24	1-46	2-111c	2-186

## Variable-Speed Unit

Also featured in the accompanying illustrations is a very simple, yet amazingly clever Speed Variation Unit, details of which were sent to me by its designer, Mr. N. Muallern of Tel-Aviv, Israel. Working on the opposed cones principle, the Unit will enable the speed of a drive system to be changed at will—and not changed through a set of fixed gear ratios, either, but rather varied gradually through its entire step-up or step-down range of ratios. The principles followed are really quite straightforward: two similar cones, one

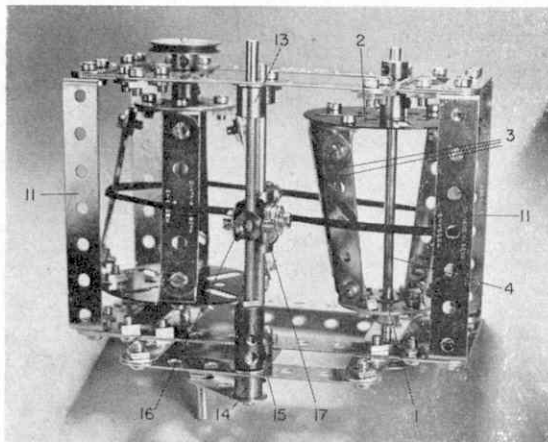

A top view of the Speed-Variation Unit showing the layout of the cones.

driven, are mounted parallel to each other, but pointing in opposite directions, and are connected together by an endless belt. As the cones revolve, the ratio between the two depends on the positions of the belt on the cones, therefore the ratios can be varied by simply altering the positions of the belt on the cones.

In Mr. Muallern's mechanism, each of the two cones are built up from one 8-hole Bush Wheel 1 and one Face Plate 2 connected together by four  $2\frac{1}{2}$  in. Strips 3 attached by Angle Brackets, the lugs of which are bent slightly to the correct angle. When finished, the cones are each mounted on a  $4\frac{1}{2}$  in. Rod 4 held by a 1 in. Pulley 5 and a Collar in a suitable framework. The framework illustrated consists of two similar sides each built up from two  $5\frac{1}{2}$  in. Strips 6 connected together at the ends by two  $2\frac{1}{2}$  in. Strips 7, with 1 in. Corner Brackets 8 being used to ensure rigidity. Two  $3\frac{1}{2}$  in. Strips 9 are also bolted between Strips 6, the upper ends of these being joined by another  $3\frac{1}{2}$  in. Strip 10, then the two sides are connected together at the corners by four  $3\frac{1}{2} \times \frac{1}{2}$  in. Double Angle Strips 11.

Bolted to the centre of upper Strip 6 at each side is a  $1\frac{1}{2}$  in. Strip 12, this being secured to relevant Strip 10 by either a Rod Socket 13, or a Crank 14 and Threaded Coupling 15 on a 1 in. Rod, as the case may be. Fixed in the threaded portion of the Coupling, but free to revolve in the Rod Socket, is a 3 in. Screwed Rod, carrying a Universal Coupling "spider" 16, the Rod being screwed through two opposite tapped bores of the spider. Tightly secured to the spider through its remaining tapped bores are two Fishplates 17, between the other ends of which a Coupling 18 is fixed, this Coupling being free to slide on a 4 in. Rod held by Collars in the centre holes of Strips 12. Note that the Fishplate securing Bolts must not foul either the Screwed Rod or the 4 in. Rod, therefore packing Washers should be used where necessary. Two  $\frac{1}{2}$  in. Bolts, each carrying a loose Collar 19, are locked by Nuts in the lower end bores of Coupling 18, the Collars acting as guides for a 10 in. Driving Band passed round both cones.

Finally, a Threaded Pin 20 is fixed to the arm of Crank 14 to provide a handle by means of which the Screwed Rod can be turned. As the Screwed Rod revolves, the spider assembly moves along it and the guides provided by Collars 19 alter the position of the Driving Band. Drive, of course, can be taken to either of Pulleys 5. It works extremely well.

## PARTS REQUIRED

4-2	1-15b	3-38	2-109
6-3	1-18b	4-48b	2-111a
12-5	2-22	6-59	1-115
2-6a	2-24	1-62	8-133a
2-10	2-35	1-63	1-140y
16-12	56-37a	1-63c	1-173a
2-15a	56-37b	1-80c	1-186b

## Free-Wheel Mechanism

I finish this month with a simple Free-Wheel Mechanism sent in by Mr. M. Miller of Ilford, Essex. Actually, regular readers will know that we have featured almost identical mechanisms to this in the past, but as we have not done so for some time, I am sure that there are many newer readers who will not have seen them.

Mr. Miller's particular example consists of a 3 in. Pulley 1, loose on a 3 in. Rod, but held in place by a Collar and a Ratchet Wheel 2. In contact with the Ratchet is a Pawl 3 on a Pivot Bolt held by Nuts in one of the outside circular holes in the Pulley, the Pawl being held against the Ratchet by a  $2\frac{1}{2}$  in. Driving Band slipped over a  $\frac{3}{8}$  in. Bolt fixed in one of the elongated holes of the Pulley. The drive is taken to a 1 in. Pulley 4, also secured on the Rod. It's simple, but effective!

## PARTS REQUIRED

1-16b	1-59
1-19a	1-111a
1-22	1-147
2-37a	1-148
1-38	1-186



**HAWKER SIDDELEY** have long been associated with anti-submarine aircraft and their Manchester factory, in particular, have been connected with maritime reconnaissance aircraft for over thirty years. Starting with coastal patrol Anson aircraft before World War II and continuing with the Lancaster specially adapted for coastal duties, Hawker Siddeley experience extends through the Shackleton to the present day.

In the light of this experience and in view of the R.A.F.'s modern requirement to combat the very latest nuclear submarines, Hawker Siddeley Aviation have developed the Nimrod—the world's most advanced maritime reconnaissance/strike aircraft—for service with the R.A.F.

From the go-ahead being given on the Nimrod programme in June 1965, design work and construction of the first two prototype aircraft was carried out for a first flight date of May 23rd, 1967. Since then, Nimrod aircraft have amassed a total of 1,200 flying hours, and a total of six machines have flown in a variety of trials in the hands of R.A.F. crews. In service, the Nimrod will replace the Shackleton MR2 and work alongside the Shackleton MR3 as the most formidable anti-submarine warfare aircraft available, with a high cruise speed of over 500 m.p.h. This high cruising speed does not however prevent it from loitering over a search area using only two of its four Rolls Royce Spey turbo-fan engines, but it does mean that the aircraft has the capability to cut down the unproductive time in getting from a shore base to the operational area. Together with its automated system, the Nimrod can achieve almost double the work of the long-service Shackleton, which it is replacing.

Nimrod has radar that can detect surface ships and even submarine periscopes or snorkels, and its other electronic equipment can locate sources of radar transmission. Should this not be enough, a sonar buoy can be dropped to locate under-water targets, and Nimrod is even equipped with a device to "sniff" the exhaust fumes from diesel engines. Finally, this revolutionary aircraft has a magnetic anomaly detector in the tail boom to indicate submerged vessels by their disturbance of the earth's magnetic field.

Normally, the Nimrod will carry a crew of eleven, who have all the comforts of sound insulation, pressurised air-conditioned cabins, well-designed lighting and a combined galley and dining area behind the tactical control room. In addition to its reconnais-

# TRANSPORT TOPICS by Mike Rickett

sance and anti-submarine roles, the Nimrod can carry out day and night photography and it is also capable of being armed with conventional bombs or air-to-air missiles. As an alternative, the aircraft can carry up to 45 troops, and extra fuel for long range ferry work can be carried in the bomb bay.

An air race to commemorate the 50th anniversary of the first England-Australia flight by Sir Ross and Sir Keith Smith has been organised under the sponsorship of BP, by the Royal Aero Club of the United Kingdom and the Royal Federation of Aero Clubs of Australia. Route surveys were completed at the end of September and both landing and fuelling arrangements completed for all classes of competitors—Piston-engined, propeller-turbine, pure jet, and helicopter. Pilots were able to plan their own routes providing that they include check points at Athens, Karachi, Calcutta, Singapore, Darwin, and Adalaide. All competitors are due to arrive on the 2nd January, the publication date of this issue of "M.M."

News also reached us of the completion of two new berths for super tankers in Angle Bay in South Wales and Finnart on the west coast of Scotland. Both are now in operation and several 200,000 ton tankers have unloaded at these new modern berths. Angle Bay can receive tankers of up to 250,000 deadweight tons, while at Finnart ships of up to 500,000 deadweight tons will be accommodated in the future. From both these terminals, crude oil is pumped through pipelines to BP's refineries in Wales and Scotland.

Another fascinating item of news that reached us concerns the "Bleep" radios that are now in experimental use at Paddington Station to help speed the flow of information and to help reduce the risk of delays. Based on pocket transmitters/receivers weighing only 5½ ounces, the equipment has been developed from that used for staff locating in hospitals. Paddington is the first station to go "on the air" and is hoped that the equipment will help key personal scattered throughout the 13-acre station to take decisions quickly and to ensure that full information can be passed on promptly to other staff and passengers.



# Niagara Falls are falling down

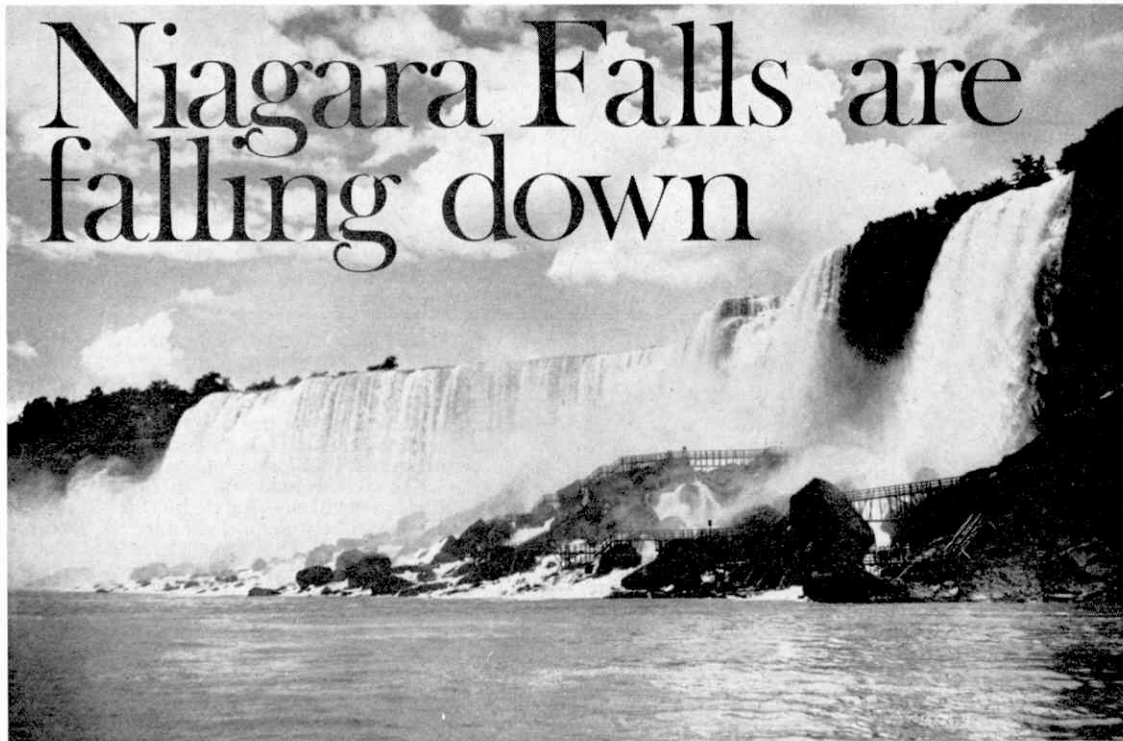

by Arthur Nettleton

LIKE THE old grey mare, the world's best-known natural cascade ain't what it used to be. Niagara Falls, in fact, are literally falling down, much to the dismay of tourists and the authorities responsible for maintaining this famous wonder. Its mighty roar has dwindled, partly as a result of diversions of the Niagara River to run generating plants further upstream, but also because erosion is eating away the cliff face at an alarming rate.

This stupendous geological feature on the border of the U.S.A. and Canada measures 4,000 ft. along its crest, but is separated into two cascades by Goat Island. The Horseshoe Falls on the Canadian side

are 155 ft. high and the American Falls 165 ft. Any appreciable reduction of the flow (normally 100,000 cubic feet per second!) not only affects the roar but also denies sightseers their opportunity to see another spectacle—the 50 ft. waves shooting up from the abyss below.

Engineers have been examining the face of the Falls to find and measure cracks and other faults liable to damage the escarpment permanently. Canadian firms dependent on tourist traffic are also concerned, and are pressing for action to restore the flow. But the fame of these waterfalls does not arise from their scenic importance alone. They have been accepted as a challenge by rash individuals anxious to earn personal distinction and a fortune by going over the brink in a barrel or other container, and hoping to escape drowning in the whirlpool below.

The first recorded stunt was carried out in 1829 by a Rhode Island cotton spinner, Sam Patch, but his feat was not widely accepted as a conquest of the Falls because he jumped from a ledge 100 ft. above the water between the American and Canadian Falls, and did not plunge over the brink. Nevertheless his achievement sparked off a long series of efforts by swimmers, tightrope walkers, and mountebanks eager to put themselves in the public limelight by wagering their lives against the main cascade.

Charles Blondin, the French-born tightrope exhibitionist, performed acrobatics on a wire stretched across the Falls in 1859 and 1860. For two summer seasons his performances attracted thousands of spectators. The climax was a crossing made with his

Above: The awe-inspiring Niagara Falls. At night they are illuminated by powerful floodlights using electricity generated by the falling water.

Left: Small steamers brave the turbulent waters to give tourists a close-up view of the Falls.





business manager on his back. It is said that when the aerial trip was over, his "passenger's" dark hair had become white! An invitation to carry the Prince of Wales (later King Edward VII) across was turned down, but Blondin did receive a purse containing £150 from the Prince as a token of admiration for the acrobat's daring.

Many attempts have been made to swim the roaring rapids and dangerous whirlpool at the foot of the Falls, and some odd devices have been constructed by dare-devils eager to get across by plunging over the cascade itself. It has claimed several victims, including the first man to swim across the English Channel. Already famous for his swimming feats, Captain Webb, the Shropshire-born record-holder, decided to tackle the Niagara River just below the Falls. Against all advice he dived into the 40 m.p.h. current on July 24, 1883, only to be swept helplessly through the rapids and drawn into the sinister whirlpool. He was never seen alive again.

Another challenger, Bobby Leach, was luckier when he "rode" the Falls in 1911. He encased himself in a cigar-shaped steel barrel which had been carefully cushioned inside. Despite the padding he was hurled about so violently that he became unconscious. The whirlpool held him for 18 minutes, tossing and turning him all the time before the barrel was swept into calmer water. When he was rescued it was found that his injuries were only minor ones. He suffered more serious harm when he slipped on an orange peel in an Auckland street! The accident necessitated amputation of the limb, and the man who had undergone the hazards of Niagara died in a hospital bed. Another attempt to conquer the cataract in a barrel ended in tragedy. In 1930, George Stathakis made the dangerous trip, but inexplicably had the barrel made of wood. It was smashed to pieces on the rocks at the foot of the gorge.

A Bristol barber who had himself encased in a similar barrel more than forty years ago, was wise enough to have it strengthened with iron bands, and even attached a 160 lb. iron plate to the base in order to prevent him from being turned upside down. He also wore a padded suit, yet these precautions did not save him. The barrel was dashed to pieces and the foolhardy barber was killed.

Women have tried to earn Niagara honours, but only one has succeeded. She was Mrs. Anna Taylor, who literally took the plunge in October, 1901.

She also used a wooden barrel, but it was an improvement on the one constructed for the ill-fated Bristol contestant. Hers was 4 ft. 8 in. high and measured 28 in. at the middle, but tapered at each end like an African native drum. Harness inside and an airtight lid were other safety ideas. A trial run was carried out with a cat inside. When this experimental trip killed the cat Mrs. Taylor would not heed advice about the immense risks involved if she tried to repeat the attempt herself. Moreover she refused to postpone her effort when bad weather turned the river into a seething cauldron. The following day she announced her determination to carry on with her arrangements although the water was still turbulent. She entered the barrel and cushions were squeezed around her body. After the lid had been battened down, air was pumped in through a valve. Mrs. Taylor was then launched by her manager and a group of

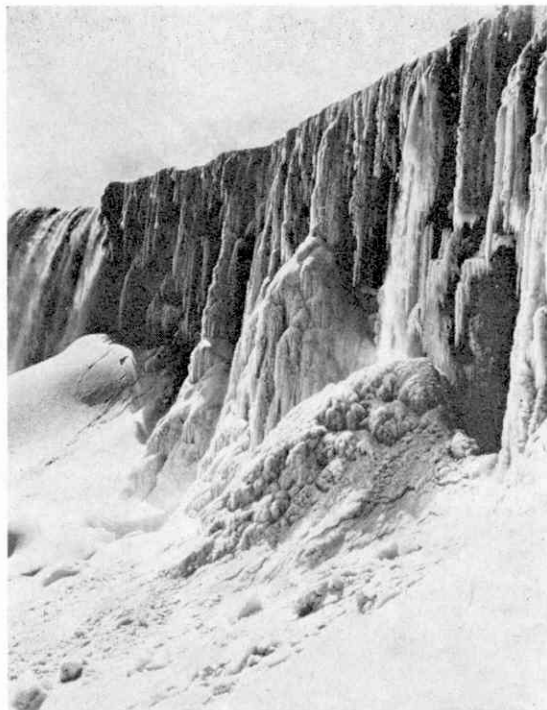

rivermen. They became still more disturbed when she tapped on the side and called out that the barrel was leaking. Even then she would not agree to cancel the attempt, and she went over the brink.

Thousands of sightseers flocked to the banks to watch, as the barrel hurtled the maelstrom. It disappeared for several minutes, but eventually bobbed to the surface near the rocky shore and riverside men rushed to retrieve it. Hurriedly removing the lid, they were greeted by a waving arm. Apart from a gash behind one of her ears, the intrepid Mrs. Taylor was uninjured by her ordeal. She was the first and only woman to shoot Niagara Falls and live.

Since 1951, Government authorities have instructed the police to prevent further attempts to perform such stunts. Yet this order could not be applied to the most remarkable of all escapes. In July, 1960, a schoolboy, Roger Woodward, fell into the river above the Falls and was carried towards the brink. By a chance in a million he was plucked from the water and survived without suffering any serious injuries.

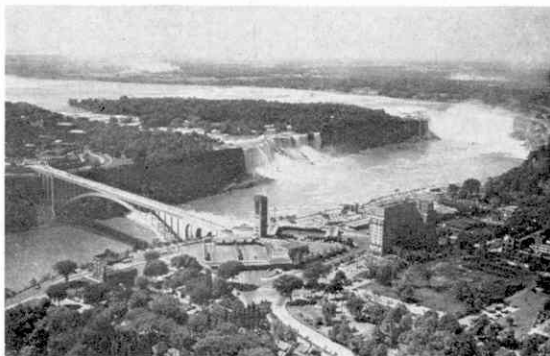

Above right: Winter brings an unusual spectacle, the vast amount of water becomes frozen and the flow just a trickle. Right: An aerial view of the Falls with the Canadian Horseshoe Falls on the right.

# COMBINE HARVESTER

## Part II

Described by  
*Clive Robins*

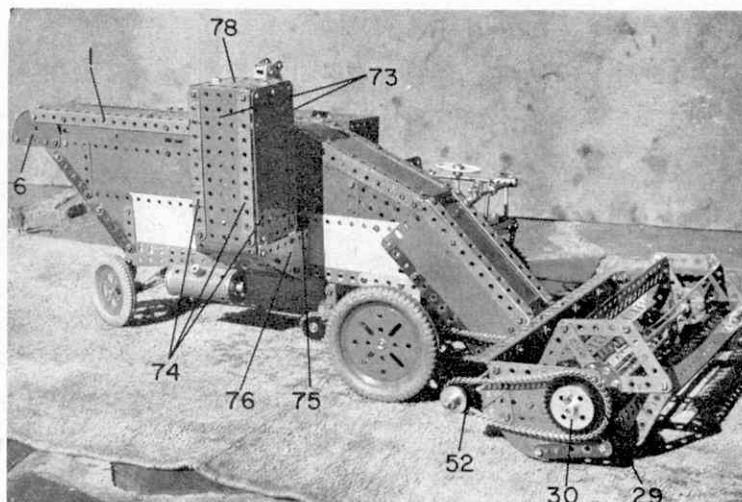

Now bolted to Double Angle Strip 34 are two  $3\frac{1}{2}$  in. Strips 41, angled inwards, and connected at their lower ends by a  $2\frac{1}{2} \times 1\frac{1}{2}$  in. Double Angle Strip 42. Journalled in the end holes in the lugs of this Double Angle Strip and in Corner Gusset 10 is the front axle supplied by two 5 in. Rods connected by a Coupling and held in place by Collars. Mounted on the axle are a 2 in. Sprocket Wheel 43 and a  $\frac{1}{2}$  in. Pinion 44. In mesh with the Pinion is a second  $\frac{1}{2}$  in. Pinion on a sliding layshaft supplied by a  $3\frac{1}{2}$  in. Rod journalled in the centre holes of the lugs of Double Angle Strip 42. Note that this Pinion is loose on the Rod but is held in place by Collars. Under normal circumstances the Rod is held steady by a Compression Spring, held in place by a Collar, working against the outside lug of the Double Angle Strip, another Collar preventing the Rod from leaving its bearings. The layshaft is moved by an Angle Bracket fixed to yet another Collar 45 mounted on the Rod. Bolted to the free lug of the Angle Bracket is a Rod and Strip Connector in which a  $\frac{1}{4}$  in. Rod 46 is held, this Rod passing through the base of the cab. A locking device to hold the layshaft out of its normal resting position, when required, is provided by a Coupling 47 on a Threaded Pin screwed into a Collar 48 on the front handrail. By turning the Coupling the Collar on the handrail can be freed to slide to the required position and then locked in place.

Running parallel to the layshaft is a  $6\frac{1}{2}$  in. Rod also journalled in Double Angle Strip 42 and held in place by Collars. Fixed on this Rod are a  $\frac{1}{2}$  in. Pinion 49 and a 1 in. Sprocket Wheel 50. When moved inwards, the Pinion on the layshaft should mesh both with Pinion 49 and Pinion 44. Sprocket Wheel 43 is connected by Chain to a 1 in. Sprocket on the Rod carrying Gear Wheel 9, while Sprocket Wheel 50 is connected to a  $\frac{3}{4}$  in. Sprocket on a Rod 51 journalled in two Cranks bolted one to the central body chute and the other to the appropriate end plate of the cutter shield. Another 1 in. Sprocket 52 is fixed on the Rod, as also is a  $\frac{3}{4}$  in. Flanged Wheel, the Sprocket being connected by Chain to Sprocket Wheel 29. The front road wheels, mounted on the ends of the front axle, are each supplied by a 3 in. Pulley fitted with a Motor Tyre.

Returning to the cab a rear-view mirror is supplied by a  $\frac{3}{4}$  in. Washer bolted to an Obtuse Angle Bracket 53 which is in turn bolted to the corner Coupling

incorporated in the handrail. The steering wheel is mounted on a  $4\frac{1}{2}$  in. Rod journalled in Flat Plate 31 and in a Double Bent Strip fixed to the underside of the Plate, Collars holding it in place. Mounted on the lower end of the Rod is an 8-hole Bush Wheel to which a  $2\frac{1}{2}$  in. Strip 54 is bolted. A  $1\frac{1}{8}$  in. Bolt carrying two free-running  $\frac{1}{2}$  in. Pulleys 55 is secured, as shown, to left-hand Girder 7 through its tenth hole from the front, two further  $\frac{1}{2}$  in. Pulleys 56 and 57 being mounted on Bolts fixed in the rear chassis cross member. A length of Cord is then tied to the left-hand end of Strip 54, is taken over lower Pulley 55 and round Pulley 57 to be secured to the Bolt locking right-hand Strip 14 to Strip 15. Another length of Cord is tied to the right-hand end of Strip 54, this being taken over upper Pulley 55, round Pulley 56 and tied to the Bolt locking left-hand Strip 14 to Strip 15. Both these Cords should be as taut as possible to keep steering play to a minimum.

Situated behind the cab is the large grain hopper, this being built-up from two  $5\frac{1}{2} \times 3\frac{1}{2}$  in. Flat Plates 58 connected by four  $2\frac{1}{2} \times \frac{1}{2}$  in. Double Angle Strips to two  $3\frac{1}{2} \times 2\frac{1}{2}$  in. Flanged Plates 59. Bolted to each Flat Plate are two  $3\frac{1}{2} \times 2$  in. Triangular Flexible Plates 60 and a  $4\frac{1}{2} \times 2\frac{1}{2}$  in. Flexible Plate 61. The lower ends of these Plates at each side being connected together by a "U"-Section Curved Plate 62, the joints being overlaid by  $2\frac{1}{2}$  in. Strips 63. Attached by an Obtuse Angle Bracket to each Flanged Plate 59 are two  $3\frac{1}{2} \times 1\frac{1}{2}$  in. Triangular Flexible Plates 64, these also being attached to Triangular Flexible Plates 60 by ordinary Angle Brackets held by Bolts 65. The outlet pipe for the grain is represented by a 5 in. Rod held in the boss of a small Fork Piece 66 attached to a  $\frac{1}{2}$  in. Reversed Angle Bracket bolted to outside Strip 63. Secured on the Rod are a Collar and four Couplings, the lower Coupling being attached to the side of the hopper by an Angle Bracket, then a Chimney Adaptor with Sleeve Piece are mounted on the upper end of the Rod and held in place by a Collar inside the Chimney Adaptor. The completed hopper is fixed to the main body by two  $1 \times 1$  in. Angle Brackets 67.

A load chute for the hopper is built up from two  $5\frac{1}{2}$  in. Angle Girders 68 secured to each other by Double Brackets to form a box section, the resulting box being attached to Angle Girder 32 by a Double Bent Strip and to the back of the hopper by a Reversed

Angle Bracket 69. Note that this Bracket is attached to the chute by a  $\frac{3}{8}$  in. Bolt which also serves to fix an Angle Bracket to the opposite side of the chute. This Angle Bracket is bolted to the central body section of the model. Attached to the top of the chute are two Fishplates 70 to which a large Fork Piece is bolted, an Adaptor for Screwed Rods being held in the boss of this Fork Piece.

In the case of the fuel tank, a Cylinder 71 is attached by two Obtuse Angle Brackets to right-hand Girder 7, the Brackets being spaced from the Girder by Collars on the shanks of the securing  $\frac{3}{8}$  in. Bolts. Wedged in the ends of the Cylinders are two  $1\frac{1}{8}$  in. Flanged Wheels 72 on a  $3\frac{1}{2}$  in. Rod, while a filler cap is provided by an Adaptor for Screwed Rods fixed in the side of the Cylinder.

The rectangular "tower" at the right-hand side of the model is made up from four  $5\frac{1}{2} \times 2\frac{1}{2}$  in. Flat Plates 73, connected together at the top by two  $2\frac{1}{2} \times \frac{1}{2}$  in. Reversed Angle Brackets, the securing Bolts fixing  $5\frac{1}{2}$  in. Strips 74 down the long edges of the Plates. A  $3\frac{1}{2} \times 2\frac{1}{2}$  in. Flanged Plate 75 is attached to the lower end of the tower by two  $2\frac{1}{2} \times \frac{1}{2}$  in. Double Angle Strips, the securing Bolts also holding four Fishplates in position. Bolted to these Fishplates, one at each side, are two  $3\frac{1}{2} \times 2$  in. Triangular Flexible Plates 76. Note that the outside flange of the Flanged Plate is also bolted to the lower corner of outside Flat Plate 73 at the same time fixing a  $4\frac{1}{2} \times 2\frac{1}{2}$  in. Flexible Plate 77 in place. This Plate is curved under to follow the contours of the Triangular Flexible Plates, being attached to these Plates by a  $2\frac{1}{2} \times \frac{1}{2}$  in. Double Angle Strip.

Finally, the top of the tower is enclosed by a  $2\frac{1}{2} \times 2\frac{1}{2}$  in. Flexible Plate 78 attached by another  $2\frac{1}{2} \times \frac{1}{2}$  in. Double Angle Strip bolted to two opposite Flat Plates 73, then the tower is braced by a  $1\frac{1}{2}$  in. Strip bolted between the tower and an Angle Bracket secured to the side of the body.

When completed, the Combine Harvester will operate very impressively, driving in both forward and reverse with the harvesting sail unit either in motion or stationary, thanks to the forward/reverse lever on the Power Drive Unit. In view of the position of the Unit, however, the builder incorporated a separate stop/start switch in the cab, this switch being a commercially produced item and mounted inside a Channel Bearing 79 attached to the cab floor by Angle Brackets. It must be stressed that this is an advantage but is by no means essential.

## PARTS REQUIRED

3-1	4-20	4-62	1-160
16-2	2-20a	9-63	1-163
10-3	1-20b	2-63d	1-164
5-4	1-21	4-70	2-173a
29-5	4-23	1-94	1-185
6-6	1-24	2-95	5-188
10-6a	2-24c	3-96	4-189
6-8	4-26	1-96a	6-190
5-9	1-27a	6-103a	4-191
6-10	250-37a	3-108	5-192
3-11	260-37b	5-111	5-197
39-12	19-38	4-111a	1-199
4-12a	3-38d	1-111c	5-200
9-12c	1-40	1-111d	1-212
1-13a	3-45	1-115	2-213
3-14	2-47	1-116	4-214
4-15	4-48	1-116a	4-215
3-15b	15-48a	1-120b	1-216
2-16	1-48b	2-125	4-221
3-17	2-52	1-126	2-222
2-18a	3-52a	1-126a	4-223
1-18b	3-53	2-142a	6-224
2-19b	22-59	2-142b	6-225
			1-Power Drive Unit.

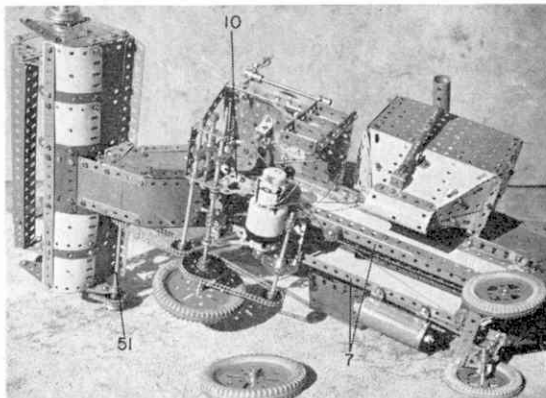

A general underside view of the model with one of the main wheels removed to show the underside of the driver's platform.

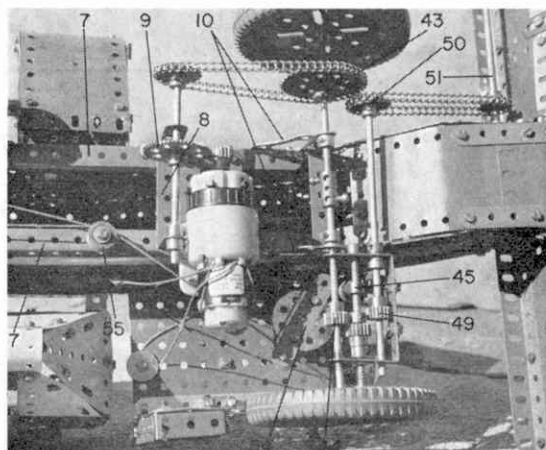

The construction of the gearbox and drive systems is clearly shown in this close-up underside view of the front section of the model.

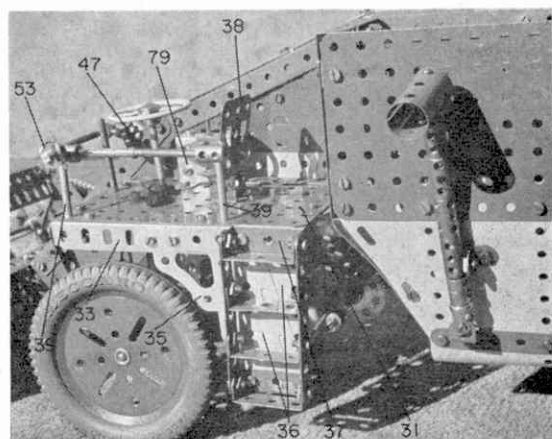

A close-up view of the driver's cab and access steps.



# A World War II Destroyer modelled in Meccano, & described for readers by Spanner

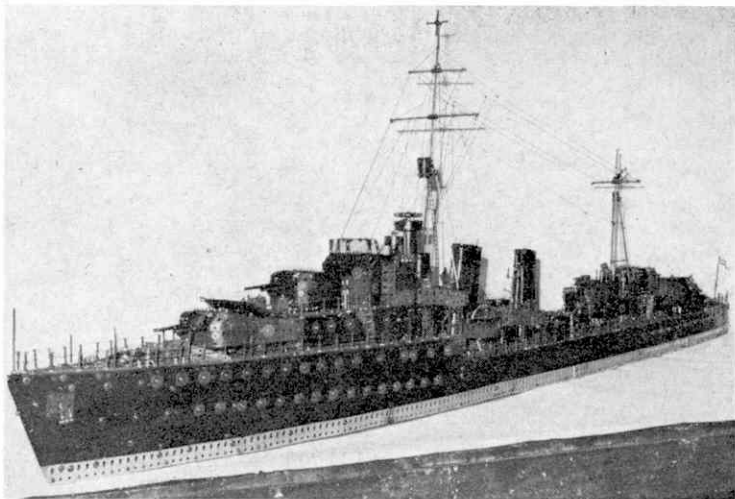

## H.M.S. COSSACK

AS MENTIONED in last October's issue of *Meccano Magazine*, one of the prize-winning entries in the 1968/69 Model-building Contest was a magnificent Naval ship which we promised to feature in detail in the following issue. Well, we were unfortunately unable to do so in November, but here it is now, and perhaps this is the best time for it, too, with our new Meccano competition, "Contest '70" being well under way. Looking at the model, I think you will agree that use of the word "magnificent" is not an exaggeration. It really is first-class and well worth the second prize in Section B it collected for its builder, Mr. Colin A. Burnett of South Oakleigh, Victoria, Australia.

Ships enthusiasts may recognise the model as being an authentic reproduction of the British Tribal Class Destroyer "H.M.S. Cossack" which was built in 1938 and sunk in the Mediterranean during 1941. Throughout the model's construction, Mr. Burnett took care to

keep authenticity as exact as possible and was able to succeed in this with the help of detailed plans of the original warship supplied by the Model Maker Plan Service. Just how remarkably successful he was can be seen from the accompanying photographs and the following general description, the latter taken from comprehensive details supplied by Mr. Burnett, himself.

With the overall length, beam and height to the mast top being respectively, 7 ft. 8 in., 9½ in. and 2 ft. 5 in., the model is by no means small, despite being produced to a scale of 1 : 48 or 1 in. to 4 ft. No less than 3,120 Nuts and Bolts were used in its construction which, incidentally, took over a year to complete. The main frame is made up of 24½ in., 18½ in., 12½ in. and 9½ in. Angle Girders, with additional 9½ in. Angle Girders running across the beam, these last being reduced in length towards the bow and stern, as required, and braced diagonally so that the whole model can be supported by one central point.

Mr. Burnett goes on to say that, after the frame was completed, Strip Plates and Strips, etc., were arranged over the top of the Girders to serve as the hull. The waterline is represented by a Flat Girder, while the handrails are 1½ in. Bolts, and tarpaulin supports on the fore and quarter decks, 2 in. Screwed Rods. All portholes are represented by ¾ in. Washers while the foredeck fittings consist of bollards supplied by Anchoring Springs for Cord between Washers, and

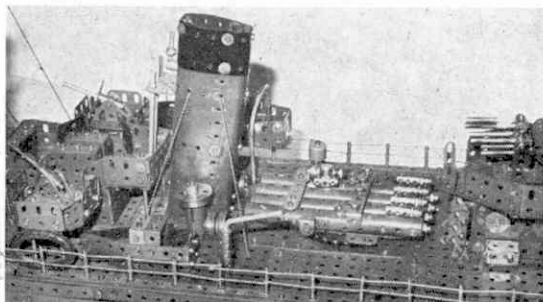

Above: One of the many reasons why this model won a prize in the last Model-building contest was because ship models are not often built in Meccano, but the superb detail in it must surely have helped it on its way. Left: a close-up view "amidships" showing the aft funnel and the torpedo tubes.

Right: a view of the stern end of the Destroyer from immediately behind the aft funnel. Detail is plentiful and extremely accurate.

a capstan supplied by a  $\frac{1}{2}$  in. Pulley between  $\frac{3}{8}$  in. Washers. Sprocket Chain serves as anchor chain whereas the anchors themselves each consist of three Collars on a  $\frac{3}{8}$  in. Bolt with a cross piece supplied by two Centre Forks.

In the case of the superstructure, the foredeck house and bridge are constructed from Strip Plates strengthened by Girders, and a number of Triangular Plates. Bridge fittings such as torpedo sights, voice pipes and recorders are mostly produced from Double Brackets, Rod Sockets and Collars, etc., although the bridge and after deck compasses are each supplied by a Chimney Adaptor, in the centre of which a  $\frac{1}{2}$  in. Pinion is mounted.

Both funnels are built-up on a frame of Boilers,  $2\frac{1}{2}$  in. diameter Cylinders and Sleeve Pieces. Around each funnel is a  $1\frac{1}{2}$  in. wide band, signifying that the ship is the flotilla leader, produced from  $5\frac{1}{2} \times 1\frac{1}{2}$  in. and  $2\frac{1}{2} \times 1\frac{1}{2}$  in. Plastic Plates. The quarter deck sports a number of "depth charges", neatly stacked in threes and represented by Couplings. More bollards are also included as well as hatches represented by

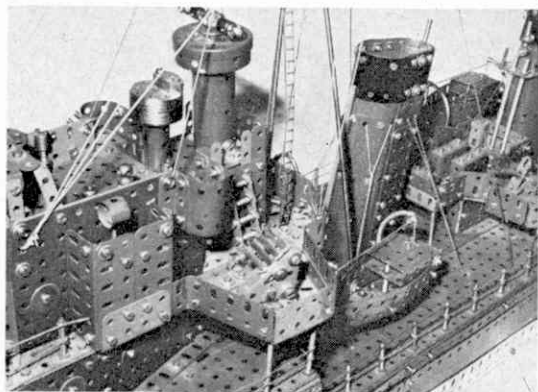

Strips and Fishplates. Several torpedo tubes are present, these being built-up from Sleeve Pieces and Chimney Adaptors with a number of Elektrikit parts to represent the controls. They are mounted on Ball Thrust Bearings.

Gun mountings swivel on 3 in. Pulleys fitted in the centre with Wheel Flanges and a number of Meccano  $\frac{3}{8}$  in. diameter Balls. The guns themselves are constructed from Flat Girders,  $1\frac{1}{2} \times 1\frac{1}{2}$  in. Plates, Curved Strips, Formed Slotted Strips and Flexible Plates. A number of  $1\frac{1}{2}$  in. Wheel Discs serve as the director, the top Disc being shaped as required.

No less than nine hanks of Cord were used for the rigging which is as near to correct as is possible from small plans. The ensign and bunting are supplied by painted paper stuck to cords as required.

The guns, torpedo tubes and range finder swivel realistically, the guns turning from port to starboard, stopping at the end of the traverse for about 10 seconds, then they elevate and descend prior to turning again. These operations are made possible by a special mechanism which makes use of two pre-war Rack Segments

Above: a detail shot "amidships" showing the bridge and the funnels. Note the small litebeat, suspended from its davitts, which in real life, might well have doubled as a harbour launch. Right: a close-up view of the bow section of the model showing the main forward guns and the anchor chain windows. The anchor chain, itself, is represented by pre-war Meccano Sprocket Chain.

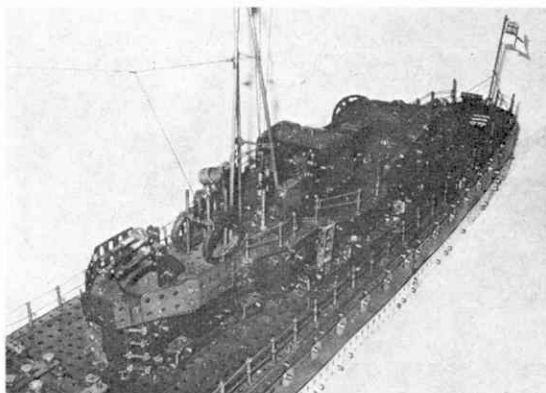

bolted to a Face Plate attached to a Rod which turns through 270 deg. then reverses using the usual Worm Gear/Gear Wheel reversing mechanism. The Rack Segments give only 180 deg. of turn, the remainder of the Rod's 270 deg. turn being used to raise and lower the guns at the end of each turn of the turrets. This raising and lowering movement is actuated by a cam, acting on a  $\frac{1}{8}$  in. diameter Axle Rod located inside a  $\frac{3}{8}$  in. brass tube which is in turn attached to the turret as a pivot. The guns are constructed on either side of a Channel Bearing which holds a  $\frac{1}{2}$  in. Pinion in its centre. The  $\frac{1}{8}$  in. diameter Rod carries a Worm Wheel so arranged that, when the Rod is raised by the cam, the Worm acts on the Pinion to raise the guns. The cam is geared through a 1 in. Gear and a Rack Segment and is turned to come into operation when the first set of Rack Segments disengage.

The whole ship is centrally pivoted on one point under the bridge and about  $4\frac{1}{2}$  in. above the water line, this pivot being produced from two cups and a  $\frac{3}{8}$  in. steel ball bearing. Very little effort is required either to roll the ship to port and starboard or to pitch the ship fore and aft and it is so finely balanced that even the weight of the guns traversing will swing the ship to port or starboard depending on the direction the guns are pointing.

All operations come from one gearbox driven by a mains motor built in to the body of the ship, the whole ship being mounted on a  $4\frac{1}{2}$  in. high stand fixed to a  $8 \times 1$  ft. baseboard.

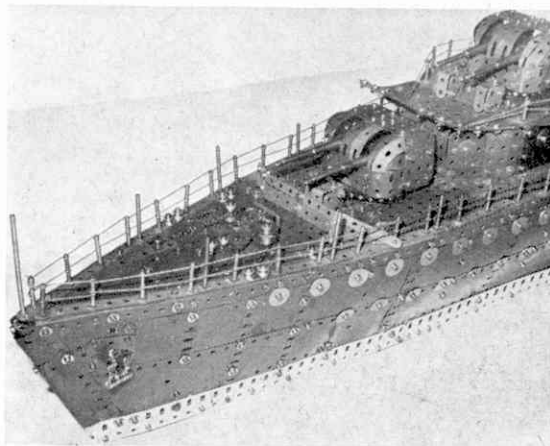

# THE FIRE-WALKERS OF SOUTH INDIA

by Richard Lee

EVERYBODY HAS heard of the Indian Rope Trick,—a non-existent fantasy of the East. Few people have heard of the fire-walking ceremonies—and these do exist! On one day in every year the Canaris people of South India demonstrate mind over matter by walking bare-foot up a flaming trench, about 40 ft. in length, and emerge unscathed!

A tea-planter friend of mine once asked me if I cared

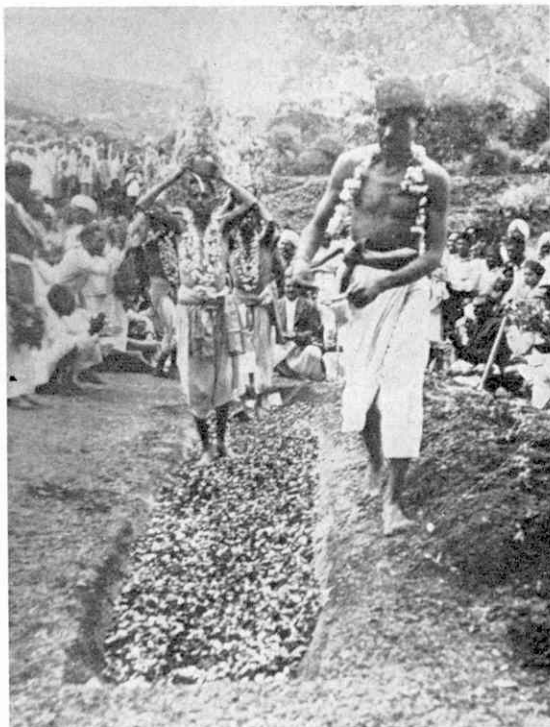

to witness the fire-walking ritual which is an annual religious feast of the Canaris South Indian. I accepted his invitation readily, as it was a ceremony not practised on the tea-estate which I was managing at the time. I had seen the Thai-Pongal, a feast involving bodily mutilation, on two or three occasions but was told that this was tame stuff compared to the ordeal by fire.

On the appointed night my friend led me to the ceremonial ground. The area, usually a field, had been transformed into a small town of temporary huts and sideshows. There were thousands of Canaris people present—many more than were employed on his estate—the others obviously having travelled from miles around. We were received in style at the temple and offered the usual gifts of welcome; a garland of flowers to be worn around the neck and a plate of fruit with a packet of cigarettes and a box of matches. A drummer was summoned to beat a welcome tattoo, which he did with ear-splitting efficiency, drumming for about 20 minutes at such speed that I could only see a blur from his elbow downwards. We were informed that he was the best drummer locally and would keep up his rhythm throughout the night without pausing for rest. The promise was subsequently fulfilled.

Leading to the temple steps a shallow trench had been dug, about a foot deep by some three feet wide and about 40 or 50 ft. in length. Workers were stacking loads of firewood into this trench in preparation for the kindling of the fire. We looked around the encampment. Small stalls were selling spicy foods and cool drinks. Crowds milled around us with a sort of fair-ground atmosphere. To one side an open-air theatre and stage had been erected and a traditional drama was in progress. Indian traditional dramas do



not move at a very fast pace and usually take several hours to run their course. The squatting audience was quite enraptured, however, although it was quite the thing to get up for a meal and return some time later—one would not miss a great deal of the action by so doing. The drama was accompanied by a small Indian band of peculiar instruments; a hooter that played a single note, a single stringed type of violin and a sort of piano-accordion laid on its side, the bellows being worked by a small boy.

We were told that the fire would be kindled about midnight and worked up to its most intense heat by the first break of dawn at which time the professional firewalkers would commence a journey from the local riverside, where they would have had a cleansing bathe, and lead a procession to the fire trench. They would be carrying large umbrella-like objects which the interpreter could best describe as the 'God's furnitures'. On arrival at the trench the firewalkers would then walk through the red-hot bed of ash bearing the God's furnitures as they did so, to present them to the priest at the temple steps. They would not be harmed by the fire, we were assured. At midnight we saw the great fire kindled and then went off to snatch a few hours sleep before the climax of the ceremony was due to start at dawn.

In the morning, just before dawn, we again visited the festival field. We were again ceremonially welcomed with fresh garlands and more fruit and cigarettes. Sundry drumming had been continuous throughout the night and we saw our local 'champion' still hard at it and apparently with undiminished vigour. We were told that the procession would be soon arriving. We had been given chairs to occupy at the side of the molten ash pit, for the huge cords of wood had now been reduced to small pieces of red-hot flakes, filling the pit so as to be level with the ground. Two strong men armed with fans of stout greenery now switched at the fire whipping up the heat and the searing hot air made me duck away and cover my face with my arm, even though I was about six feet or more from the side of the trench.

Shortly, to the accompaniment of drums and cymbal-like instruments, the procession arrived. The firewalkers bearing aloft the God's furnitures, they came to the fire trench and marched around it three times. I wondered whether the professional fire-walkers were in a trance or possibly drunk, for they had a rather "out-of-this-world" air about them. The orderlies again switched up the fire to produce the blistering heat; the leading fire-walker seemed reluctant to enter but was given a shove by those behind him. Then, fairly rapidly, they all walked through the trench in single file. All were bare-foot, indeed they wore only a scanty loincloth and thin vest. They carried the God's furnitures into the temple and left them there. At this point many of the local people followed through the fire trench themselves, most were ordinary everyday coolies of the estates. All again were bare-foot, and included many women.

I watched carefully but saw only one person step out of the ashes as if affected by the heat, and in no case did I see anybody with any sign of physical damage to their feet. Nor did I see anybody nursing their feet or limping after their experience. The local

**Heading:** The firewalkers walking through the red hot pit, carrying their offerings to the temple steps. **Left:** One of the sideshows—two Himalayan bears dancing.

**Above right:** The Indian people dress in traditional costumes to perform religious plays.

**Right:** An acrobat in a sideshow hangs by his toes to a roll on the drum.



people will tell you that it is simply a matter of faith, and seem to see nothing remarkable about it.

Discussing this matter afterwards I have heard of several possible explanations. Of course the natives' feet have a very tough skin, for they wear no shoes at any time, but the upper sides of their feet are little if any tougher than our own, and I saw many people tread in the fire to the depth that their feet were completely covered by the red hot ash at each step. I have heard that one can soak the feet in a solution of alum to render them safe to a brief encounter with fire. The professionals may have done something like this at the river, but I doubt it. The local people were certainly not thus engaged prior to entering the fire, although the fire had become appreciably cooler by the time the last stragglers had gone through. If faith is the answer to this ceremony of mind over matter, then I am quite satisfied to leave it to those who possess the faith for I would have to be sorely pressed indeed before I would be persuaded to take my chance along the trench of fire.



# BATTLE

by Charles Grant Part XXII  
Reconnaissance in force

THE NARRATIVE of a battle such as the one we are about to fight, that is, one in which considerable forces are involved and which covers a much larger area than those we have previously considered, can quite easily become overlong and consequently pretty tedious, but I shall try to make it as concise as possible, without omitting any relevant detail, in the hope of maintaining the reader's interest.

First then, the wargame table, whose topographical details can be studied in the diagram, measures 9 feet by 7 feet, which is about as large an area as can be conveniently fought over. It is possible to reach the centre with maybe a bit of a stretch when moving troops or vehicles and, while a long arm is an advantage, even players of modest stature can, if need arises, stand on a small box or chair to assist manoeuvring in the middle of the "battlefield". The terrain is not tremendously complicated, being a generally flattish sort of countryside, dotted with small woods and farm buildings, a feature of the latter being the stone walls of the cattle pens. The river may be crossed only at the two bridges shown, while the hill towards the east is wooded, precipitous and impassable to all troops and vehicles.

To make the thing a little more interesting, and indeed to lend a degree of realism as well, it is proposed to give an account of the fight from one point of view only, that of the RED general, who will initially be in relative ignorance of what he expects to find in the course of the reconnaissance in force which he has been ordered to carry out. The general scheme is that RED, commanding the force whose composition we shall detail in a moment, has been instructed to make a probe from the south towards the angle of the river, in the vicinity of which BLACK troops have been active, although exactly where and in what strength are unknown factors. He—the RED commander—is to drive ahead as aggressively as possible against what is believed to be a BLACK position, to penetrate it if possible, or at least to ascertain in some detail its strength and extent. To this end RED is given a task force made up as follows—one infantry battalion, a section of tanks—two in number—and a battery of field artillery. The battalion is, of course, the motorised infantry one whose composition we have been at some pains to describe—HQ Company (with all its support components—mortars, A/T guns and so on); the field battery has its stipulated two guns, F.O.O., etc., while the tanks—this is a vaguely Muscovite army—are T34/85 types. This is the force then which, coming from the south, will debouch on to the table, on the roads actually, at the points marked 'x', 'y' and 'z', ready, willing and, it is hoped, able to take on whatever awaits in "terra incognita".

Having studied briefly the terrain, RED decides to take advantage of all three roads, and to advance on a wide front, the axis being the centre road. Consequently, on the first move his troops moved on to the table from the three points—'A' Company of the infantry battalion at 'x', 'B' Company at 'y' and 'C' Company at 'z'. Closely following 'B' Company came the Battalion Headquarters Company, RED

himself being with the leading vehicles of 'B', together with that highly important character, the Forward Observation Officer of the Artillery Battery. The guns themselves, plus the two tanks, were held in reserve just off the table south of LONG FARM. At this point the two generals—BLACK and RED—carried out the normal ritual of determining visibility, each throwing a dice. The result was a total of ten, so providing visibility of 25 inches and 35 inches for 'unaided' and 'aided' respectively. It must have been a fairly clear day—both generals appeared to be pleased with the result.

At the conclusion of the first move, then, RED has pushed 15 in.—half-track speed on roads—up all three roads, his Command Car is ensconced behind the buildings of LONG FARM, and the leading elements of his Headquarters are just coming on to the table to join him. His idea was to make the farm his headquarters for the time being. About to make his second move, however, RED is told by BLACK "Hold it!" The latter throws a dice, which comes up '6' and with barely concealed glee he announces to RED that his F.O.O. is in radio contact with artillery support and is about to bring down fire upon the advancing RED forces. A few moments cogitation by RED results in the conclusion that there are only two points where the confounded enemy observation point could be located—either in ROUND WOOD or the little COPSE—and the former, being located more centrally, is the more probable. His thoughts, however, are interrupted by BLACK's placing his perspex burst pattern device plumb on the column of vehicles by LONG FARM and stating that this is his target. His 'ranging' throw, unluckily for him, was a very inadequate '2'. He made no comment, but if looks could have killed . . . !

Wisely deciding that the next move might prove BLACK's gunfire to be more accurate, RED decided to occupy Move 2 with organising the dispersal of the considerable mass of vehicles about LONG FARM in an endeavour to minimise the possible effect of the enemy artillery fire. This he did, spreading the half-tracks and so on as widely apart as possible, and directing the support sections to take position behind the stone walls and the small wood on the side of the road opposite the farm.

At the same time 'C' Coy. continued its advance along East Road, taking the right hand fork, with the aim of skirting the eastern side of the wooded hill. One half-track from 'A' Coy. moved off West Road towards the COPSE—it was just possible that the enemy F.O.O. was therein—although the arrival of the half-track close by produced no enemy reaction. To BLACK's chagrin, when it was time for him to fire, his ranging shot again failed, and to RED's satisfaction, his scattered vehicles remained quite unscathed.

However, RED's advance towards the COPSE had brought almost all the farm buildings to the north—call it BRIDGE FARM—into visibility, causing BLACK to disclose—and set down on the table—a fairly substantial force of infantry round the farm, including bazookas and mortars. Also—and this intelligence was of considerable value to BLACK—two Mark IV tanks, armed with the 'long' 75, could be seen, one on the road between the farm and RIVER WOOD, and one in the farm itself. Infantry could also be seen in RIVER WOOD, although in what strength could not be exactly determined, BLACK declaring that they were concealed. (As such, of course, they were ineffective, having to be set down before becoming operational).

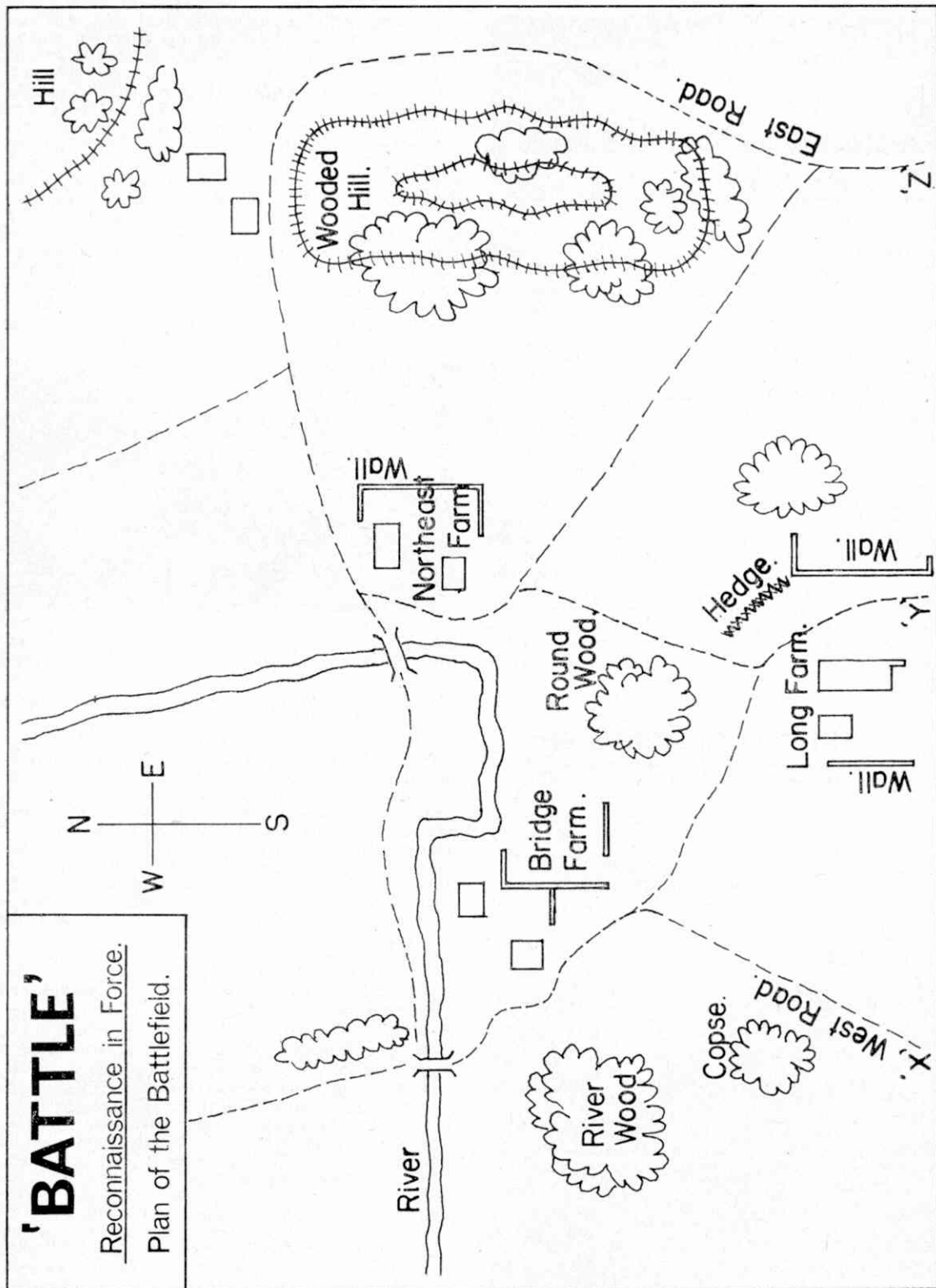



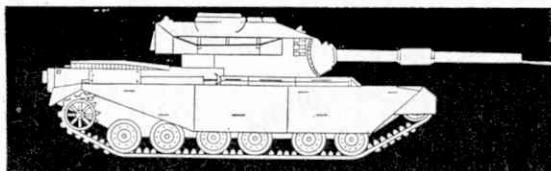

## MILITARIA A REVIEW BY CHARLES GRANT

ALTHOUGH NOT the most popular tank with wargamers, the American-designed M.3—the Grant/Lee—is a ‘must’ if one is fighting desert-type battles and wants to have authenticity as regards armoured fighting vehicles. AIRFIX have now produced such a tank in their OO scale, following the same admirable plan as was adopted for their earlier Russian T.34, that is, the provision of two different turrets for the same chassis. This gives either the U.S. General Lee, or its British counterpart, the General Grant. I thought that the finished model is a particularly good one, with all the massive—dare I say clumsy—appearance of the original. Even its most fervent admirers of the Grant could hardly say it was tremendously attractive in style and design. On the Airfix model detail of moulding is well up to the customary Airfix standard, and the tracks are of the usual flexible type. Painted with a little care, it has a most realistic appearance. I have always thought it odd, by the way, what an extraordinary thing it was to install the tank’s heavy main armament in a side position with very limited traverse. There must have been some reason for this, I suppose. Anyway, I like the Grant/Lee model very much, and it is well worth the 2/9 it costs.

### British and American Tanks of World War II

The complete illustrated history  
of British, American and  
Commonwealth tanks, 1939-1945

Peter Chamberlain and Chris Ellis

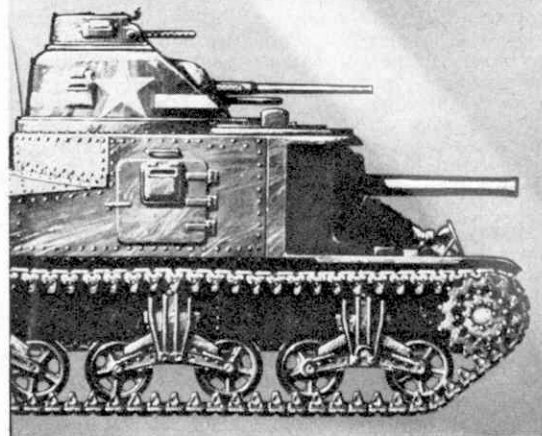

In point of fact, absolutely everything that one could wish to know concerning the Grant, as well as every other British, Commonwealth and American tank of World War II can be found in a most desirable book just published by **ARMS AND ARMOUR PRESS** (677 Finchley Road, London N.W.2). These days this firm seems to be an absolutely inexhaustible source of the most interesting and valuable books for the wargamer, the military modeller and for anyone with any sort of similar interest, and “British and American Tanks of World War II” is no exception. Enthusiasts have quickly realised that anything written by the well-known partnership of Peter Chamberlain and Chris Ellis bears all the hallmarks of authenticity and authority, and this magnificent volume is probably the best thing they have as yet produced. It is of a largish format, about 11 inches by 9 inches or thereabouts, and its 222 pages contain a wealth of inform-



Above: A realistic photograph of the new Airfix Grant/Lee OO model in action. An impressive addition to the range.

Left: A new book from Arms and Armour Press—a fund of information for the military collector.

ation about every sort of tank and military vehicle—special purpose jobs included—brought out by the relevant nations during the years 1939 to 1945. It contains hundreds of photographs—practically every page has at least one—together with the most exhaustive details of performance, armour, armament, and any other point you care to name. (I found the section of the Sherman tank and its variants particularly interesting and useful). For such a volume, the cost—105/-—is high but undeniably justified, and the publisher’s claim that it is “an essential work of reference” is perfectly correct. It is a worthy companion for the same firm’s “German Tanks of World War II”, that fine work by von Senger und Etterlin, and one can’t say better than that.

The **GARRISON** (now trading as **GREENWOOD AND BALL**, “Martinhoe”, East End Way, Pinner, Middlesex) continues to produce fresh additions to the line of ‘ancient’ 20 mm. metal figures for wargaming, and we show some of the most recent—an Egyptian infantryman, a mounted Gaul, a couple of Romans and two Greeks. The last two are really quite something, the detail of moulding of these tiny figures would do credit to models of a much larger scale—the horse’s head standard being supremely well executed. Unluckily—although this is not by any means a unique phenomenon in this day and age—the firm has had to increase prices a little. An infantry figure now costs 1/3 (instead of a shilling as before) and a cavalryman

Far right: An interesting magazine from a war game society—published bi-monthly by Bristol Wargame Society.

Right: One of the new military post-cards by artist Charles Stadden. Very impressive in full colour.

Below: Some of the latest 20 mm. 'ancient' figures from the Garrison—really excellent figures.

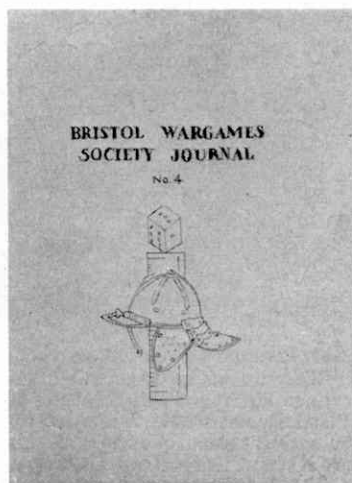

is now sold at 3/-. Even so, this is not by any means excessive considering the quality of the figures. It is interesting to note that the firm promises to break into other periods in the near future—probably the Napoleonic era. These should be worth seeing if they are of the same standard as their 'ancient' brethren.

Some time ago I referred to the possibility of uniform postcards by **CHARLES STADDEN** being published, and now I have received the first set of six cards. They are printed in full colour and, as I say, the artist responsible is Charles Stadden, the designer of the celebrated Norman Newton figures, who is also a first rate artist in his own right. The example reproduced shows the very high quality of the cards, which—a very useful departure, this—give on the back of each details of the sources from which the uniforms are drawn, a good idea for the enthusiast who would like to pursue further research in the subject himself. The first set is a sort of 'pot-pourri' of different types—they are all British, of course—unconnected with each other, and consisting of representatives of light cavalry, infantry and the Royal Waggon Train, all at different periods ranging from 1798 to 1858. Published by K. G. WYNN and CO., 42 Esher Drive, Littlehampton, Sussex, at 8/6 the set, they are good value for the military enthusiast.

Many of the numerous wargame societies and clubs

now existing all over the country produce their own magazine, and of them one of the best is the Journal of the **BRISTOL WARGAMES SOCIETY**. Stapled and bound with linen-tape, this is a very well designed and enterprising bit of work and says much for the enthusiasm and dedication of the society's members. The number I studied contained well-written articles on the Persian invasion of Greece in 481 B.C., the Hundred Years War, an illustrated study of Marshall Prince Poniatowski, and, believe it or not, a wargame based on a western gunfight! This is about the most unusual and 'way out' game I have ever come across, with the different gunfighters graded, according to ability and experience I suppose, as 'professional', 'average' and 'novice'. I don't suppose the last can be very fast on the draw. Anyhow, Britain's 54 mm. "Swoppet" cowboys were used for this game, assuming the identities, among others, of such notable characters as Bat Masterson, Jesse James, Virgil Earp and so on, although I'm not exactly sure which were 'baddies' and which were 'goodies'. Nevertheless the account of the action was certainly an exciting one, and, in common with the rest of the magazine's contents, I read it with great pleasure. The journal appears every other month, and the yearly subscription is only 10/-. Secretary is Mr. Mike Blake, 102 Cotham Blow, Bristol, BS6 6AP.

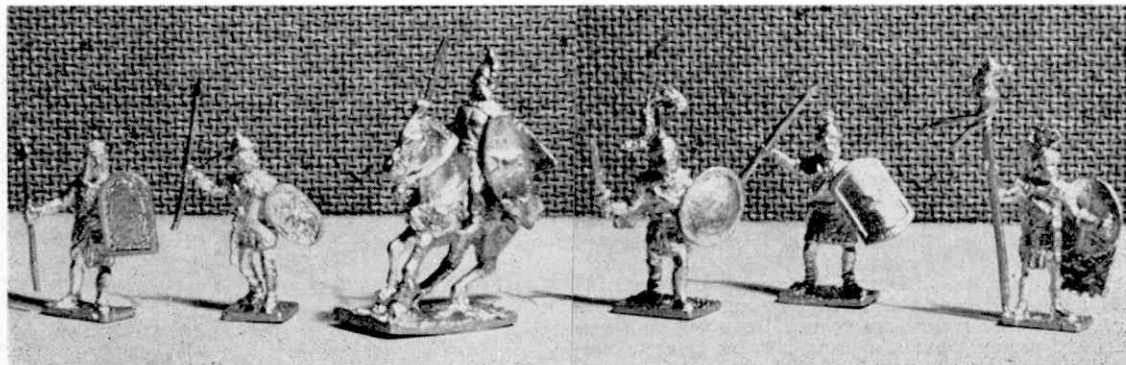

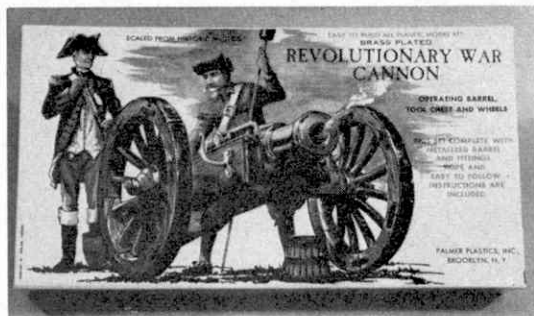

### Revolutionary War Cannon

We start off this month with a very nice plastic cannon kit from Palmer Plastics Inc. Although Palmer Plastics are an unknown name to most of us, you can be sure it's good quality stuff—the British distributors are Richard Kohnstam Ltd.

The kit, containing 45 parts, is very easy to construct. The assembly instructions are clear, and are well illustrated by detailed drawings. Some of the parts are moulded with a simulated wood grain, so when you paint these use a thin coat of paint so that the wood grain can still be seen.

Two small criticisms: firstly the kit is moulded in grey, which is not used at all in the colour scheme. This is odd, because usually a kit is moulded in a colour that is suitable for the finished model. Secondly, the metal parts are brass plated, which are very shiny and don't look very authentic. Still, as we said, these are only minor faults and do not defect the appearance of the model in any great way. The recommended retail price for the kit is 16/6d.



### Helix Junior Design Engineer

Winter with its short, cold and often wet days severely limits any outdoor activities that some of our younger readers might pursue. The many hours spent indoors are times when a child's creative ability is used more than usual. To help increase this ability Helix International (Producers of many educational toys) have recently introduced a toy designed to keep an imaginative boy, who is interested in designing and drawing, occupied for hours.

Called the Junior Design Engineer, the kit consists of a strong drawing board 12 in. x 9 in., clips, a graduated T-square which can be used by a left or right-handed person, pencils, a protractor, set squares, compasses, and an illustrated pamphlet containing many

# HAVE YOU SEEN?

ideas for putting the ideas into use.

When we received this set for review we were surprised to find that it costs a very modest 19/11d. We're sure that with a little care the set will last many years, and even if a piece does accidentally get broken, you can easily obtain a replacement from any stationers or toy shop where Helix toys are sold.

Helix International Co. Ltd. are stationed in Lye, Stourbridge, Worcs, and their products can be obtained, as we mentioned above, from stationers and any good toy shop.



### "MATCHBOX" 1930 Packard Victoria

Remember in the December issue of *Meccano Magazine* we reviewed a Rolls-Royce Silver Ghost, a member of the "Models of Yesteryear" series? Well already, only four weeks after we published that feature, "MATCHBOX" have released another model in the series. This one is the 1930 Packard Victoria, which was one of the most expensive cars in America in its day, and by looking at the model you can easily imagine why this was so.

Measuring just over four inches in length the car is a mass of well produced detail. Under the removable top is a completely detailed interior including a steering wheel, foot pedals, instrument panel and two large bench seats. The body sports 'gold-plated' windscreen frames, radiator, headlights, fenders and rear luggage carrier. Two spare wheels are situated

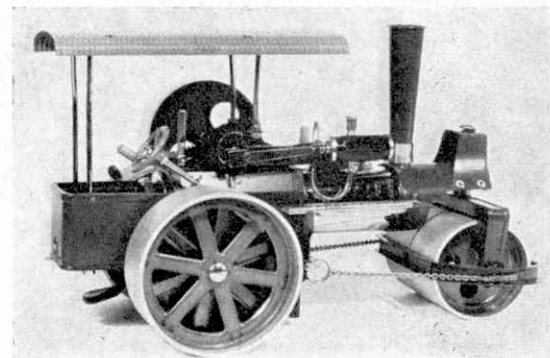



in the front wings and a trunk is fitted to the back.

The only criticism we have of this model is that the colour scheme is exactly the same as the Rolls-Royce, which is a bit disappointing if you have both models, but still, it is very handsome, which compensates for this.

### Wileco Steam Engine

A photograph of any sort especially the rather small one on this page, just cannot do justice to the superb Wileco Steam Engine!

The model measuring 12 inches in length, eight inches in height and weighing 3½ lb., is a perfect example of a German precision toy. It is of course, a genuine miniature steam roller, with a boiler capacity of approximately ½ pint, giving it a running time of nearly half-an-hour.

Heat is supplied by methylated spirit tablets, housed in a removable container underneath the cab end of the boiler, which incidentally has a clear end section in the cab to give an instant sighting as to the amount of water contained in it.

The model can run both backwards and forwards, speed in either direction being governed by a regulator fitted on top of the boiler, and outside the cab. A small lever over the left rear driving wheel can disengage the wheels, allowing the steam unit to run separately. A small pulley fitted to the fly-wheel allows the unit to drive any separate models (ideal for Meccano enthusiasts). Steering is per full size steam roller practice, i.e. a hand-wheel in the cab turning the front roller via a worm drive and chain.

Overall the model is very robust and is finished in bright red and green with chromium plated boiler and nickel-plated fittings. The Wileco roller is expensive at £16.10.0, but this model will last a life-time and probably longer, and certainly provides something very different for the practically minded youngster.

The distributors are Richard Kohnstan Ltd., 13-15a High Street, Hemel Hempstead, Herts.

### Corgi Astro 1 Experimental Car

A car which is very much a focal point in the automobile industry at the moment is the experimental Astro I built by Chevrolet. This futuristic car is a mere 35½ inches high and is completely streamlined from front to back, slightly tapering at both ends.

Corgi Toys were very quick off the mark to produce this amazing car in model form, and a very impressive model it is too. The main feature is definitely the hinged rear canopy which when lifted raises with it the two seats. Sitting very elegantly in the passenger seat is a lady wearing a gold lamé gown, and in the driver's seat a gentleman in a white tuxedo. Also under the canopy, behind the seats, is the air-cooled V6 engine but you can only just see it!

Other features include aircraft-type steering controls, fat rear wheels, rear-view periscope mirror simulation and gold plated racing mirrors. The model, measuring a little over 4 inches, is finished in blue with gold bonnet, and costs 8/11d.

Corgi Toys, produced by Mettoy Playcraft Ltd. of Euston Centre, London, N.W.1. are available from toy shops everywhere.

Top left: The simple-to-build Revolutionary War Cannon from Palmer Plastics. Centre right: The handsome Packard Victoria by "MATCHBOX". Centre left: Ideal for the young draughtsman, the Helix Junior Design Engineer. Left: The superb Wileco "Old Smokey". Above right: The experimental Astro I produced by Corgi. Right: Monogram's latest "Instant Fun Car" the Dragon Wagon.



### Monogram's Dragon Wagon

Every time we receive a new "Instant Fun Car" from Monogram Models Inc., Illinois, U.S.A., we that this is going to be the last, but then a few weeks later along comes another, and we wonder 'How do they do it?'

Each fascinating model is as good as the next, although we do have our own personal favourites such as Tijuana Taxi, Pie Wagon, Trantula, Red Baron and this, one of the latest releases, the Dragon Wagon.

The Dragon Wagon has a circus theme (as can be seen from the accompanying photograph). The cage, we are told, is from an old time circus animal lorry, and is decorated with ornate scroll work which looks very effective when painted up. The dragon imprisoned in the cage is, we think, a little out of proportion, with a great fat body and a very skinny neck, but it is good enough to create an impression of ferocity. Other circus novelties included in the kit are a tiger-tail gear stick, a monkey radiator ornament and a circus hoop windscreen.

The custom built engine is as usual in full view, sporting plenty of sparkling chrome parts, and long flowing exhaust pipes. The, what we call beach-buggy-type, cab is lined with very luxurious looking tufted upholstery, and has two very small stools for seats. More scroll work is used to decorate the chassis, which is supported by drag slicks at the back and wide wheels at the front. Lots more chrome parts and a few comic transfers complete the model.

There's not much we can comment on about this model, apart from the fact that it was a joy to build (no trouble with badly fitting parts) and that we can't wait to receive the next one, which we're sure will be along soon.

*Continued on page 87*

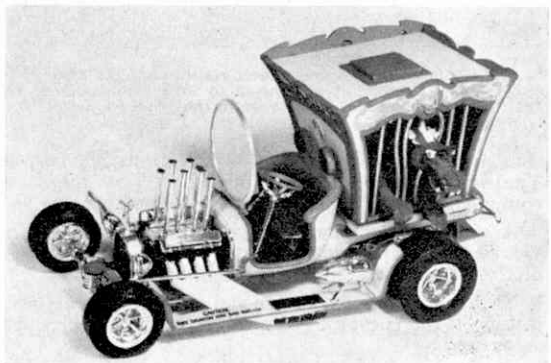

**As promised in last month's 'WORKBENCH' reproduced here are a selection of photographs showing our . . .**

## **'RADIO 4-2'**

# **FROG 1100 Conversion to RADIO CONTROL**

THIS RADIO controlled car, described and illustrated in last month's free supplement took only a couple of hours to convert from a simple 1/12th scale motorised kit into a fully operational radio controlled model.

The existing body-shell, chassis, steering unit, wheels, electrical motor and gearbox were used in

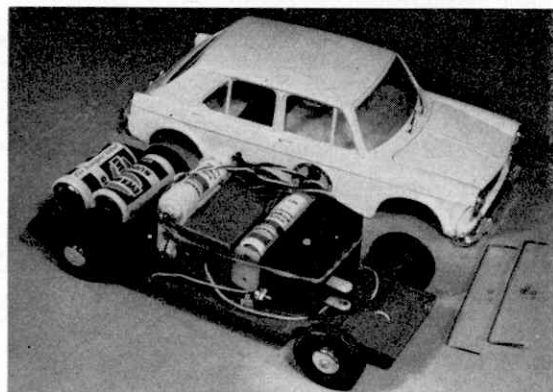

Shown above with the body-shell removed. The two piano wire parts at the right were used to secure the body to the chassis. This is more clearly seen in the heading photograph.

standard form, without any modifications whatsoever. The accompanying photographs show how the radio equipment and batteries fit neatly under the body.

A piece of card prevents the equipment from being viewed through the windows and finishes off the model nicely, as can be seen in the heading photograph.

The total cost of the model was just over £13, making it the cheapest radio controlled model available at present!

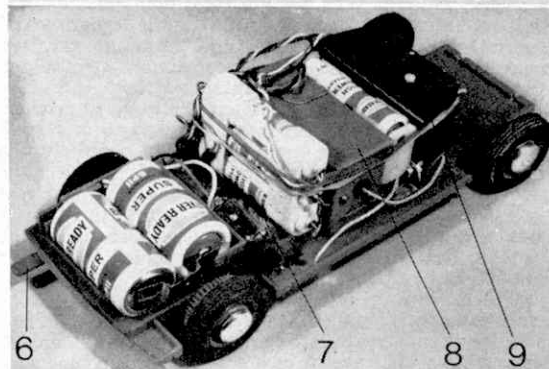
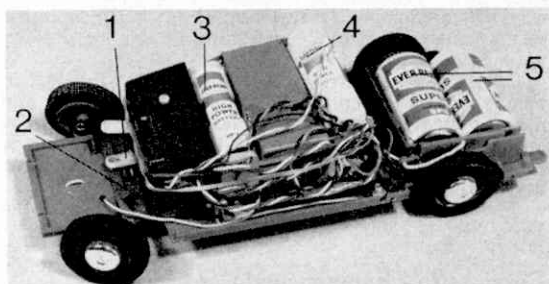

Upper photograph: The servo arm 1 is fitted with a small nut and bolt, the latter passing through a small hole drilled into the steering lie-bar 2. The servo operating batteries 3, and receiver batteries 4 are either side of the receiver. The propulsion batteries 5 are fitted into the container which is part of the original kit.

Lower photograph: Projecting at the rear of the chassis is the propulsion motor on/off switch 6. The original reduction gearbox 7 is part of the original kit. The receiver (Mainstream) is located in the centre of the chassis. The Mainstream servo 9 is bolted to the chassis using a pair of small Meccano brackets.

# Add more to your **MECCANO**<sup>®</sup> more parts – more fun

Add-on a power unit-get things moving Super Sets to add your scope to Meccano

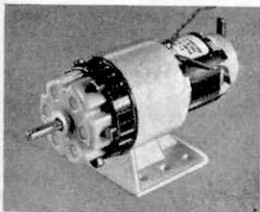

**Power Drive Motor with 6-Ratio Gearbox** Copper-graphite brushes have a life of more than 1,000 hours. Works from a 3-12 volts D.C. power supply. **£2.15.11.**

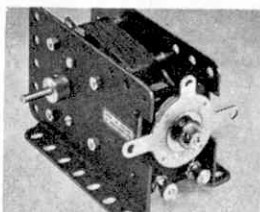

**E15R Electric Motor** 12/15 volt motor with built-in reversing switch. Will operate through transformer or give adequate power when run from suitable batteries. **£3.9.11.**

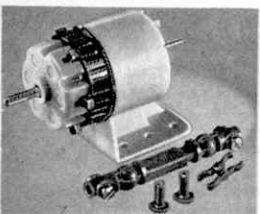

**Power Drive 6-Ratio Gearbox with universal coupling** Transmission ratios 3:1, 6:1, 12:1, 16:1, 32:1, 60:1. Can be coupled to any motor or other driving source that uses a 5/32" diameter spindle (Standard Meccano Rod size). **£1.16.11.**



**Power Drive 4 1/2 v. D.C. Reversible Motor** This motor will run on Direct Current of 4 1/2 volts, which may be supplied by a battery such as types 1289, F40 or equivalent. It has a stop, forward and reverse lever. **£1.6.11**

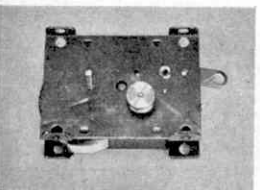

**Magic Motor** Non-reversible clockwork motor, specially intended for driving many of the smaller Meccano models. **11s.6d.**

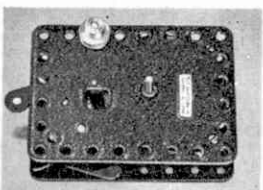

**No. 1 Clockwork Motor** Fitted with reversing mechanism – suitable for driving many of the larger models. **£1.12.6.**

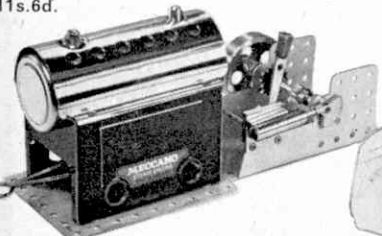

**STEAM ENGINE** Super-efficient power to drive off gears, chains and pulleys. Works on water heated by methylated spirits burner. Operating reversing lever. **£3.15.0.**

**MECHANISMS SET**  
All the parts and instructions needed for making clutches, differentials, disc brakes, free wheels and all sorts of useful mechanisms. **£2.5.0.**

**ELEKTRIKIT**  
Parts for building all sorts of electrically-operated equipment . . . simple Electric Bell, real Morse Telegraph, Compass, Transformer, Electric Crane Grab and many electric motors. **£4.15.0.**

**GEARS SET**  
Contains lots of parts – plus an engineering manual – for making dozens of drives and gears . . . twin-drives, intermittent drives, spur gearings, etc. **£1.8.6.**

**SUPER TOOL SET**  
Contains automatic nut holder to speed up construction; a long screwdriver and a flexible drive spanner to reach right into the most awkward corners. **18s.11d.**

An extra hand-for more model building fun

**CONVERSION SETS**  
To convert one main Set into the next larger e.g. Set 3 + Conversion Set 3A = Set 4. It's as easy as that! Simply enlarge the scope of Meccano by adding a Conversion Set that helps build bigger, better models. 7 Conversion Sets—from 12/11.

Plastic  
MOTORISED!  
**MECCANO**  
SITE ENGINEERING SET

THE WORLD'S GREATEST

CONSTRUCTIONAL TOY

KINDLY MENTION "MECCANO MAGAZINE" WHEN REPLYING TO ADVERTISEMENTS



# CLASSIFIED ADVERTISEMENTS

**PRIVATE:** Minimum 18 words 6s. and 4d per word for each subsequent word.

**TRADE:** Minimum 18 words 12s. and 8d. per word for each subsequent word.

Box numbers count as six words when costing the advertisement. When addresses are included these are chargeable at the same rate (4d. or 8d.) per word as the remainder of the advertisement. Copy and box number replies should be sent to the Classified Advertisement Department, MECCANO Magazine, 13-35 Bridge Street, Hemel Hempstead, Herts. Latest copy date for insertion in the March issue, Jan. 8th.

## BOOKS

**Top Wargamers** read Miniature Warfare, the world's leading monthly magazine for wargamers and wargaming. For a trial copy send 4s. (65c) and a 12" x 9" s.a.e. (U.K. 5d., Overseas 31.R.C.s) to—Miniature Warfare, Dept. M.M., 61 Benares Road, Plumstead, London S.E.18, England. Trade enquiries welcome, wholesale or retail. S-D

**Magazine Binding.** Reasonable charges. S.A.E. details—N. B. Wilkie, 51 Hamilton Drive, Elgin, Morayshire. YZAB

## STAMPS

**Commonwealth Foreign Discount Approvals.** Free gift to new applicants.—A. Renner, Dept. MM., 57 Warwick Road, Beaconsfield, Bucks. U-Z

**Six Beautiful Bird Stamps** free to applicants for our Commonwealth and foreign discount approvals.—Kingdom Stamps, 16 Dromeeon Avenue, Beaumont, Dublin 9. YZA

## TRADE

**£40 (Minimum) Offered** for M.M.'s 1916-1939, complete. Portions welcomed, also volumes. —Lambert, 60 Salhouse Road, Rackheath, Norwich. Z-D

## FOR SALE

**No. 9 Outfit** built up over a period of four years with electric and clockwork motors, also Elektrikit and many extra gears. Offers.—Johnson, 32 Rushmore Avenue, Northampton. Z

**Obsolete Parts,** perfect replicas. P/N 156, Pointer \$(Australian) 0-75 each, Airmail \$1.00. P/N 119, Channel Segments \$8.00 per set of eight, airmail \$9.50.—W. R. Inglis 219 Blackburn Road, Sth., Blackburn, 3130, Victoria, Australia. ZA

**Special Clearance Offer** of 35 mm. Railway colour slides. "Old and New Locomotives," set of 20 slides, 15s.; "Swiss Railway and Cable Railways," set of 12, 9s.; "German Railways," set of 9, 7s. 6d.; "Loco Coaches," set of 9, 6s. Add 1s. per set, post and packing. —Harringay Photographic Supplies, 435 Green Lanes, London N.4. V-A

**Air Gunners,** send 3s. 6d. for my new mail order catalogue. Huge selection of tested air rifles and air pistols from £9 to nearly £90, for example original, Feinwerkbau, Anschutz, Webley, Weihrauch, B.S.A., Haenel, Walther, etc. Plus pages and pages of illustrations, facts and figures of interest to all. Also details of a wide range of specially imported and exclusive accessories, like German cleaning gear (from 2s. 6d.), gun covers and cases, magazines, books, international targets, highest quality ammo (.177", .22" and .25"), space age lubricants (for faster action and peak power) and so on. Send 3s. 6d. now and get the facts straight from Britain's only air weapon specialists.—D. R. Hughes (Mail Order 2), Post Office Box 155, South Croydon, Surrey. Z

## WANTED

**Pre-war Meccano Magazines** Wanted, complete years only.—Advertiser, Prior Field, Corbridge, Northumberland. Z

**Pre-War model trains** sought by Lowke, Marklin, Bing, etc. O or larger also tinplate toys.—10 Church Hill, Patcham Village, Brighton, 53940. T/C

**Coins Wanted.** Mixed. World. School-boy collections. £1 per 100. No zinc or aluminium. —Williams, 41 Garnetts, Takeley, Essex. P-A

**Model Cars** of all sorts wanted. Good prices (or exchange) for early die-cast models, tinplate toys, obsolete kits, etc., which will be incorporated in a permanent display.—Dr. Gibson, The Green, Anstey, Leicester. U-F

**Meccano Magazines** up to 1926 inclusive. Meccano high voltage motors. All three types. Meccano accumulators 2, 4 and 6 volt. All letters answered.—W. R. Inglis, 219 Blackburn Road, South Blackburn, 3130, Victoria, Australia. ZA

## GREAT BRITAIN

2/6, 5/- & 10/- FREE

This packet of stamps is given absolutely FREE to all genuine applicants for my superior used British Colonial Approvals enclosing 4d. in stamps for postage. Overseas Applications invited.

**D. L. ARCHER (M),**

2 LITCHFIELD WAY, BROXBORNE, HERTS.

## CHEMICALS AND APPARATUS

You can now buy Chemicals and Apparatus —Test-tubes, Beakers, Flasks, Filter Paper —everything you need to build up your own HOME LABORATORY!  
You save money by ordering Direct from Suppliers. Send 6d. stamps NOW for Latest List and Order Form. (Overseas enquiries welcomed)  
**P.X. TECHNICAL SUPPLIES**  
53, Eldon Street, Sheffield, 1

## RADIO

S.A.E. brings free brochure. An introduction to R/C control and details of the world's best single channel tone guidance system. Over 5,000 in current use throughout the world, quantity produced and fully guaranteed for best range and quality at only £13. Complete 6 and 10 channel Multi Reed outfits with or without Servo Packs, from £35½. Digital two, three, four and five channel Proportional equipment from £84. Good selection of second-hand Radio always in stock.

## VISIT THE LARGEST MODEL STOCKISTS IN THE COUNTRY

★ STAFFED BY EXPERTS ★ PART EXCHANGE ★ H.P. FACILITIES ★ MAIL ORDER INCLUDING OVERSEAS ★  
ORDERS UNDER £3 POSTAGE & PACKING 2/-  
All Shops open until 8.30 p.m. Friday.  
Leicester, Weston and Wimbledon closed Monday. Isleworth open each weekday.  
WE SERVICE ALL RADIO EQUIPMENT WE SELL

## KITS, ENGINES, ACC.

We stock all current Kits, Engines and Accessories. We hold large stocks of Balsa and plywood as well as engine spares, radio parts and kits of parts. We always have bargain lines, as well as a good selection of second-hand Boats, Aircraft, Marine and Air-cooled Engines.

560 0473

## RADIO CONTROL SUPPLIES

LEIC. 21935

581 LONDON ROAD, ISLEWORTH, MIDDX.

52a LONDON ROAD, LEICESTER

154 MERTON ROAD, WIMBLEDON 540 4887

1, THE CENTRE, WESTON-SUPER-MARE WESTON 6600

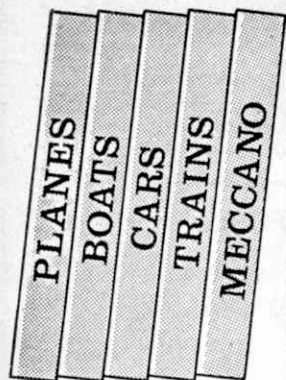

# MODEL SHOP DIRECTORY

**M** denotes Meccano accessory and spare parts specialists

## GUILDFORD

Tel: 61331

THE GUILDFORD  
DOLL'S HOSPITAL LTD.,  
13 SWAN LANE,  
GUILDFORD.

**M**

## HEMEL HEMPSTEAD

Tel: 53691

**TAYLOR & McKENNA**

203, MARLOWES

**M**

## KENT

Tel: Erith 32339

DERRETT (TOYS) LTD.,  
52/54 ERITH HIGH STREET,  
ERITH, KENT.

Aircraft, Boats, Fibreglass Hulls, Tri-ang Hornby, Lima H.O., H. & M. Units, Scalextric, Airfix, Riko, Pacra, Plastic kits, Minitanks, Marquetry. Prompt Mail Order Service.

## KENT

Tel: Dartford 24155

MODERN MODELS LTD.,  
49/51 LOWFIELD STREET,  
DARTFORD, KENT.

For all your modelling requirements. Radio/Control, Aircraft, Boats, Cars, Railways. All leading makes from The Shop with the Stock. Prompt mail order service.

## LEEDS, I

Tel: 25739

BRADFORD MODEL  
RAILWAY CENTRE,  
23 ALBION PLACE,  
(Off Briggate).

The North's Leading Model Railway stockists in OO and N gauges. Branches at Cloth Hall Street, Huddersfield and Frizinghall, Bradford.

## LEICESTER

Tel: Leicester 21935

RADIO CONTROL  
SUPPLIES LTD.,  
52 LONDON ROAD,  
Mail Order Specialists.  
Closed Monday.

Open until 8.30 p.m. Friday.  
The Showroom of the Midlands with full R/C service facilities.

## LIVERPOOL

Tel: 709-7562

LUCAS'S (HOBBIES) LTD.,  
7 TARLETON STREET,  
LIVERPOOL I.

HOBBIES or everything the model maker requires. Aeroplanes, Cars, Chemistry Sets, Railways, Meccano Building Kits, Instructional Toys, also a selection of Games, Dolls and Soft Toys.

## BATH

Tel: 60444

CYRIL HOWE'S  
CHEAP STREET,  
BATH, SOMERSET.

The Model Shop of the West for all your modelling requirements. Aircraft, Boats, Engines, Radio Control. Expert advice available. M.A.P., Meccano Sets, spares, etc.

## BEACONSFIELD

Tel: 4092

C. G. MARSHALL,  
MAXWELL ROAD,  
BEACONSFIELD, BUCKS.

**M**

## BIRMINGHAM

Highbury 3237

KINGS HEATH MODELS  
5 York Road, Birmingham 14.

Everything for the modeller: Boats, Cars, Planes, Railways, Kits, etc. Meccano sets and reasonable stocks of spares.

## BLACKPOOL

Tel: Blackpool 24061

BATESON'S SPORTS  
DEPOT LTD.,  
56 ABINGTON STREET,  
BLACKPOOL.

Complete Stocks all through the Year.

## BOURNEMOUTH

Tel: Bournemouth 23248

BRUCES TOYS LTD.,  
87-89 OLD CHRISTCHURCH ROAD,  
BOURNEMOUTH.

We stock a wide range of Meccano Toys and outfits with adequate spares for expanding outfits.

## BRISTOL

Tel: 38534

M. H. B. DAWSON,  
96 WHITELADIES ROAD,  
BRISTOL 8.

**M**

## BRISTOL

Tel: 557527

MAX WILLIAMS  
LAWRENCE HILL,  
BRISTOL 5.

Meccano Model Railways, Peco, Wills, Slot Racing, Hobby Kits, Dinky, Corgi and all spares.

## CARLISLE

Tel: Carlisle 23142

PALACE CYCLE STORES,  
122 BOTCHERGATE,  
CARLISLE.

Meccano Stockists for Airfix, Dinky, Match-box etc.

## CHATHAM

Tel: Medway 45215

W. PAINE & CO. LTD.,  
168 HIGH STREET,  
CHATHAM.

**M**

## CREWE

Tel: Crewe 55643

EVELYN WILSON,  
86-88 MARKET STREET,  
CREWE, CHESHIRE.

Meccano Sets — Accessories and Spares — Hornby Tri-ang Train Sets — Accessories and Spares — Frog Kits.

## DORCHESTER

Tel 300

BRAGG'S SPORTS DEPOT,  
15 HIGH WEST STREET,  
DORCHESTER, DORSET.

Stockists for whole range of Meccano, Trains, etc., also Travel Goods, Toys and Games.

## ELGIN

Tel: Elgin 2569

GEO. A. SMITH,  
10 BATCHEN STREET,  
ELGIN.

All your Meccano and Dinky requirements are in stock always.

**LONDON**

Tel: HOL 6285

BEATTIES OF LONDON,  
112 & 112A HIGH HOLBORN,  
LONDON W.C.1.

**LONDON**

Tel: 01-529 1250

"LEISURE TIME"  
4 STATION ROAD, CHINGFORD,  
LONDON E.4.  
Aircraft, Electric Cars, Boats, Railways and  
Accessories, Plastic Kits, Modelling Activities.  
Secondhand models section.  
All models bought, sold and exchanged.

**SCARBOROUGH**

Tel: Scarborough 3223

"WALKERS,"  
15 ST. THOMAS STREET  
SCARBOROUGH, YORKS.  
(Mail orders welcomed.)

**LONDON**

Tel: Lee Green 2637

LEWISHAM MODEL  
CENTRE  
45 LEE HIGH ROAD, LEWISHAM, S.E.13  
Everything for the Modeller, Aircraft,  
Boats, Radio Control, Railways, Cars.  
Spares and Repairs our speciality.  
Mail Order a pleasure.

**LONDON**

Tel: 01-445 6531

MICHAEL'S MODELS  
646-8 HIGH ROAD,  
N. FINCHLEY, N.12.  
Comprehensive range of kits and modelling  
accessories. Stockists of Fischer Technik, the  
new action construction toy.  
Mail Order a Pleasure.  
Closed all day Monday. Easy parking.

**STAFFORD**

Tel: 3 420

JOHN W. BAGNALL LTD.,  
18 SALTER STREET,  
STAFFORD.

**LONDON**

Tel: Regent 1846

JEREMY,  
16 PRINCES ARCADE,  
PICCADILLY, LONDON, S.W.1.

**MANCHESTER**

Tel: Blackfriars 3972

THE MODEL SHOP  
7-13 BOOTLE STREET,  
OFF DEANSGATE,  
MANCHESTER 2.  
THE NORTH'S LEADING MODEL, HOBBY  
AND TOY SHOP. MECCANO SETS AND  
SPARE PARTS A SPECIALITY.

**STOCKTON-ON-TEES**

Tel: 67616

LESLIE BROWN,  
Super Toy and Model Store  
95 HIGH STREET,  
STOCKTON-ON-TEES.

**LONDON**

Tel: CHE 4887

**RADIO CONTROL  
SUPPLIES**

154 MERTON ROAD,  
WIMBLEDON S.W.19  
Closed all day Monday.  
Open until 8.30 p.m. Friday.  
Largest R/C stockists in the country.

**NEW ZEALAND**

BUNKERS LTD.,  
P.O. BOX 58,  
HASTINGS.

(Mail orders from all countries welcomed.)

**SURREY**

Tel: Camberley 5926

JOYLAND,  
56 HIGH STREET,  
FRIMLEY, SURREY.  
Full range of Meccano and Spares  
Tri-ang-Hornby Railways, Scalextric, Lego  
Largest selection of toys and games in the area.

**LONDON**

Tel: ISLeworth 0743

**RADIO CONTROL  
SUPPLIES LTD.,**

581 LONDON RD., ISLEWORTH,  
MIDDX. Mail Order Specialists  
Open each weekday and until  
8.30 p.m. Fridays.  
Largest R/C stockists in the country.  
Own R/C service centre.

**READING**

Tel: Reading 51558

**READING MODEL SUPPLIES**

5 Chatham St. Car Park, Oxford Road,  
READING, BERKSHIRE.

BERKSHIRE'S MODEL CENTRE  
You can drive right to us.

**WATFORD**

Tel: Watford 44222

CLEMENTS,  
THE PARADE, WATFORD.

Always a comprehensive range of Meccano  
Sets, Accessories and Dinky Toys.

**LONDON**

Tel: Mill Hill 2877

H. A. BLUNT & SONS LTD.,  
133 THE BROADWAY,  
MILL HILL, LONDON N.W.7.

**ST. ALBANS**

Tel: 59234

BOLD & BURROWS LTD.,  
19-23 CHEQUERS STREET,  
ST. ALBANS, HERTS.

Meccano Sets and Spares.

**WESTON-SUPER-MARE**

Tel: Weston 6600

RADIO CONTROL SUPPLIES LTD.,  
1 THE CENTRE,  
WESTON-SUPER-MARE, SOMERSET.  
Open until 8.30 p.m. Friday.  
Largest R/C stockists in the country.  
Own R/C service centre.

**MODEL SHOP OWNERS****Use Our Model Shop  
Directory**

Write to Meccano Advertisement Offices:

MODEL AND ALLIED PUBLICATIONS LTD,  
13/35 Bridge Street, Hemel Hempstead, Herts.

**ADD TO THAT GIFT**

MECCANO		PHILLIPS	
1a - - 12/11	2a - - 17/11	1051 - 57/6	1052 - 54/0
3a - - 29/11	4a - - 35/6	1004 - 89/6	1005 - 105/0
5a - - 28/6			
7a - - 119/6	6a - - 47/6		
Gears Set - - - - - 28/6		<b>MAMOD</b>	
Mech. Set - - - - - 45/0		Polishing Machine - - - 9/6	
Elektrikit - - - - - 95/0		Grinding Machine - - - 9/6	
4½ volt Motor - - - - 26/11		Power Hammer - - - 10/3	
Gear Box and Motor - - 55/11		Power Press - - - 10/3	
Gear Box and Coupling - 36/11		Lineshaft - - - 19/3	
Steam Engine - - - - 75/0		Open Wagon - - - 37/9	
		Lumber Wagon - - - 37/9	

Full range of spares stocked for Meccano, Phillips and Mamod.  
S.A.E. for Lists. P. & P. extra on all items under £5.

**JOHN W. BAGNALL LTD.**  
SALTER STREET, STAFFORD Tel. 3420



the next best thing to the real thing...

# Authenticics by Humbrol!



Years of research has developed these colours which are as near to the real thing as the real thing itself. They provide an ultra-thin film which doesn't show brush marks or clog fine detail.

There's a comprehensive range of colours for railways—aircraft—military uniforms and equipment—ships and racing cars which you can buy in single tinslets or in kits of six\*.

\*Recommended retail price in U.K. Tinlet 1/9, Kits 9/9.

LOOK FOR  
THE LOCKER



Get the real thing from...

# HUMBROL

HUMBROL · HULL · YORKSHIRE

MODEL CLUB  
QUERY  
COUPON

Printed in Great Britain by ELECTRICAL PRESS LTD., Maidenhead, Berks., for the Proprietors, MODEL & ALLIED PUBLICATIONS LTD., 13/35 Bridge Street, Hemel Hempstead, Herts. Published by the ARGUS PRESS LTD., 12/18 Paul Street, London, E.C.2, to whom all trade enquiries should be addressed.  
Registered for transmission by Magazine Post to Canada.

MM PHOTO  
COMP COUPON  
FEBRUARY 1970



Win the  
**"Battle of Britain"**  
 with  
**DINKY**  
**TOYS®**

© Spitfire Productions Ltd., 1963

Two dog-fighting warplanes  
direct from the epic film

**SPITFIRE Mk II**

Britain's greatest ally in the battle with the enemy, this super replica of our most famous fighter plane has real working features. Retractable undercarriage and battery-driven propeller meet the "Scramble" command instantly. And with realistic transparent canopy and tough, moulded exhaust pipes and propeller. Battery not supplied.

Model No. 719

**JUNKERS Ju 87B**

This is the screaming Stuka dive-bomber that's going to give your Spitfire some really fierce competition. Champion of the Luftwaffe, this warplane carried a devastating 1102-lb bomb. Our bomb fires caps for extra realism - drop it right on target every time with the special bomb release button. True-to-life features include moulded cockpit, canopy and propeller. Caps not supplied

Model No. 721

Get the new Dinky Book of Cars, only 3d. from your local toy shop



leaders go for  
**DINKY**  
**TOYS**

the tough, action-packed models





# MAP The Finest Range of Model Technical Books in the World! The Finest Range of Model Technical Books in the World!

**155 MAN POWERED FLIGHT**  
**Man-Powered Flight**  
In this, the first book primarily aimed at the student of man powered flight, Dr. K. Sherwin of the University of Liverpool analyses the problems of design structure and operation, adding his own theories for production of a practical "pedal scooter". Over 120 specially selected illustrations collected by Aeromodeller staff convey a pictorial history of progress and combined with more than 90 text diagrams, form a scientific reference work of great value to all students of aviation.  
176 pages, 8 1/2 x 5 1/2 in. (International A5 size) with 2lbs straw board covers, bound in Balacron with gold blocking on spine. (£7.00) £1.75

**156 CHALLENGE IN THE AIR**  
The story of the Air Training Corps from its tenacious beginnings after the 1914-18 war, when the idea of a youth organisation with an aeronautical flavour formed in the minds of two young ex-servicemen, to its present position as the main source of recruits for the Royal Air Force. The story unfolds via the formation of the Air League's Air Defence Cadet Corps, through the difficult days of World War 2 - during which the Air Training Corps was formed - to the present day.  
164 pages on antique wove paper and white glossy plates size 5 1/2 x 8 1/2, being 120 pages of text and thirty-five pages of illustrations. Bound in Linson, with gold foil blocked title on spine and colour dust cover. (£7.00) £1.75

**14 BOAT MODELLING**  
**BOAT MODELLING**  
A comprehensive book for the not-so-expert modeller covering every aspect of model boat work from construction through to sailing. Author Vic Smeed provides a wealth of practical assistance. Chapters include: Tools and materials, hard chine hulls, round bilge hulls, superstructure fittings, finishing; I.C. engines, electric motors, hydroplanes and special models; operations; radio control.  
8 1/2 x 5 1/2 in. 96 pages. Text illustrated with 223 line drawings and 8 pages of art plates showing 50 photographs of models. (£1.25) 40p

**122 SHIPS OF LONDON RIVER**  
**SHIPS of London River**  
A captioned selection of craft to be seen from the Port of London down to the sea, from fussy tugs to stately merchant vessels and liners.  
4 3/4 x 7 1/4 in. 60 pages. Landscape. Two-colour card cover. Fifty photo-illustrations. (\$1.00) 25p

**10 SEVENTEENTH CENTURY RIGGING**  
**SEVENTEENTH CENTURY RIGGING**  
The true atmosphere of early sailing craft can only be captured by authentic rigging detail. A really comprehensive study of the subject that could hardly be bettered, and written with special consideration of the needs of modellers. A book of wide interest for all who love the sea and who need historical reference for their modelling.  
8 1/2 x 5 1/2 in. 146 pages. Two-colour drawn on card cover. 9 photo-illustrations. 250 figures comprised in 23 fold-out drawings. (\$3.00) 75p

**152 CONTAINER SHIPS**  
**CONTAINER SHIPS**  
A broad picture of the history of container ships, showing the different types of ships and the ports they serve. Covers most of the routes of the world, with a selection of principal ports, and is representative of container ships of the world both deep sea routes and short sea routes. Profusely illustrated with line, wash and photographic reproductions. Some 50 container company badges and emblems also illustrated.  
9 1/2 x 7 1/2 in., 127 pages. Bound blue balacron, two colour photo dust cover, gold-blocked title on spine. 154 photo illustrations, 64 line drawings, 50 container company emblems. (19c) £3

**149 AEROMODELLER ANNUAL 1970-71**  
**Aero Model**  
Features on Airfoil Research, the Wankel Motor, Electric RTP models capable of fast flight and aerobatics. Analysis of airfoils for gliders. Over 40 of the top designs of the year - contest winners, unorthodox new structures, free flight, control-line and radio controlled plus humble chuck gliders. A pot pourri of the very best, produced to satisfy all tastes and wonderful value as a reference book.  
128 pages size 8 1/2 x 5 1/2 ins. Coloured cover (photo) bound boards. (\$2.50) 60p

**2 AIRCRAFT IN MINIATURE**  
**AIRCRAFT IN MINIATURE**  
The art of science of static scale model aircraft construction demands only the modest tools and the simplest of materials so that no high initial expenditure is required to make a start.  
8 1/2 x 5 1/2 in. 130 pages, including 50,000 words of text, 244 detailed drawings, over 30 models and art plates. Fully bound with gold-blocked title on spine. (£2.50c) 62 1/2p

**19 SECRETS OF SHIPS IN BOTTLES**  
**SHIPS IN BOTTLES**  
Of all the fascinating models, perhaps the ship-in-a-bottle is the most intriguing. Such models, made by old seadogs, have for generations puzzled the land-lubber; now you have the chance to share the secret.  
7 1/4 x 4 1/4 in., 72 pages. Profusely illustrated with line drawings, photo plates (65 figs.). Bound in drawn on card cover. (£1.25) 30p

**11 MODELLING THE REVENGE**  
**MODELLING THE REVENGE**  
Detailed description of an Elizabethan ship-of-war and how to model it. Part I: The Hull, covers first stages, rigging and painting. Part II: Deals with Rigging, including masts and spars, standing rigging, running rigging, sails, finishing touches. Guns, deck details and many other details well illustrated. Working drawings by the author also available.  
7 1/4 x 4 1/4 in. 85 pages. Two-colour card cover. 83 line drawings, one half-tone picture. (\$1.00) 25p

**147 MODERN SHIPS**  
**MODERN SHIPS**  
A broad cross section of the world's shipping during the past 15 years. Could be called 'Modern Ships, their Voyages and Cargoes, together with the Ports they visit and the Passengers they carry'. Chapters on Oil Tankers, Bulk Carriers, Container Ships, Vehicle Ferries, Passenger Liners, Cargo Liners, Crew Accommodation, Coastal Ships, Tugs, Cargo Handling, Trawlers, 12-Passenger Cargo Liners and Miscellaneous ships together with appendices on organisations and bodies closely connected with ships.  
9 1/2 x 7 1/2 in. Bound in balacron on high quality gloss paper. 220 pages. Two-colour photo-dust cover. (\$11.95) £5

**103 SHIPS OF THE MODERN ROYAL NAVY**  
**SHIPS OF THE MODERN ROYAL NAVY**  
Nearly 100 photographs, the majority full-page of ships and details of ships comprising 20 pages of plans - Ton Triumph, Battle, Salisbury, Eagle, Bulwark, Tide, Forth, Range, County, Manxman, Daring, Bar, Mull, Agile, Ham, Ford, Agile and Tiger - with descriptive text, plus several tabular pages listing equipment and detailing all other ships, to provide a comprehensive survey of the vessels in current use.  
128 pages, size 9 1/2 x 7 1/2 in., art paper and first class reproduction throughout. In Linson and board covers, gold block spine, colourful dust jacket. (£7.00) £1.75

**AEROMODELLING 8 FLYING SCALE MODELS**  
**FLYING SCALE MODELS**  
R. G. Moulton  
All types of scale flying models are described in turn - glider, free flight and control line. Jets, diesel, rubber or ducted fan types. Much useful information is given on achieving highly realistic finished and detailed parts and there is a useful set of tables listing camouflagage and insignia from 1914 up to date. Very large number of illustrations, including photographs diagrams and scale plans.  
8 1/2 x 5 1/2 in. Hard bound. Over 300 diagrams, sketches, photo-illustrations, 40,000 words. Lists of Aircraft Manufacturers, useful Organisations and References. Includes several useful aircraft scale drawings. (\$2.50) 62 1/2p

**3 AEROMODELLER POCKET DATA BOOK**  
**AEROMODELLER POCKET DATA BOOK**  
Simply packed with clear sketches and useful tables to help modellers in every branch of aero modelling.  
7 1/2 x 4 1/2 in. 64 pages. With 61 pages of detailed explanatory sketches and text, based on Flying Models Reference Handbook. (\$1.25) 30p

**143 RADIO CONTROL MODEL BOATS**  
**RADIO CONTROL MODEL BOATS**  
A really up-to-the-minute treatise on radio control as applied to power boats. Written by two of the best-known experts in boating, Philip Connolly and Vic Smeed, this book answers many questions which have not previously been covered in book form. Chapters include a brief history, fundamental principles, types of equipment including proportional, design of displacement and planing hulls, i.e. engines, electric power, electric power control, accumulators and dry cells, actuators and servomechanisms, installation and wiring, transistors and transistor circuits. Comprehensive to the beginner and helpful to the expert, no boat enthusiast can afford to be without a copy.  
128 pages, 8 1/2 x 5 1/2 in., 55 photo-illustrations, 123 line drawings. Full colour, hard cover. (\$3.75) 90p

**9 THE ANATOMY OF NELSON'S SHIPS**  
**THE ANATOMY OF NELSON'S SHIPS**  
C. Nepean Longridge  
A fantastic tour-de-force embracing the most complete information ever for the benefit of the ship modeller intent on building a wooden ship of Nelson's time. Its very completeness makes it also of special interest to the naval historian. Drawings, illustrations, plans are all superb.  
9 1/2 x 7 in. Gold blocked title on red panel on spine and on front. 183 drawings, 12 fold-out plans, 76 plates. Decorative dust cover. (\$12.50) £3.15

**12 POWER MODEL BOATS**  
**POWER MODEL BOATS**  
V. E. Smeed  
Guides the enthusiast happily through the pitfalls of his progress. Within its covers will be found a wealth of information on all forms of hull construction, materials in common use, suitable tools; the different types of motor and their best employment; simple approach to radio control; boat fittings, couplings shafts and propellers, super structure, painting and finishing; unorthodox models, including submarines; and a valuable selection of 'Do's and Don'ts'.  
8 1/2 x 5 1/2 in. 128 pages. 250 photo-illustrations and line drawings. Bound in hard boards, linson covered with gold foil title on spine. (\$3.50) 90p

**142 BRITISH AIRCRAFT CARRIERS**  
**BRITISH AIRCRAFT CARRIERS**  
This book covers the complete history of British aircraft carriers from the first conversions of 1914 to the last of the ships currently in service. Twenty chapters cover each individual or class of carrier, with 16 drawings and 67 half- or full-page photographs, plus detailed notes of the career of every vessel.  
104 art paper pages, size 9 1/2 x 7 1/2 in., cloth bound in hard covers with gold blocked title and attractive dust jacket. (£7.00) £1.75

**7 CONTROL LINE MANUAL**  
**CONTROL LINE**  
R. G. Moulton  
Main chapter headings: Why Control Line?; Basic U-Control; Basic Monoline; Basic Flight Control; Learning to Fly; Aerobatics; Speed; Team Racing; Combat; Carrier; Cargo and Endurance; Scale Models; Jet. The Engine in Control Line; Towards the Indestructible; Looking after the Lines; Variations on the Theme. Plus appendixes.  
8 1/2 x 5 1/2 in. Hard bound. Chapter headings by cartoonist Roland, over 300 diagrams, sketches, photo-illustrations. 74,000 words. (\$3.00) 90p

**1 ALL ABOUT MODEL AIRCRAFT**  
**All About Model Aircraft**  
by Peter Chinn  
A detailed book for the beginner... the author is world famous for his clear descriptions and in 21 comprehensive chapters with a wealth of photo-illustrations, covers this wide subject.  
All about rubber- or power-driven models - free flight, control line; including building instructions for a trailer, model aero engines and fuels. Completely revised 1968 and with 30 new illustrations, revisions. Over 50,000 sold of earlier editions.  
160 pages, 8 1/2 x 5 1/2 in., profusely illustrated throughout. Full colour hard cover. (\$3.00) 75p

**157 NEW GLASSFIBRE BOOK**  
**THE NEW GLASSFIBRE BOOK**  
It is now over ten years since the first title on this subject *Glassfibre for Amateurs* was produced and whilst most of the techniques and materials are as originally described a great deal of additional experience has been gained so that a new book treating the subject differently has become desirable. In these pages, which are laid out for very easy reference, the author deals with 'GRP', glassfibre materials, resins, fillers, pigments and painting agents; moulds, tools and equipment, basic techniques, castings, moulded shapes; roof lights and panels, GRP tanks, boats, cars; modelling and domestic applications, garden pots, repairs, trouble shooting; designs in GRP. Appendixes.  
8 1/2 x 5 1/2 in. (A5). 126 pages. Profusely illustrated in line drawings. Drawn on card cover. (\$3.00) 75p

**58 MULTI CHANNEL RADIO CONTROL**  
**Multi Channel Radio Control**  
This book has been introduced to help the beginner over his problems. Here the beginner will find explained in simple terms the working of multi-channel equipment.  
8 1/2 x 5 1/2 in. 96 pages. Full-colour photo dust cover. Numerous line and photo illustrations on high-quality gloss paper. (\$2.00) 52 1/2p

**107 RADIO CONTROL MANUAL 2**  
**RADIO CONTROL MANUAL 2**  
Ron Warring discusses control surface design. Peter Chinn on R/C engine developments. Don Careless provides expert advice on the art of multi-model racing. Don Baxter on the operation of R/C water planes. Peter Waters, passes on the secrets for successes in R/C Goodyear racing. 17 scale drawings of some of the world's leading model designs.  
8 1/2 x 5 1/2 in. 128 pages. 83 photo-illustrations, 49 diagrams, 17 model plans. Bound in hard boards with full-colour cover photo. (\$2.75) 67 1/2p

**130 MODELLING TUDOR SHIPS**  
**MODELLING TUDOR SHIPS**  
Another valuable book on modelling ships of 'romantic' times from the author of *Period Ship Modelling*. Eleven chapters cover: The Sixteenth Century; the Ship; the Hull - keel and frames; the Hull - planking fitting bulkheads, decks, bulwarks; Painting and Decorating; Detail fittings; Masts, spars, tops; Standing Rigging; Running Rigging; Sails; Finishing off.  
7 1/2 x 4 1/4 in., 76 pages. Two-colour card cover. 45 line drawings. (\$1.00) 25p

**4 MODEL AERO ENGINE ENCYCLOPAEDIA**  
**ENGINE ENCYCLOPAEDIA**  
All the known world's engines are detailed in tabular summary with principal dimensions and advised propellers. Three extensive chapters deal with initial operation of a first engine, whether it be coil ignition, diesel or glowplug. Advanced data on fuels, horsepower, speed controls, silencers and tuning of racing engines. Fully updated and revised.  
8 1/2 x 5 1/2 in. 208 pages. Full bound in plastic cloth, with three-colour dust jacket, over 300 sketches, photos, data tables. (\$3.00) 75p

**122 SIMPLE CARDBOARD MODELS**  
**SIMPLE CARDBOARD MODELS**  
This magnificently illustrated book deals with working models of Rollers, Road Engines, Ships, Cars, Tracklaying Vehicles, Rail and Tramway models and other working models including models of RMS Scillonian and the Ruston Bucyrus Excavator.  
120 pages, square backed, drawn on two-colour cover. 75 photo-illustrations. 77 including working plans. (\$3.00) 75p

**75 GARRETT'S OF LEISTON**  
**GARRETT'S OF LEISTON**  
'Garretts of Leiston', the family business which has been running for nearly two hundred years, and which has built every type of steam road engine. Chapters include: 1. The Family, 2. The Works and Firm, 3. Leiston Products up to the Great Exhibition 1851. 4. Between Two Exhibitions, 1842-1862. 5. Thousands of Portables and a few Tractor Engines, 1862-1894. 6. The Years of Adventure, 1895-1919. 7. The Post-War Years, 1919-1930. 8. A Knight to the Rescue. 9. Garrett's Place in the Scene.  
Size 9 1/2 x 6 1/2 in. Case-bound. 319 pages. 155 photographs, drawings and reproductions of old prints. (£8.50) £2.10

**59 SINGLE CHANNEL RADIO CONTROL**  
**Single Channel Radio Control**  
By R. H. Warring  
A 'must' for beginners, this book covers in simple language all that the newcomer should know on single channel equipment - the route by which most enthusiasts find their way to radio control. Chapters cover general definitions, simple receivers and transmitters and then go on to cover actuators, escapements and servos. Suitable aircraft types and their power plants plus consideration of possible manoeuvres. Control systems for single channel - mainly rudder, but also engine control, and brief thoughts on more elaborate methods. Then boat and vehicle systems. Installation of equipment, operation, testing, fault-finding and trouble shooting are covered. Finally, valuable tables deal with available equipment, receivers, transmitters, servos, actuators, escapements.  
7 1/2 x 4 1/2 in. 80 pages with 50 diagrams, plus 12 art pages of photo-pictures. Numerous tables. Drawn on card photo cover in two colours. (\$1.25c) 30p

**18 PERIOD SHIP MODELLING**  
**PERIOD SHIP MODELLING**  
R.K. Balfour  
7 1/2 x 4 1/2 in. 80 pages. Two-colour card cover. Illustrated line drawings. (\$1.00) 25p

**20 HISTORY OF BRITISH DINKY TOYS 1934-64**  
**HISTORY OF BRITISH DINKY TOYS 1934-64**  
A book devoted to the products of one toy factory. It contains not only a short history of the original company which produced Dinky Toys, but also a year-to-year description of the cars issued, with a fine selection of photographs devoted mainly to earlier and less commonly seen examples, and a very valuable series of tables listing all Dinky Toys, 1934-64 in numerical order with a special numbering system which is designed to smooth the way for collectors.  
8 1/2 x 5 1/2 in. 152 pages. Cloth bound, gold-blocked spine. Two-colour dust cover, 76 photo-illustrations, numerous tables. (\$3.00) 75p

**80 MODERN MANUAL FOR DRIVERS OF STEAM ROAD VEHICLES**  
**STEAM ROAD VEHICLES**  
It embodies all that could be gleaned from surviving professionals on the subject of driving, maintaining, servicing and operating all classes of steam road vehicles. It is no technical tome but a completely practical work written from the novice's point of view by a non-engineering author, who has nevertheless had the benefit of the advice of a number of real experts.  
8 1/2 x 5 1/2 in. 133 pages, plus eight pages of plates, well illustrated with sketches and drawings. Bound in Balacron with title blocked on spine, plus halftone photo dust cover in black and yellow. (£1.05) 84.25c

**108 STEAM UP!**  
**Steam Up!**  
Anthony Beaumont provides a new selection of traction engine and wagon pictures - printed lithographically to do justice to the fine photographs. There are 50 page pictures, plus cover illustration.  
4 1/2 x 7 1/4 in. Two-colour drawn-on card cover, index, introductory notes. (\$1.25) 30p

**117 SOLARBO BOOK OF BALSA MODELS**  
**SOLARBO BOOK OF BALSA MODELS**  
Making a Building Board, Boxes and Cabinets, Racks a Bird-house; Solid Balsa Carved Figures; Space Frame Models; Balza Bridges; Carved solid models - aircraft, cars, ships; Carving Propellers; Chuck and Catapult Gliders; Whip Control Models; Boomerangs; Kites, Helicopters, Heli-Kite; Simple Ship Models; water line ship models; power models; Prop-Hydro; Round Bilge Hulls; Submarine; Kon Tiki Raft; Catamaran; Scale Car and Roadside Models; Trackside Models; Airport Buildings; Architectural Models; Military Models; Puppets and Puppet Theatres; Airspeed Indicator/Beam Balance; Slide Rule; Micrometer; Calipers; Lule; Two-stroke engine; Text and Photos.  
10 1/2 x 5 1/2 in. 112 pages. (\$3.00) 75p

**158 MODEL CAR RACING BY RADIO CONTROL**  
**Model Car Racing by Radio Control**  
George Sippos  
The first book entirely devoted to the subject by American expert George Sippos, suitably edited for British market and availability of parts in this country. Covers the construction and operation of one-eighth scale Grand Prix and G.T. cars in detail with chapters on engine, power train, suspension system, chassis-frame, bodies and their mounting, accessories and equipment. Chassis tuning, pre-race preparation, diving and trouble shooting covered. Installation of radio control equipment detailed, and brief particulars of r/c needs. Appendix gives suggested Racing Rules. Drawings and description for building a car, also particulars of a number of construction kits available.  
8 1/2 x 5 1/2 ins. (A5), 87 pages. Profusely illustrated in photo and line. Full colour card cover drawn on. (\$3) 75p

**23 MODEL CARS ENCYCLOPAEDIA**  
**Model Cars Encyclopedia**  
Brings together a wealth of information for the benefit of expert and beginner alike, conveniently arranged in A-Z form. It is an attempt to assemble in one place quite a lot of information about electric model car racing.  
7 1/2 x 4 1/2 in. 151 pages. 104 illustrations. 45,000 words. (\$1.00) 25p

**116 MODEL CARS SLOT MOTORS**  
**Model Cars Slot Motors**  
Most useful up-to-date review (Autumn 1968) of available slot motors for electric car racing, plus articles on basic hot-up, re-winding, gears.  
7 1/2 x 4 1/2 in. 64 pages. Coloured cover. Illustrated. (50c) 12 1/2p

**79 TRACTION ENGINE PICTURES**  
**TRACTION ENGINE PICTURES**  
A Beaumont  
Sixty traction engine pictures of all shapes and sizes.  
4 1/2 x 7 1/4 in. Landscape. 64 pages. Two-colour drawn on card cover. 60 photo-illustrations. (\$1.25) 30p

**148 GALLERY OF OLD TIMERS**  
**A Gallery of Old Timers**  
by Anthony Beaumont  
A new Anthony Beaumont miscellany of traction engines, steam ploughing, fire engines, fair grounds, rides, steam rollers, wagons, all hitherto unpublished or historic.  
51 pictures. 64 pages. 7 1/2 x 4 1/2 in. (\$1.25) 30p

**113 FAIR ORGANS**  
**FAIR ORGANS**  
A. Beaumont  
This book contains many illustrations of beautifully restored Fair Organs of bygone years. Fascinating for the younger reader whilst arousing pleasant memories in those who remember the era of Fair Organs.  
4 1/2 x 7 1/4 in. Two-colour drawn-on card cover, 56 pages. 50 photo-illustrations index, introductory notes. (\$1.00) 25p

**74 THE BRITISH TRAM**  
**THE BRITISH TRAM**  
by Frank E. Wilson  
'Travel at Midday - Twopence all the Way' was a pre-war slogan of the trams, and author Frank Wilson takes the reader from the very beginning with horse-drawn trams, through their heyday when Austin Sevens were alleged to get stuck in the rails and carried on to the depot, until their eventual eclipse in modern times. Chapters cover History, General Features, Lines, the Car itself, how it worked, and the passing of an era.  
7 1/2 x 4 1/2 in. 87 pages. Two-colour drawn on card cover. 59 mainly photo-illustrations (many rare). (\$1.25) 35p

**21 SIMPLE ELECTRIC CAR RACING**  
**SIMPLE ELECTRIC CAR RACING**  
Anyone coming new to the hobby will find in its pages the answers to questions likely to arise in building cars and tracks from scratch; a great portion of its content will also be invaluable to those who buy commercial cars and track.  
7 1/2 x 4 1/2 in. 104 pages. 65 photos. 37 line drawings. Drawn on card cover with attractive dust jacket. (\$3) 75p

**145 MOTOR TUNING**  
**MOTOR TUNING**  
The complete story of tuning of 'can' motors in twenty-three sections by Dan Glimme, as published in three supplements in *Model Cars*. These three booklets in attractive gold lettered binder comprising over 80 pages of profusely illustrated material. 37 1/2 x 7 1/2 in., in stout card binder. Special post free price. (\$1.50)

**PLOUGHING BY STEAM**  
**PLOUGHING BY STEAM**  
This magnificent book by expert enthusiast authors Colin Tyler and John Haining may well become the definitive work on the subject. It comprises some 98,000 words, 250 illustrations and drawings, and covers steam ploughing from every point of view, including historical use of equipment, engines, implements and models. Some eight years research has gone into its preparation with the help and assistance of museums, libraries, record office companies and private individuals. Old illustrations and documents have been largely drawn upon, so that not only does it provide an authentic history of its time, but skillful use of material has produced a manner of presentation that is particularly pleasing. The authors in addition to their interest in full-sized steam ploughing have built and operated scale model steam ploughing equipment which has been shown on television and at exhibitions.  
360 pages, 9 1/2 x 6 in. Four colour dust cover. 250 illustrations. (\$12.00) £3

**76 TRACTION ENGINES ON PARADE**  
**TRACTION ENGINES ON PARADE**  
A. Beaumont  
A captioned selection of showman's road locomotives, tractors, traction engines and steam motor tractors, wagons, portable engines, ploughing engines and rollers.  
4 1/2 x 7 1/4 in. Landscape. 58 pages. Two-colour drawn on cover. 58 photo-illustrations. (\$1.00) 25p

**78 PLOUGHING ENGINES AT WORK**  
**PLOUGHING ENGINES AT WORK**  
Barry J. Finch  
A fine photo collection of ploughing engines and their ancillary equipment at work.  
7 1/2 x 7 1/4 in. Landscape. 58 pages. Two-colour drawn on card cover. 58 photo-illustrations. (\$1.00) 25p

**159 SCALE PLASTIC KITS OF THE WORLD**  
**Scale Plastic Kits of the World 1971**  
A survey prepared by specialists in the International Plastic Modellers Society. Covers manufacturers' identity codes, kits for aircraft, locomotives, ships, cars, A.F.V., space, historic figures, with manufacturers' addresses. 7 1/2 x 4 1/2 in. 64 pages of small type tabular matter, trade (75c) 17 1/2p advertisements.

**53 RING CIRCUITS IN THE HOME**  
**RING CIRCUITS IN THE HOME**  
The wider use of electrical appliances demands that the home handyman extends the existing wiring of his home or workshop in a safe and simple way. Ring Circuits in the Home provides the answer to all the questions likely to arise in planning, fitting, testing and checking the new installation.  
7 1/2 x 4 1/2 in. 94 pages. 54 illustrations. Drawn on card cover. (\$1.50) 37 1/2p

**159 SCALE PLASTIC KITS OF THE WORLD**  
**Scale Plastic Kits of the World 1971**  
A survey prepared by specialists in the International Plastic Modellers Society. Covers manufacturers' identity codes, kits for aircraft, locomotives, ships, cars, A.F.V., space, historic figures, with manufacturers' addresses. 7 1/2 x 4 1/2 in. 64 pages of small type tabular matter, trade (75c) 17 1/2p advertisements.



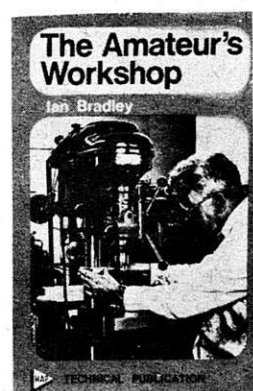

153 THE AMATEUR'S WORKSHOP. It is now over twenty years since the author in collaboration with the late Dr. N. Hallows produced a book of similar title and objects...



106 THE NOVICES' WORKSHOP. This work is designed to assist and instruct the newcomer to the craft in the all-important matters of planning and layout of the home workshop...

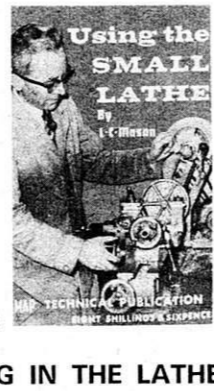

32 USING THE SMALL LATHE. A book of guidance and data for modeller and engineer. Typical chapter headings: A First Lathe; Chucking; Driving and Turning...



67 MODEL LOCOMOTIVE VALVE GEARS. Martin Evans Gears covered include single-eccentric slip eccentric, Stephenson Link, Gooch and Allan Straight...

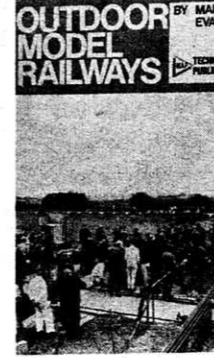

144 OUTDOOR MODEL RAILWAYS. A new book by Martin Evans, first to deal with outdoor steam powered model railways in gauges up to 15 in.

200 SIMPLE MODEL LOCOMOTIVE BUILDING. One of LBS's best-known 3 1/4 in. gauge locomotives. "Tich" is the subject of the "words and music" which serve as an introduction...

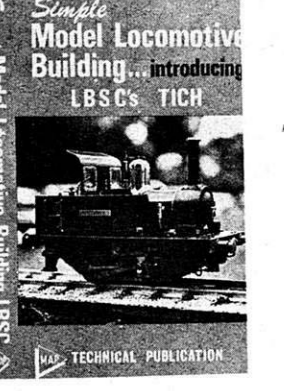

83 x 53 in. (A5) 265 pages. Text illustrated with 445 line drawings and photo captions. Bound blue Balacron, gold blocked title on spine, two colour photo dust cover. £2.50

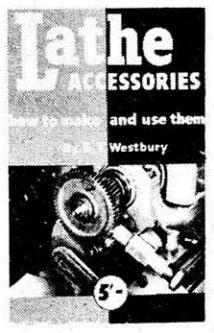

45 LATHE ACCESSORIES. How to make and use a wide variety of useful accessories.

WORKSHOP LATHES TOOLS. Duplex Sharpened materials, appliances, metalworking tools...



25 SHARPENING SMALL TOOLS. Sharpened materials, appliances, metalworking tools...



24 HOW TO WORK SHEET METAL. Metal working practice straight from the bench. Practical chapters embrace: Equipment; Metalworking; Following and Blocking; Planing...

37 MILLING IN THE LATHE. In this well-illustrated text of use of milling cutters of various types is explained; milling without special appliances by use of ordinary lathe movements...

42 ELECTRO-PLATING FOR THE AMATEUR. The subject is adequately covered and deals with equipment needed for home working, current supply, plating tank, preparation of baths...



131 WALSCHAERTS' VALVE GEAR. Deals extensively with the subject covering application, design and layout, expansion link, return crank mechanism and design, combination lever, operation of valve gear.

146 MYFORD ML 10 LATHE MANUAL. By Ian Bradly For all ML lathe owners and operators, and indeed for all small lathe users, this is an essential tool!



141 LBSC'S SHOP, SHED & ROAD... This famous book of L.B.S.C. first appeared in 1929 and established him in the forefront of miniature steam locomotive experts for all time.

141 LBSC'S SHOP, SHED & ROAD... This famous book of L.B.S.C. first appeared in 1929 and established him in the forefront of miniature steam locomotive experts for all time.

RAILWAYS · LOCOMOTIVE BUILDING. This famous book of L.B.S.C. first appeared in 1929 and established him in the forefront of miniature steam locomotive experts for all time.

63 PACIFIC STEAM. The 4-6-2 locomotive hailed many of the famous express such as 'The Coronation Scot', 'The Flying Scotsman' and 'The Golden Arrow'.

63 PACIFIC STEAM. The 4-6-2 locomotive hailed many of the famous express such as 'The Coronation Scot', 'The Flying Scotsman' and 'The Golden Arrow'.

140 MODEL LOCOMOTIVE BOILERS. A completely new work in which author Martin Evans covers the whole subject of model locomotive boilers in the light of modern practice.

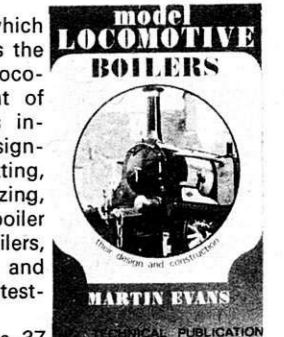

43 DROUNTRYWORK FOR THE AMATEUR. B. T. Aspin. A really exhaustive book on mould and pattern making, and pouring metals to produce castings for model making or other purposes.

50 BEARING DESIGN & FITTING. Duplex (Ian Bradley & Norman Hallows). A valuable small book on plain, roller and ball bearings, with details of materials used, lubrication, mounting, protection, aligning, thrust bearings, re-aligning, needle roller bearings, applications, to machine tools, design of bearings, ideal dimensions.

50 BEARING DESIGN & FITTING. Duplex (Ian Bradley & Norman Hallows). A valuable small book on plain, roller and ball bearings, with details of materials used, lubrication, mounting, protection, aligning, thrust bearings, re-aligning, needle roller bearings, applications, to machine tools, design of bearings, ideal dimensions.

50 BEARING DESIGN & FITTING. Duplex (Ian Bradley & Norman Hallows). A valuable small book on plain, roller and ball bearings, with details of materials used, lubrication, mounting, protection, aligning, thrust bearings, re-aligning, needle roller bearings, applications, to machine tools, design of bearings, ideal dimensions.

47 HARDENING & TEMPERING ENGINEERS' TOOLS. A valuable workshop book for expert and beginner alike, contains colour scale diagram, chapters on principles, annealing, hardening, tempering, special tools, forging light tools, case-hardening, tungsten carbide and hard alloy, gas and electric furnaces.

123 MICROMETERS, SLIDE GAUGES & CALIPERS. Covering simple and registering calipers; slide gauges; vernier scales and their use; micrometer reading; micrometer construction; micrometer; examples of modern micrometers; use of measuring instruments.

123 MICROMETERS, SLIDE GAUGES & CALIPERS. Covering simple and registering calipers; slide gauges; vernier scales and their use; micrometer reading; micrometer construction; micrometer; examples of modern micrometers; use of measuring instruments.

123 MICROMETERS, SLIDE GAUGES & CALIPERS. Covering simple and registering calipers; slide gauges; vernier scales and their use; micrometer reading; micrometer construction; micrometer; examples of modern micrometers; use of measuring instruments.

34 MECHANICAL FACTS MADE EASY. P. Marshall and R. B. Wray. Claimed 1001 facts, this is a handbook of simple mechanical knowledge for everyone interested in model or general engineering.

105 METAL TURNING LATHES. This work embraces the latest practice and covers the evolution of the lathe, details a number of models on the market, and goes on to discuss elements of lathe design.

105 METAL TURNING LATHES. This work embraces the latest practice and covers the evolution of the lathe, details a number of models on the market, and goes on to discuss elements of lathe design.

105 METAL TURNING LATHES. This work embraces the latest practice and covers the evolution of the lathe, details a number of models on the market, and goes on to discuss elements of lathe design.

44 GEAR WHEELS AND GEAR CUTTING. Principles and methods of production of toothed gearing. Proportions and form of teeth of gear wheels covered; there are chapters on pin wheels, bevel gears, worm gears, other pages cover helical gears, spiral gears, chain gearing, epicyclic gears and special forms.

72 PAINTING AND LINING MODELS. Duplex. An expert gives valuable information on this tricky subject, plus a wealth of tabulated information of interest even to the expert, deals with methods of cutting threads, equipment, covering the various forms in general use, taps and dies, both by hand and in the lathe.

72 PAINTING AND LINING MODELS. Duplex. An expert gives valuable information on this tricky subject, plus a wealth of tabulated information of interest even to the expert, deals with methods of cutting threads, equipment, covering the various forms in general use, taps and dies, both by hand and in the lathe.

72 PAINTING AND LINING MODELS. Duplex. An expert gives valuable information on this tricky subject, plus a wealth of tabulated information of interest even to the expert, deals with methods of cutting threads, equipment, covering the various forms in general use, taps and dies, both by hand and in the lathe.

29 BUILDING A STEAM ENGINE FROM CASTINGS. Building a Stuart, 10V engine, from casting to testing, with details of machining bedplate castings, trunk column and cylinder, steam chest covers and fly-wheel, crankshaft, cross-head and bearings, piston and connecting rod, eccentric rod and valve gear, valve timing.

39 THREE DIMENSIONAL PROJECTION DRAWING. A basic knowledge of three dimensional projection drawing is of special assistance to the model maker and model engineer. It helps to clarify shapes and dimensions of normal working drawings and prevents time wasting or costly errors of interpretation.

39 THREE DIMENSIONAL PROJECTION DRAWING. A basic knowledge of three dimensional projection drawing is of special assistance to the model maker and model engineer. It helps to clarify shapes and dimensions of normal working drawings and prevents time wasting or costly errors of interpretation.

39 THREE DIMENSIONAL PROJECTION DRAWING. A basic knowledge of three dimensional projection drawing is of special assistance to the model maker and model engineer. It helps to clarify shapes and dimensions of normal working drawings and prevents time wasting or costly errors of interpretation.

129 MIN. BUILDING CONSTRUCTION. 9 x 6 in. 160 pages. 83 line drawings, 26 half-tone illustrations. Drawn on two colour card cover. £2.50

129 MIN. BUILDING CONSTRUCTION. 9 x 6 in. 160 pages. 83 line drawings, 26 half-tone illustrations. Drawn on two colour card cover. £2.50

129 MIN. BUILDING CONSTRUCTION. 9 x 6 in. 160 pages. 83 line drawings, 26 half-tone illustrations. Drawn on two colour card cover. £2.50

129 MIN. BUILDING CONSTRUCTION. 9 x 6 in. 160 pages. 83 line drawings, 26 half-tone illustrations. Drawn on two colour card cover. £2.50

129 MIN. BUILDING CONSTRUCTION. 9 x 6 in. 160 pages. 83 line drawings, 26 half-tone illustrations. Drawn on two colour card cover. £2.50

129 MIN. BUILDING CONSTRUCTION. 9 x 6 in. 160 pages. 83 line drawings, 26 half-tone illustrations. Drawn on two colour card cover. £2.50

129 MIN. BUILDING CONSTRUCTION. 9 x 6 in. 160 pages. 83 line drawings, 26 half-tone illustrations. Drawn on two colour card cover. £2.50

129 MIN. BUILDING CONSTRUCTION. 9 x 6 in. 160 pages. 83 line drawings, 26 half-tone illustrations. Drawn on two colour card cover. £2.50

129 MIN. BUILDING CONSTRUCTION. 9 x 6 in. 160 pages. 83 line drawings, 26 half-tone illustrations. Drawn on two colour card cover. £2.50

129 MIN. BUILDING CONSTRUCTION. 9 x 6 in. 160 pages. 83 line drawings, 26 half-tone illustrations. Drawn on two colour card cover. £2.50

129 MIN. BUILDING CONSTRUCTION. 9 x 6 in. 160 pages. 83 line drawings, 26 half-tone illustrations. Drawn on two colour card cover. £2.50

129 MIN. BUILDING CONSTRUCTION. 9 x 6 in. 160 pages. 83 line drawings, 26 half-tone illustrations. Drawn on two colour card cover. £2.50

129 MIN. BUILDING CONSTRUCTION. 9 x 6 in. 160 pages. 83 line drawings, 26 half-tone illustrations. Drawn on two colour card cover. £2.50

129 MIN. BUILDING CONSTRUCTION. 9 x 6 in. 160 pages. 83 line drawings, 26 half-tone illustrations. Drawn on two colour card cover. £2.50

129 MIN. BUILDING CONSTRUCTION. 9 x 6 in. 160 pages. 83 line drawings, 26 half-tone illustrations. Drawn on two colour card cover. £2.50

129 MIN. BUILDING CONSTRUCTION. 9 x 6 in. 160 pages. 83 line drawings, 26 half-tone illustrations. Drawn on two colour card cover. £2.50

129 MIN. BUILDING CONSTRUCTION. 9 x 6 in. 160 pages. 83 line drawings, 26 half-tone illustrations. Drawn on two colour card cover. £2.50

129 MIN. BUILDING CONSTRUCTION. 9 x 6 in. 160 pages. 83 line drawings, 26 half-tone illustrations. Drawn on two colour card cover. £2.50

129 MIN. BUILDING CONSTRUCTION. 9 x 6 in. 160 pages. 83 line drawings, 26 half-tone illustrations. Drawn on two colour card cover. £2.50

129 MIN. BUILDING CONSTRUCTION. 9 x 6 in. 160 pages. 83 line drawings, 26 half-tone illustrations. Drawn on two colour card cover. £2.50

129 MIN. BUILDING CONSTRUCTION. 9 x 6 in. 160 pages. 83 line drawings, 26 half-tone illustrations. Drawn on two colour card cover. £2.50

129 MIN. BUILDING CONSTRUCTION. 9 x 6 in. 160 pages. 83 line drawings, 26 half-tone illustrations. Drawn on two colour card cover. £2.50

129 MIN. BUILDING CONSTRUCTION. 9 x 6 in. 160 pages. 83 line drawings, 26 half-tone illustrations. Drawn on two colour card cover. £2.50

129 MIN. BUILDING CONSTRUCTION. 9 x 6 in. 160 pages. 83 line drawings, 26 half-tone illustrations. Drawn on two colour card cover. £2.50

129 MIN. BUILDING CONSTRUCTION. 9 x 6 in. 160 pages. 83 line drawings, 26 half-tone illustrations. Drawn on two colour card cover. £2.50

129 MIN. BUILDING CONSTRUCTION. 9 x 6 in. 160 pages. 83 line drawings, 26 half-tone illustrations. Drawn on two colour card cover. £2.50

129 MIN. BUILDING CONSTRUCTION. 9 x 6 in. 160 pages. 83 line drawings, 26 half-tone illustrations. Drawn on two colour card cover. £2.50

129 MIN. BUILDING CONSTRUCTION. 9 x 6 in. 160 pages. 83 line drawings, 26 half-tone illustrations. Drawn on two colour card cover. £2.50

129 MIN. BUILDING CONSTRUCTION. 9 x 6 in. 160 pages. 83 line drawings, 26 half-tone illustrations. Drawn on two colour card cover. £2.50

129 MIN. BUILDING CONSTRUCTION. 9 x 6 in. 160 pages. 83 line drawings, 26 half-tone illustrations. Drawn on two colour card cover. £2.50

129 MIN. BUILDING CONSTRUCTION. 9 x 6 in. 160 pages. 83 line drawings, 26 half-tone illustrations. Drawn on two colour card cover. £2.50

129 MIN. BUILDING CONSTRUCTION. 9 x 6 in. 160 pages. 83 line drawings, 26 half-tone illustrations. Drawn on two colour card cover. £2.50

129 MIN. BUILDING CONSTRUCTION. 9 x 6 in. 160 pages. 83 line drawings, 26 half-tone illustrations. Drawn on two colour card cover. £2.50

129 MIN. BUILDING CONSTRUCTION. 9 x 6 in. 160 pages. 83 line drawings, 26 half-tone illustrations. Drawn on two colour card cover. £2.50

129 MIN. BUILDING CONSTRUCTION. 9 x 6 in. 160 pages. 83 line drawings, 26 half-tone illustrations. Drawn on two colour card cover. £2.50

129 MIN. BUILDING CONSTRUCTION. 9 x 6 in. 160 pages. 83 line drawings, 26 half-tone illustrations. Drawn on two colour card cover. £2.50

129 MIN. BUILDING CONSTRUCTION. 9 x 6 in. 160 pages. 83 line drawings, 26 half-tone illustrations. Drawn on two colour card cover. £2.50

£2.35 inclusive of postage is the same for all our magazines except MODEL ENGINEER which has TWO issues a month and costs twice as much - that is £4.70 a year.

MAP The Finest Range of Model Technical Books in the World!

For Office Use

Printed by Graphic Art Services (Brighton) Ltd., Burgess Hill, Sussex.