

# MECCANO<sup>®</sup> Magazine

MAY 1972

15p

U.S.A. & CANADA  
SEVENTY-FIVE CENTS



SUBMARINE CABLES • POTATOES  
ASBESTOS • SMITHFIELD MARKET



HOBBY MAGAZINE

**FOR THE INVENTIVE AND THE INQUISITIVE**



HAVE FUN WITH  
THESE HIGH FLYING  
CATAPULT GLIDERS  
FULL-SIZE PLANS  
ETC. INSIDE!

# Skill, patience and Humbrol

Or should it be Humbrol, patience and skill? Either way, these are the three most important qualities for successful modelling.

Skill and patience – well, most serious modellers have them. Humbrol is the quality they all need. Used by modellers the world over, Humbrol enamels (matt or gloss, lead free and non-toxic) are the best value for money on the modelling market . . . only 7p for 15ml. Research has established that craftsmen prefer model paint in tins which keep the paint in good condition, are unbreakable and much safer than any other type of container—this is why Humbrol is packed in handy sized tinlets.

You'll find the colour you're looking for in the Humbrol range. Ask for Humbrol by name . . . available from all leading Model and Toy Shops.



All Humbrol quality enamels are available in separate tinlets or in tinlet palettes—attractive and convenient interlocking plastic trays with space for brushes and accessories.



**Balsa cement 66** for sticking balsa models. Med. tube 6p  
**White PVA 55** for sticking wooden models. Med. tube 10p.

**Polystyrene cement 77** for sticking plastic models. Med. tube 6p.

All Britfix tubes have a specially designed shoulder cap with internal spigot preventing blockage of nozzle and giving immediate flow when cap is removed.

Humbrol will be pleased to send you—*FREE*—colour cards and leaflets giving you full details of the extensive range of enamels and other Humbrol quality products for the modeller. Write today to Mr. H. Stewart, Modelling Division, Humbrol Limited, Marfleet, Hull.

**HUMBROL**  
HULL · YORKSHIRE

# MECCANO® Magazine

MAY 1972 VOLUME 57 NUMBER 5

Meccano Magazine, founded 1916

Editorial Director

**D. J. LAIDLAW-DICKSON**

Managing Editor

**V. E. SMEED**

Consulting Editor for MECCANO

**J. D. McHARD**

Advertisement Manager

**ROLAND SUTTON**



**HOBBY MAGAZINE**



## FRONT COVER

Stephen Archibald's catapult gliders are capable of fast and exciting flights despite their cheapness and simplicity.

## NEXT MONTH

Airships and Dolphins are two subjects among next month's interesting (and dare we say educational?) articles. A full-size plan will appear as usual.

Advertisements and Subscription Offices: Model & Allied Publications Ltd., 13-35 Bridge Street, Hemel Hempstead, Hertfordshire. Tel.: Hemel Hempstead 2501-2-3.

Second class postage rates paid at New York, N.Y. Registered at the G.P.O. for transmission by Canadian Post. American enquiries regarding news stand sales should be sent to MECCANO MAGAZINE, Eastern News Distributors Inc., 155 West 15th Street, New York, N.Y. 10011, U.S.A. U.S.A. and Canada direct subscription rates \$6 including index.

This periodical is sold subject to the following conditions: that it shall not, without the written consent of the publishers, be lent, re-sold, hired-out or otherwise disposed of by way of Trade at a price in excess of the recommended maximum price and that it shall not be lent, re-sold, hired-out or otherwise disposed of in a mutilated condition, or in any unauthorised cover by way of Trade; or affixed to or as part of any publication of advertising, literary or pictorial matter whatsoever.

Correspondence anticipating a reply must be accompanied by stamped and self addressed envelope or international reply coupon. While every care is taken no responsibility can be accepted for unsolicited manuscripts, photographs or art work, etc.

The Advertisement Manager reserves the right to refuse or suspend advertisements without giving any reason. Every care is taken to avoid mistakes, but the publishers cannot be held liable in any way for clerical and printing errors or omissions. Receipt of "copy" for publication implies acceptance of these conditions by the advertiser. Whilst every care is taken to exclude advertisements from doubtful sources, no responsibility can be accepted by the publishers for the bona fides of advertisers.

**Publishers of Aeromodeller, Model Boats, Model Cars, Model Engineer, Radio Control Models, Model Railways, Scale Models, Woodworker, Military Modelling.**

## CONTENTS

<b>ON THE EDITOR'S DESK</b>	217
<i>News and views</i>	
<b>SUBMARINE CABLES</b>	218
<i>A remarkably extensive network</i>	
<b>NUREMBERG TOY FAIR</b>	222
<i>New goods from the biggest fair</i>	
<b>OUT OF THIS WORLD</b>	224
<i>New Dinky Toys</i>	
<b>AMONG THE MODEL BUILDERS</b>	226
<i>More ingenuity from readers</i>	
<b>POTATOES YIELD TO ROBOT DIGGERS</b>	228
<i>More in a spud than meets the eye!</i>	
<b>ASBESTOS</b>	230
<i>A surprisingly ubiquitous material</i>	
<b>CATAPULT AIRCRAFT</b>	233
<i>Three simple super flyers</i>	
<b>TRY DEVELOPING YOUR OWN</b>	236
<i>One of the thrills of photography</i>	
<b>CENTRIFUGAL MOTOR-CYCLIST</b>	238
<i>A real fun model</i>	
<b>NATIONAL PARKS ON STAMPS</b>	241
<i>Good for Geography, too</i>	
<b>BRIDGES, PART 4</b>	242
<i>Design and construction thereof</i>	
<b>TO MARKET</b>	244
<i>Smithfield, meat market supreme</i>	
<b>BIG BEN</b>	246
<i>Familiar sight and sound</i>	
<b>AIR NEWS</b>	247
<i>What's going on in aviation</i>	
<b>BLACK SWAN</b>	250
<i>One of Australia's attractive fauna</i>	
<b>MECCANO PARTS AND HOW TO USE THEM</b>	257
<i>Part 5</i>	
<b>MECCANO COMPETITION</b>	253
<i>£4,000 in prizes!</i>	

**MODEL & ALLIED PUBLICATIONS LTD.  
13-35 BRIDGE STREET, HEMEL HEMPSTEAD, HERTFORDSHIRE**

NEW MECCANO NEWS

# **NOW** *you can build* **a real** *Working clock!*

Introducing Meccano Clock Kits.  
Each ingenious Kit gives you all the parts you need to make a real, working pendulum wall clock—and you **don't** have to be a genius to build one. Everything comes ready to assemble, and you even make the movement—no motor is needed.  
Kit 1—illustrated—is available now, and Kit 2, which makes a bigger clock with a chime, will follow later.

You'll have the time of your life with Meccano Clock kits.

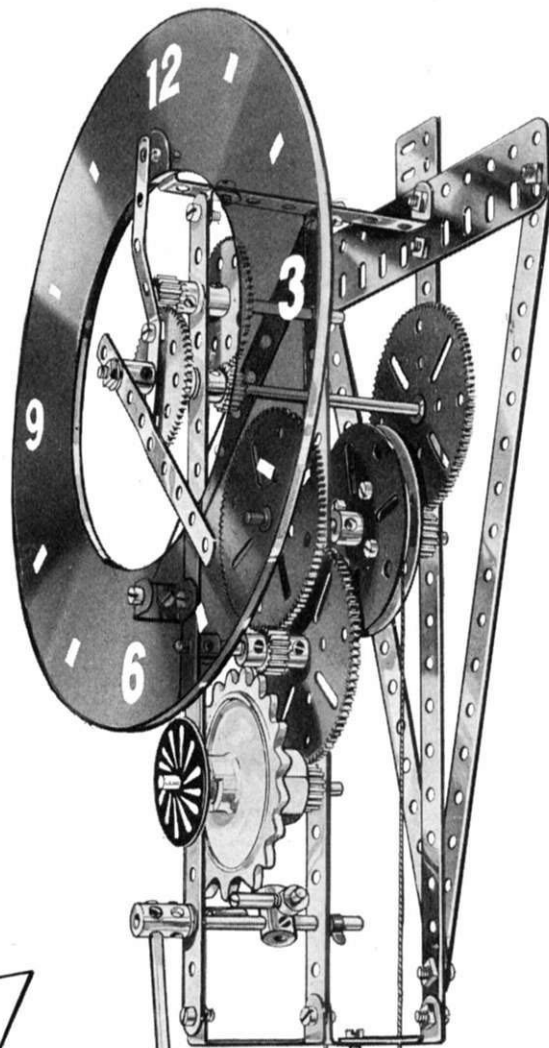

**Easy-to-follow**  
**working**  
**drawings**



# **NEW** **MECCANO** **CLOCK KITS**

KINDLY MENTION "MECCANO MAGAZINE" WHEN REPLYING TO ADVERTISEMENTS

# "617 SQUADRON?"

## NOW WHO WERE THEY?"

It's a question that strikes coldly on the ear of the middle-aged. A generation has grown up which may not even have seen the film 'The Dam Busters', much less remember the real-life chapter of a famous RAF squadron. For a generation to whom Agincourt, Trafalgar, and Waterloo are more familiar names than Möhne, Eder, and Sorpe, we briefly retell the splendid story.

To compress into a few sentences years of work and frustration, Barnes Wallis invented the bouncing bomb. The task he set himself was to devise a bomb that would skip over protective anti-torpedo nets, make contact with the upper side of the dam structure, and then slide down the face of the dam to explode exactly thirty feet below the surface. In the end (as we now know), he succeeded perfectly. But he relied on others to deliver the bomb—or rather the many bombs to be aimed at a whole series of dams in the Ruhr Valley.

Early in 1943, Guy Gibson was chosen to form and lead the Lancaster squadron that was to be

identified as 617. Not yet twenty-five, he was already a Wing Commander with exceptional experience over Germany, and a DSO and DFC. He had to learn—and train his men in—utterly new bombing techniques. The squadron's Lancaster bombers had to fly at a speed of 240 miles an hour and an exact 60 feet above the surface of the water, releasing the bomb 450 yards from the dam. No altimeter was exact enough to ensure accuracy of height, so two spotlights were fitted beneath the Lancasters at such an angle that their beams would converge at exactly 60 feet. So the aircraft on this most precise of all raids would actually be carrying lights!

The month of May was chosen for the raid, because the dams would then be holding back the maximum tonnage of water. The first aircraft

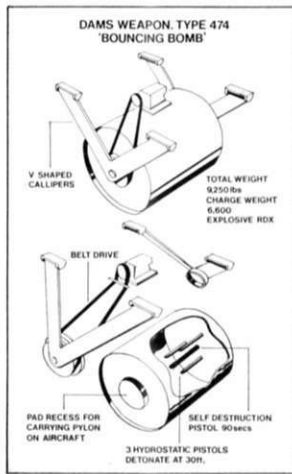

took off at 21.10 hours on the 16th. Nineteen Lancasters in all took part in the raid—a total of 133 men. Some, like Gibson himself and his crew, were involved in two attacks (on the Möhne Dam and then the Eder) in the one night. One crew approached the Möhne Dam no fewer than six times before getting into position accurately to release their bomb... and returned safely home, though without the aircraft. They were shot down crossing the Dutch coast, and picked up from their inflatable dinghy. Two aircraft were shot down with a total of three survivors who became prisoners of war. Some never even reached their targets. Of the 133 who set out, only 80 survived.

But the operation was a success. Over 300,000,000 tons of water swept down the Ruhr Valley, accomplishing (in the words of the official German report) "a dark picture of destruction" within a few hours. Guy Gibson was decorated with the Victoria Cross by King George VI, but he and a number of other survivors of the dam-busting raid of 16th May 1943 were killed on later raids.

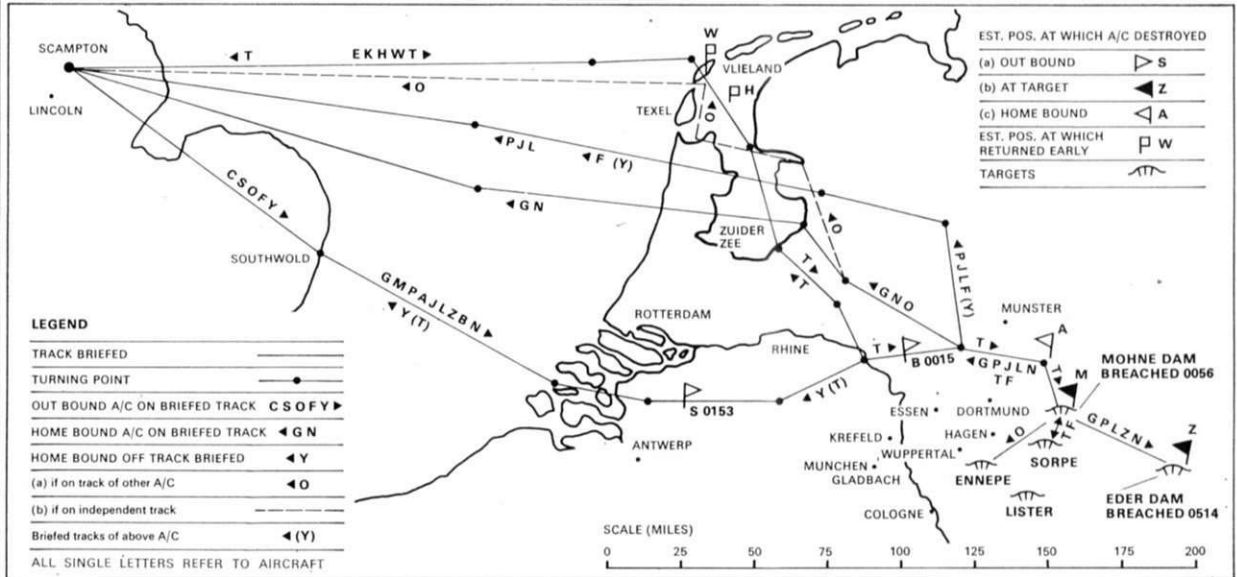

### Fly in the 'last of the Lancasters'!

A flight in one of the last surviving Lancasters, together with cameras and other prizes, can be won in an easy competition for Revell modellers! Send the coupon for details, rules and free Entry Form. No age limit—anyone can win!

Only Revell's Lancaster kit is a true Dambuster Model, with the secret weapon designed by Dr. Barnes Wallis. Make sure you buy a Revell true-to-life kit! If you have already made the Lancaster there are over 60 other

World War I & II aircraft in the Revell range. There is the new Boeing Fortress IIA which entered service with R.A.F. Coastal Command in 1942. In 1/72nd scale. Or, you could make the Supermarine Spitfire which fought in every major R.A.F. battle from 1939-1945.

For light entertainment, there is the Baron and his Fünfdecker Fokker. Just a few of the models, in the popular scales, which will be released by Revell during 1972. Many more exciting models and promotions will be coming your way—keep tuned to your Revell stockist. Over and out!



Revell Limited, Cranborne Rd, Potters Bar, Hertfordshire.

Please send Entry Form for the 'Last of the Lancasters' competition.

Name \_\_\_\_\_  
 Address \_\_\_\_\_  
 \_\_\_\_\_  
 Post Code \_\_\_\_\_

**Revell** REVELL (GB) LIMITED  
 Cranborne Road  
 Potters Bar, Hertfordshire  
 Tel: Potters Bar 58261

# Webley Hawk the two-in-one air rifle



The versatile new Webley Hawk is one of the world's greatest air rifles. With two quickly inter-changeable barrels, it is equally suitable for field or target use.

In the field, the .22 Hawk has the punch and power of .22 calibre to deal swiftly with any kind of small vermin. With its smoothly contoured stock, Monte Carlo cheek piece and pistol grip, it has the lean lines, balance and feel of a great rifle.

Back home, the barrels can be swapped over in seconds. Now the Hawk is all ready for .177 target shooting. The adjustable blade foresight and click-adjustable rearsight give sophisticated sighting for real accuracy and tight groupings. What more could anyone want from an air rifle?

Webley Hawk. Available with either .177 or .22 barrels (£15.15) or with both barrels, target cards and pellets (£19.98). For even greater accuracy, two telescopic sights are available as optional extras (£3.63 and £5.46).

**Webley Hawk.**

**All the air rifles you ever wanted.**



**With Webley you're sure  
of a great gun.**

For fully illustrated catalogue on the Hawk and all other Webley air rifles, pistols and accessories, please write, enclosing a 10p stamp to

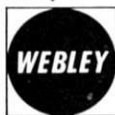

**WEBLEY & SCOTT  
LIMITED**

(inc. W. W. Greener Ltd.)  
Dept. E352, Park Lane,  
Handsworth, Birmingham B21 8LU



# No Firing

Models like Plasticine,  
sets as hard as stone

## 'PLASTONE'®

You don't need a kiln when you  
model in Plastone, the perfect

medium for modelling permanent ornaments. It sets rock-hard without oven-baking, ready for painting in oil colours or varnishing. Made by Harbutts, world-famous for Plasticine, Plastone is sold in ¼ lb. sealed tins.

Available from most  
dealers in artists  
materials.



A **Harbutts** PRODUCTION

Sole manufacturers:

**Harbutts' Plasticine Ltd., Bathampton, Bath BA2 6TA**

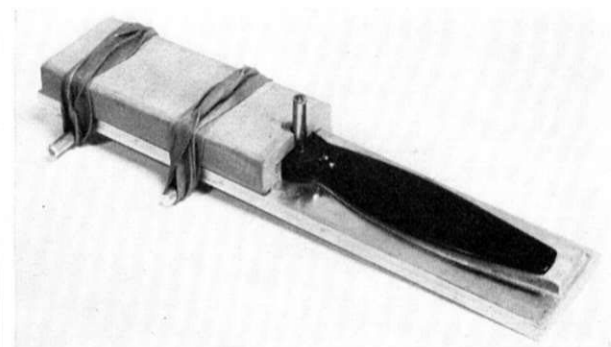

Making your own propellers need no longer involve laborious carving of a piece of hardwood, nor is it a task for 'experts only'. Jim McCann described his very successful technique of casting carbon fibre reinforced plastic props, detailing all the processes from making the mould to balancing the finished product, all without the use of any special tools or facilities.

'T-Bird' is a combat model with a difference—it may be built in two different forms to provide either a combat trainer or a 'proper' competitive machine. Ideal therefore, for either the beginner or the expert—the choice is yours! John O'Donnell examines the current crop of variable-camber winged power models, and gives his views and advice on their applications and usefulness.

Working drawings are provided of a top Czechoslovakian team racer, featuring a glass fibre fuselage, while once again the popular Gadget Review feature reveals hints and tips to help your modelling.

All this, plus regular features too, in the May issue of Aero Modeller, on sale April 21st.

**Aero  
Modeller**

**ON SALE  
APRIL 21st  
PRICE 15p**

# TALLY-HO - BANDITS AT 3 O'CLOCK!

Another  
**NEW Dinky**  
plane!

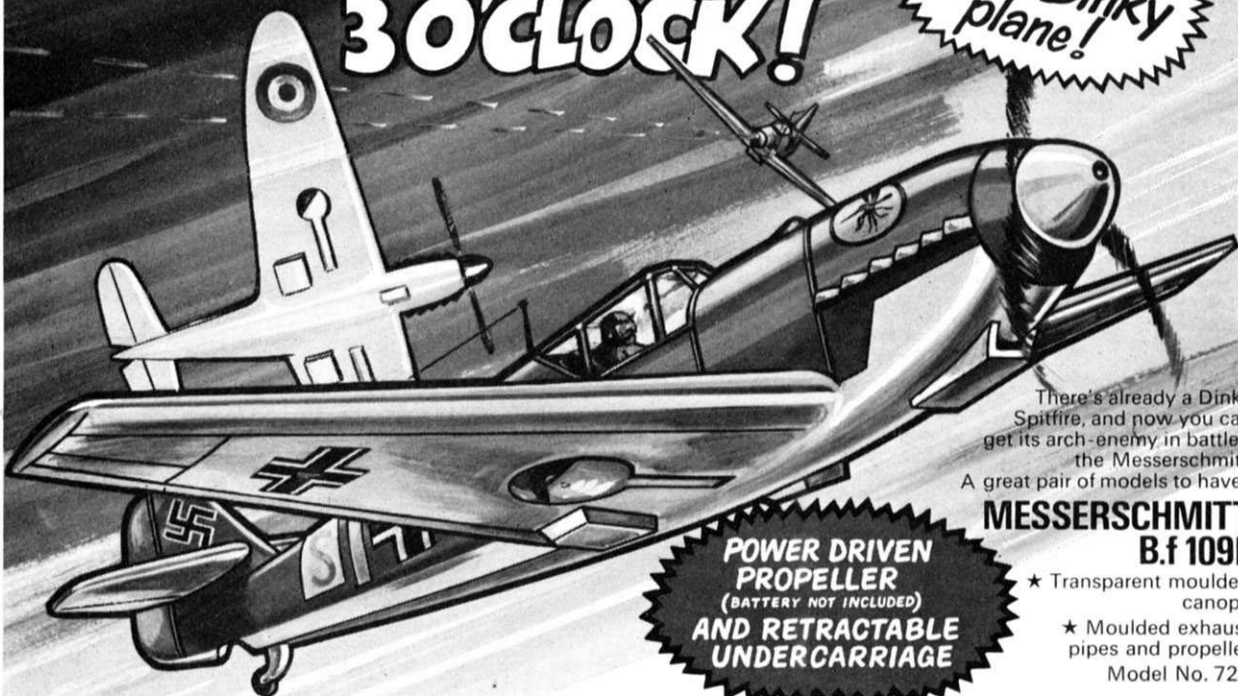

There's already a Dinky Spitfire, and now you can get its arch-enemy in battle—the Messerschmitt. A great pair of models to have!

## MESSERSCHMITT B.f 109E

- ★ Transparent moulded canopy
  - ★ Moulded exhaust pipes and propeller
- Model No. 726

**POWER DRIVEN  
PROPELLER  
(BATTERY NOT INCLUDED)  
AND RETRACTABLE  
UNDERCARRIAGE**

BUILD YOURSELF THIS GREAT NEW

# Dinky Kit



**INCLUDES  
ELECTRIC  
MOTOR  
BATTERY NOT  
INCLUDED**

## THE SEA KING HELICOPTER

- ★ Finger-operated winch
- ★ Motor-powered rotor blades
- ★ Includes HUMBROL enamel (one colour only)

Model No. 1040



**DUPLE  
VICEROY 37  
LUXURY  
COACH**

**32p**  
Recommended  
Retail Price

WITH  **SPEEDWHEELS**

Model No. 296

# Dinky

## TOYS®

tough action-packed models

MAP

The Finest Range of Model Technical Books in the World!

### 165 MECCANO CONSTRUCTOR'S GUIDE

Bert Love, whose name will be familiar to readers of Meccano Magazine provides a wealth of useful information and ideas for both beginner and expert constructor alike in this fine new work which represents an edited edition of his series of twelve articles in Meccano Magazine. Chapter headings include Basic Construction, Pulleys Sprockets and Gears, Basic Cranes, Winding Gear, Rotating Superstructures, Movement on Rails, Traction Engines, Crawler Tracks, Vehicle Mechanics and Electrical Circuits for Motors and Lights, covering in detail every possible use and application of this versatile medium.

8½ × 5½ in. (A5), 152 pages.

Text illustrated with 135 photos, and 31 line drawings.

**£1.25**

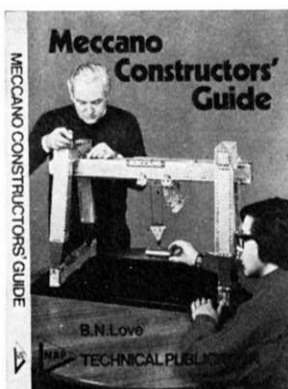

### 156 CHALLENGE IN THE AIR

The story of the Air Training Corps from its tenuous beginnings after the 1914-18 war when the idea of a youth organisation with an aeronautical flavour formed in the minds of two young ex-servicemen—to its present position as the main source of recruits for the Royal Air Force. The story unfolds via the formation of the Air League's Air Defence Cadet Corps, through the difficult days of World War 2—during which the Air Training Corps was formed—to the present day.

164 pages on antique wove paper and white glossy plates, size 6 × 8½ in., being 128 pages of text, and 35 pages of illustrations. Bound in linson, with gold foil blocked title on spine and **£1.75** colour. Dust cover.

### CHALLENGE IN THE AIR

The story of the  
Air Training Corps  
Bryan Philpott



### 117 SOLARBO BOOK OF Balsa MODELS



About Balsa and Working with Balsa; Boxes and Cabinet Racks... a Birdhouse; Solid Balsa Carved Figures; Space Frame Models; Balsa Bridges; Carved solid models—aircraft, cars, ships; Carving Propellers; Chuck and Catapult Gliders; Whip Control Models; Boomerangs; Kites, Helicopters; Simple Ship Models, water line-ship models, power models; Prop-Hydro; Round Bilge Hulls; Submarine; Kon Tiki Raft; Catamaran; Scale Car and Roadside Models; Trackside Models, Airport Buildings; Architectural Models; Military Models; Puppets and Puppet Theatres, Airspeed Indicator/Beam Balance; Slide Rule, Micrometer, Caliper rule; Two-stroke engine. Picture sequence on finishing Balsa Models... Text and photos.

10½ × 8½ in., 112 pages.

**75p**

### 163 MODEL RAILWAYS LOCOMOTIVE ALBUM

A compendium of beautiful photographs and articles of interest to the railway modeller and historian. It ranges from nostalgic memories of tinplate and pictures of specimens collected to a typical day's work at Crewe in the heyday of steam. Then there is the Story early model locomotive by a youngster who made his name in another field of endeavour; Pressure on Designers; plus a pot pourri of articles and pictures covering nearly every facet of the railway enthusiast's interests in a thoroughly adult manner.

112 pages, size 9½ × 7½ in. Two colour cover.

**95p**



### 151 SEA BATTLE GAMES

The rather neglected aspect of naval wargaming is here treated in fine detail. Author P. Dunn has been playing sea battle games for a number of years and has wide experience of the various methods of playing advocated. The ideal period for naval wargame ended when ranges got so great that battles were fought with ships over the horizon, so that the author deals in great detail with Napoleonic period, Ironclads and pre-Dreadnought gunnery systems, with a chapter on early periods—armada and similar. Of special interest are his rules for map campaigns and a hypothetical world war game.

7½ × 4½ in. 176 pages, hard bound in linson boards, with full colour dust cover specially painted. Profuse line drawings, tables, etc. **£1.25**

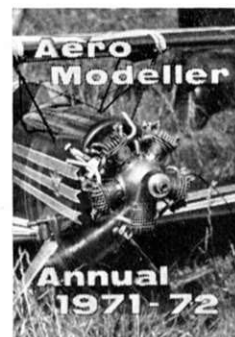
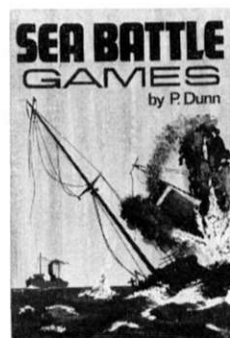

### 160 AEROMODELLER ANNUAL 1971/72

Four dozen of the top model aircraft designers culled from a dozen countries give a balanced appraisal of modern aeromodelling. Survey of free flight contest tactics. How to do aerobatics with control line models; Flying radio controlled thermal soaring gliders; Making sheet balsa models; The effect of altitude on model flying; Use of twisted wings; Towing a glider with a Power Model; Variable camber power models; Engine Fuels... plus countless hints and tips. This pot pourri of all that's best in 1971 will be extremely popular with a broad range of interests in Aeromodelling.

128 pages, size 8½ × 5½ in. Coloured cover (photo) bound boards. **75p**

MAP

HOW TO ORDER. Ring round the reference number of the titles you have chosen. Carry out totals to cash column and then total up at the bottom. Please add 5p packing and postage for orders of 62½p and below, 7½p over 62½p up to £1. Above this orders are POST FREE.

117 . 150  
151 . 156  
160 . 163  
165

Name .....

Address .....

£

MODEL & ALLIED PUBLICATIONS LTD. 13/35 Bridge St., Hemel Hempstead

KINDLY MENTION "MECCANO MAGAZINE" WHEN REPLYING TO ADVERTISEMENTS



### Full-size for Matchbox

It will probably be no news to keen car racing enthusiasts that Lesney Products & Co. Ltd., best known as the makers of "MATCHBOX" toys, have announced that they are sponsoring the Team Surtees Formula 2 cars in 1972. The cars will be taking part in all the major Formula 2 events during the year and will be driven by Mike Hailwood and John Surtees himself. The picture shows the new Team Surtees TS10 Formula 2 car carrying the "Matchbox" colours of yellow, blue and red in which it will be raced. The car made its first appearance at Mallory Park on the 12th March and, despite a sad engine and tyre problems, managed a creditable 5th place out of 20 qualifiers from no fewer than 43 entries, in the hands of Mike Hailwood.

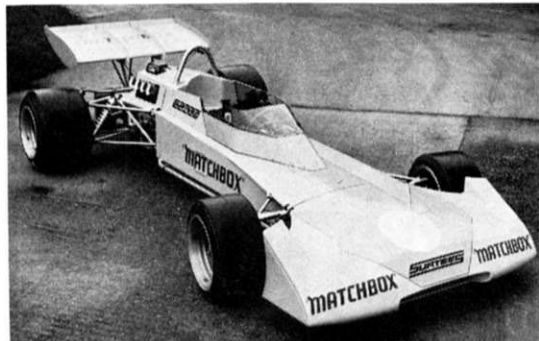

### Sir Alec Issigonis

Details of a grand Meccano Competition are announced on page 253 of this issue, and it will be noticed that one of the judges is Sir Alec Issigonis, who is undoubtedly best-known for the design of the Mini.

The photograph on this page shows Sir Alec on the occasion of a "retirement" presentation at the end of last year; one of his parting gifts, presented to him by George Turnbull, Deputy Managing Director of British Leyland, was a No. 10 Meccano outfit. This gift was made because Sir Alec, though officially retiring from the company, immediately rejoined it in the capacity of Advanced Design Consultant, and with a lot of technical problems likely to be passed his way, will almost certainly find the variety of Meccano parts invaluable for "three-dimensional doodling".

Among projects on the agenda for Sir Alec and the advanced design department are steam propulsion and hydraulic transmissions in new small car concepts. As the new consultant's chief hobby is building model locomotives, an interest in steam is assured!

The first all-Issigonis car was the Morris Minor of 1948, the first British car to reach the million in production; in fact, it was built for almost 23 years and, as a personal opinion (having owned a couple) must rank as

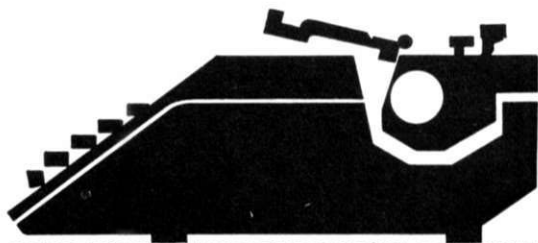

## ON THE EDITOR'S DESK

one of the major milestones in small production cars. We always thought that with a modernised body shape it would have found a continuing market for another 20 years! However, Sir Alec went on and produced the amazing Mini, which has already comfortably passed the 2½ million mark. The 1100 is also over two million; altogether nearly 7,000,000 cars have so far been built to this one engineer's designs. What he will—or, at least, could—produce from his No. 10 set is positively mind-boggling!

### Rotech's Rally Car Wins Major Rally

During the past few months, the boys of Rotech, the Motor Engineering Department of Rotherham High School, Luton, have been preparing a 1955 V.W. Beetle for rallying. This project has been part of their two year course which trains them for the Certificate of Secondary Education in Motor Mechanics.

This car has now won Britain's major all V.W. motor rally, the Volkswagen Plaistow Lupin Rally. This success is a tribute to the effort and care which the boys have put into the car.

Driven by Paul Harris, who heads the School's Science and Motor Engineering Departments and navigated by David Warren, Training Officer at Vauxhall's Dunstable Plant, the car beat some impressive opposition.



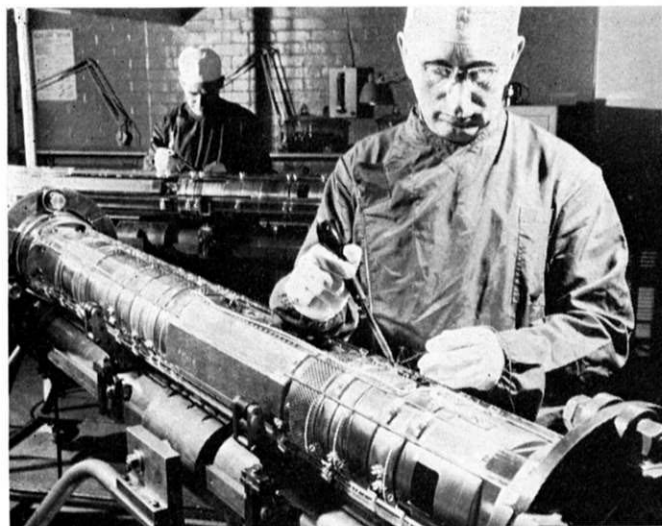

Over a quarter of a million miles of cable lie on the sea bed. The story of the development of under-water telecommunication equipment is told here by Charles Rigby

## SUBMARINE CABLES

**T**HE last few years have seen many important developments in telecommunications. The first transatlantic submarine telephone cable, TAT, was laid in 1956; and in 1967, a recorded message of the Queen, flashed across 23,000 miles, inaugurated the last section of "SEACOM", third link in the all-Commonwealth route between Britain, Malaysia, Singapore and Hong Kong. Routed from Australia to Singapore via New Guinea, Guam, Hong Kong and North Borneo, covering some 8,200 statute miles, it incorporates 356 submerged repeaters.

Telegraphic communication was made possible after a century of discovery, invention, and hard work. The beginning was in 1837, when William Cooke and Charles Wheatstone decided to work together to master electrical signal transmission. The inventors obtained a patent

and on July 25th, the first telegraphic message was flashed over a length of copper wire, sent from Euston Square to Camden Town. The world's first telegraph had only been operating a week when the railway company involved decided to dispense with it.

However, Cooke was not satisfied. After pressing for more trials, the directors of the Great Western Railway permitted him to run a line from Paddington to West Drayton. Proving successful, one company after another adopted the new means of communication, and 10 years after the erection of the first telegraph wires, England had 1,250 miles of them. By 1849, arrange-

Heading shows the wiring operations on a deep-water repeater which has to be carried out under ultra-clean conditions. Left, the scene at Kennack Sands, Cornwall, in September 1970 when laying operations were started for the U.K.-Spain submarine telephone cable. Below is a cable portable hauler, used at a submarine cable factory at Southampton to transfer lengths of core direct from extruders to a storage area.

Photo at left and two large maps courtesy U.K. Post Office. Other illustrations courtesy Standard Telephones and Cables Ltd.

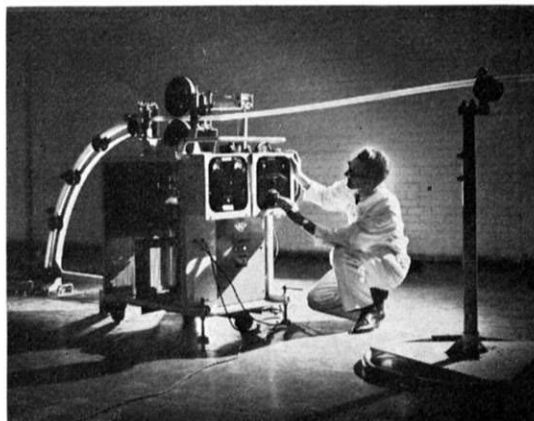

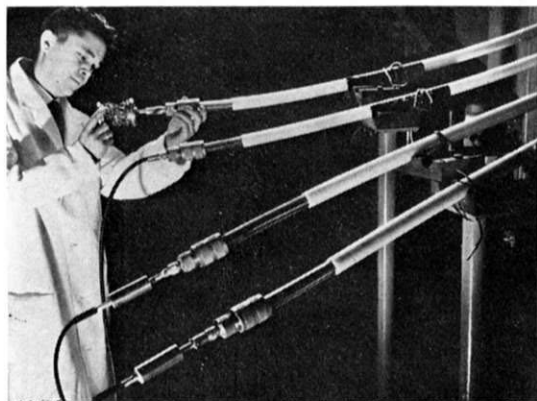

An engineer conducting transmission tests on completed lengths of a deep-water submarine cable.

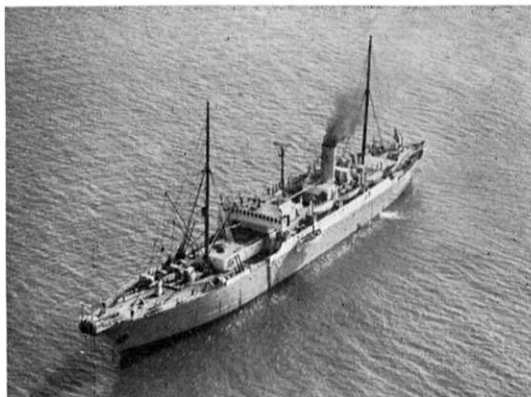

The cable ship *John W. Mackay* displaces 4,100 tons and can carry 700 nautical miles of cable and 70 repeaters.

ments were made between the Post Office and different companies for the transmission of telegraphic messages, and so the telegram was born.

Inevitably, the question arose: "Could telegraph wires be run under the sea?" The first experiment followed soon after. It took place in Swansea Bay and proved successful. The next step was the laying of a cable between Dover and Calais. Without difficulty, once more the intrepid scientists won. A cablegram, the first ever delivered, proved successful. Strangely enough, within a few hours the cable broke upon the sea-bed, the messages ceased, and the inventors were charged with having faked the first messages and the project considered a hoax. Furious at this accusation, Cooke and Wheatstone got together all the witnesses, and proved otherwise.

This experiment certainly brought to light certain

difficulties, one being the problem of insulation, which was finally solved by using gutta percha. The dawn of deep-sea cable-laying had arrived and 15 years after the first land success, F. S. Gisborne applied for a concession to link St. John's, Newfoundland with Cape Ray. He laid 40 miles of sea cable and was then held up for lack of funds. He came to London, and launched the Atlantic Telegraph Company. Naturally, there was tremendous excitement about this, yet many people considered it impossible. Before a cable was successfully laid and operated between Europe and America, three attempts had been made.

On the first attempt, when H.M.S. *Agamemnon* was laid on her beam-ends in a terrific storm, the cable snapped in Mid-Atlantic. The second attempt, however, succeeded and the first cable message was that sent by Queen Victoria to President Buchanan. Again,

# European Cable Routes

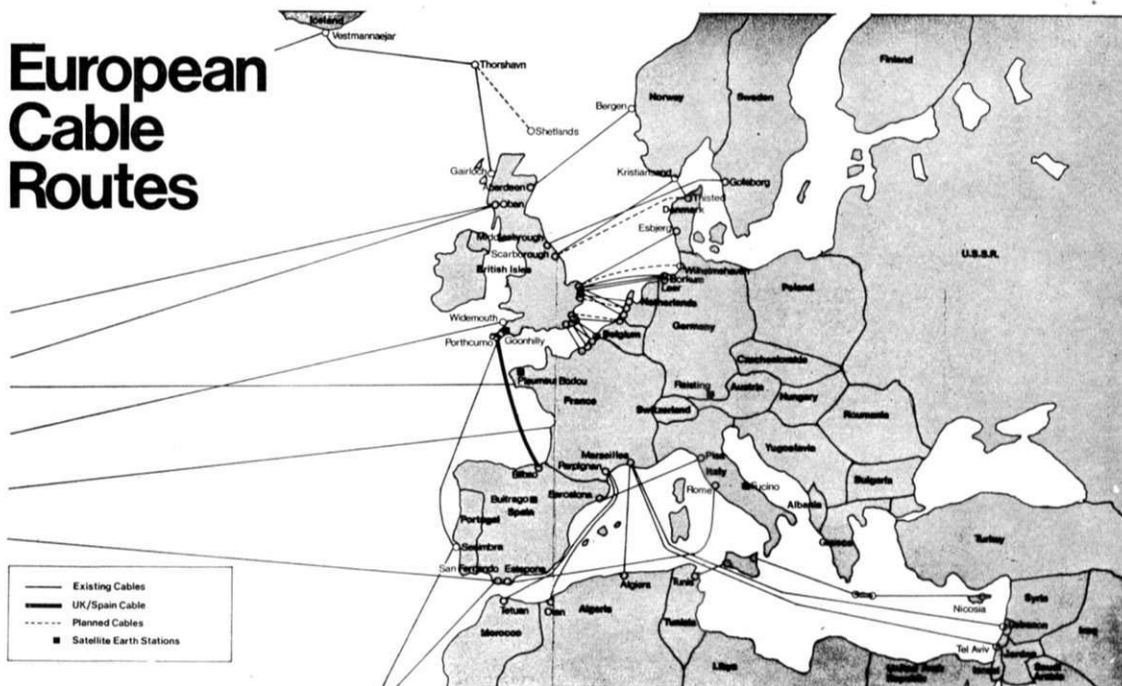

# TRANSATLANTIC TELEPHONE CABLES

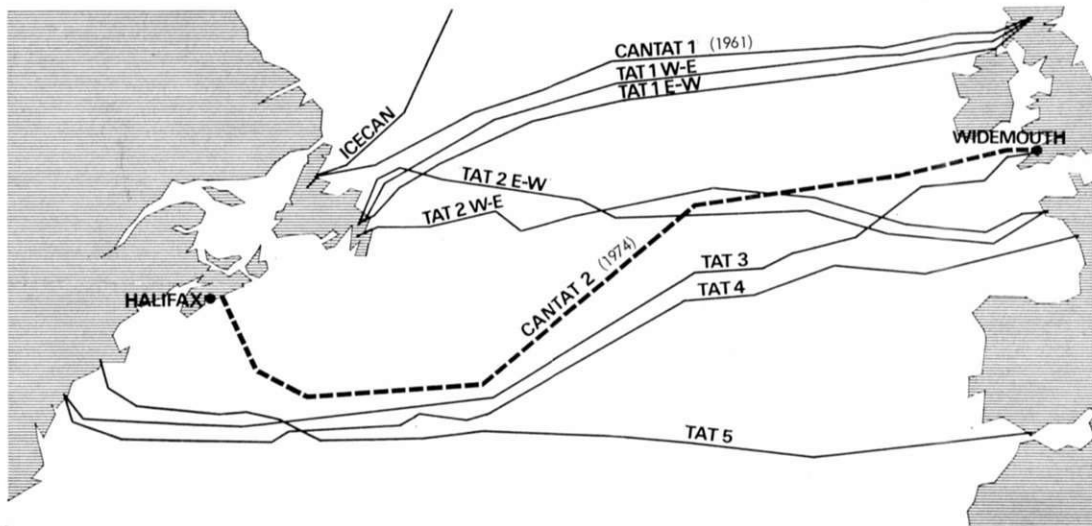

this success was short-lived. The cable worked on a very high potential and burnt out. So after all the project seemed to be a "wash-out", yet a third attempt was made. At that time, the wonder ship of the world, the *Great Eastern*, lay in the Thames, so she was converted into a cable ship for laying the cable, and in time the Atlantic was bridged.

At the outset, the average number of messages sent was 29 a day. Later, some 52,000 messages per day were handled, and these were transmitted at incredible speed—200 words per minute from land to land. Cable engineers then predicted that in the near future it would be possible to flash over cable, 9,000 words per minute. Although this seemed ridiculous, not long afterwards, from Electra House, a message was passed by Cable and Wireless via the Imperial route from London to Cape Town and back in 1½-seconds. This was made possible by perfecting the 'regenerator' which enabled several sections of a cable to be worked simultaneously over long distances without retransmission.

The first deep-sea cable had a single transmitting core of copper, but later this was improved upon with as many as 12, the central conductor being coated with jute yarn. At this time, 7 cable ships with up-to-date gear were employed. Since that time, big changes in submarine cables followed with the introduction of telephones. Earliest types were laid by H.M.T.S. *Monarch* (8,500 tons). Cable ships of today have large circular tanks instead of cargo holds, where the cable, up to 2,600 miles, as in *Monarch*, is coiled.

Special machinery is installed for laying and picking up cable, the 'sheaves' at 'bow' and 'stern' allowing for the pay-out while the ship travels at speeds up to 6-7 knots. Cable ships are also provided with dynamometers for measuring the stress on the cable as it slips into the sea, sounding apparatus for measuring depths and the contours of the ocean bed, buoys for mooring and marking, and a variety of grapnels for grappling cable on the sea-bed and bringing it up for repair.

The Anglo-American cable of 1866, like most others of that time, was of simple structure and carried telegraphy only. TAT I (1955-1956) contained a repeater every 38 miles or so distant, including valves designed to

function for up to 20 years at depths of 3 miles. During 1961, a further transatlantic cable, CANTAT, much different from the first 'TAT', was laid and contained heavier, rigid repeaters, through which messages can be sent in both directions simultaneously. Repeaters were used for the Newfoundland-Nova Scotia link of TAT I, in comparatively shallow water. The cable itself is lighter, being made to a new Post Office design.

The UK and Commonwealth submarine cable network consists of (1) 1,300 nautical miles of mainly tele-

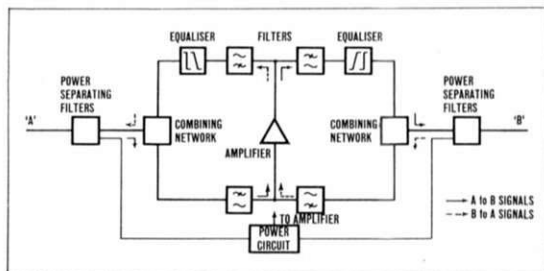

Above is a block diagram of typical submerged repeater. Below is a block diagram of typical terminal equipment for a submarine cable system.

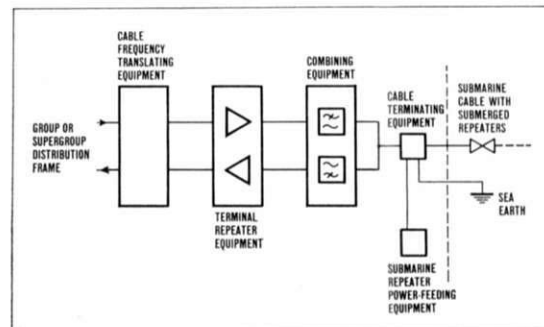

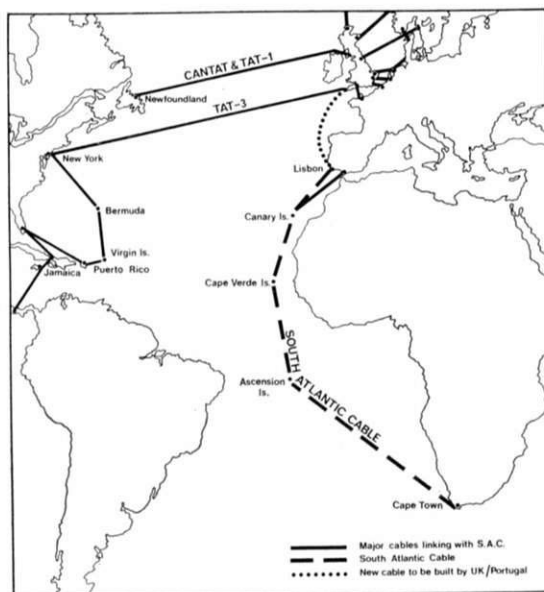

phone cable between Britain and the Continent, operated by the P.O. (2) 142,400 miles of telegraph routes under the Atlantic, Pacific, and Indian Oceans, and the Mediterranean, controlled by Cable & Wireless Ltd. and (3) the 2,300-mile TAT I between Scotland and Nova Scotia (with radio links to New York) operated by the P.O., and in Canada by the Canadian Overseas Telecommunication Corporation. A total of 144,000 nautical miles is in the Commonwealth 'Common User' system, joint policy for which—and for the Commonwealth radio telegraph and telephone circuits—is agreed by the 'Partner Governments', namely the UK, Canada, Australia, New Zealand, S. Africa, India, and Southern Rhodesia (Telecommunications Board). The British system is maintained by four P.O. ships, and eight ships operated by Cable & Wireless Ltd.

Since last year, H.M.T.S. *Monarch* has been replaced by three vessels, the *Ariel*, and *Iris*, and the diesel-electric ship *Alert*, for laying cables and repair work at any depths. The cable depots are at Dalmuir, Dover, Woolwich, and Shandon on the Gareloch. Before a cable is laid the ship has to make a thorough survey of the proposed route which is planned, if possible to avoid crossing existing cables. The ship then takes soundings at intervals to check the charted depths and topography of the sea-bed. Sometimes extra cable has to be laid to avoid undue tensions over submerged valleys. Laying a cable is not always a smooth process.

The log of *Monarch* when beginning to lay 'TAT' I in 1955 shows that off Clarendville, Newfoundland, she ran into a thick fog and sighted a large ice-berg. The chain attaching the previously laid shore end to the buoy had parted, and the ship, for part of the time riding a southerly gale, had to grapple for the lost end in 350 fathoms. Later, sailing into a westerly gale, she found the buoy had broken away off Rockall Bank, then she ran unsuccessfully across the line of the cable several times but failed to grapple. Southerly gales sprang up, and riding through rough seas and buffeted by squalls of hurricane force, and waves of up to 40 ft. high, she had to abandon the attempt before she could grapple again

Here, a submerged repeater capsule is being lowered into its high tensile steel sea-case.

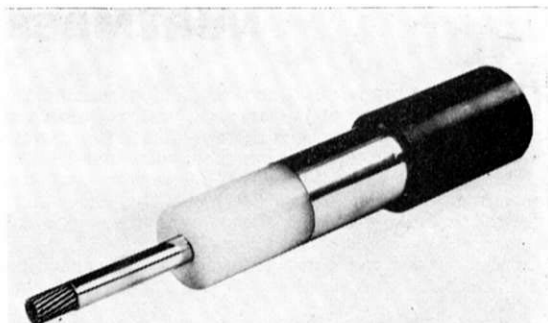

Above, a sectional length of a deep-water submarine cable. The stranded steel inner member is welded on to a copper tube inner conductor. High molecular weight polythene separates the inner from the outer copper tube and the final layer is of high density polythene.

and use the end, and splice on to the cable in her tanks, to pay-out astern.

Cables are normally laid at the rate of about 200 nautical miles a day, though the speed is slower for those with repeaters, the ship having to slow down while the repeaters are passing over the "sheaves" to the sea. A cable reaches the bottom about 3 miles astern for every 1,000 fathoms of water. Apart from the giant undersea cables linking Britain with countries abroad, there are 350 underwater cables in the national network, totalling 2,000 miles. One of the shortest, a one-mile cable, joins Kyle to Kyle Akin, Skye.

Communication satellites are carrying an increasing number of telephone calls between Britain and the U.S.A. and elsewhere in North and S. America, but the Post Office believes that use of both cable and satellite will continue to be valuable in providing complementary transatlantic communications.

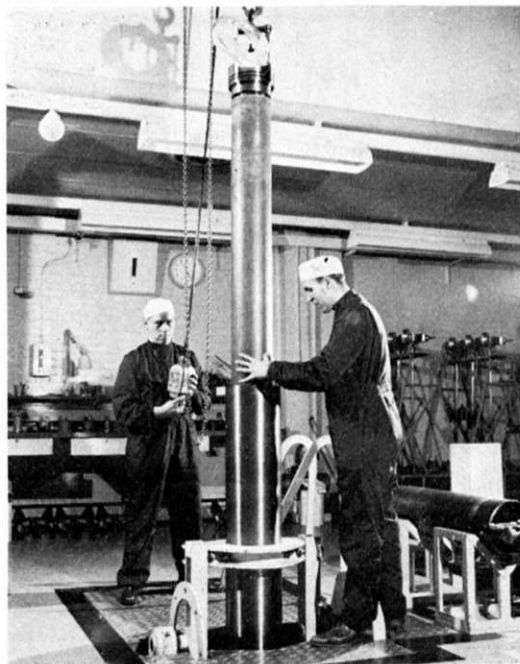

## NUREMBERG TOY FAIR

THE biggest toy fair in the world, held at Nuremberg around the end of January each year, is on such a scale that unless you've been there it is hard to imagine its size and scope. This year there were over 3,000 exhibitors, just about all of whom had new products to show in addition to their established lines, and they spread over nine main halls with a total area somewhat in excess of Earls Court and Olympia combined! Next year the Fair will move into a massive new site specially built for this purpose just outside Nuremberg.

Buyers come from all over the world, and there is strong international representation among the exhibitors. Quite a few British firms had stands, including, of course, Meccano (1971) Ltd., and there were many British buyers present, so that quite a few of the goods on show will eventually be appearing in British shops.

As one would expect, most of the items on show at a toy fair are toys pure and simple—dolls, balls, roller skates, games, and so on—but with so vast a gathering, even the "fringe" goods such as model kits and accessories form in themselves an enormous display. Many of the kits etc. are revealed for the first time at the fair, which gives advance information to magazine editors etc. on what will be reaching the shops during the year, though of course the main purpose is to enable store buyers and/or import firms to place orders, on the basis of which the makers can plan production flow.

It would be remarkably difficult to attempt to list all new items, even if the space was available, but among those that caught the eye were the new  $\frac{3}{32}$  scale Frog Focke-Wulf 190A and Zero, and Airfix's  $\frac{1}{24}$  P51D Mustang was attracting a lot of attention (mentioned in our March issue, by the way). Revell have several new kits coming along, among which are three  $\frac{1}{32}$  aircraft, Mosquito, Focke Wulf 190D, and Messerschmitt 262A, several new cars, motor bikes in both  $\frac{1}{8}$  and  $\frac{1}{12}$  scale, and a most attractive 30 in. model of a sixteenth century English man o' war. There was quite a selection of new Japanese kits, prominent being a  $\frac{1}{24}$  scale Zero from Bandi and Tamiya's  $\frac{1}{48}$  scale Hawker Siddeley Harrier.

In the die-cast field, Politoys are becoming better known in U.K. with a considerable range of  $\frac{1}{33}$  and  $\frac{1}{45}$  scale die-cast cars, now being imported by Model-Time and A. A. Hales Ltd. Dinky Toys have, as ever, a number of intriguing new items lined up for the coming months, one that was particularly outstanding being a gyro-operated Pink Panther mobile. Another of the big die-cast names, Matchbox, are branching out into toys and games this year, one of the first "things" (and we do mean "things") being some little items working on balloon power, which we expect to be reviewing in next month's issue.

Some of the items mentioned, and others, are shown in our photographs. As and when others are released, we hope to keep you in touch.

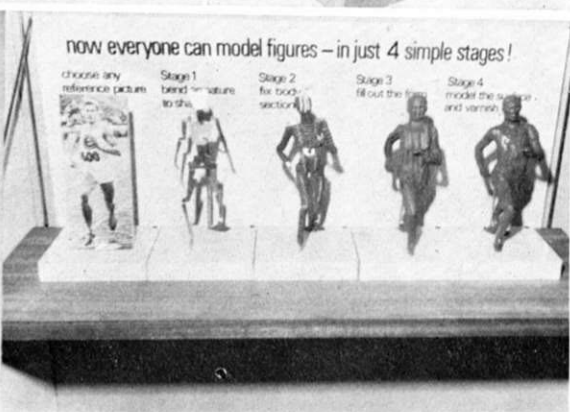
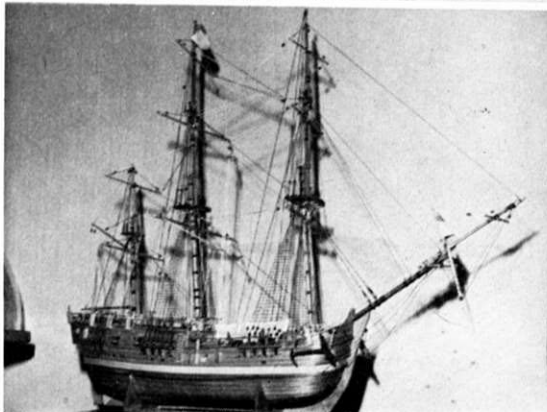
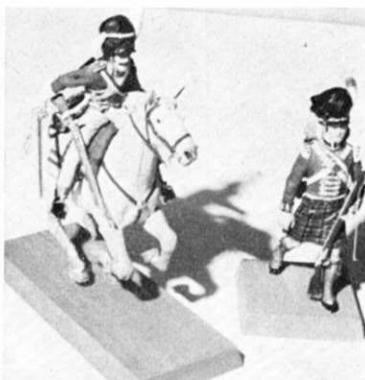
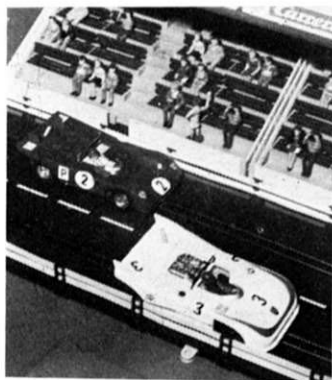



Above left, Revell's new racing Porsche 911 and, right, Tamiya's superb 1/48 scale Hawker Siddeley Harrier. Opposite Page, top from left to right, two new 1/24 scale slot racers from the German firm of Carrera, an outstanding Volkswagen from Politoys (weird!) and two new 54 mm. Airfix figures, a 42nd Highlander (Black Watch) and a Scots Grey. Bottom, one of Mantua's new kits from Italy is Captain Cook's H.M.S. Endeavour, largely modelled in walnut; importer for these kits is H.G.H. Models Ltd. of Richmond. The four-stage figure is the classic clay-moulding technique available in model kit form for the first time; from A. A. Hales Ltd. Below, top, two detailed 1/25 scale die-casts from Politoys and Frog's  $\frac{1}{32}$  scale Zero, which we understand will be available soon. Centre, ready to go glowplug engine free-running cars by Cox, Baja Bug, Chopper, and AA Fuels Dragster plus (right) the newest, Ford Pinto Funny Car Dragster. Bottom, more new Frog kits, Heinkel He111 and H-S Buccaneer, both supplied with alternative markings in kit, and lastly, one to please football fans, Airfix's  $\frac{1}{32}$  set, which includes two teams, two trainers, two linesmen, two footballs, and one referee.

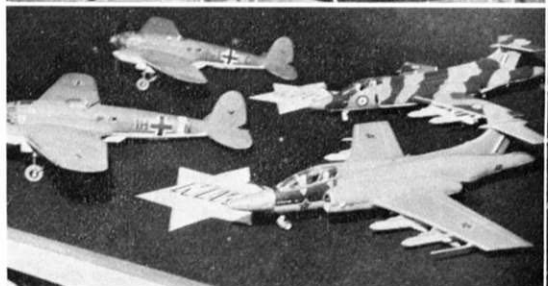
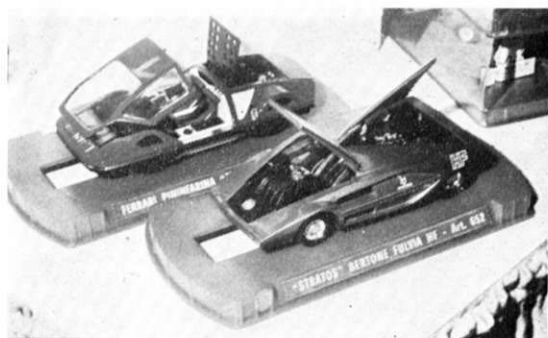



**L**AST July, millions of television viewers the world over saw vehicular history in the making when they watched "live" pictures of the first ever passenger-carrying "car" to go trundling around the eerie surface of the moon. That, of course, was America's Lunar Roving Vehicle, shipped up to the lunar surface by the Apollo 15 moonprobe and, although it could hardly be described as a "luxury limousine", it still stands out in my mind as the most famous vehicle of the century. You might say, "It's out of this world"!

It hardly seems possible that only a few short years ago the idea of human beings driving sedately around the moon was not to be considered outside the pages of science fiction novels. Now, not only have astronauts David Scott and James Irwin done that very thing on the Apollo 15 mission, but

the Apollo 16 landing crew will become the second pair of motorised moon travellers sometime after this Magazine hits the bookstalls. At the time of writing, Apollo 16 is scheduled to blast off from Cape Kennedy in the second half of April, crewed by John W. Young, the commander, together with Thomas K. Mattingly and Charles M. Duke. Assuming plans are not changed between now and then, Thomas Mattingly will remain orbiting the Moon in the Command Module, while John Young and Charles Duke will land in the Lunar Module, taking an L.V.R. (Lunar Roving Vehicle) along with them.

Looking rather like a motor chassis with seats, the L.V.R. is a unique, designed-for-the-job vehicle. It was developed by the Boeing Company of Huntsville, Alabama with the "mobility system"—wheels, suspension, traction and drive—being supplied by the General Motors AC Electronics Division at Santa Barbara, California. Drive is supplied by four separate electric motors, one mounted on each wheel hub and powered by solar batteries carried on a platform between the front wheels. Overall length is 10 ft. 7 in., width almost 6 ft. and wheelbase 7 ft. 6 in.

Weighing 400 lbs (earth-weight) unladen, it is capable of carrying two astronauts with their life-support systems, plus 100 lbs of scientific experiment equipment and 70 lbs of lunar rock and soil samples, all this resulting in a total laden weight of 970 lbs. From a standing start, it will successfully climb over

Heading, in realistic setting, the new Dinky Lunar Roving Vehicle, No. 355, carries its astronauts on a journey of discovery.

Above left, a detail view of the Dinky L.R.V. showing the method of working the steering system.

Left, an artist's impression of a real Lunar Roving Vehicle under power on the moon's surface.

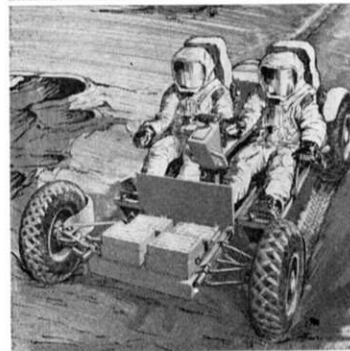

## DINKY TOY NEWS

# OUT OF THIS WORLD

by Chris Jelley

step-like obstacles up to a foot high and can cross cracks or crevasses as much as 20 in. wide. Thanks to a low centre of gravity, coupled with its long wheelbase and wide track, in proportion to overall length and width, it will even negotiate 25 degree slopes—equivalent to a 4 in 1 hill—and that's steep!

With an operational lifetime of 54 hours during a lunar day, it has a range of 75 miles, although in practice, this distance would be split up into a series of much shorter sorties rather than one long trip. In fact, the astronaut is officially limited to a maximum distance of only three miles from their spacecraft at any one time because of the duration of their life support system. It must be remembered, of course, that there is no atmosphere on the moon so that, whenever the astronauts are outside their ship, they must wear space-suits complete with an air supply and heating and cooling systems. Without the first, they would be unable to breathe; without heating they would freeze to death in the shade, and, without cooling, they would be fried in the sun! Obviously, the amount of air that can be carried is limited—hence the comparatively small sphere of operations.

A particularly interesting feature of the L.R.V. is its steering system. Unlike the conventional 4-wheel car which has steerable front wheels, controlled by the driver's steering wheel, the L.V.R. has steerable front and rear wheels, controlled by a small lever which is included in a compact pedestal console, handily positioned between the two astronauts. The rear wheels steer in the opposite direction to the front wheels, a feature that succeeds in bringing the turning circle down to a remarkable 20 feet. My Mini car is a lumbering oaf by comparison!

### Dinky L.R.V.

So far I have mentioned nothing but the real Lunar Roving Vehicle, and readers may be politely wonder-



ing by now what significance it has to this feature. Well, obviously, the answer is that Dinky Toys have chosen the L.R.V. as inspiration for a new model, just released under Sales No. 355. Looking at the first production sample to appear on my desk, they have made an excellent job of it, too! The strong, chunky casting not only incorporates wealth of general feature detail, but also includes sparkling representations of the original's solar batteries in front and simulated equipment/sample containers at the back, behind the twin seats. Occupying the seats themselves are two space-suited "astronauts", produced in a pliable moulded plastic and capable of being removed from their seats, if required.

Positioned between and immediately in front of the astronauts is a representation of the earlier-mentioned pedestal console. As a console, this is a very basic feature including no detail of any sort other than the basic shape, but it should not be dismissed as unimportant because of its simplicity. On the contrary, it is vitally important. The model is fitted with working 4-wheel steering and the console, with its pedestal, serves as the steering control lever! Moving the console to the right causes the model to steer right; movement to the left steers the model to the left. This feature represents modeller's licence, of course, the original vehicle's console not actually moving, but it really makes the Dinky a sure-fire winner! As with the original, incidentally, the mudguards on the model (should I say "dustguards" for the moon?) swing with the wheels as the steering attitude changes.

Overall finish is in a light metallic blue, with bright-plated wheel hubs and solar batteries and orange tops to the equipment/sample containers, the latter not opening, by the way. The console is white, as also are the astronaut's space-suits, although their helmet visors are gold, their chest equipment black and their mittens and boots deep blue. In addition, each has a red "badge" on his left arm which adds an unexpected splash of colour. Approximate overall dimensions work out at  $4\frac{1}{16}$  in. long  $\times$   $2\frac{1}{8}$  in. wide  $\times$   $2\frac{1}{8}$  in. high, the last figure including the astronauts. All in all, my verdict is an unusual and very pleasing model.

The new Coles Hydra Truck 150T, Dinky Toy No. 980, closed down ready for travel.

Meccano has many uses! Here our photographer has used a few Angle Girders to represent the framework of a building under construction—with the help of the Dinky Coles Hydra Truck.

### Hydra Crane

Talking of unusual models, regular Dinky Toys collectors may perhaps have noticed that, for the past 12 months or more, the Company has concentrated on really interesting and unusual productions. Except for one or two cars last year, there has not been one model that could be termed "ordinary" for some considerable time. We have had such things as a bus, a road-sweeper, character merchandise from T.V. programmes, aircraft, and so on: all "different", value-for-money models, packed with action features. The new L.R.V. is a typical example and so, also, is the model which Dinky have released with the L.R.V.—No. 980 Coles Hydra Truck 150T.

In my opinion the description "Truck is misleading, although this is the word used for the real-life vehicle. I regard a truck as something that carries a load, whereas this vehicle is one of the modern telescopic jib cranes, as a glance at the accompanying illustrations will show. No matter what word is used, however, the new Dinky is a masterpiece in miniature, combining scale reproduction with action-packed working features. Dinky have a long tradition of outstanding mobile cranes behind them; I am prepared to say that the Hydra beats the lot of them!

Before looking at the model, a few words on the original vehicle are in order. According to the specification leaflet supplied by the manufacturer, the British Crane and Excavator Corporation Ltd., the Coles Hydra 150T "is a self-propelled, diesel-hydraulic, one-man operated, fully slewing mobile crane on a specially-designed crane-carrier chassis fitted with hydraulic outriggers. The travel motion is driven direct by the diesel engine via a

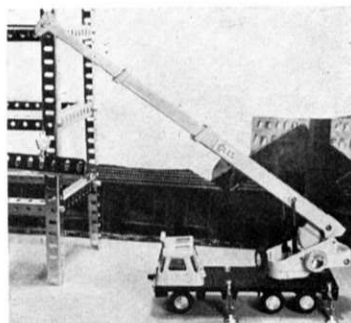

multi-speed gearbox and normal automatic controls are provided. A power take-off on the gearbox drives the tandem hydraulic pumps that power the rams and motors of the various crane motions... Outstanding features are the telescopic boom actuated by a large diameter hydraulic ram and lacing chain providing automatic synchronisation of telescopic sections, three-speed hoist providing infinite speed variation, and independent or simultaneous operation of crane motors". This more or less covers it, although I should just like to add that the telescopic boom referred to is made up of three sections, one fitting inside the other, while the engine is an A.E.C. AV505, 6-cylinder, water-cooled diesel unit of 8.2 litre (8,200 c.c.) capacity which develops a power output of 158 b.h.p. at 2,200 r.p.m.—and that's no mini engine!

Coming to the Dinky Toy, this is one of those fully-operational models that nobody—of any age—can resist "trying-out" at the first opportunity. Bodily, it reproduces all the major features of the original, from a fully glazed and upholstered cab to a working telescopic crane and stabiliser legs, or outriggers, all carried on a 6-wheeled chassis.

From a play-value point of view, of course, the crane section is the most fascinating. This rotates through a full 360 degrees and

(Continued on page 252)

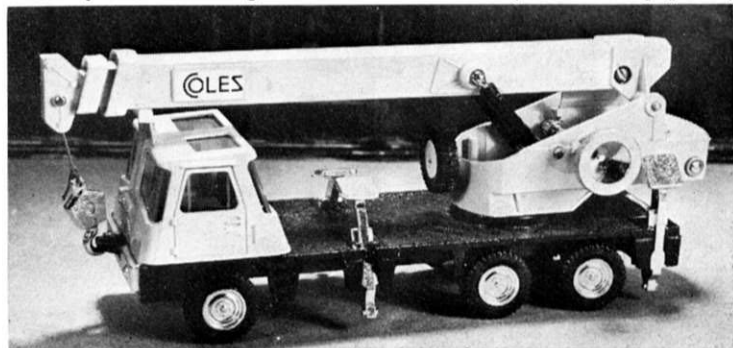

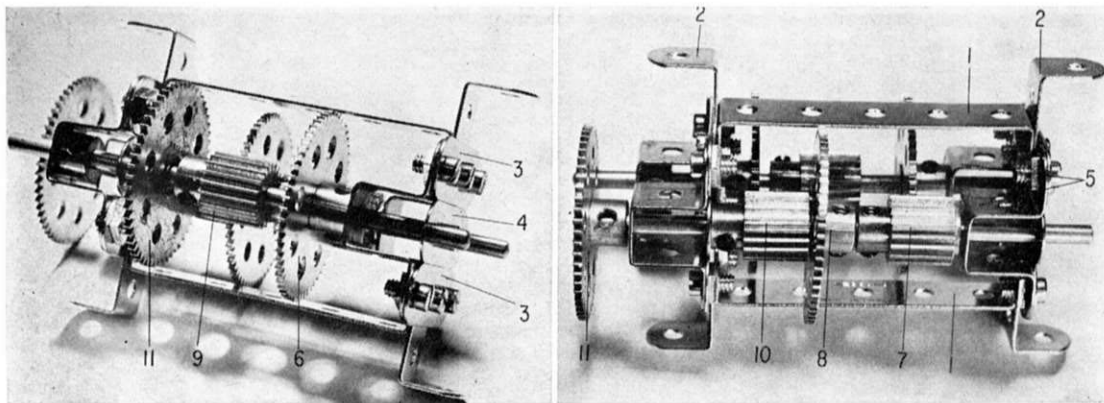

## AMONG THE MODEL BUILDERS *with Spanner*

THIS month, I am afraid, I must abandon my usual practice of writing a few introductory words of general comment. We have quite a few things to cover, so rather than waste space, I would like to get straight down to business with the Reduction Mechanism illustrated here. Based on a design by Mr. N. Muallem of Ramat-Gan, Israel, it is an extremely compact

unit offering a ratio of 27:1 which could be very useful where a steady but slow speed is required.

A simple framework is built up from two horizontal  $2\frac{1}{2} \times \frac{1}{2}$  in. Double Angle Strips 1, connected together as shown by two similar Double Angle Strips 2, vertically-mounted, the securing Bolts in each case also holding two horizontal  $1\frac{1}{2}$  in. Strips 3 in position. A

third  $1\frac{1}{2}$  in. Strip 4 is bolted to the Double Angle Strip, in between the first two Strips, then two Double Bent Strips 5 are secured to Strips 3, one each side of the Double Angle Strip.

Journalled in Strip 4 and one Double Bent Strip 5 at one end is a 2 in. Rod carrying a 57-teeth Gear 6, a  $2\frac{1}{2}$  in. Rod in the other Strip and Double Bent Strip carrying a  $\frac{1}{2} \times \frac{1}{2}$  in. Pinion 7 and a 57-teeth Gear 8. Each Rod is then inserted, free, half-way in the bore of a  $\frac{1}{2} \times \frac{1}{2}$  in. Pinion, numbered 9 on the first Rod and 10 on the second, Pinion 9 being fixed on the end of a 2 in. Rod and Pinion 10 on a  $1\frac{1}{2}$  in. Rod. These last Rods are journalled in Strip 4 and Double Bent Strips 5 at the other end of the framework, both Rods also carrying a 57-teeth Gear 11, positioned as shown. The 2 in. Rod is held in place by a Collar.

Input drive to the mechanism is taken to Gear 11 on the  $1\frac{1}{2}$  in. Rod, while the Rod carrying Gear 6 serves as the output shaft. The input Gear, of course, could be replaced by any suitable connecting link, while the lengths of the input and output shafts under operation conditions would depend on the particular uses to which the mechanism was put. The unit as a whole, of course, is a compound gear train, made up of three 3:1 ratios, thus giving a reduction of 27:1 between input and output.

Heading photos, an extremely compact 27:1 Reduction Mechanism, based on a design supplied by Mr. N. Muallem of Ramat-Gan, Israel.

Left, George Stephenson himself could not fail to admire this excellent model of his famous "Rocket" locomotive, built by Mr. C. Potter of Chatham, Kent.

Bottom left, another superb model by Mr. Potter is this detailed veteran, reproducing a 1904 Singer in feature and a atmosphere.

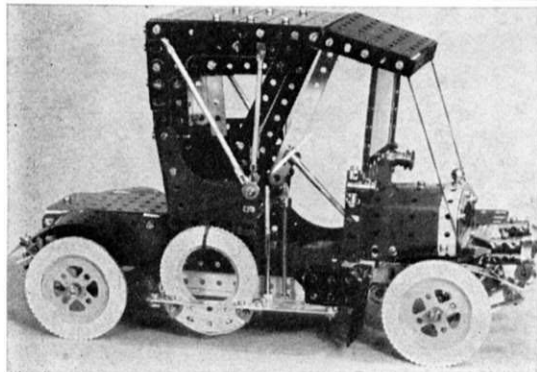
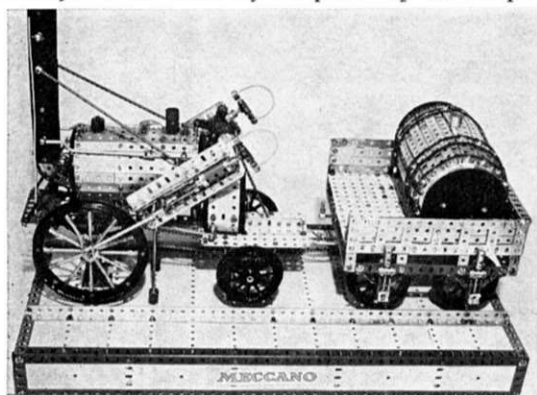

### PARTS REQUIRED

6-6a	3-26a	1-38
1-16a	4-27a	4-45
2-17	14-37a	4-48a
1-18a	14-37b	1-59

### Ratchet Mechanism

Moving on, we come next to a built-up ratchet mechanism, developed as an exercise by one of our own staff to incorporate the new Cam. Admittedly, as a built-up unit, it is more expensive than the Ratchet Wheel and Pawl in the standard Meccano Part range, but it still makes an interesting item worthy of mention here.

A 1 in. Double Bracket 1 is pivotally mounted by its lugs on a 1½ in. Bolt secured in a Face Plate 2. One end of a Tension Spring is also carried on the Bolt, this Spring being stretched over a ½ in. Double Bracket 3, fixed to the Face Plate, and its other end held on a ¾ in. Bolt fixed by Nuts in the Face Plate. The Face Plate itself is mounted free, on a Rod, being held in place by a Collar on one side and a Cam 4 on the other. The action of the Tension Spring on Double Bracket 1 holds the Bracket in contact with the Cam and thus, because of its shape, the Cam is permitted to revolve only one way.

As already mentioned, the mechanism was developed as an exercise, without too much thought to cost. The cost could be reduced, however, by substituting a Driving Band for the Tension Spring and a ½ in. Bolt for Double Bracket 3, but the following Parts List applies to the unit as illustrated.

#### PARTS REQUIRED

1-11	7-37 b	1-59
1-11a	1-38	1-109
1-37a	1-43	1-111
		1-111d
		1-131

### Stephenson's Rocket

For more general interest, now, I would like to draw attention to the accompanying photograph of that most famous of steam locomotives, Stephenson's "Rocket", modelled for us here by Mr. C. S. Potter of Chatham, Kent. The "Rocket" has, of course, been modelled many times in Meccano and Mr. Potter certainly does not claim his version to be the finest example ever built. In fact, he makes no claims at all, but I, on his behalf, would like to say that, although Mr. Potter's model might not be the finest ever built, it is certainly amongst the best I have ever seen modelled in Meccano.

"The reason for making the Rocket", writes Mr. Potter, "was to get away from the usual method of producing large wheels from Hub Discs. I have built them up from Circular Girders, with Axle Rods providing the correct number of spokes and being held on the outside of the wheel by Rod and Strip Connectors. The centres, when adjusted correctly, are clamped between ¾ in. Washers, while the flanges are formed from 2½ in. Curved Strips.

"As is clear from the photograph, the smaller wheels are standard Spoked Wheels, their flanges being supplied by 2½ in. Stepped Curved Strips gripped on the wheels by Angle Brackets. The boiler is formed from overlapping 5½ in. Strips, bolted to Strip Plates then held neatly in place between two Ball Thrust Race Flanged Discs, all secured in position by one Screwed Rod running through the centre. All the locomotive wheels are sprung, as also are those of the

tender, while motive power is supplied by an E15R Electric Motor driving the model through Sprocket Wheels and Chains. Screwed Rods played a big part in helping me to keep the model to scale and to make it more realistic."

The excellent standard of realism Mr. Potter has achieved is perfectly clear from the photograph and, having studied it, I think all readers will agree with my own earlier comment on the model. However, just in case anybody should think that the "Rocket's" realism was achieved more by accident than design, I also feature a photograph of another and equally realistic example of Mr. Potter's skill. Veteran car enthusiasts will immediately recognise the model in question as a 1904 Singer. I am not that much of an expert myself, but I have before me an illustration of the real car and I can assure you that the model is a superb reproduction, not only capturing all the lines of the original, but also its atmosphere as well. It serves as a perfect tribute to Mr. Potter's skill.

I know of many Meccano modelers who will already be itching to build the Singer, so, before dashing off any urgent entreaties to me for information, take note—I have no additional photographs of the model, or more detailed information. Sorry! Cruel of me to whet your appetites, I know, but can anybody really blame me for showing such a marvellous model?!

### New Club

Before leaving Mr. Potter, I have one more very important piece of

(Continued on page 240)

Left, a simple, but effective Ratchet Mechanism, built up as an exercise to illustrate the use of the new Cam. Right, ten-year-old Stevenage Meccano Club member Geoff Long gets full credit for this demonstration mechanism which shows how "odd" Meccano gears can be made to mesh by using Wheel Discs for journals.

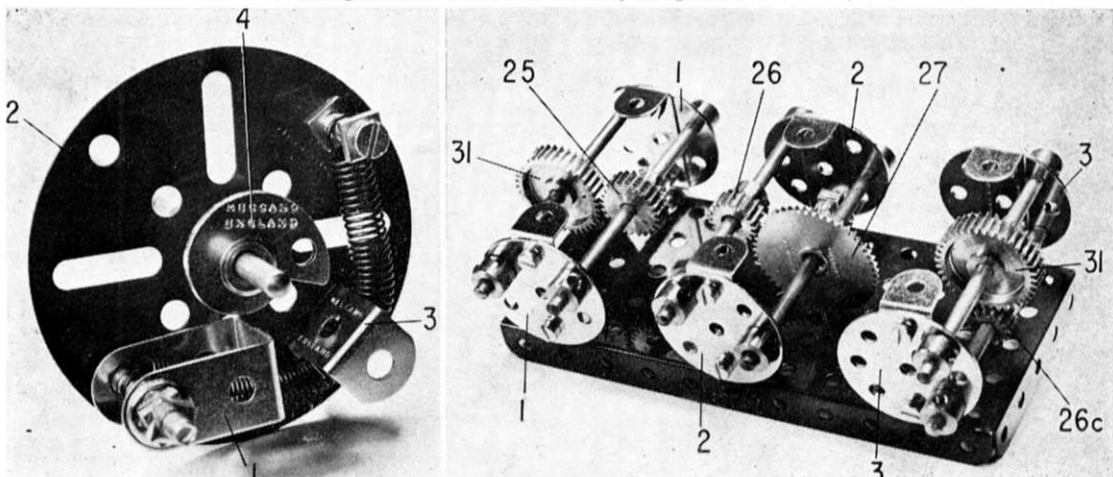



## Potatoes yield to Robot Diggers

**B**EFORE the 16th century it seems our basic diet consisted of bread, beef and beer! Potatoes were unheard of until that time, when they were introduced by the Spanish who had themselves only recently discovered the potato in their conquests of areas of South America.

The ease with which potatoes can be grown soon made them become a major food item. We came to depend on the potato so much for our food that in the years 1845-1847, when the crop succumbed widely to blight infection, the population starved in the period known as the Great Potato Famine.

If potatoes are more than a food, more a way of life, for us, they are certainly a way of life for the farmers of this country. Farmers grow potatoes under the control of the Potato Marketing Board to prevent wide price fluctuations and market shortages of this most important basic food.

Potatoes can be grown in almost any garden with just a digging fork, but to get large quantities to the shops at the very reasonable prices that they are (only half the price of bread, or less) means that farmers must mechanise the job of growing at every stage. Modern wage levels for farm workers depend on high production for each hour of their time. Naturally in this modern age of tractors there are many specialised implements designed to take the back-ache out of the job. I will try and explain some of the typical machines used and the way they are used in a programme which will help to ensure a profitable crop for a grower.

Potatoes are grown in 'ridges'. This means that the potato lies in the centre of a heaped-up mound of earth.

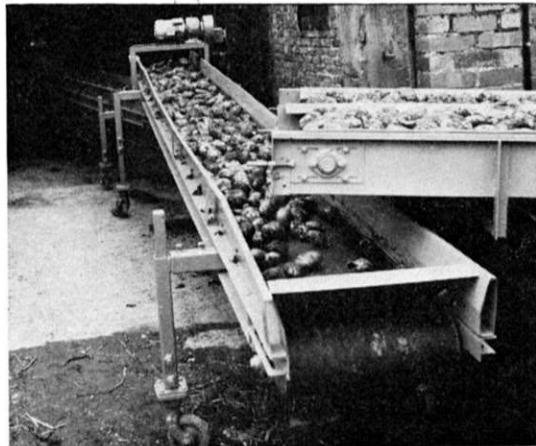

**The story of the humble "spud", a vital element in the world's food supplies. By Richard Lee.**

In a quaint sense they could be considered to be growing 'above ground level'. In this way the tubers can absorb the greatest nourishment and swell to yield the maximum crop tonnages. Good crops yield from 12 tons to the acre to exceptional bumper yields of nearly 20 tons.

The first type of machine that is required, therefore, is one which will cultivate the ground in such a way as to leave the ridges of earth heaped up in rows all across the field. Sometimes this is achieved by drawing a ridging mouldboard through the ground, sometimes by using a powered tool which cultivates the soil and throws it up into the ridges as it passes.

The next operation is to sow the 'seed' potatoes in the open furrows that lie between the ridges. This can be done by hand, simply dropping the potatoes one at a time from a bucket. But for speed and efficiency quite a simple machine enables the men to ride behind a tractor, putting potatoes from the hopper into dropping cups for sowing. As the tractor travels along slowly it also draws a set of ridging mouldboards which are set 'one space over' to *spl*it the ridges back. In this way the potatoes are covered by the two halves of the ridges at the side being thrown together to form a new ridge right on top of the planted potato. Artificial manure can also be fed by placement spouts exactly where the seed potatoes can make the most use of it.

I have used the term 'seed' potatoes because it is the word that is used by farmers and gardeners alike. Botanically speaking, however, potatoes are not grown in this way from true seed. A potato is a tuber which will produce daughter or sister tubers. In turn they will produce more which are all biologically exactly like themselves. This is a vegetative method of plant reproduction something like the way that cuttings from a bush may take root if they are simply broken off and pushed into soil. Potatoes do produce a flower and grow true seeds on the plant. If these seeds are planted they produce many different types of potato from the same parent plant—in the same way that apple pips will produce all sorts of apple trees bearing fruit quite different from the original apple!

The only people who grow potatoes from true seed, therefore, are scientists who are working to discover new

Above left, a typical sprayer with tank and boom mounted on the rear of a tractor.

Above right, a Johnson planter carries two operators who place the seed potatoes into the dropping cups. Fertiliser is fed by placement spouts to lie close to the planted seed and closing discs split the ridge back to cover the potatoes as they are sown—three jobs in one operation.

Left, in the barn the potatoes are sorted into 'ware', 'seed' and 'chat' potatoes. Conveyor belts carry them to bagging-off points.

**A fine team of robot diggers.** The potatoes are lifted, dried, cleaned of dirt tare and loaded into a trailer entirely by machine—and untouched by hand.

varieties of potatoes. This research is very important as certain varieties can be found which are resistant to various diseases and virus infections. New strains that will give higher yields are always being sought, as are potatoes with improved qualities of size, keeping qualities, better flavour and so on. Potatoes with shallow eyes are preferred to those with deep set eyes. This is because deep-set eyes involve more waste on peeling! There is a great deal of scientific research behind our potato!

When the potato plants emerge, the foliage which grows above ground gives an expert a good idea as to the state of progress below ground. A healthy plant is most important if the underground tubules are to spread and swell from the seed potato into a heavy crop. In many areas it is necessary to spray the foliage with blight combating chemicals. Sometimes three or four sprayings are necessary to keep the crop protected from infection. To do this spraying work, the tractor is equipped with a spray tank and boom which delivers the chemical sprays from nozzles along its length. Perhaps twenty rows will be treated simultaneously with just one machine. Before driving into the crop to spray, however, the driver will have to see that the tractor wheels are spaced to run accurately in the open furrows between the ridges—or he would squash down and ruin a whole row of potato plants each time he crossed the field. The wheels of all tractors are adjustable to cover a range of track widths for this kind of reason. The adjustment is made by altering or reversing the 'dished' wheel centres to front and rear wheels alike.

In due course the grower will be satisfied that the maximum growth has taken place and he will soon have to harvest the crop. Sometimes this decision is forced upon him by the arrival of blight conditions which are too severe to combat. Nobody wants the potato tops or 'haulms' which are only a nuisance to harvesting operations once they have started. A common way of removing the potato haulms is to spray the field with a weak sulphuric acid solution. This kills off the plant tops and also the blight virus of an infected crop—preventing the blight from travelling down the stems to the potatoes lying below the surface. The plants wither away quickly and leave the field clear to commence the potato lifting sequence of operations.

There are almost as many different machines for lifting potatoes as there are potato varieties. Some lift the potatoes onto a sorting conveyor belt where operators stand by to pick off the rubbish, the graded potatoes being bagged up in one ground-to-bag operation. Other systems get the potatoes harvested by a two-stage operation. This is usually the most favoured method, although it seems at a first glance to be the least efficient.

The potato digging machine follows the tractor and lifts one or two rows of ridges at a time. The share blade cuts into the ridge at its base and lifts both earth and potato crop onto a wire bar conveyor. This allows most of the earth and rubbish to fall through the bars. The potatoes then fall off the back of the machine to lie across the field in neat rows above the ground, and of course have still to be picked up again.

While they are lying there, however, they are drying out. Everybody knows that soil is always damp and even sticky under the surface. After the potatoes have had a few hours of drying sun and wind on them, the skins will have dried and any adhering mud will tend to

**A Ransome Rotoridger prepares the first ridges in the field prior to sowing potatoes.**



fall off very easily as dust or cracked earth lumps. In this way, when a second lifter—perhaps equipped with an elevator to offload the potatoes straight into a trailer—comes along they will have less dirt 'tare' to be discounted in the gross weight price. Nobody gets paid for handling earth to the greengrocer. Also the dry potatoes will store far better than if they were filled into bags in a damp and sticky condition.

A very sophisticated potato lifting outfit might use three tractors drawing two-row lifters. Lifting six rows, the centre lifter deposits the crop to the rear while the other two lifters have a side-dropping accessory to add their lifted crop to the centre row. Two other tractors following in due course could lift the line of produce amalgamated from six ridges, and load it straight into a trailer travelling alongside. Such a team would harvest thirty or forty tons of potatoes in a day—untouched by hand.

This isn't quite the end of the potato story. Before potatoes can be sold in the shops they have to be graded for size, to remove all the small ones. This is done by passing them over screens with a standard mesh size. In this way the Potato Marketing Board can regulate supplies that arrive on the market according to scarcity, because they announce the mesh sizes over which potatoes must pass before going for sale. If potatoes threaten to be in short supply they will permit a smaller size to be sold.

The small potatoes are known as 'seed' potatoes as they may be suitable for sowing for next year's crop. This depends on the area, disease factors and whether the original crop was itself of good 'seed' quality. Potatoes for human consumption are called the 'ware' potatoes. Any of the small potatoes which are not useful for seed

*(Continued on page 250)*





**W**ITHOUT asbestos it would have been more difficult, perhaps impossible, for man to reach the moon. Vital components of the Apollo spacecraft were insulated with asbestos against the harsh extremes of temperature encountered in space travel. An asbestos-based material is also used for heat-resistance purposes on the rockets and in the venturi tubes, fins and nose cones of guided missiles.

But asbestos is no modern discovery. It was being used by the Finns in 2,500 B.C., added to their lightly fired, thin sided pottery to make it stronger. The ancient Romans used asbestos from the Alps to make cloths in which their emperors were wrapped for cremation in order to preserve the ashes. The Greeks in 438 B.C. used the mineral to mix with vegetable fibres to make longer-lasting lamp wicks. In 28 B.C. its

There are very few aspects of your daily life which are not touched by the remarkable

**“Magic Mineral”**

# ASBESTOS

By A. P. Major

*All photographs by courtesy of Messrs. Turner and Newall Ltd. o Manchester.*

acoustic insulation properties were known when a Greek doctor, later banished for practising “magics”, wrote that if linen made from asbestos was wrapped around a tree the latter could be felled by an axe without a sound being heard.

One of its earliest uses showing its resistance to burning was demonstrated by Emperor Charlemagne of France who threw a table cloth almost certainly made of asbestos into a fire and retrieved it from the flames undamaged. This was done apparently to prove that Charlemagne had supernatural powers! In 1250 Marco Polo, the Venetian explorer, was shown an unburnable cloth made from a “strange woolly fossil substance called salamander digged from the ground”. Until the 17th century, however, asbestos was regarded as a “magical” curiosity associated with superstitious



Heading, this man, protected by his aluminised asbestos suit, walks unscathed through flames at a temperature of 1,500°C. Asbestos suits are used all over the world at motor-race circuits, airports, and other places with high fire hazard.

Far left, drilling in heading 700 ft. below ground in an Asbestos Mine; this is Thetford Mines, Quebec, Canada.

Left, here, a butterfly valve in a power-station cooling system pivots on bearings made from asbestos-reinforced plastic. English Electric Co. Ltd. are suppliers in this case.



An underground gallery in an Asbestos Mine, showing the use of yieldable arches replacing the solid beam type of roof support.

beliefs. Little use was made of it from then, even after it was discovered in Canada in 1847, until 1878 when mining asbestos started at Thetford, Quebec. Its principal use at that time was not as a fire resister but for lagging to conserve heat. Similarly, in 1803 blue asbestos had been found by a German geologist in the Orange River Valley, South Africa, but serious exploration of it did not start until 1891.

The word asbestos is Greek. "A" is the negative and "bestos" is the adjective from the verb "sbennum", meaning to quench, die down, extinguish, but this in reality contradicts its important characteristics of being incombustible and also resisting the effects of friction and corrosion.

Asbestos is a mineral rock found in seams or layers between varying thicknesses of other rock and is mined in the same way as iron or copper. It is fibrous in composition and as the fibres are pulled away more fibres are revealed, which can be sub-divided several times. There are various grades of fibres, some of the finest being between one millionth and one ten-millionth of an inch in diameter. There are many types of asbestos, the most widely used being chrysotile, other main types being amosite, crocidolite, actinolite and anthophyllite, some of these having specialised uses. The larger chrysotile fibres are best suited for weaving into asbestos textiles. The asbestos-bearing strata may be near the surface, so it can be obtained by open-cast mining, or the mine workings may be open with horizontal tunnels driven into the rock face and the rock brought out in tubs or on a conveyor. If at a considerable depth, then shafts have to be sunk so the asbestos can be mined like coal.

After reaching the surface it is sorted from the unusable rock. It is then taken to a mill where it is easily broken down when crushed, then screened so the fibres are separated and cleaned, graded and bagged.

Asbestos next goes through various other processes depending on its intended use. The graded fibre is crushed between granite rollers, but this must be skilfully done otherwise too much crushing ruins the fibre. Following this the asbestos fibre is "opened" or fiberised, being passed through a high speed machine where it is rotated and beaten, then collected and bagged for despatch to the manufacturing firm. If the fibre is to be used for textile production the fibres are now passed

**Drilling the rivet holes in a brake lining in one operation on a special machine at a Ferodo factory; Ferodo Ltd. is a Turner and Newall company.**



The stock area for asbestos-cement pressure pipes and pipes for sewerage and drainage in the Ditton (Lancs.) factory of TAC Construction Materials Ltd.

through a vibrating screen which eliminates the unopened, shorter and uneven strands of fibre. The fibres are then combed on carding machines from which continuous ribbons of fibre are rubbed into slivers, which look like loose string. These are next collected on large bobbins ready for spinning, the latter strengthening the asbestos by imparting twist. Weaving is carried out on normal looms to produce cloth of many varieties of style, texture and thickness. It is used for fireproof and insulating clothing, insulating mattresses for boilers and locomotives, fire blankets to smother fire outbreaks, and safety curtains in cinemas and theatres. Ironing rollers in laundries are covered with asbestos cloth because damp and heat do not affect it. Asbestos insulation tape is used in electric motors to protect vital parts from overheating, and as seals and jointings in automotive, aircraft, shipbuilding, chemical, oil and petrochemical industries. The heating systems and jet pipes of the turbine engines of the hovercraft are lagged with asbestos material. Asbestos is used in almost all motor vehicles in disc-brake pads, drum brake linings, clutch

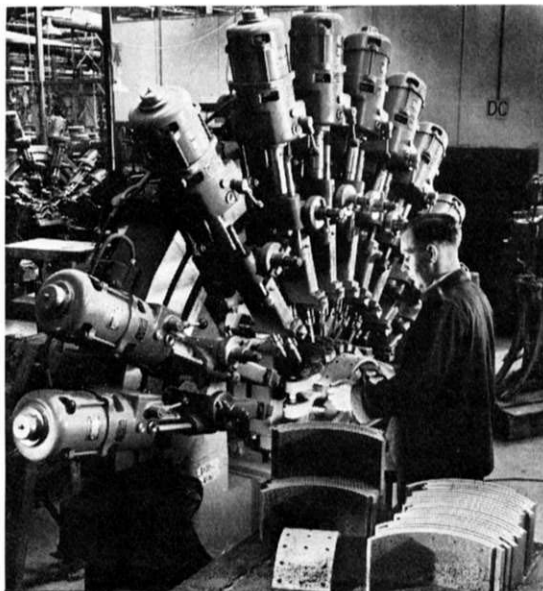

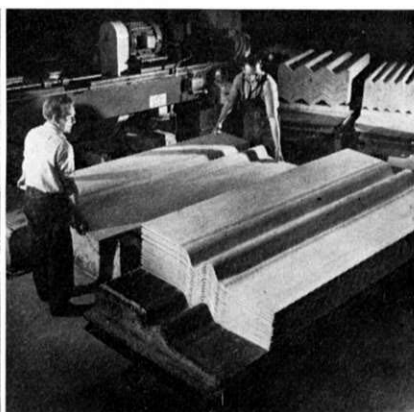
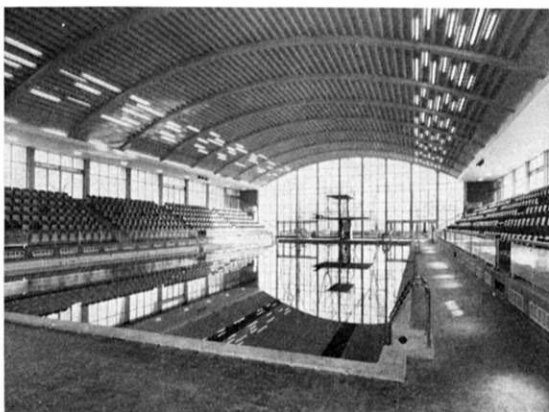

Left, shows two operatives using a high powered mechanical saw to trim "Turnall" Cavity Decking Sheets to the exact dimensions required.

Far left, the roof of this swimming pool has been treated with sprayed "Limpet" Asbestos for acoustic control.

facings, for carburettor insulators, in gaskets and heat shields, sealing fuel pipes and exhaust systems. In ships, cabin walls, ceilings and partitions have asbestos insulation board, asbestos also being used to insulate boilers, pipes and steel deckheads.

Asbestos cloth, after being aluminised to give it a heat-reflecting surface, is made into suits for fire-fighters at motor racing tracks, oil refineries, and airports, also for steel and similar workers needing protection against heat and sparks.

But asbestos has many other uses. The short fibres are used to manufacture asbestos boards and moulded

articles. Asbestos-cement, a combination of fibres with a cement, makes a very strong inexpensive fire and corrosion resistant material. It is used as fabrication for roof and wall cladding and insulation partitions and ceilings. When moulded it can be used for various types of pipe, cable conduits, troughs, cisterns, water tanks, floor tiles, slates.

In recent years another way of using asbestos has been to spray the fibres on to structural steelwork, also to the underside of floors of buildings, where a fire hazard exists. When the Building Research Station carried out a test to determine the efficiency of sprayed fire insulation it was discovered that a floor sprayed with one inch of asbestos on the soffit withstood a mean temperature of 1000° C for four hours without damage, but a similar floor tested with half an inch of plaster instead of asbestos failed completely after 25 minutes of fire exposure. The asbestos fibre is applied by a special spray gun which mixes the fibre and binding agents with a fine spray of water and enables the fibre to be built up layer by layer. This process can also be used to prevent condensation and reduce noise and improve the acoustics of buildings, churches, lecture halls, etc.

Asbestos fibres are also widely incorporated into other materials required to withstand tough operating conditions. They are added to rubber, ceramics, plastics, and metals. The window frames of the Concorde are made from asbestos-reinforced plastic, so are aircraft fuel tanks and nuclear power station components. Asbestos fibre is used to reinforce thermoplastics for such widely varying items as road signs, floor tiles, light bulb holders and vehicle battery boxes. Resinated asbestos is used for underwater bearings in rudders, propeller shafts and stabilisers.

The chief deposits of asbestos are in Canada, South Africa, and Russia, although there are other areas in China, Rhodesia, Australia and Bolivia, but new sources are continually being sought, to meet increasing demand. New developments in colour finishes and surface textures in asbestos-cement, for example, have broadened its use by designers and architects, and research is still continuing into finding more outlets for asbestos.

The author gratefully acknowledges the assistance of the Asbestos Information Committee, Turner & Newall Ltd., Manchester, and the Cape Asbestos Co. Ltd., London, for information and illustrations used in the preparation of this article.

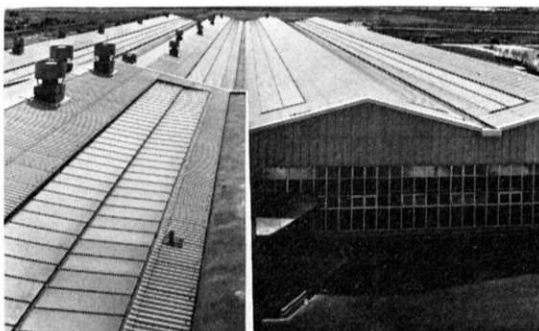

Above left, a view over the roof of the Ditton factory, showing the use of asbestos-cement corrugated sheets, and asbestos-cement extractors.

Left, weaving asbestos cloth on a Northrop Loom at TBA's Rochdale factory, largest asbestos textile factory in the world.



# Catapult Gliders

Three simple and inexpensive fun models designed for you  
by Stephen Archibald

MODEL aircraft do not have to be complicated and tricky to make and fly; an enormous amount of fun can be had from something very simple and cheap to make, such as these snappy little catapult gliders. You can even have competitions with them, shooting two or more off simultaneously with the winner obviously being the last one to land. Or you can fit little paper trim tabs (or warp the flying surfaces by breathing on them) to make quite remarkable aerobatic machines; as an example, a tiny amount of warp in one wingtip of the Gnat will produce an exhilarating series of upward climbing rolls, gradually slowing until the model's speed allows it to resume a normal flight path.

"Combat" is another possibility, an interceptor model being catapulted at a model already gliding—or at least, where you think it will be by the time the interceptor gets there. If the models do collide, chances of damage are very slight due to their light weight, and in any event repairs are very simple.

The only materials needed to build several such models are a sheet each of  $\frac{1}{8}$  in. and  $\frac{1}{16}$  in. balsa, medium hard (or a balsa pack containing these thicknesses), a tube of balsa cement, a tiny amount of sheet lead, and a modelling knife, though if you want to make a really good job, you will also need sanding sealer, glasspaper, and colour dope or paint.

The construction is quick and easy and in no time a whole squadron of Messerschmitts and Spitfires or a formation of Red Arrows can be built. The wings can be traced down on to the  $\frac{1}{16}$  in. balsa either by using carbon paper or by pricking round the lines with a pin, so leaving pin holes in the balsa which can be joined up with a soft pencil.

The fuselage is traced and then cut out using the same method on  $\frac{1}{8}$  in. balsa. The slots for the wings have to be very carefully cut out, making sure they are not cut oversize, otherwise the wings will keep falling out. The wings can of course be glued, but are best left as a slide fit, so that replacements can be fitted if some part of the aircraft should break.

The amount of lead needed on the nose is very small and will vary slightly with each model. The models in the pictures used sheet lead under  $\frac{1}{16}$  in. thick and needed a strip about  $\frac{1}{4}$  in.  $\times$   $\frac{1}{2}$  in. folded in the centre and squeezed onto the fuselage as drawn. When finally adjusted for smooth flight, it is worth covering the edges of the lead with a film of cement to prevent losing it.

Decorating and painting the models is not essential but it does make them look a bit more realistic. The Spitfire was finished in dark green and dark earth, with duck egg blue undersides and fuselage band. All of these colours are available in the Humbrol range. The markings are from a box of old spare transfers as are the markings on the other two aircraft.

The Messerschmitt 109E was finished in two shades of green and pale blue, the lighter shade of green being the same as used on the Spitfire and the darker shade being

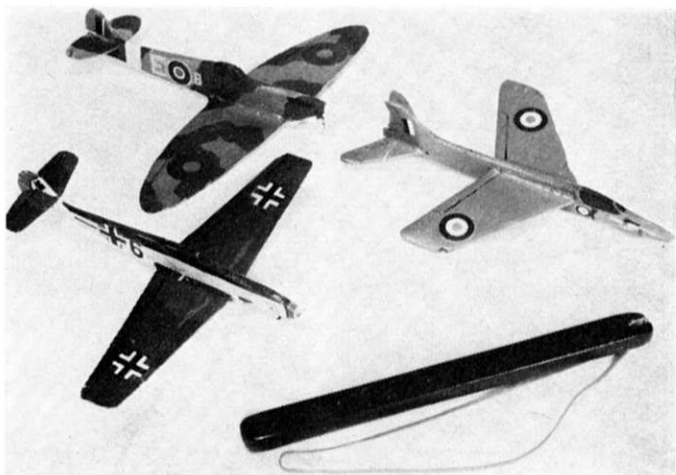

the same paint with a little matt black added. The pale blue for the undersides is made from four parts white and one of blue. The spinner, number and rudder should be painted red, white or yellow. As you can see our model has a black number, which is due to the fact that we couldn't find the correct colour number in the transfer box. The Red Arrows Gnat was painted Humbrol gloss red all over with a white lightning flash.

The hand catapult, shown in the photograph, is simply made from a length of wood roughly  $\frac{1}{2}$  in.  $\times$   $\frac{1}{2}$  in.  $\times$  6 in. with a hole drilled at one end and a groove cut in the end and a rubber band threaded through and tied as per the diagram. With some amount of practice the gliders can be made to perform various stunts using this method. The other method is to use a 20-25 foot length of  $\frac{1}{8}$  in. flat rubber which has a wire ring tied to one end and the other tied to a peg in the ground. This method, although the best for height and long flights, can be dangerous and care must be taken to ensure that no one is in front of the catapult at the time of releasing—the model will be travelling at over 100 m.p.h.!

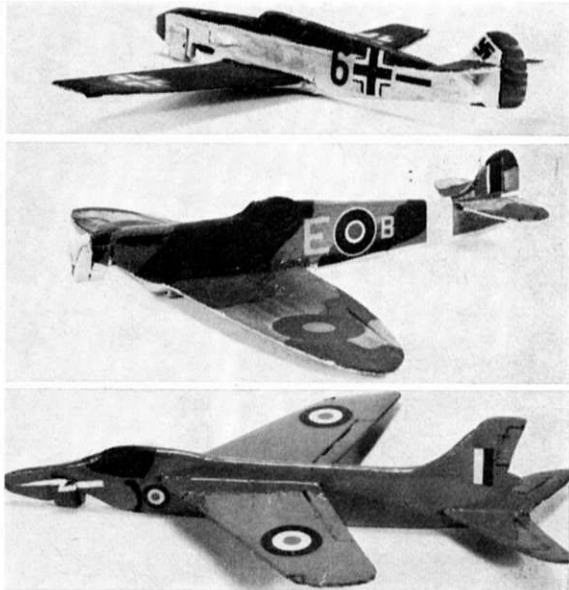

## Messerschmitt BF 109E

1/16" Balsa

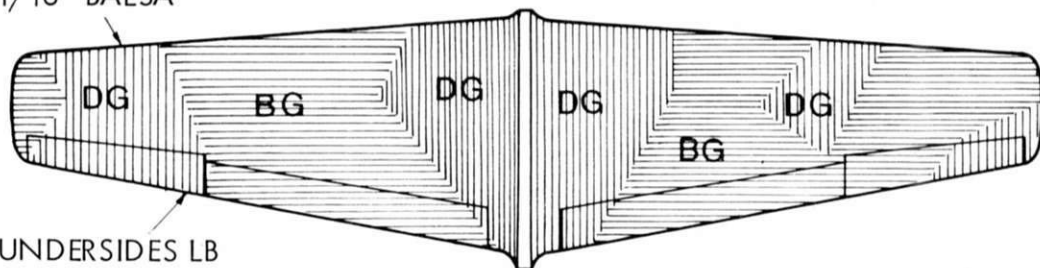

UNDERSIDES LB

RUDDER, NUMBER AND SPINNER  
RED, WHITE OR YELLOW

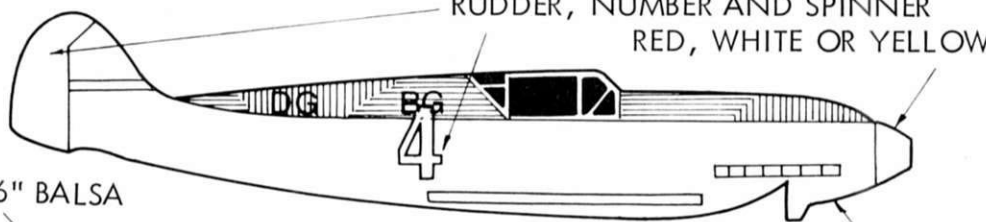

1/16" Balsa



1/8" Balsa

## Supermarine Spitfire Mk I

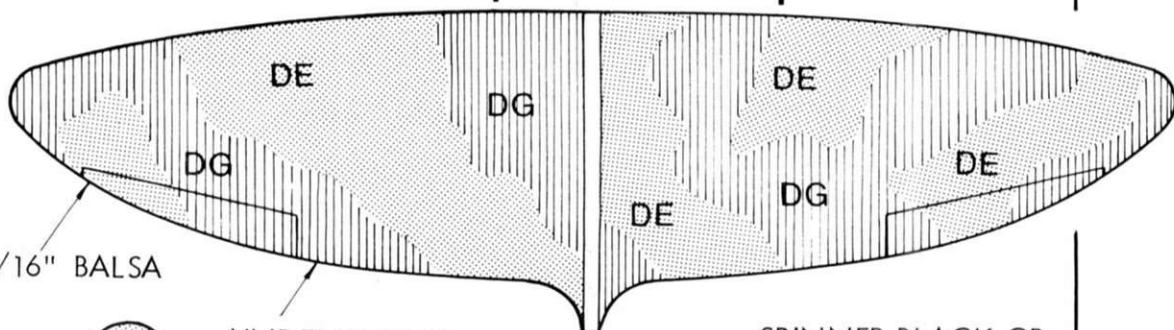

1/16" Balsa

UNDERSIDES DB

SPINNER BLACK OR  
DUCK-EGG BLUE

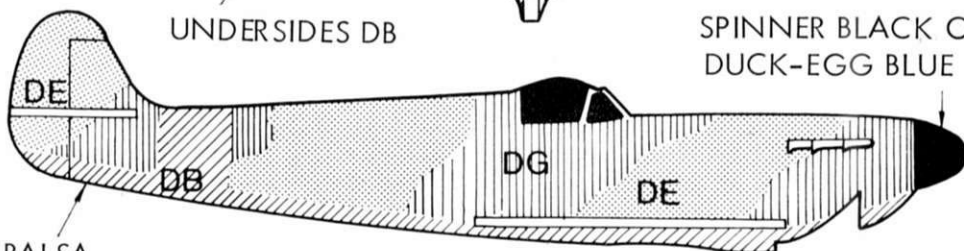

1/8" Balsa

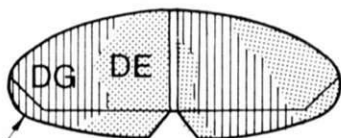

1/16" Balsa

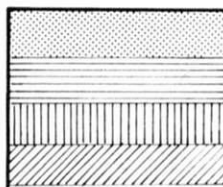

DE DARK EARTH  
BG BLACK GREEN  
DG DARK GREEN  
DB DUCK-EGG BLUE  
LB LIGHT BLUE

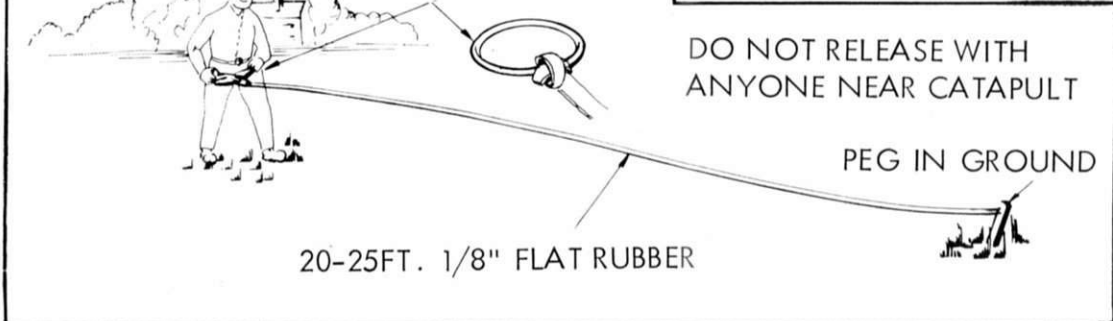
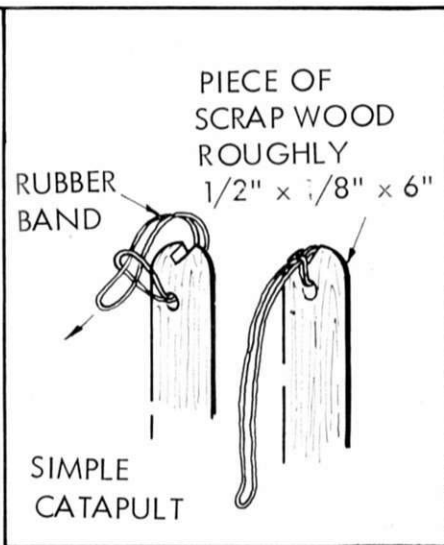
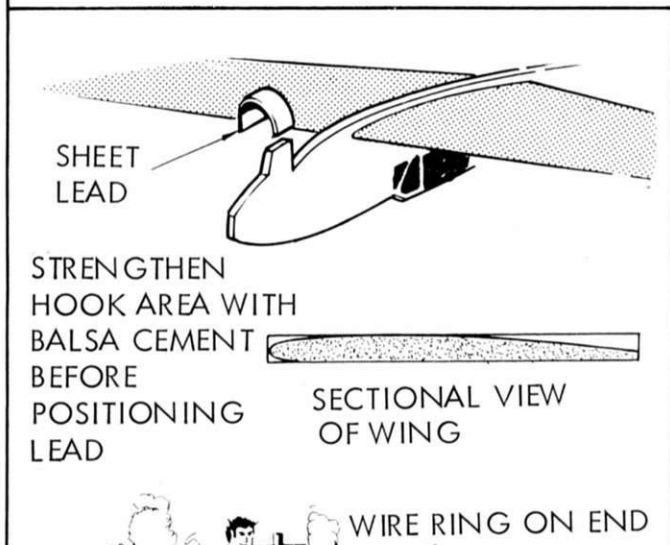
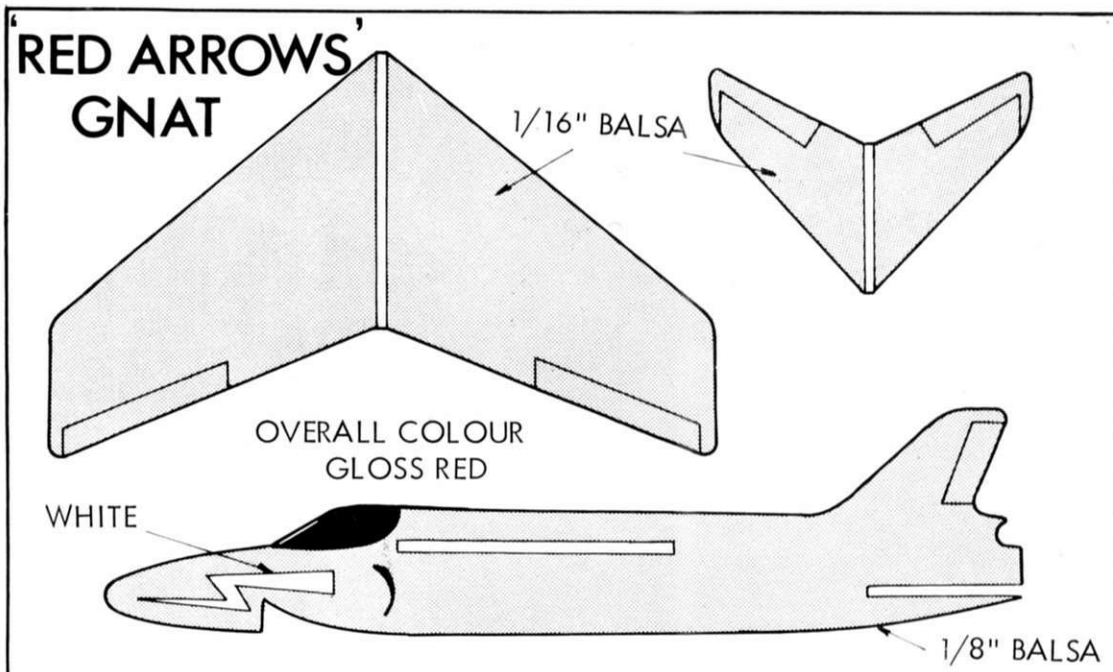

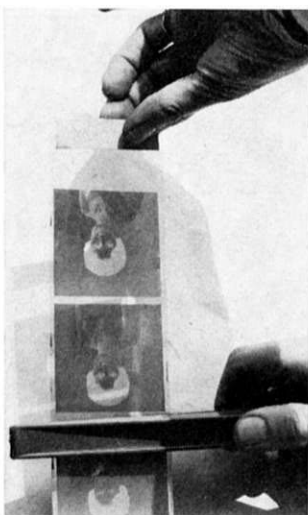
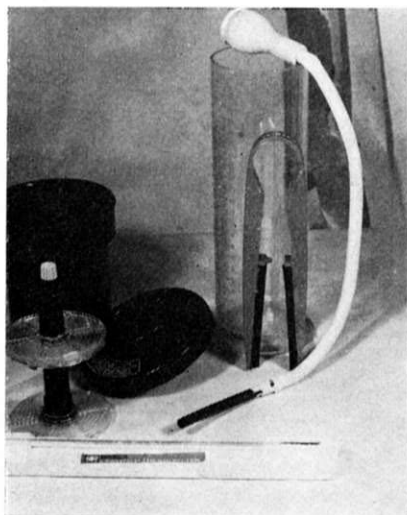

## PHOTOGRAPHY IS EASY NUMBER SEVEN

# Try Developing Your Own

By Peter Wilkes

TO obtain the ultimate satisfaction from any hobby it is essential to take part in the full chain of events that leads to the finished product, and photography is no exception. Yet many camera users, once the mechanics of picture making in the camera are completed, are only too ready to take the film to the nearest chemist with a request that it be developed and printed.

This is a great pity, for the thrill of developing your first film is one of the great and, in many cases, lasting impressions of the amateur photographer. The feeling of satisfaction when that film, still dripping with water, is held to the light and a full strip of negatives can be clearly seen is an experience not easily forgotten.

The process of development is not concealed under vague scientific terms but is, to all intents and purposes, a practical task that is both easy and inexpensive.

Basically what happens during the process, which must of course be carried out in a light tight vessel called a "developing tank", is as follows. The film, when light fell on it in the camera, had the silver halides of its emulsion "burned" by the reflected light from the image being photographed and it is this invisible image, or "latent image" as it is called, that is developed and made visible. This is accomplished by chemicals bought from any photographic dealer in the form of a prepared developer which comes supplied with full instructions for use.

If, for example, a film has been exposed to the bright light from a sky, the silver halides on that part of the film will have been strongly affected by the light and, under the process of development, will blacken. Parts of the film that were influenced by dark objects in the original scene will not have been so affected and, during a stage of the development process called "fixing", will be dissolved away.

From the foregoing it will be seen that the actual developer does only one thing to the film, darken those parts of the film that have been affected by light. It will be obvious that, if the process finished here, when the film was removed from the developing tank and exposed to light, those parts not affected by light in the original scene would soon darken and all you would have would be a roll of completely black film.

To prevent this happening, development is followed by a process called "fixing" and only after this can the film be inspected in the light. The "fixer" removes

from the film the unexposed silver halides in the emulsion—those silver halides which, because they represent the dark part of the original subject, have no light action on them from the original scene.

The requirements for the home development of a film are as follows:

1. A developing tank for the size of film used in your particular camera.
2. Thermometer.
3. Three plastic measures holding—
4. Chemicals in the form of developer, a stop bath and fixer.

The developing tank is, basically, a light tight container with a reel on to which the film is wound. The lid has a light-trapped hole through which chemicals may be poured into and out of the tank. In this hole is also fitted a rod with which the reel can be turned during development. Obviously the film must be threaded on to the reel and the reel put into the tank in darkness, but in practice such a place is not difficult to find. A small cupboard with a blanket covering the door to block out the light will be adequate for loading a developing tank.

For the first attempt it is recommended that a trial loading is done in daylight. The seal on the film, if say a 120 or 620 size, is first broken and then the backing paper unrolled until the actual film surface is felt. The edges are then fed into the spirals after which the ratchet action of the spool as the top and bottom halves are rotated will feed the film automatically. With a 35 mm film, there is no backing paper and the film is fed directly into the tank from the cassette after the tapered film lead has been cut off.

Developing is carried out on a time-temperature method. Tables supplied with the developer give the times that each film has to be developed at a temperature specified in the tables. As an example, the concentrated developer "Acutol" is diluted 1 to 10 and an F.P.4 film is developed in that solution for 7½ minutes.

The developer, if it is a concentrated solution contained in a bottle, is diluted according to instructions, or, if it is a powder, mixed in accordance with the instructions, and then poured into the tank. After the development period is up the developer is poured away and a stop bath used on the film. This neutralizes the still active developer carried in the emulsion.

A practical stop bath can be made up from a solution

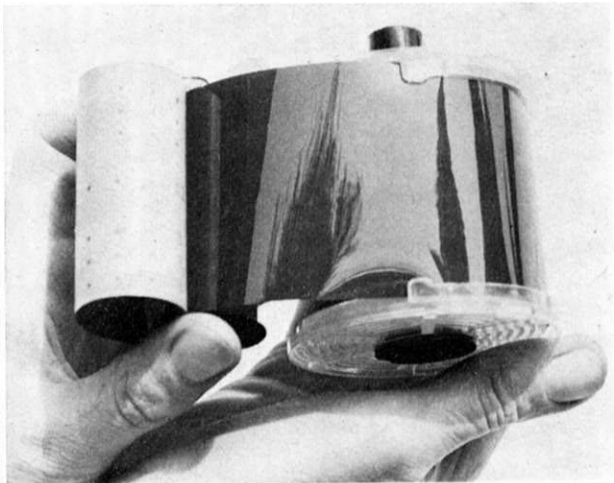
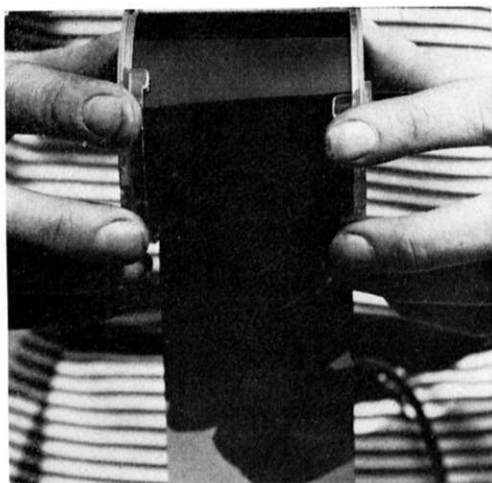

Photographs from left to right show: 1. The requirements for developing a film. (A) Tank; (B) Lid for tank with pouring hole for chemicals in top; (C) Spool on which film is wound; (D) Thermometer; (E) Measure for use when mixing and pouring solutions; (F) Film wash, connects from tap to hole in centre of tank lid and hence through spiral containing film; (G) Wiper for removing water from film before hanging it up to dry. 2. Showing the use of the film wipe to remove water drops from the film before hanging it up to dry. 3. Showing how a film is started into the spool. The backing paper is unrolled until the film is felt. This is then pushed between the opening grooves of the spiral. 4. Showing the automatic load action of the spool. After the film has been started it will wind onto the spool automatically by rotating the two sides.

of 80% acetic acid, with half an ounce of this added to 20 oz. of water. Such a solution will, when made up, serve for up to six films before it has to be discarded.

After the stop bath, the fixer, which again will be either a concentrated solution in a bottle or a powder to be mixed with water, is poured into the tank for a time as given on the instructions. When the time is up for the fixer all that remains is for the film to be washed in running water and then hung up in a dust free place to dry.

The process of development can be outlined by the following steps:

1. Wind film on spool—put spool in tank.
2. Pour the three required chemicals, developer, stop bath and fixer, into three plastic measures. Dilute as per instructions at a temperature of 68 degrees F.
3. Hold the tank in one hand, slightly tilted to avoid airlocks and pour in the developer with a steady flowing action.
4. Start timing as soon as developer is in. A special timer can be bought but a watch with a second hand will perform equally well.
5. Agitate the film for ten seconds every minute. This can be done either by rotating the spool backwards and forwards with the rod which fits through the hole in the tank top or, if the top can be fitted with a

plastic cover, by inverting the tank upside down and back again twice each minute.

6. Pour out the developer so that the tank is empty just as the development time is up.
7. Pour in stop bath—agitate film—pour out after one minute.
8. Pour in fixer. Agitate film—pour out at a time as given on fixer instructions.
9. Wash film. For a few pence a specially prepared "hose" which fits over a tap and into the hole in the tank lid can be bought. Ten minutes under the tap with this system is sufficient for any film.
10. Wipe film with a film wiper. Again an accessory that costs only a few pence but which, through the wiping action of its rubber blades, takes all the excess water from the film and hence any drying marks caused by blobs of water being left on the film.
11. Hang film up to dry in dust proof place—an airing cupboard is ideal if the doors are kept closed.

Although there are various types of developer and fixer on the market, the beginner developing his first films would be advised to use, for simplicity's sake, one of the excellent bottled concentrated types that only require diluting with water before use. Any photographic dealer will be happy to suggest a suitable type for the film you normally use.

## HAVE YOU SEEN?

## Recent books received for review

THE 21st Observer's Book of Aircraft contains descriptions, photos and silhouettes of all the aircraft that will (or are expected to) fly in 1972. The book has nearly 300 pages and includes every aircraft, civil and military, plus a section at the back devoted to helicopters. This book is exceptionally good value for 45p.

Another invaluable book, this time for warship enthusiasts, is the latest Almark Publication "German Navy Warships 1939-1945" by W. D. G. Blundell. It contains 1/1200 scale line drawings together with a selection of photographs of the German fighting fleet of World War II. All the ships are shown in class order and cover everything from the battleships *Bismarck* and

*Tirpitz* to Mine Transporters. There is an introductory text outlining the functions, activities and development of each type of warship, together with class lists and basic specifications. The book can either be purchased case-bound at £1.90, or as a paperback at £1.25.

"War Games Through the Ages" is not, as it may seem from the title, a history of war gaming but, in fact, an informational book on the real armies. It covers the period 3,000 B.C. to 1,500 A.D. giving data on the history and fighting abilities of all the major armies during this time. The book, written by Donald F. Featherstone, retails at £2.75 in the U.K.

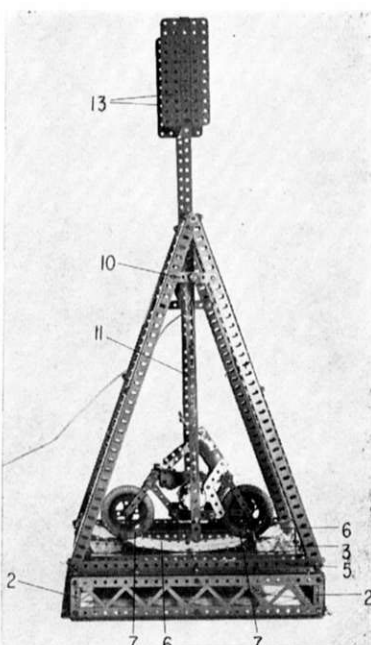
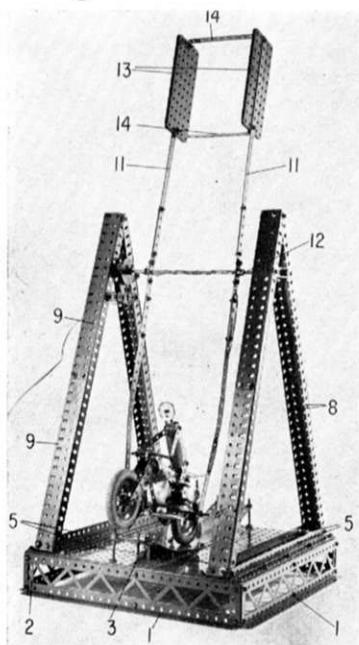

WHEN I was first presented with the model featured in this article, I was puzzled. I could see it was some sort of motor-cycle. But, at first glance it seemed to have an exceedingly large framework for such a small—if realistic—presentation. At this stage, the motor-cycle was locked in position and consequently didn't appear to do anything in particular. I must admit I then made the classic mistake of pre-judging the model before having it explained to me: I was unimpressed—which just goes to show how wrong you can be! In due course, our builder released, not the motor-cycle, but the counter-weighted arm on which it was mounted, coupled up a power unit and proceeded to give me a working demonstration of one of the most appealing "fun" models I have seen for a long time. In very short order, he had me utterly captivated by the sight of his Centrifugal Motor-cyclist, as he called it, whirling round in a spinning vertical circle, controlled by a few skilful "bursts" on his power unit throttle. "A must for the Mag.," I thought, and now here it is!

#### Framework

Needless to say, with the spinning motorbike feature of this model, a really strong and rigid framework is required to carry it. A fairly heavy base is therefore built up from four  $12\frac{1}{2}$  in. Angle Girders 1, arranged in a square and connected

together by being bolted to four vertical corner posts 2, supplied by 2 in. Angle Girders, the securing Bolts helping to hold four  $12\frac{1}{2}$  in. Braced Girders in position, as shown.

Another square, built up from four  $12\frac{1}{2}$  in. Angle Girders, is bolted to the top of the corner posts, the Braced Girders also being secured to this, then the whole top of the base frame is covered in by eight  $5\frac{1}{2} \times 3\frac{1}{2}$  in. Flat Plates and three  $5\frac{1}{2} \times 2\frac{1}{2}$  in. Flat Plates 3, all overlapping each other as required, with the smaller Plates 3 running in a centre strip from one side of the upper square to the other. Note that the ends of this "strip" are attached to the Girders, not by Bolts, but by 2 in. Screwed Rods 4, held in the Plates by Nuts, and note, too, that some of the other Plate fixing Bolts also hold four additional  $12\frac{1}{2}$  in. Angle Girders 5 in position, these being arranged in two pairs of two at parallel edges of the frame, with the Girders in each pair separated by a distance of three clear holes.

Secured by Nuts and Washers between the upper ends of Screwed Rods 4 at each side is a  $12\frac{1}{2} \times 2\frac{1}{2}$  in. Strip Plate 6. Taking full advantage of its slotted holes, this Plate is carefully curved so that its centre touches the Flat Plates, to which it is bolted, the curve being held between the centre and the ends by lock-nuts on  $1\frac{1}{2}$  in. Bolts 7 passed up through the Flat Plates

## CENTRIFUGAL MOTOR CYCLIST

"A thoroughly enjoyable  
fun-piece" says Spanner

Spanner thinks that this is one of the most appealing "fun" models he's seen for a long time. The two views on the left give a hint of its function. Note the curved shape of Strip Plate 6.

and through the sixth holes from each end of the Strip Plate. Adjustment of Strip Plate height and curvature may be necessary at a later stage.

Two triangular mountings for the motor-cycle arm are next each built up from two compound channel girders each consisting of two  $18\frac{1}{2}$  in. Angle Girders 8 connected together to form the channel by two  $9\frac{1}{2}$  in. Flat Girders 9, using the circular-hole flanges of the Angle Girders. The upper ends of the channel girders are simply bolted together, while their lower ends are secured to the ends of Angle Girders 5 on the base. Bolted between the flanges of each pair of channel girders, seven holes from the top, are two  $2\frac{1}{2}$  in. Strips 10 which will later provide the bearings for the revolving arm pivot.

#### Revolving Arm

The revolving arm, itself, is produced from two 27 in. compound strips 11, each built up from a centre  $7\frac{1}{2}$  in. Strip extended 19 holes upward by a  $12\frac{1}{2}$  in. Strip and 20 holes downwards by another  $12\frac{1}{2}$  in. Strip. (For description purposes, I am regarding the lower end of the arm as that to which the motor-cycle will be fitted.) A Double Arm Crank 12 is bolted to the Centre of each  $7\frac{1}{2}$  in. Strip.

Counterweights to balance the motor-cycle must of course be provided at the upper end of the arm and, on our model, we found that twelve  $4\frac{1}{2} \times 2\frac{1}{2}$  in. Flat Plates 13 worked out splendidly. These are bolted—half each—to strips 11, the securing  $\frac{1}{2}$  in. Bolts also fixing two  $4\frac{1}{2} \times \frac{1}{2}$  in. Double Angle Strips 14 between the Plates.

#### Motor-cycle

Turning, now, to the motor-cycle, this is built up round a

Meccano 3-12 volt Motor with Gearbox, as can be seen from the illustrations. Two Fishplates are first bolted to the top of the moulded base of the Motor, one each side, using the holes nearest the Gearbox end, then a Double Bracket 15 is fixed to the free end of each Fishplate. Secured to the lugs of the forward Double Bracket, not by Bolts, but by Nuts on a 3 in. Screwed Rod 16, are two 2½ in. Narrow Strips 17 angled upwards to serve as part of the frame. Bolted to the end of these Strips are two 3 in. Narrow Strips 18, serving as the front forks, the securing Bolts passing through the second holes of the Strips and also fixing in place between the Strips a Double Bracket 19 with its lugs extended by Fishplates to strengthen the upper part of the fork assembly. The upper ends of these Fishplates and Strips 18 are connected by a Large Fork Piece 20, the securing Bolts in this case also holding two 4½ in. Narrow Strips 21 in position to form the crossbar. The handlebars are simply supplied by a 2½ in. Stepped Curved Strip bolted to the boss of the Fork Piece.

Secured to the lugs of rear Double Bracket 15, again using Nuts on a 3 in. Screwed Rod 22, are four 2½ in. Narrow Strips arranged in two pairs, 23 and 24. Pair 23 project horizontally rearwards, while pair 24 project diagonally upwards, their upper ends being bolted, along with two more 2½ in. Narrow Strips 25, to the rear ends of crossbar Strips 21, the securing Bolts also fixing a Double Bracket between Strips 21. A Flat Trunnion 26 is bolted to the back of this Double Bracket to serve as the seat.

The crossbar Strips are further connected through the fourth holes from the rear by another Double Bracket, while the fuel tank is represented by two 2½ × 1½ in. Triangular Flexible Plates 27, curved to shape and bolted to an Angle Bracket fixed to the crossbar.

The lower end holes in Strips 25 coincide with the end holes in Strips 23 to provide bearings for the rear axle: a 2 in. Rod held in place by Collars outside the Strips and carrying a Collar and a 2 in. Pulley with Motor Tyre between the Strips. A Cone Pulley 28 is fixed on the end of the Rod, the smallest pulley of the Cone being

Right, another view of the motor-cycle and rider, removed from the rotating arm. The realistic proportions have been achieved by the use of Narrow Strips for the motor-cycle frame. Far right, the apex of one of the triangular mounts, showing the Commutator and Wiper Arm used to take power to the motor-cycle.

Above, a close up-view of the motor-cycle as it "climbs" upwards off its track. Below, the realistic features of the motor-cycle show up well in this view of the machine, removed from its rotating arm.

connected by a 6 in. Driving Band to a ½ in. Pulley on the Motor output shaft. The front wheel is supplied by another 2 in. Pulley with Motor Tyre, mounted, along with a Collar, on a 1½ in. Rod, journalled in the end holes of the front fork Strips.

This brings us to the motor-cyclist himself, and construction again is easy. His body consists of two "U"-section Curved Plates 29, bolted together, with two 3 in. Narrow Strips for arms and two 2 in. Strips, bolted together at an angle, for each leg. The head is a 1 in. Pulley without boss 30, fixed to the long lug of a 1 × ½ in. Angle Bracket which is in turn fixed to an ordinary Angle Bracket bolted inside the upper edge of front Curved Plate 29. This latter Angle Bracket is spaced from the Plate by three Washers on the shank of the securing ⅜ in. Bolt. The completed rider is attached by the lower edge of front Plate 29 to an Obtuse Angle Bracket bolted to the apex of Flat Trunnion 26, his arms being secured by short lengths of Cord to the handlebars of the bike.

Fixing points to enable the bike to be attached to the rotating arm are now provided. At the right-hand, or Motor output side of the model, a 2½ in. Strip, overlaid by a 1½ in. Corner Bracket 31, is fixed by Nuts on the ends of Screwed Rods 16 and 22. Note that the Corner Bracket is secured to the centre of the Strip by a ⅜ in. Bolt 32, shank outwards, another similar Bolt 33 being fixed in the lower corner hole of the Bracket.

At the opposite side of the model, a 2½ in. Strip 34 is held by Nuts on the other ends of Screwed Rods 16 and 22, a 2 in. Screwed Rod 35 being fixed by Nuts in the centre

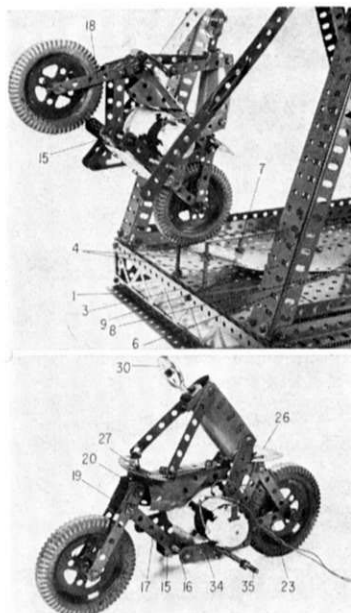

hole of this strip. The lower ends of compound strips 11 of the revolving arm are then curved inwards to the desired shape and the completed motor cycle is then fixed to the arm by locking the strips on Bolts 32 and 33 and Screwed Rod 35, using Nuts in the ordinary way.

With all stationary parts tightly bolted together to ensure rigidity the arm is now mounted in the framework by means of an 11½ in. Rod fixed in Double Arm Cranks 12 and journalled, free, in Strips 10, being held in place by Collars. Also fixed on the Rod is a Flat Commutator 36 (Electrical Part No. 551), in contact with which is a 2 in. Wiper Arm (Electrical Part No. 533). This Wiper is bolted to two 2½ in. Insulating Strips 37 (Electrical Part No. 502), fixed to nearby Angle Girders 8 of the frame through their tenth holes.

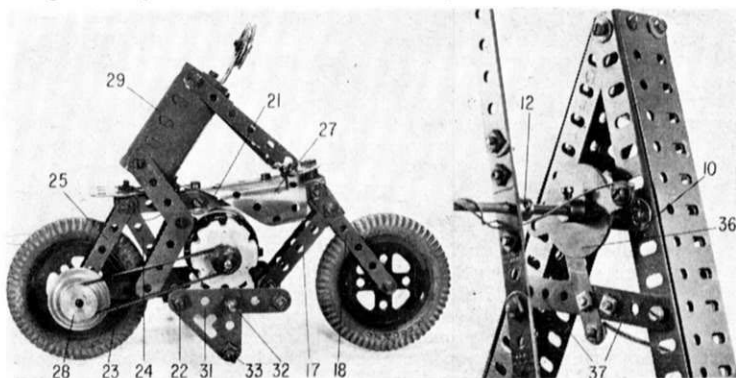

All that now remains to be completed is the wiring. The Motor leads are threaded up nearby strip 11 of the arm and wrapped around the 11½ in. Rod. One lead is then earthed by connecting it to one of the bolts in nearest strip 11, while the other lead is connected to one terminal of Commutator 36. Of the leads from the power source, one is connected to the Wiper Arm engaging with the Commutator, while the other is also earthed by connecting it to the frame.

Provided the model is built from current zinc-plated parts, no electrical circuit problems should arise, but if old enamelled parts are used, care must be taken to ensure that the earthed leads make proper contact with bare metal—even if it means removing some enamel. It would also be necessary to remove the enamel from inside the holes in which the 11½ in. Rod is journalled, otherwise the paint might insulate the Rod from the frame and thus prevent a complete circuit.

### Operating the Model

Once the model has been built, some adjustments may be required before full-scale operation can begin. The revolving arm, for example, must turn freely, with minimum friction, and it should be fairly well-balanced, although perfect balance is not required. In fact, the motor-cycle must be slightly heavier than its counterweight to ensure that, without power, it will return to its track, i.e. to Strip Plate 6. Most important of all, however, the wheels must make contact with the full length of Plate 6, during

operation, and they must do so with just the right amount of pressure—not so lightly that they hardly provide adhesion and yet not so heavily that the friction reduces performance. The height and curvature of the Plate can be altered, as required, by adjusting the fixing Nuts on Screwed Rods 4 and Bolts 7.

Operation itself is not simply a question of switching the motor “on” and watching the model whirl into action. It won’t happen! The motor drives only the motor-cycle, therefore this machine must be skilfully manoeuvred until it gains sufficient momentum to “push” the revolving arm through a complete circle and, once done, to keep it spinning for as long as desired. To achieve this, a reversible power source is required, such as a Meccano Battery Box, or a suitable model railway power control unit. Failing this, a reversing switch in the power feed circuit would serve the same purpose, Model No. E3 in the Meccano 4EL Manual being an example of such a switch.

With everything set up, the driving sequence starts with a burst of forward power to the model. This sends the motor-bike forward, off Plate 6 and into the air, but not, at this stage, high enough to “go over the top”. Power is cut as soon as the bike is clear of the Plate. Because the bike is heavier than its counterweight, it will swing backwards once its forward movement is exhausted. As soon as its back wheel contacts Plate 6—or slight beforehand—reverse power is fed to the model which, of course, boosts the bike backwards off

the Plate. Power is again cut when the bike is clear and again, it will not yet have sufficient momentum to go over the top so and will swing downwards and forwards. As it hits the Plate another burst of forward power is applied and so on, backwards and forwards until the bike does go right over the top in a complete forward circle. From then on, short bursts of power as the bike crosses Plate 6 will keep it spinning indefinitely.

To stop the model, it is sufficient simply to keep power off, as the “dead” motor will act as a brake, but increased braking can be achieved by reversing drive at the appropriate moments. Starting or stopping, however, this model stands out as something really different and I, for one, can recommend it as a thoroughly enjoyable “fun-piece”. Meccano Clubs, particularly, may like to study it, as it strikes me as being especially suitable for exhibitions, where members of the public are invited to “have a go”. Purely an idea, of course . . .!

### PARTS REQUIRED

4-1	1-17	12-70	1-133
2-1b	1-18a	2-80c	2-142a
6-5	2-20a	5-81	1-186a
4-6	1-22a	1-90a	1-197
8-7a	1-23a	4-99	2-199
13-8	190-37a	8-103a	2-222
4-9e	134-37b	2-111	8-235
4-10	50-38	2-111a	4-235a
5-11	2-48c	9-111c	2-235d
3-12	8-52a	4-111d	2-502
1-12b	3-53a	1-123	1-533
1-12c	8-59	1-126a	1-551
1-13	2-62b		
1-3-12 volt Motor with Gearbox.			

### AMONG THE MODEL BUILDERS (continued from page 227)

news to pass on to readers in the Chatham area. In January, Mr. Potter wrote to tell me that he and fellow enthusiasts in the area are forming a Meccano Club for adult enthusiasts over 15 years of age. Unfortunately, as I write this, I do not yet have any specific details as to Club title, officers, or venue, but Mr. Potter did tell me that, in the two months before he wrote to me, they were proving successful. Anyone interested in the Club should contact Mr. Potter at 8 Batchelor Street, Chatham, Kent.

### Stevenage Club

Still on the subject of Clubs, I have received some further news of the Stevenage Meccano Club from Secretary, Mr. Dennis Higginson, 7 Buckthorn Avenue, Stevenage, Herts., who writes to tell me that 10-year-old member Geoff Long has

developed an interesting way of meshing Part No. 25 with Part No. 31; Part No. 26 with Part No. 27 and Part No. 26c with Part No. 31. (Needless to say, these are parts which do not mesh together when standard Meccano spacing is used.)

I include an illustration of the demonstration mounting suggested to me and you will see from this that the secret of Geoff’s success lies in the use of Wheel Discs—both 6-hole and 8-hole—for the Rod journals. By journaling the Rods carrying the gears in the Wheel Disc holes shown, the non-standard engagement can be achieved.

The demonstration mounting is simply produced from a 5½ × 2½ in. Flanged Plate, to which three pairs of 1½ × ½ in. Double Angle Strips are bolted to provide support for the Wheel Discs. Working from left to right, two 6-hole Discs 1 are

bolted to the first pair of Double Angle Strips, two 8-hole Discs 2 to the centre pair and two more 8-hole Discs 3 to the right-hand pair. The left hand arrangement supports gears 25 and 31, the centre supports gears 26 and 27 and the right-hand supports gears 26c and 31, the particular holes used being clear from the illustration. Having myself built the unit illustrated from details supplied by Mr. Higginson, I can confirm that everything works as claimed and should consequently like to offer my hearty congratulations to young Geoff for his ingenuity. Well done!

Remaining with the Stevenage Meccano Club, I should like to close this month with an apology to Club member Peter Phillipson. Peter was mentioned in the January issue—only I referred to him as Phillip! My apologies, Peter.





## NATIONAL PARKS ON STAMPS

IN September 1870 a group of explorers gathered round a camp fire in the Yellowstone district of Wyoming and out of their casual conversations arose a plan for the preservation of parts of America from commercial exploitation. In this modest way the national parks movement began, culminating two years later in the establishment of the Yellowstone area as the world's first national park. The centenary of this event is being marked by the release of eight stamps featuring some of the varied scenery in America's national parks.

The first of these stamps, released on March 1st, featured the famous geyser 'Old Faithful' in the Yellowstone park. Yellowstone, which sprawls over 2,213,207 acres in northwestern Wyoming, eastern Idaho and southwestern Montana, contains more geysers than the rest of the world combined. This is Old Faithful's second appearance on a stamp. In 1934 the United States released a series of ten stamps in honour of National Parks Year and featured the geyser on the 5c value. It is interesting to contrast the treatment of the two stamps. The 1934 issue was printed in blue, whereas the latest version is multi-coloured and produced in the combined processes of intaglio and offset-lithography.

Other stamps in the 1934 series featured the stupendous El Capitan cliff in Yosemite (756,294 acres of California set aside in 1890), the temples of Deva, Brahma and Zoroaster in the Grand Canyon (645,084 acres of Arizona established in 1919), the forests and glacial peaks of Mount Rainier and Mirror Lake (241,219 acres of Washington, 1899), the cliff palace and prehistoric dwellings of Mesa Verde (51,017 acres of Colorado, 1906), Wizard Island and Crater Lake (160,290 acres of Oregon, 1902), Great Head promontory, Acadia (28,291 acres in Maine, 1919), the Great White Throne rock at Zion (94,241 acres in Utah, 1919), Mount Rockwell and Two Medicine Lake in the Glacier National Park (997,486 acres of Montana, 1910) and Mount Le Conte in the Great Smoky Mountains (460,882 acres of North Carolina and Tennessee, 1930).

Subsequently stamps have honoured other national parks. The dedication of the Everglades national park in 1947 was marked by a stamp depicting a Great White Heron. The Everglades, a large swamp in Florida, has an area of 5,000 square miles. The 25th anniversary of the Mount Rushmore National Park (1,686 acres in South Dakota) was celebrated by a stamp in 1952 featuring the colossal portraits of Washington, Jefferson, Theodore Roosevelt and Lincoln carved out of the cliff face between 1927 and 1941. John Muir, the Scottish-born pioneer of conservation in America, was portrayed on a stamp, against a background of giant redwood trees in California, released in 1964.

The second instalment in the current national parks series is a block of four 2 cent stamps which appeared on



April 5th. This block introduces a new feature to American stamp design, in that the stamps combine to form a single picture, yet each is a separate stamp in its own right. The upper left stamp shows a ship's hulk, pounded by the Atlantic Ocean. Upper right is the Cape Hatteras lighthouse, surf fishermen and surf-bathers. Lower left and right feature Laughing Gulls perched on driftwood. The Cape Hatteras National Seashore, consisting of 45 square miles of beach, was established in 1937. Nearby is Roanoke Island, where the first English settlers lived in 1585 and a few miles distant is Kitty Hawk, scene of the first powered flight by the Wright Brothers in 1903.

Later in the year there will be further stamps in the series, depicting Wolf Trap Farm, Virginia (6c), the City of Refuge, Hawaii (11c airmail) and Mount McKinley, Alaska (15c). This will also be the second appearance of this mountain on a stamp. It appeared on a 3c stamp of 1937 in honour of the Territory of Alaska.

Many other countries have followed America's example and established national parks for the preservation of plants, wildlife and scenery. Relatively few of them, however, have featured these parks on stamps. Notable examples include Czechoslovakia, which has issued numerous stamps depicting scenery and wildlife in the Tatra National Park, and Poland, which has produced several stamps since 1953 featuring the Tatras and forest reserves. New Zealand has ten national parks and one maritime park and most of these, at some time or another, have been featured on stamps, ranging from the 1898 pictorials showing Mount Cook, Milford Sound, Lake Wakitipu, Mount Ruapehu and the Otira Gorge, to the current definitive series, released last year, which shows four national parks—Mount Egmont (23c), Hauraki Gulf Maritime Park (25c), Mount Cook (30c) and Abel Tasman National Park (50c). Previous issues have included the Tasman, Franz Josef and Gox Flaciers, the Southern Alps, Fiordland and Mount Aspiring National Parks.

The record for the most national parks, and the greatest number of stamps to publicise them, must go to Japan. Mount Fuji, on whose slopes are several national parks, first appeared on stamps in 1922, but fourteen years later a set of four stamps was devoted to the Fuji-Hakone National Park. In 1938 seven sets of four stamps were released and showed scenery from ten different parks. The issue of National Parks stamps was resumed in 1949 and since then more than 150 stamps have publicised the national parks—not to mention those stamps in which a view of a national park landmark has been incorporated though not specifically commemorating that park. With the present emphasis on conservation and the protection of the environment from pollution, national parks will become more important, and no doubt many more stamps will be issued with this theme.

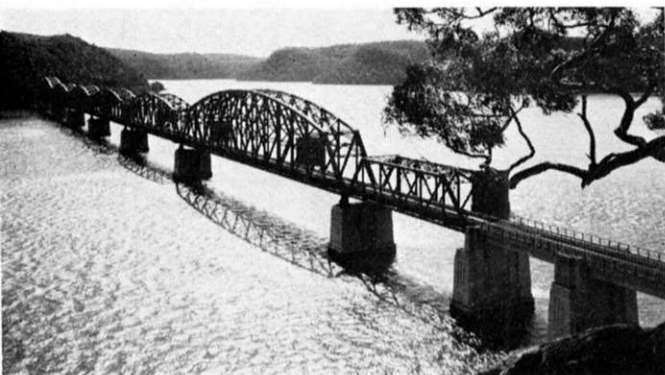

# THE DESIGN AND CONSTRUCTION OF BRIDGES

PART FOUR

BY TERENCE WISE

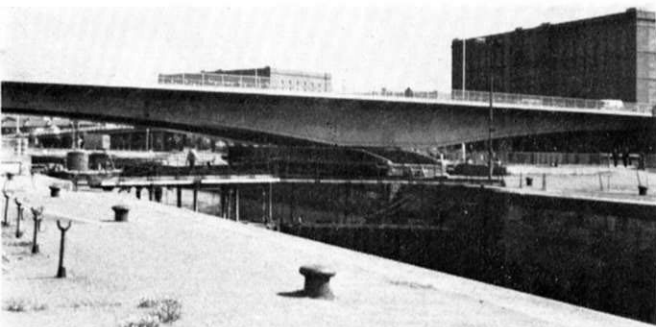

A NATURAL development from the cast iron ribs used for arch bridges was the girder and the girder bridge, which in its simplest form consists of several beams laid horizontally across an opening between abutments, with some kind of deck laid on top. In larger bridges there are main girders to carry the weight of the superstructure and its loads, cross girders to connect them transversely and support the deck, while in many railway bridges a third series of small longitudinal girders runs under the rails of each track. In the last century the basic principles of girder construction were used to build such famous bridges as the Tay, Britannia tubular, Newcastle high level and London's Tower bridge, and also gave rise to the more sophisticated cantilever girder bridge. You are most likely to see an example of the girder bridge in its ugliest form, for it is more commonly used these days to carry railways over roads, usually with spans not exceeding 120 feet.

The girder bridge differs from the arch and suspension bridges in the way that the stresses are exerted on its supports. The thrust of the arch ring and the pull of the suspension chains are restricted by strongly built abutments, but the main beams of a girder bridge exert only *vertical* stress on their supports. The stresses within the bridge itself are also different. When a beam which is supported at each end carries a load it undergoes three different types of stress: the compressive and tensile stresses on the upper and lower surfaces of the beam respectively, and a shearing stress through the solid section of the beam. The modern girder is designed to resist these stresses and is built up in three parts: an upper flange, a lower flange, and between them the vertical web.

The earliest girders were made of cast iron. Because this material is stronger in compression than in tension the girders were made with a wider lower flange to increase the resistance to tension (Fig. 1A). Cast iron girders continued to be used for spans of up to about fifty feet, especially for railways, when the ends of the girders were embedded in brickwork to add to their load bearing capacity. Many of these bridges are still in service today. Figs 2 and 3 are examples of such iron bridges, built for the railways in Berlin during the last century.

With wrought iron and mild steel no such inequality of stresses exists and the ordinary girders are made up as shown in Fig. 1B. This type of girder is used for the subsidiary parts of a bridge. Main girders are made up from angle bars and plates as illustrated in Fig. 1C and these are called plate girders. Sometimes the girders are made with a double web, forming a hollow rectangle, and these are known as box girders (Fig. 1D). The massive tubular girders of the Britannia bridge are in fact box girders, carrying the railway inside the box. In this case the roof and floor of the tubes are the upper and lower flanges and the plate side walls are the double web, but in violent side-winds the plate walls perform the function of the flanges and vice versa. The depth of the girder is normally between 1/8th and 1/12th of the span, on the principle that the greater the depth of the girder the stiffer it will be.

For spans of over a hundred feet the web is built up considerably in height, but in order to save weight the girder becomes a lattice girder—Fig. 4. In this case the plate is replaced by criss crossing bars and the stresses of

Top to bottom, the Hawkesbury River Bridge, 35 miles north of Sydney, was designed and built by the N.S.W. Department of Railways. The Ashton Swing Bridge, Bristol, one of the many box girder bridges at present under restricted use. The Hungerford Railway Bridge over the Thames between Charing Cross and Waterloo Stations, seen from under Waterloo Bridge. Barnes Railway and footbridge, built about 1860.

the web are resolved into pulls and thrusts, some of the bars acting as struts and others as ties. An even more effective method for the larger constructions is to leave out some of the crossing bars and concentrate the stresses on a smaller number of members. This gives a braced girder of inclined struts and ties, Fig. 5A, or of vertical struts and inclined ties, Fig. 5B. Another variation is the bowstring girder, Fig. 6, in which the upper flange is reinforced in the centre by an extra horizontal member with bracing between them.

Girder bridges may be divided into deck and through deck bridges, according to the position of the deck in the superstructure, and single or continuous span bridges. Fig. 7A is a cross section of a deck bridge with the deck carried on top of four main girders, while in Fig. 7B the deck goes through the bridge, as for example in the Britannia tubes already mentioned. This method is mainly employed in larger bridges and consists basically of two main girders with braced web systems A-C and B-D forming the two sides of the bridge, the floor C-D on cross girders braced together diagonally like a horizontal web, and the overhead system filled in a similar manner by an arrangement of girders between A and B to provide wind bracing.

A single span girder bridge is one which reaches from support to support without projecting beyond those supports. Fig. 8 shows the make-up of one of the seven 416ft. spans of the Hawkesbury River single span girder bridge in New South Wales. Each span is fixed to a pedestal bolted on to the pier or abutment on which it rests, and the other end rests on rollers to allow for expansion. The total length of this bridge, which was built in sections and transported to the site by road in sections weighing up to 24 tons, is 2,900 ft. 3 in. Finding solid foundations on the thick silt bed of the river presented a problem for the builders, and some of the piers go down 183 ft. before touching a solid base.

A continuous girder bridge is one which crosses two or more spans, usually three, in one continuous length, the girder being laid upon three or more supports. In this type of bridge the stresses are rather hard to determine. The method employed to allow for expansion is to fix each span to one support and allow it to expand in both directions. However, this makes it difficult to estimate the total expansion, owing to variations at several such openings, and this type of bridge is not found much in Europe, although it is popular in America. Examples of continuous girder bridge are of course the Britannia and Conway tubular bridges built by Robert Stephenson. In the former, which has two spans of 460 ft. and two of 230 ft., the expansion and contraction variations amount to four inches at each end. The Britannia, built in 1850 over the Menai Straits, was the pioneer of the continuous girder bridge. In more recent times the Cologne-Deutz bridge, a continuous plate girder bridge with a 605 ft. span, was completed in 1948 over the Rhine at Cologne, using the piers of the 1915 suspension bridge of the same span which was destroyed in World War II. The Dusseldorf-Neuss bridge, with a span of 676 ft, was completed in 1951.

In recent years many box girder bridges have been built in different parts of the world, the design originating in West Germany. These are designed in sections, rather like the outer casing of a matchbox, which are then joined together to form the bridge deck. This method is fifty per cent cheaper than conventional designs but unfortunately several of the bridges have collapsed with great loss of life and last year restrictions were imposed on the use of 51 box girder bridges in Britain. Work on another 39 was suspended and the design subjected to investigation and rigid rulings on the standard of construction. However, the issue is still in the air and much

has still to be explained, particularly in the difficult field of stress.

FIG 1

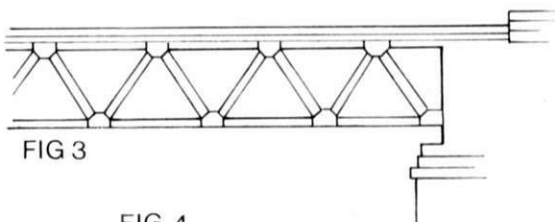
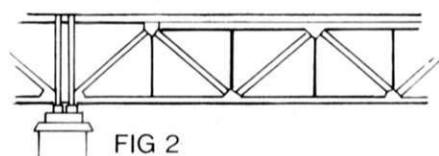
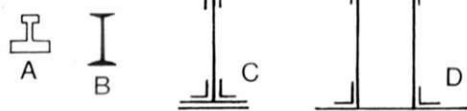

FIG 3

FIG 4

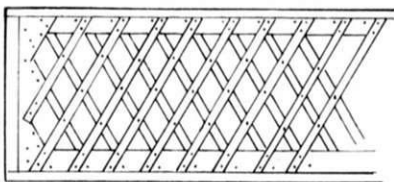

FIG 5

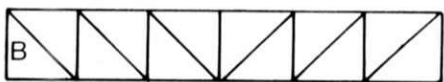

FIG 6



FIG 7



FIG 8

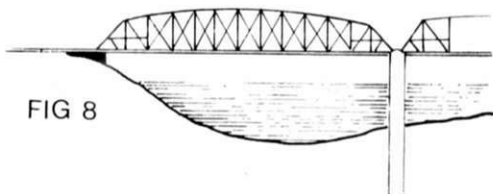



Left, the large number of vehicles converging on Smithfield calls for careful parking and traffic control.

Below left, bummarees seem to be happy in their work and find time for a joke as they move the meat.

Farringdon Without, it is owned by the Corporation of London, who set up a cattle market in 1628 by Royal Charter.

London Central Markets, to give the official title, pay rentals and tolls. Rentals are charged according to the shop site leased but tolls are fixed at 11p per ton (or 4d for every 21 pounds, before farthings went out of circulation).

Over 200,000 tons of meat and poultry from Britain join Commonwealth and foreign imports to bring in a total revenue from tolls of £42,000 a year.

If all the produce sold walked through the market, the procession would amount to one million cattle, 4 million lambs, 19 million poultry and 1,200,000 pigs, while, if the meat hooks were stretched end to end, they would cover a distance of about 45 miles.

Today, from Monday to Friday between the hours of 5 a.m. and 1 p.m., buyers and sellers are busy in three sections—Meat, Poultry, and General.

The unloading, or pitching, as it is called, is usually finished by 5 o'clock in the morning. About 80 wholesalers control the home-killed produce and imported carcasses. Since buyers and sellers are both out to obtain the best possible sale, some keen bargaining occurs.

Naturally, weather affects the supply and the demand and also affects prices which change so rapidly that the market publishes a Daily Report to help traders. This tells the prices and also the quantity of goods flowing through the Market.

## “To Market, to Market, to buy a Fat Pig”

— or a side of beef, or lamb, or  
poultry—Smithfield has them all  
by E. Harper

NEARLY 900 years ago a man called Fitzstephen, clerk to Thomas à Becket, described a “plain grassy space just outside the City Walls”. Known to Londoners as the Smooth Fields, he told how “every Friday there is a celebrated rendezvous of fine horses to be sold and in another quarter are placed vendibles of the peasant, swine with their deep flanks and cows and oxen of immense bulk”.

Today Smithfield, as that market place is now called, offers the best range of meat and poultry to be bought in the world. Covering 10 acres in the ancient ward of

Outside, the imposing domed tower rises high above the market place.



Right, small man—big load. Smithfield porters can move heavy barrow loads in their daily work.

Below right, every type of carcase hangs from the hooks in Smithfields' alley ways.

How amazed Fitzstephen would be if he could see his 'grassy space' today! Over £4,000,000 has been spent in building the modern market. In 1886 two sections were built and more were steadily added until 1899. Then fire destroyed the major part of these, but another £2,000,000 was spent to put up the present Poultry Market in 1963.

Smithfield has every amenity for its workers. Automatically controlled ventilation, vast areas of cold storage, offices, changing rooms and good lighting all help the smooth flow of trade.

1965 saw another improvement when the Fish, Fruit, Vegetable and Flower section opened. Here about 1,000 workers have separate lockers, parking space, showers with shops and an automatic machine for washing trucks.

A branch line from the Metropolitan Railway conveys meat to the crypt. The buildings are mainly of red brick, Portland stone and cast iron for gates, lamps and ornamental work with more modern cement blending into the whole architectural design.

Smithfield is unique in many ways. Its inn, 'The Cock Tavern', is open from 6.30 to 9.30 a.m. and 11.30 a.m. to 3 p.m. Here snacks are available at all hours of the day. Formerly customers could buy 'wizzer' (tea and whisky) from 4 a.m. There is a special police force, and a cleaning force, for refuse has to be collected and the area kept hygienic. 7,000,000 units of electricity used annually means a staff of electricians on the spot. Porters number 600, while self-employed porters,



called 'bummarees', also work in the market. Their white coats and strange half-trotting gait with carcasses on their heads is also unique to the market.

Naturally, with such a long history of selling, prices have altered dramatically. 14th century butchers paid 5/6 for oxen, 16/- for a bullock and 12/- for a cow or pig. Henry VIII's butchers suffered controlled prices with 1/4d lb. as the maximum beef price; mutton went for three farthings a pound.

Close by the market, in mediaeval times, archers, entertainers and fair men held revelry. On the other side, public executions took place. Here Rahere, the Jester, founded his hospice of St. Bartholomew nearby. From 1100-1855 St. Bartholomew Fair was held by the market on August 4th. There was a tragic side to the area as well, for public executions formed a gruesome entertainment and hundreds of people were burned at the stake for their religious beliefs. From 1554-58 200 martyrs died at Smithfield.

The market has seen Britain in the making and supplied the roast beef of old England to centuries of citizens. Its service and standard is unrivalled by any market in the world. Without such service, butchers throughout Britain would find providing our meat difficult and costly, with resultant higher prices in our shops.

There is no pause in the stream of meat-laden barrows as our meat supply flows in and out of the market.



# BIG BEN

## BRITAIN'S BEST LOVED CLOCK

by E. V. Malone



ALTHOUGH Britain's best-loved clock is known affectionately as "Big Ben", this name was actually given to the bell cast for the clock of the Houses of Parliament which was being built to replace that destroyed by fire in 1834. Whilst the design of the complete structure of the new House was entrusted to Sir Charles Barry, the clock itself was decided by public competition, one condition of all entries being that they would not gain or lose more than one second daily. Whichever proved to be successful, Sir Benjamin Hall, the *Chief Lord of the Woods and Forests* (the Minister of Works in modern parlance) assured M.P.'s that it would be "a Noble Clock, the biggest and best in the world, within sight and sound of the heart of London".

Duly made in a foundry at Stockton-on-Tees, the aforementioned bell, weighing 16 tons, was conveyed by boat to London. Thence a team of sixteen pure white stallions decked with ribbons drew it in a wagon to Westminster where, unfortunately, it was found to be defective. Meanwhile, however, Parliament was debating at length the question of a suitable name for it but were unable to reach agreement on any particular designation. Even Sir Benjamin, in winding up the discussion, had no more originality than to suggest "St. Stephen", after the tower in which it was to be installed. Strange as it may seem, the image of this stately and portly figure was enough to set alight a spark, for as soon as he reclined in his seat and mopped the perspiration off his brow, a wit thoroughly bored with the whole proceedings, without waiting to catch the Speaker's eye, shouted from the back benches, "Why not call it 'Big Ben' and have done with it?" As this was none other than the sobriquet of the Honourable Gentleman, the proposal was at first greeted with loud laughter but on second thoughts was adopted.

Be that as it may, it was necessary to recast the cracked bell, which work was carried out by the Whitechapel firm of Messrs. Mears and Stainbank (the oldest foundry in Britain) to a specification of Lord Grimthorpe, losing as it did over two tons in the process. As luck would have it, the product once again did not attain the standard aimed at, this time on account of a moulding error. Nevertheless, this was rectified by reducing the weight of the hammer and adjusting it to strike a different spot on the bell, producing the unique and distinctive tone we know.

Finally "St. Stephen", as it was christened, was hauled into position and everything seemed in order. A large crowd waited expectantly for the clock to tick into action but their disappointment is readily imagined when the timekeeper refused to budge due, it was discovered, to the extra-heavy hands. Presently lighter ones were substituted and on May 31, 1859, it began its triumphant march into history.

As expected, all the features of the clock which looks out over London's streets at a height of 184 feet up the 316-foot tower are of a gigantic size. On each of the four dials no less than 25 feet in diameter are the numerals two feet in height and six feet apart and minute divisions measuring a foot square. The minute and hour hands circumscribing them are 14 and 9 feet long respectively, the former consisting of copper weighing 2 cwt. and the latter of 6 cwt. of gun-metal. The distance travelled by the tip of the minute-hand works out in the region of 100 miles yearly. Do you know that when Parliament is sitting, the tower and clock-faces are illuminated?

To reach the mechanism, one ascends a staircase of

(Continued on page 249).

Heading photo, Big Ben rises high above the trees in Parliament Square. Left, Big Ben and Queen Boadicea as seen from the steps beside Westminster Bridge.



# AIR NEWS

By

**JOHN W. R. TAYLOR**

## Breguet Goes Mountaineering

It is no longer news when a small helicopter touches down on a ledge high in the mountains to rescue an injured climber. Such incidents are routine, as are the operations by ski-equipped light transports of Air Alpes into short, sloping altiports many thousands of feet up among the high peaks of the French Alps. It is, however, a different matter when somebody tries to fly a 25-ton four-turboprop transport from the same strips!

The Breguet company, now part of the powerful Avions Marcel Dassault-Breguet Aviation group, has spent the last ten years persuading the French Air Force and world airlines of the capabilities of its Br 941S STOL (short take-off and landing) aircraft. The original prototype flew for the first time on June 1, 1961, and soon began to prove that it could fly into and out of places that were far too restricted for other large transports.

Key to its remarkable performance was its wing. Although comparatively short, this was fitted with full-span double slotted flaps, and the four propellers were so big that their slipstream "blanketed" the entire wing when the turboprops were running. This combination of slipstream over the wing and high-lift flaps enabled the Br 941 to leap safely into the air after an incredibly short run and to land in an even shorter distance. To prove this, Breguet flew it into the city-centre heliport in Paris, not far from the Eiffel Tower.

Over in America, McDonnell Douglas Corporation was sufficiently impressed to borrow the prototype for demonstration to US airlines, and to start designing a version to be known as the McDonnell Douglas 188 specially tailored to meet American military and commercial requirements. The French Air Force, too, decided that the idea was worth investigating further and ordered a pre-production batch of four Br 941S transports.

The 941S has a longer nose than the prototype, housing a weather avoidance and navigation radar scanner. The cockpit is enlarged, the windows improved to give the crew better visibility, the cargo hold widened, and the doors under the rear fuselage redesigned to permit the air-dropping of heavy loads. Powered by four 1,500 h.p. Turboméca Turmo IID6 turboprops, the 941S can carry a full load of 57 commercial passengers or 40 fully-equipped troops 620

miles at 248 m.p.h. Top speed is 280 m.p.h., maximum range 1,925 miles, take-off run 655 ft. at reduced all-up weight for assault missions, and landing run a mere 345 ft. in the same role.

First flight of the 941S was made on April 19, 1967, and all four aircraft were soon ready for evaluation by the French Air Force. One emigrated to America for a time, in 1968-69, and was operated experimentally in the full livery of Eastern Air Lines and American Airlines. But still nobody has ordered any more 941s.

The fact that this aircraft looks so conventional may have caused air forces and airlines to overlook it in favour of more glamorous and "different" projects with tilt-wings, rotating wings, jet-lift engines and other new techniques. The fact remains that few of these other ideas have yet proved viable for operational transport aircraft, whereas the Breguet 941S has shown itself to be an entirely practical transport, able to do precisely what it was designed to do.

For that reason, the pilot who flew a French Air Force 941S into the altiports of Meribel, Megeve and Alpe d'Huez last October knew that he had little to fear from the forbidding mountains on all sides, or the drop of hundreds of feet not far from the end of some of the strips. The big transport touched down and took off with no more difficulty than Breguet had expected, blazing a trail that must be followed one day by other airliners, carrying people in comfort to sunlit winter resorts high in Europe's greatest mountain range.

## Naval Stol

Another European STOL transport that can be seen in military insignia is the Dornier Do 28 D-1 Sky-servant. Much smaller than the Breguet 941S, it carries up to 13 passengers at 143-178 m.p.h., on the power of two 380 h.p. Lycoming IGSO-540 piston-

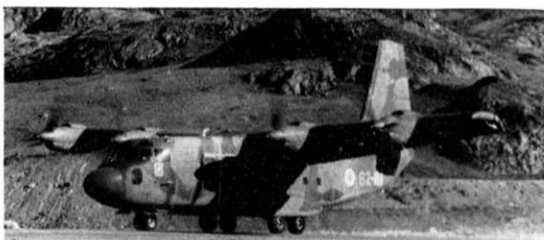

The photos on the right and above show the Breguet 941S STOL on an altiport in the French Alps.

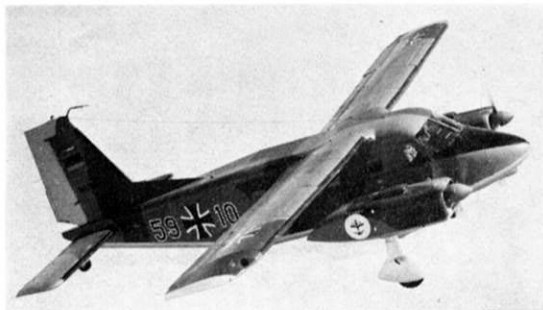

The Dornier Skyservant, this one belonging to the West German Navy.

German Government ordered 125 for its armed forces and deliveries to the Luftwaffe started some time ago, for VIP transport, ambulance and other duties. Now the German Navy is also putting Skyservants into service. These aircraft are camouflaged in the same way as their Luftwaffe counterparts, but carry the word MARINE on their tail-fin and have a winged anchor painted on each engine nacelle, as shown in the photograph on this page.

engines. Nor does it use the deflected-slipstream technique of the French aircraft. Instead it relies entirely on its high-lift wings, which are fitted with double-slotted flaps and a full-span leading-edge fixed slot. They enable it to take off and climb to a height of 50 ft. with a full load in a distance of only 380 yards.

Although sturdy and uncomplicated, with a fixed undercarriage, the Skyservant is a very "clean" design. The wings are cantilever, which means that they need no bracing struts to support them, and the neatly cowled engines are mounted at the ends of short stub-wings which also carry the main wheels.

The prototype first flew on February 23, 1966, and the Skyservant eventually replaced in production the Do 28 B-1 which, despite the similar designation, was a smaller and less powerful six/eight-seater. The West



Above and below is the Plane-Mate joined to a McDonnell Douglas DC-10 of the American Airlines. Below right, a view inside a Plane-Mate.

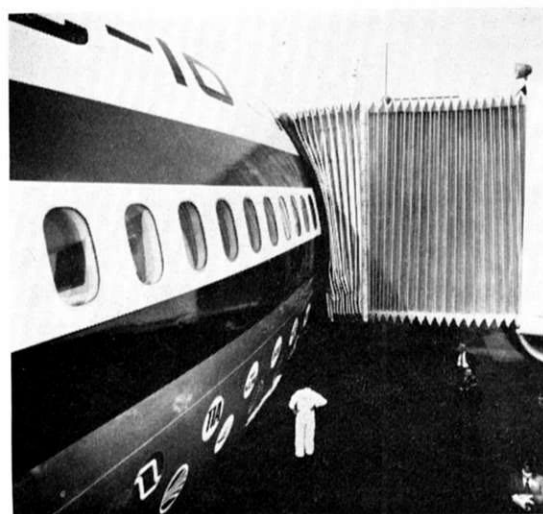

### Plane-Mates Speed Jumbo Loading

One of the unique features of Dulles International Airport at Washington, when it first opened, was the use of mobile lounges. Passengers waiting to board their aircraft simply entered a comfortable lounge which, in due course, propelled itself to the airliner, so avoiding the need for separate coaches.

Eastern Air Lines knew all about the attractions of the mobile lounge when they had to find a more efficient way of getting passengers from terminal to aircraft and vice versa, at Atlanta Airport, Georgia. Winter brings cold rains in that area, so there was little enthusiasm for any scheme that involved walking through the weather between bus and aircraft. "Finger" buildings leading from existing concourses were equally unpopular. Their cost is high and they take up valuable space on the parking apron. Nor were pivoting overhead enclosed gangways any better, as they work best where aircraft are towed into position to mate up with them, and tugs have never been used at Atlanta.

The answer came from a company named Boothe Airside Systems, whose engineers had spent years trying to solve such problems. The end product of their studies is the Plane-Mate, which offers all the advantages of the original mobile lounge, plus the important fact that it can be raised as much as 18 ft. 8 in. above the ground to mate with the cabin doors of any large modern aircraft in service or under development.

Up to 150 passengers can travel in each Plane-Mate, 94 of them on wide seats with space for carry-on baggage underneath. The interior of the "pod" is well-lighted, carpeted, cooled in summer by 10-ton air conditioners and warmed in winter by electric heaters. When it reaches the aircraft, the pod can be elevated to its full height in just over one minute, eliminating all necessity for passengers to climb steps. There is not even any need for the Plane-Mate to drive up "square" to the cabin, because it is linked to the aircraft by a flexible, rotatable gangway that can extend up to 10 ft. 4 in. from the lounge. Once in position, this gangway





**The RotorWay Scorpion two-seater comes very close to the conception of an aerial motor-bike. Looks fun.**

forms a weather-tight vestibule between the Plane-Mate and aircraft, level with the latter's cabin floor.

The pod is 40 ft. long by 15 ft. 6 in. wide and is mounted on a four-wheel chassis powered by a petrol or diesel engine with automatic transmission.

Since the first Plane-Mate came off the assembly line in December 1970, twenty have been delivered to customers in the USA. American Airlines has four, Pan American three, the Port of New York Authority eight, the Federal Aviation Agency two for use at Dulles (with ten more to follow), and Eastern Air Lines three. Eastern's Plane-Mates, at Atlanta, are already handling some 12,000 inbound and outbound flights each month, with an average of 300,000 passengers.

### Scorpion for Two

Back in the early 'sixties a young American engineer named B. J. Schramm set out to design and build a small single-seat helicopter on which he could teach himself to fly. It was an ambitious plan, as "choppers" are notoriously difficult to develop and few of those intended for amateur construction have been really practical.

Schramm's prototype, which he called the Javelin, flew for the first time in August 1965. It proved so successful that he formed a company named RotorWay, Inc., to market plans and kits of parts to enable other would-be pilots to construct an improved version of the Javelin, known as the Scorpion. If the customer is short of cash, he can buy a few parts at a time. Alter-



natively, if he is a skilled craftsman, he need buy only the plans and rotor blades from RotorWay, making the rest of the aircraft himself from raw materials.

The basic Scorpion has a two-blade main rotor, 19 ft. 6½ in. in diameter, and a two-blade tail rotor, driven by a 115 h.p. water-cooled Evinrude four-cylinder outboard engine. Its steel tube fuselage is 17 ft. 1¼ in. long when fitted with the standard removable glass-fibre body fairing. Maximum speed is 90 m.p.h. and cruising range 105 miles at 68 m.p.h.

Although such aircraft are fun, there comes a time when the pilot wants to take along his girl friend or wife. RotorWay have, therefore, produced the prototype of a side-by-side two-seat Scorpion with a bigger engine. As can be seen in the picture on this page, it looks a thoroughly professional and exciting aircraft in every way.

### BIG BEN (continued from page 246).

374 steps. Here are the pendulum which beats every two seconds with its 4-cwt. bob, and the indispensable weights weighing 2½ tons. The pendulum is so delicately balanced that its tendency to err by about one-tenth of a second in the course of a day is rectified merely by adding or subtracting a halfpenny coin to or from the tray holding several weights and attached halfway down the length of the shaft. For this purpose a check is kept on it by means of a cable linking it with Greenwich Observatory.

It is an indisputable fact that no other mechanically-operated public clock throughout the world is as efficient as this five-ton "giant". The longest deviation ever recorded by it was merely of four seconds' duration. Yet there have been some strange episodes in its life to date. For example, in 1861 when the Prince Consort lay on his deathbed the winding-apparatus inexplicably stuck, causing the bell to strike 100 times in succession, and five years later it came to a dead halt due to clogging of the lubricating-system.

External agents also have contributed their share towards stoppages, such as rats nesting in the works, starlings roosting on the hands, ladders, spanners, pots of paint and a flapping tarpaulin inadvertently left behind by workers cleaning or painting the dials, not forgetting frost and snow. According to an agreement made between the makers, Messrs Dent of Pall Mall and the Ministry of Works, the works of "Great Westminster Clock", to give its official title, have always been overhauled free of charge. The most recent full-scale renovation programme known to the writer was carried out in 1955-56 at a cost of £66,000 and involved repairs to the stonework and roof of the tower which were badly shaken when German bombs destroyed the main building in May, 1941. The opportunity was then

taken to redecorate the interior and reglaze three of the faces, each of which contains 312 panes.

Although the repairs took 18 months to complete, it was necessary to stop the clock for only two months. During this time, "Big Tom" of St. Paul's Cathedral deputised for the fraternal "voice" so familiar to millions of wireless listeners.

The chimes, indeed, made their radio debut on New Year's Eve, 1923. After initial experiments to capture them proved unsatisfactory, success was achieved by concealing a microphone in a football bladder on the side of the bell nearest to the river. This method was used for many years in spite of the unwelcome yet ineffective attacks of pigeons on the rubber. Nowadays, of course, a more efficient piece of equipment is employed there and by means of a switch in the Control Room of Broadcasting House the vibrant strokes can be sent booming through the ether to the far distant corners of the globe in a matter of seconds. During the war years especially, "The Signature Tune of the Commonwealth" was an effective link binding the Mother Country and its family closer than ever together.

No wonder that on her visit for the Coronation of Queen Elizabeth, Queen Salote of Tonga ordered a clock with the entrancing chimes from a Derby firm for her palace chapel in the Friendly Isles. Incidentally, they are sometimes erroneously spoken of as "Westminster" chimes but the correct name is "Cambridge" as they were originally rung in a Cambridge church. But how many know that the tune they play comes from the following verse in *Messiah*:

"All through this hour,  
Lord, be my guide,  
And by Thy power  
No foot shall slide."?

Long may this venerable timepiece continue to do so!



**M**ANY naturalists consider that out of the 8,600 (more or less) estimated species of birds throughout the world, the Black Swan of Australia is supreme in beauty amongst the water-loving types.

Throughout countless centuries the white swan of poetry, ballet and fairy stories was considered the finest example of grace and beauty. These days, however, to many the Black Swan, with its dusky-black plumage relieved by beautiful snow-white flight feathers and a crimson-banded beak, is superior.

Until the seventeenth century, it was axiomatic in Europe that "all swans are white". Then, near the end of the century, Willem de Vlamingh, the Dutch navigator and explorer, became the first European to sight a Black Swan.

Willem de Vlamingh sighted the birds while exploring a river in Western Australia. He named the river "Swaata Swaane Drift", which is now called the Swan River after the four birds he captured there.

With the birds aboard he sailed on to Batavia, and from Java one or two were shipped to Holland. These four black swans, therefore, were the first members of Australian wildlife ever to be exported.

In 1698 the first news of Black Swans was published in England in the "Philosophical Transactions of the Royal Society". The printed report came from a letter which Dr. Martin Lister had received from Holland describing their discovery.

The Black Swans are sociable birds, and are found in pairs and flocks. Large numbers have been known to congregate in safe, well-favoured localities. Their natural habitat is inland waters, as well as coastal swamps, lakes, lagoons and river estuaries; also harbours and bays. But they are not sea-going birds.

Swans feed by tipping up and reaching to the bottom of shallow water for the plants growing there. Their main diet consists of fish, water-plants, yabbies and other small water creatures. They choose to feed in deeper water than geese and ducks, probably because they have longer necks.

The Black Swans rarely call during the daytime, yet

## AUSTRALIA'S BLACK SWAN

By Frank Madigan

they trumpet loudly in the early evening or on bright moonlight nights, as they fly from one feeding ground to another. As Charles Barrett, F.R.Z.S. put it, "the Black Swans' fluting calls are wild Austral music, haunting and toned with music".

Their breeding season begins early; in fact, cygnets have been seen even as early as June, cruising around with their proud and watchful parents.

The nests, bulky structures of sticks and twigs and aquatic plants, sometimes mingled with gum leaves, are found in solitary or scattered groups. In these nests the mother swan lays from five to seven pale green eggs.

Both birds are very attentive to their eggs, and also to the young, and will attack intruders who approach their nest. Once the cygnets are hatched, they stay close to their mother, who often hides them from harm among the reeds and rushes.

In the early days of settlement, the aborigines and settlers used many swans and their eggs as food. Experts say the old swans make tough meat, but that the young are tender and sweet.

These days 'koonwarra', the aborigines' musical name for the Black Swan, is fully protected.

Black Swans were very plentiful along the Murray River last century, and Major Mitchell, when he camped on the hill at the junction of the Murray and Little Murray Rivers in 1836, decided to name the place "Swan Hill".

The Black Swans, '*Chenopsis atrata*', are confined to Australia, though they have since been introduced into New Zealand.

Many Black Swans have also become acclimatised in England, Europe and North America.

The wild Black Swans of Australia, however, are a national heritage, and arouse in most Australians the sentiments so aptly described by Archer Russell: "There is something fascinating, almost rapturous, about a great black wedge of flying swans. As for that far, clear call that comes spilling from the skies, it is like the trumpet-call to some wild emprise, an evocation to the fulfilment of desire".

### POTATOES (continued from page 229)

are termed 'chat' potatoes and are used for livestock feeding. Cattle, pigs, sheep and poultry can all make use of, and enjoy, potatoes just as well as we can!

So a potato grower always has a large barn where the potatoes can be stored against frost, and where they can be sorted and graded for the market. This requires sorting machinery with conveyor belts and bagging off points and provides the farm labour force with a useful job to do 'indoors' when it is impossible to work outside due to really bad weather. For all the headaches that potatoes might cause a farmer, they are now a universal blessing of mankind. They have always been a versatile

food, and nowadays they are also manufactured into dehydrated powders which one can prepare to a cooked and mashed state by simply adding hot water.

Potatoes have come a long way since the first record that I have which mentions them in the household accounts of Queen Anne in 1613. They are described as a great and a rare delicacy costing about two shillings a pound. Today they equal rice and wheat and soya in nourishing the human populations of the world. Taking back-ache and expensive hand labour out of potato growing means that they will always be a low-price first-class food. And that is good news for everybody—thanks to the robot diggers of the countryside!

**MECCANO PARTS  
AND HOW TO USE  
THEM: No. 5**

## **WHEELS and AXLES**

**BY B. N. LOVE**

**P**ROBABLY the greatest appeal of Meccano models lies in the manner in which they may be animated by mechanical movement. Having dealt with the basic components for frameworks, we may now turn to those parts which give us motion in our models, namely, wheels and axles. With more than a dozen lengths of Axle Rods in the system (apart from the special Pivot Rods among the Electrical Parts), the Meccano constructor has a wide range of spindles to choose from and an even greater variety of wheels. These latter include Pulleys, Bush Wheels, Road Wheels, Spoked Wheels, Flanged Wheels and, of course, the entire range of Gear Wheels, although these will be dealt with as a separate class.

Once again, in using wheels and axles, the emphasis is on not taking things for granted. Both groups need looking after, as too many models are spoiled by bent shafts and distorted wheels, usually caused through rough handling or carelessness. Neither shafts nor wheels will stand up to excessive loads or abuse, but, properly used, they can carry substantial drives and surprising weights. Axle Rods should be carefully chosen whenever accuracy of running is required, especially in belt-driven or gear-driven mechanisms. Give these running parts a fair chance by lining up bearings with care and by seeing that the shafts turn without binding, or undue side play. Part of a simple four-wheeled truck shown in Fig. 1 demonstrates this principle. 1 in. Pulleys, mounted on 3 in. Axle Rods, are journalled in a pair of Flat Trunnions attached to the side of the standard Flanged Plate, but Washers are used under the Bolt heads for firm grip and the careful alignment of front and rear Axle Rods permitted this model to run on Girder rails.

Although not apparent from the illustration, each of the Axle Rods on

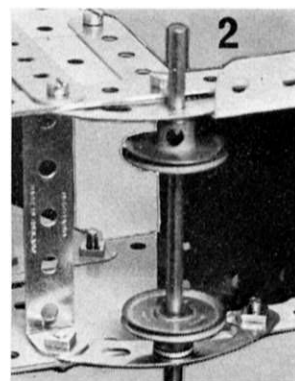
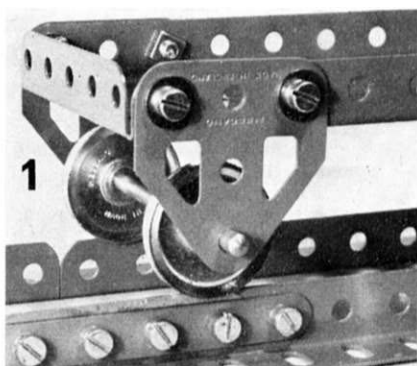

the simple truck carry Washers between the Pulley Wheel bosses and the inside of the Trunnions. The principle is illustrated in Fig. 2 where a similar construction is used for a model tram. By inserting the Washers shown, the 'scrubbing' action of the Pulley Wheel boss against the Trunnion is very much reduced and, if a small drop of sewing machine oil is applied to the bearing, scrubbing, and subsequent scoring of enamelled surfaces, is almost eliminated. Both the Trunnion and the 2½ in. Stepped Curved Strip appear in the majority of Meccano Outfits, so are readily available for the journals shown in Figs 1 and 2.

The Pulley Wheel comes into its own when used for a belt drive, an outstanding example of which is illustrated in Fig. 3. In this instance two 2 in. Pulleys, Part No. 20a, are used to receive a belt drive in a fairground model, the doubling-up of the belts providing a very powerful drive. A full range of Rubber Driving Bands are provided in the Meccano system, ranging from 2½ in. to 20 in. in light and heavy gauge to suit a wide range of models and power requirements. The smaller and lighter bands, Part

Nos. 186, 186a and 186b, are used in junior models with hand or clock-work drive, while the longer and heavy-gauge Bands, Part Nos. 186c, 186d and 186e may be used with electric motor drive in the heavier models.

Several advantages arise in using the Driving Bands. They enable moving parts located at a distance across the model to be coupled by Pulleys. They are silent in operation, have sufficient stretch to accommodate awkward shaft spacing, and a single twist in the loop of the Driving Band gives a reversal of drive.

When running models on rails, the Meccano Flanged Wheels, Part Nos. 20 or 20B, should be employed. These are wheels which can be easily put out of shape by carelessness or overloading, but it is a fairly simple matter to straighten them to run without wobbling. They should always be spun on an Axle Rod before use to ensure that they are running true or they will not give a level performance on rail-mounted models. Fig. 6 shows the larger Flanged Wheels as a pair, sandwiching a Wheel Disc to form a centre flanged wheel. This provides a very strong component for heavy

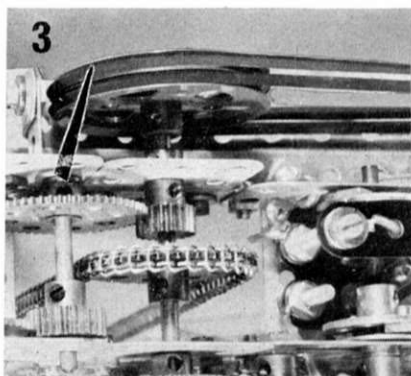

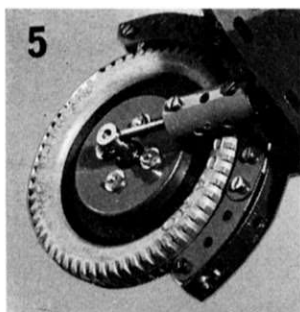

model cranes etc. and it will track on a hollow rail made from Perforated Strips and Angle Girders.

Fig. 4 shows an extension of this idea in which some of the 'disc' type wheels in the system are put to good use. In this case, a Face Plate, Part No. 109, forms a central flange and provides one boss with Grub Screw. Two Wheel Flanges, Parts No. 137 are clamped on either side of the Face Plate using an 8-hole Bush Wheel for extra rigidity. The hollow rail construction can be clearly seen in Fig. 4.

A further use of the Wheel Flange is shown in Fig. 5, where it is used to simulate the drum brake of a model motor cycle. This time, the 3 in. Pulley, Part No. 19b, is employed with the Meccano Motor Tyre supplied to fit this particular size of Pulley. The resulting combination is both neat and realistic.

Constructors who are fond of building vintage road vehicles have employed the 3 in. Spoked Wheel, Part No. 19a, to advantage. In Fig. 7 we can see an early and common use for the Spoked Wheel on the front axle of a model Traction Engine. Because of its smooth rim,

it is not normally thought of as a suitable wheel for rubber-shod vehicles, but it has been used quite successfully in a number of vintage car and lorry models in conjunction with the 3 in. Motor Tyre. However, the Meccano Motor Tyres have central ridges moulded into them so that they locate positively in the Vee grooves of the Pulleys. In order to use the standard Meccano Motor Tyre with the 3 in. Spoked Wheel, it is therefore necessary first to remove this central ridge from the Tyre by means of a sharp-bladed modelling knife.

In many cases, modellers have preserved or inherited some of the earlier Meccano Motor Tyres, many of which have lost a degree of elasticity and have become slightly stretched so that they are no longer a good fit on the original 3 in. Pulleys. Such Tyres are ideal for trimming to fit the 3 in. Spoked Wheels, particularly if the vintage car model is to be exhibited as a

"glass case" model and is not expected to do a great deal of running about. Good Tyres, carefully trimmed, can be made quite a tight fit on the Spoked Wheels and in this case, the model may be run in the normal manner.

Finally, Fig. 8 combines much of what this series has been about so far. The obvious Strip and Girder construction of the rugged base on the model of a French Floating Crane and the use of Flat Plates ties up the first four parts of the series and the neat application of the smaller Flanged Wheels for an elegant roller bearing gives a further application of our Wheels and Axles theme. We shall see these basic essentials occurring again and again through the discourse on various models and mechanisms so that we shall be able to revise and establish the use of Meccano Parts in each succeeding chapter. Part 6 will extend this idea with a discussion on simple gearing.

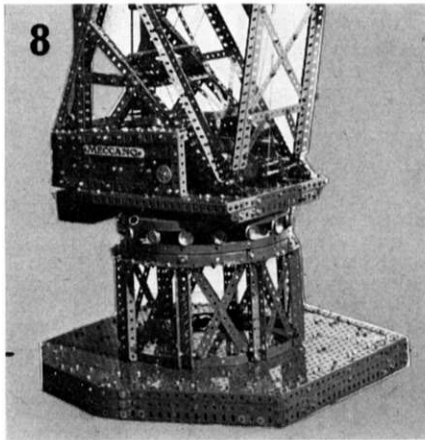
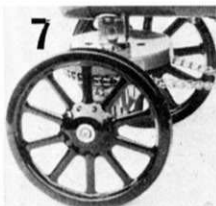
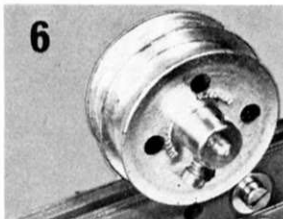

## DINKY TOY NEWS *(Continued from page 225)*

incorporates, like the original, a 3-part telescopic jib fitted with simulated hydraulic rams. The jib is raised and lowered by a positive rack and pinion mechanism, controlled by a knurled handwheel at the left-hand side of the crane body. A ratchet mechanism is included in the movement to ensure that the jib remains in the chosen attitude under load, the ratchet being disengaged for lowering by pulling the control wheel outwards. Its shaft, incidentally, is spring-loaded so that the wheel is automatically pulled in to engage the ratchet, when released.

On the opposite side of the crane body is another knurled handwheel, controlling the load-hoisting cord.

This does not incorporate a ratchet mechanism, but it does include a friction brake which effectively prevents the weight of the load unwinding the cord on its own. In fact, a simple test I have carried out as I write (pulling the cord by hand!) shows that the model will tip over before the cord unwinds without the control wheel being turned.

Thanks to its telescopic nature, the jib itself will extend from approximately 7 in. when closed to nearly 13 in. when fully extended. Extension is achieved by pulling the sections out by hand and care must be taken here that sufficient cord is first run out so that the load hook does not prevent the sections from

being extended. The cord passes down the centre of the jib and the hook will thus foul the jib if the length of "free" cord available is less than the length by which the jib sections are to be extended. For travelling, the closed jib is lowered onto a special support bracket on the cab roof, the load hook being located on another special bracket projecting from the front of the chassis, beneath the radiator-grille. Projecting from the front of the crane body is a simulated spare wheel, incorporated in the body casting, but carrying a removable spare tyre.

As already mentioned, the Dinky is also fitted, like the original, with stabiliser legs to support it during

*(Continued opposite)*

# Meccano Globe-Trotter Competition

Spring  
contest for  
modellers

**S**PRING—the time when a young man's fancy lightly turns to thoughts of love, or so the poet tells us. This Spring, however, our young men might be well advised to lightly turn their fancy away from love, to thoughts of Meccano models. Meccano (1971) Ltd. have recently launched a giant model-building contest which offers a fabulous 1st Prize that no modeller worth his salt will be able to resist having a go at—a trip! for two to almost anywhere in the world, value up to £1,000! In addition, 50 runners-up will each receive a £5.95 Meccano No. 5 Set, or the equivalent in Meccano parts, making a total prize value of nearly £4,000!

Aptly, the contest carries the title "Meccano Globe-Trotter Competition" and we believe it to be one of the most imaginative ever devised for Meccano enthusiasts. Not only is it the first time for Meccano that the winner has been offered an overseas trip, but in this case the winner can, in effect, choose his own destination and we think this is pretty unique for any competition, Meccano or otherwise. It is important to stress, however, that the Globe-Trotter is different from most past competitions in that it carries a *maximum age-limit of 16 years and is open to U.K. residents only*. Anyone under 16 is eligible although there is nothing to prevent parents from helping out their children, particularly with hints and suggestions.

## What to do

The concept of the contest is perfectly simple. All you have to do is to think of somewhere in the world you would like to visit and then build a model associated with that place out of Meccano. Anything appropriate would do, such as a rocket for Cape Kennedy, a Japanese "bullet train" for Tokyo, the Golden Gate Bridge for San Francisco, a typical cruise yacht for

the Caribbean, and so on. The only stipulation on the chosen place is that it must be on or near a B.O.A.C. air route, as the winner will be flown out there in style on a B.O.A.C. Earthshrinker jet, staying in luxury accommodation, with all expenses paid!

The model itself must of course be built out of Meccano parts, although such "extras" as string, paper (e.g. for sails), wood mountings, etc. may be used, provided they represent minor constructional features which cannot otherwise be reproduced with standard Meccano parts. Note, particularly, that size and complexity will not play an important part in the competition. Judging will be based on realism, inventiveness and ingenuity so that a small, well-built model will stand just as much chance as a giant, complicated structure. In principle, however, no limit—maximum or minimum—is placed on the number of parts which may be used, or on the number of entries which may be submitted.

## How to Enter

In entering the competition, it is vital that the rules are correctly followed. Having built the model, a photograph (or photographs) of it must be obtained and this must be sent, along with an official Entry Form and a brief description, to Globe-Trotter Competition, Meccano (1971) Ltd., Binns Road, Liverpool L13 1DA. Under no circumstances may the actual model be sent, although it should be available for inspection in the event of the builder winning a prize. Where more than one entry is submitted, each individual entry must be accompanied by a separate Entry Form.

Another equally vital condition of entry is that the entrant must have purchased, or had purchased for him (or her), Meccano parts to a minimum value of 39p—a Pocket Meccano Set, for instance. To ensure

that this rule is followed, the Entry Forms are available exclusively from Meccano dealers, the dealers supplying a Form only after goods to the qualifying value have been bought. The Form must be stamped or signed by the dealer, in the space provided, to confirm the purchase and it is advisable for every prospective entrant to ensure that this is done.

In the event of a tie for 1st place, the person who, in the opinion of the Judges, gives the best reason for thinking that Meccano is the world's greatest constructional toy, will be declared winner. There will be four judges—Sir Alec Issigonis, designer of the Mini Car and now Advanced Design Consultant to the British Leyland Motor Corporation, Mr. H. J. Fallmann, Managing Director of Meccano, Mr. Michael Riddle, B.O.A.C. Passenger Manager and Mr. Frank Casey, Managing Director of Brunning Advertising and Marketing (Liverpool) Ltd. The judges' decisions will be final on all matters relating to the competition and no correspondence on the subject can be entered into.

## Closing Date

The Meccano Globe-Trotter Competition closes on *30th June 1972* and any entries received after this date will be invalid. All valid entries will be examined, but proof of posting cannot be accepted as proof of receipt and no responsibility can be accepted for entries lost, delayed or damaged before or after receipt. All entries become the copyright of Meccano (1971) Ltd.

Prize-winners will be notified by post after Judging has taken place and a list of winners will be published in the September issue of Meccano Magazine. There will be no need to claim.

Please note that money cannot be given in lieu of prizes.

Happy modelling!

lifting operations. These are located in an upright position for travel, but drop down and lock into the stabilising position for crane work, a rather ingenious "slot-in" system being used for securing them in the chosen position. To get this system right, it is important to carefully follow the instructions packed with the model until the

collector learns the proper way of doing things. It doesn't take long.

Finally, we have the colour-scheme and this, again, closely follows that of the original vehicle with yellow cab, crane body and jib mounted on a black chassis. Yellow diagonal stripes on a black label are carried on the back of the chassis, while the stabilisers, wheel

centres, hook and control wheels are bright-plated. The identification "Coles" in black lettering is labelled on each side of the jib to leave the collector in no doubt as to the make of the full-size original.

Coles cranes are amongst the best of their type in this Country, if not the world—the Dinky Toy, I believe, is the best in the world!

# it's the simple ideas that win!

Right from the start model makers of all ages have risen to the challenge of the Bic Model making competition. The simple but imaginative racing cycle shown below, entered by David Smith of Clifton, Bristol, won first prize in the first quarter of the competition.

Instead of throwing away those used Bic Crystals, model makers have fused them, glued them, bent them and submitted a fascinating assortment of models of all shapes and sizes. Why don't you join in the fun?

Because Bic Crystals write first time every time, there are far more sold in the U.K. than any other ballpen. In fact, each year a Bic Crystal is sold for every man, woman and child in the country plus a few million more.

This is why you will probably find more than you expect in your own home. In offices and factories you should find them by the hundred.

All you have to do . . .  
. . . is start collecting medium or fine used Bic Crystal ballpens now, complete a model and enter the competition.

There are cash prizes for the best models produced every three months both senior and junior. Finally, the supreme modeller at the end of the year will be awarded a further cash prize of £250 and the handsome Bic Championship Trophy.

**If you have a creative flair and a little imagination – prove it!**



**BIC**  
Regd. Trade Mark

model making competition



## Model Making Competition

**Start collecting your pens now but—  
one word of warning—  
make sure they are genuine Bic Crystal Medium  
or Fine Point ballpens carrying the Bic Registered  
Trade Mark because only these are eligible**

### RULES

- The participants of the Bic Model Making Competition will be judged on their originality and technical model-making expertise.
- The competition will be divided into two parts:  
**Junior:** Participants, either sex, under the age of 16 at time of entry. Within this group no heat or flame technique for moulding may be used, but any other form of adhesion may be utilized.  
**Senior:** Participants, either sex, over 16. Within this group, any form of adhesion is accepted. Heat to bend or shape the pens may be used.
- Entries for the competition must be accompanied by the official entry form below.
- Any number of BIC Ballpen barrels may be used. All models must be constructed utilising any part of BIC Crystal Fine (Yellow) and Medium (Transparent) ballpens.
- BIC Crystal barrels may be cut to shape or size, but each barrel must clearly show the Registered trade name BIC (as imprinted on the barrel). Where models are moulded by heat, there must be at least 10 parts where the BIC Registered Trade Mark is clearly shown.
- Accessories other than BIC parts may be used *only* to make the model functional or to infer final design, i.e., wheels, transfers, cotton, string, paper, etc.

### PRIZES

- Prizes will be awarded to competitors who, in the opinion of the panel of judges, produce the most creative, unusual or skilful entry for each quarterly competition.
- Quarterly prizes will be awarded as follows:**  
Senior section—first prize £25,  
second prize £15,  
third prize £10.  
10 consolation prizes of £5 each.  
Junior section—first prize £15,  
second prize £10,  
third prize £5.  
10 consolation prizes of £2 each.
- Models winning any of the three prizes in either Junior or Senior levels of any of the quarterly competitions will automatically be entered in the BIC National Championship Competition and the individual competitor whose model is selected by the judges to be of greatest merit will receive an additional cash prize of £250 together with the 1971 BIC Model-Making Trophy.

### 10 Entrants should send their models to:

**The BIC Model-Making Competition,  
c/o Montague House, 23 Woodside Road,  
Amersham, Bucks.**

Should a model be considered delicate for conventional postage, then a photograph (colour or black and white) may be despatched beforehand. This will be used for preliminary judgement. Entry forms should be clearly attached to each model or photograph entered.

11 No responsibility can be taken for the damage in transportation of any model received. Judges will, however, take into account such unfortunate circumstances and the model will still be eligible for participation within the contest.

12 Should participants require a model returned, then return postage must be included by way of enclosing the appropriate stamps.

### RESULTS

- The 1971 competition will be held during 3-monthly periods and results will be announced during August 1971, November 1971, February 1972.
- Participants should ensure that their models are despatched to arrive by 1st June (for August judging), 1st September (for November judging) and 1st December (for February judging).
- Any model received after this date will not be eligible for the relevant Quarter but will qualify for the next Quarter's competition.
- Any prize winning model will become the property of Biro-Bic Ltd., and may be used in any way they think fit.
- Employees, relatives or direct associates of Biro-Bic Ltd., Model and Allied Publications Ltd., as well as their advertising agents will not be eligible for this competition.
- The decision of the Judges is final and no correspondence can be entered into in relation to prizes awarded or decisions made.

### I understand and abide by the Rules

Name \_\_\_\_\_

(BLOCK LETTERS PLEASE)

Address \_\_\_\_\_

Age \_\_\_\_\_

WHERE DID YOU COLLECT YOUR BIC PENS? \_\_\_\_\_

MM 21

# CLASSIFIED ADVERTISEMENTS

### FOR SALE—PRIVATE

**British Colonial** and foreign stamp collection, offers around £50. Meccano magazines, Sept. 1945–July 1957 and some 1941 and 1944. Offers to Smith, Black Bull Cottage, Fencott, Islip, Oxford. A

**Supermodel** instructions 4, 35 (MM Pages), photocopies 15, 28. Spanish supermodels, Marklin instructions. Offers—Nalty, 101A Normanton Road, Derby. Tel. 361609. A

**150 M.M.'s** 1927 to 1939. Lists available on application. J. Alder, Hawthorn Cottage, Ruscombe, Stroud, Glos. A

**Lesneys Yesteryear** traction engines No. 1, Allchin, No. 9 and No. Y9, Fowler Big Lion. Offers to A. Robinson, 33 Whyke Lane, Chichester. A

**1937 Meccano** Catalogue Reprint, 60p. Also list of old models, send large s.a.e. Acorn Models, 240 Oxford Street, Swansea. A

**Outfit 10** mint condition 4D cabinet yellow/silver. Red/green parts—approx. outfits 9, 7, Mechanisms, Gears "B", Elekrikrit. Motors. 1966 Steam Engine. Numerous facsimile obsolete parts unused, including repro. 167. Numerous parts unused Marklin, Meccano France, Spanish Meccano, Bral, AMI, &c. MM's 1942–date complete, 1956–1960 complete, odd copies late 40's. 50 French MM's. 2 Spanish SML's. Miscellaneous literature: Meccano/GMM—"French & Spanish Meccano Models", MJ No. 1–date, SML copies, &c. Rorke-Giant Block Setting Crane, Gantry Crane, Gearbox &c. plus photos. Konkoly-drawing machines &c. plus photos. The lot £120. Pitt-Evans, The White House, Fairmount Road, Cheltenham. A

### FOR SALE—TRADE

**Arts, Crafts & Pastimes:** New shop opening West Riding, June 1972. All suppliers catalogues and lists to Box No. 59 (Yorks), Meccano Offices, 13/35 Bridge Street, Hemel Hempstead, Herts. A

**Small Electric Motors.** 6V d.c. Body length 60 mm. Diameter, 20 mm. Shaft drive length, 8 mm. Shaft diameter, 2 mm. Unusual speed governor at constant 3,000 r.p.m. (approx.). Ball bearings at both ends. New & unused. 75p each plus 10p post & packing. Harringay Electrical Supplies, 435 Green Lanes, London, N.4. A-F

### EXCHANGE

**Meccano Magazines,** various 1942; 43, 46, 47, for Jan, Feb, July 1944; Jan, Feb, Aug, Oct, Nov, Dec, 1945; Jan, April, July 1966; Feb, March, April, June 1967. R. Brett, 79 Oxford Street, Tawa, New Zealand. A

### WANTED—PRIVATE

**Metal toy soldiers** by Britains Ltd. also their horse-drawn vehicles, trucks, tents, buildings and airplanes. Write E. P. D'Andria—3410 Geary Blvd., No. 343 San Francisco, California 94118. A

**Wanted Dinky Percival Gull,** six wheeled reconnaissance car, searchlight wagon, Cierva autogyro. State price, Selkirk, Officers Mess, RAF Boulmer, Northumberland. A

**Hornby gauge "O" locomotives,** rolling stock and accessories. All letters answered. Duroure, 27 Great Eastern Road, Hockley, Essex S55 4BX. A

(continued overleaf)

## CHEMISTRY

Whether you have just taken an interest in chemistry or you are needing to do a little more practical work in connection with your school studies, A. N. BECK & SONS SCIENTIFIC can supply all your needs. Every item of apparatus is as supplied to Schools and to Professional Laboratories, and there is a range of over 100 chemicals in small packs for home experimenters. Come and visit one of the only specialist shops in the country, where you can see the widest range of apparatus and chemicals available to students. If you are unable to visit the shop, just send a stamped, addressed envelope for a copy of the latest price list.

**A. N. BECK & SONS SCIENTIFIC**  
147 High Road, London, N15 6DQ  
Telephone: 01-800 7342

## PLASTIC CLEAR CASTING

GIANT SIZE  
KIT ONLY



£1.75

Embed coins, flowers, specimens in clear plastic. Kit contains 3lbs clear casting resin, hardener, six special moulds, 1/4lb of colouring pigment (state colour), a measuring syringe, three mixing cups, three sheets wet and dry, 1/2lb tin polishing compound, and illustrated instruction booklet.

MAIL ORDER; cross cheques and P.O.s £1.75 plus 25p. P & P. Strand Glass, Brentway Trading Estate, Brentford, Middx. 01-568 7191.

PERSONAL SHOPPERS  
109 High Street Brentford Middx  
72 London Rd., Southampton.

980 Stockport Rd., Levenshulme, Manchester.

444 Stratford Rd., Sparkhill, Birmingham, 11.

159 St. Michael's Hill, Bristol

All mail order despatched same day with acknowledging postcard. Money back guaranteed if not delighted.

**S** STRAND GLASS BRITAINS LARGEST STOCKIST OF GLASSFIBRE AND RESINS.

## EVERYTHING MECCANO

No. 10 Outfits—All other Sets and Motors  
**CLOCK CONSTRUCTOR OUTFITS**

Kit No. 1—£3.40 plus 21p postage

**STANDARD PARTS 1-235f**

**ELEKTRIKIT PARTS 500-590**

**ELECTRONIC PARTS 602-622**

**WRI REPLICAS PARTS:**

57a 119 156 174

106a SAND ROLLER 127 Simple Bell Crank

also from the same source:

66 50 Gramme Weight 67 25 Gramme Weight

**MW REPLICAS PARTS**

57 HOOK: 172 PENDULUM CONNECTION

9p each—postage extra

"MODEL BUILDING IN MECCANO AND ALLIED CONSTRUCTIONAL SETS"

£1.50 plus 14p postage

"MECCANO CONSTRUCTORS GUIDE"

£1.25 plus 9p postage

"GMM" MECCANO PUBLICATIONS  
MAIL ORDER A PLEASURE—LARGE S.A.E.  
FOR FREE LISTS

Collectors items—Hornby Trains and Dinky  
Toys—Back Numbers "Meccano Magazine"

—BOUGHT & SOLD—

**MW MODELS 165 READING ROAD  
HENLEY-ON-THAMES, Oxon. RG9 1DP  
Tel: (049-12) 3342 E.C. Wednesday**



Short price list of series items. Complete list on request.

### Handbook No. 1 GERMAN SELF-PROPELLED WEAPONS

- Part 1. German-built fully-tracked chassis.  
Part 2. Weapons on foreign-built fully-tracked chassis.

### Handbook No. 2 GERMAN SEMI-TRACKED VEHICLES

- Part 1. Artillery Prime movers, S.P. Guns, Cranes. Each set 40p  
Part 2. Armoured Troop Carriers.

### Handbook No. 3 BRITISH ARMY LORRIES

- Part 1. Tank transporters, recovery vehicles, machinery trucks.  
Part 2. Gun tractors, Bridging Vehicles, Ambulances.

### MILITARY VEHICLE PRINTS Each 25p

Nos. 20-30 20 Pages 9 x 6 1/2 in.

This second series of Armour references in the Bellona MVP range is enlarged with both 1/72 and 1/48th scale views of each listed subject. The fine line drawings are prepared to minute detail perfect for historians and model makers. Photos include rare interior views in many instances. In dispensible for all collectors.

**20** The German Panzerkampfwagen III—late models. Ausf L—1941/42. Ausf M 1942/43; the 7.5 cm 'Sturmpanzer III' Ausf N 1941/42. Ausf M 1942/43; the 7.5 cm tank A13—A13 Mk I/Cruiser tank Mk III (Reworked); A 13 Mk III and IIC5/Cruiser tank Mk IV and Mk IVCS and A13 Mk IVA—IVACS/Cruiser tank Mk IVA—Mk IVACS.

**21** The German tank destroyer—7.5cm PAK 40/2 auf Sfl. II 'Marder' 1942/43 early and late models based on the Panzerkampfwagen II chassis; British 'Tortoise' 1942/47; British light tank Mk. IA—with drawings of the A4E6, A4E7, A4E8, A4E9, A4E10; 1930/35 American Howitzer Motor Carriage T3 based upon the Combat Car M 1, 1939.

**22** American heavy 155mm Gun Motor Carriage M 12 'King Kong' with the GMC T6 prototype and 155mm GMC M 12 production model; Cargo Carrier M30 and the T14 prototype. 1941/44; ISU 122—1944/45 Soviet Assault Gun Motor Carriage ISU 122—D195 and A 25 S versions, 1944/45.

**23** Bundeswehr main battle tank—Kampfpanzer 'Leopard' Prototype I (Group A), Prototype II (Group A), Production Kampfpanzer 'Standard'—Leopard; Recovery and Engineer Vehicles, Bergepanzer 'Standard' and Pionierpanzer 'Standard' 1962/70.

**24** The World War I French Renault FT 17 Fighting tank that shaped the future development of AFV, in service from 1918 to 1945. This most important tank is given detailed coverage. Drawings include the Berliet turret, the normal riveted octagonal turret, with machine gun and 37mm cannon. Also includes version mounting the 75 mm cannon. Drawings and text by Christian Henri Tavaud. The well-known Italian Medium tank Carro Amato M 11/39—1939/41, which was the forerunner of the M 13 40.

**BINDER:** Blue PVC reinforced semi-stiff covers BELLONA MILITARY REFERENCE LIBRARY embossed on spine. Price £1.00 Takes 24 copies on wire retainers.

Add postage 7½p on orders under £1. Orders value £1 and up POST FREE

**MODEL & ALLIED PUBLICATIONS LTD.**  
13-35 BRIDGE STREET, HEMEL HEMPSTEAD, HERTS.  
Telephone: Hemel Hempstead 2501

## CLASSIFIED ADVERTISEMENTS

continued from preceding page

Advise other enthusiasts of your wants and disposals by means of a "classified"

**Meccano Magazine** February 1934, also Military Dinky's No's 621, 622, 623, 641, 693. Please state condition and price. R. Brett, 79 Oxford Street, Tawa, New Zealand. A

**Meccano Clockwork Motors**, gears and brass parts. 133 Russell Drive, Wollaton, Nottingham. Tel: 283095. A

**Wanted.** Hornby and Bassett-Lowke trains, also pre-war catalogues. Reply by return. R. H. Pitts, 18 Beckett Road, Worcester, WR3 7NH. Tel. 0905 53807. Z-E

**Wanted** Pre-1956 Dinky toys and other obsolete Die cast models. Any quantity purchased. Send details, condition and price to: 58 Heathcote Grove, E4 6SB. YZA

**Pre-1940 Toy Cars, Trains, Ships, Money Boxes** wanted. Tim Armitage, Vintage Toyshop, 18 Huddersfield Road, Liversedge, Yorkshire, open Friday, Saturday, telephone Mirfield 4104. ZA

### WANTED—TRADE

**Pre-War** O or I gauge model locomotive and coaches sought, made by Marklin, Bing, Lowke or Hornby, good price paid. Procter, 10 Church Hill, Patcham, Brighton. Tel. 553940. T/C

## BINDERS

In handsome orange book-cloth with gold blocked name plate on spine to take 12 copies of your MECCANO MAGAZINE.

Copies open flat and can be removed unmarked as required.

Price including postage £1.

**MODEL & ALLIED PUBLICATIONS LTD.**  
13/35 BRIDGE STREET,  
HEMEL HEMPSTEAD, HERTS.

**25** The renowned Soviet T.34 Medium tank of 1939 plus the Churchill Bridge layer and the U.S. Armoured Car T.18E2 'Boarhound' provide a trio of famous AFVs with extensively detailed scale drawings plus supplementary views.

**26** Panzerkampfwagen 'Panther' Ausf D and the Befehlspanzerwagen Ausf A in intricate detail plus the Churchills Mk3 III, IV and V with a special insert for this important Bellona Military Vehicle Print in the form of full 5-view 1/48th scale drawings of the Panthers, so permitting space for extra 1/48th scale Churchill views.

**27** The Italian Carro Veloce CV33 plus wireless and flame thrower variations together with the Rolls Royce 1920 Pattern Mk1 Armoured Car as used extensively by the Royal Air Force. The light tank M3A3 'Stuart' Mk V played an important part in the early stages of WWII and is drawn in usual high-class 5-views.

**28** The German half track Leichter Zugkraftwagen 3T—SD KFZ II with its attendant 7.5 cm Panzerjaegerkanon 40 (L/46) fill a long-awaited demand for fine detail on this important vehicle and mobile weapon. Accompanying it is the US Army Combat Car T.7.

**29** The French Char Somua S-35 was the medium tank of the three French Divisions Legere Mecanique (DLM) at the outbreak of the German attack on France in 1940, is extensively detailed, together with the German Sturmgeschuetz IV (L/48) and the Three Ton Special Tractor Ford 3 ton.

**30** The development of the "New Sturmgeschuetz" and "Panzerjaeger Vomag" which plus the Jagdpanzer IV Ausfuehrung F (Sd Kfz 162) and Panzer IV/70 (Sd Kfz 162/I) are fully detailed with technical specification in this 24 page edition.



### THE REPLICA OF ASSOCIATION FOOTBALL

Here is a game where victory or defeat depends upon the skill of the player with fingertip control. COMPLETE with goals, balls and teams available in all League Club colours. Played with 22 miniature men. All the thrills of League, Cup and International Football; dribbling, corner, penalty kicks, offside, goal saves. PRICES £1.20 to £2.70

**NEW SUBBUTEO CONTINENTAL** editions with 00 Scale Teams, hand-painted on duotone coloured bases.  
WORLD CUP £7.90 INTERNATIONAL £6.50  
FLOODLIGHTING £4.90 CLUB £3.50 DISPLAY £1.70

Please ask at your local Sports, Toyshop or Department Store. In case of difficulty write for literature and list of stockists to

## SUBBUTEO

Dept. 5 Langton Green, Tunbridge Wells, Kent.



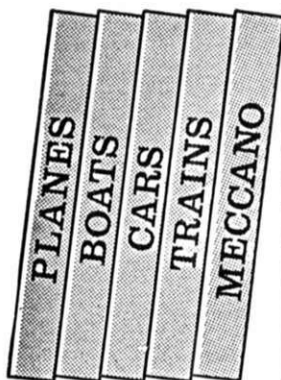

# MODEL SHOP DIRECTORY

**M** denotes Meccano accessory and spare parts specialists

## AYLESBURY

Tel: 85752

**TAYLOR & McKENNA**

46 FRIARS SQUARE

## HEMEL HEMPSTEAD

Tel: 53691

**TAYLOR & McKENNA**

203, MARLOWES **M**

## LEWES

Tel: 3322

**SUSSEX RAILWAY CENTRE**

1 MALLING STREET

EVERYTHING FOR RAILWAYS—N gauge, OO, and O gauge, Hornby, Tri-ang, etc. Military Modelling, Tamiya Kits, Dinky Toys, Lesney, Model cars bought, sold and part exchanged.

## BATH

Tel: 60444

**CYRIL HOWE'S**

CHEAP STREET,  
BATH, SOMERSET

The Model Shop of the West for all your modelling requirements. Aircraft, Boats, Engines, Radio Control. Expert advice available. M.A.P., Meccano Sets, spares, etc.

## HORSHAM

Tel 61533

**MODEL CORNER**

30 NORTH STREET, HORSHAM  
SUSSEX.

Comprehensive range of kits, including Airfix, Tamiya, Revell, etc. Overseas enquiries invited. P & P extra.

## LONDON

Tel: Regent 1846

**JEREMY,**

16 PRINCES ARCADE,  
PICCADILLY- LONDON, S.W.1.  
**MECCANO ACCESSORY AND  
SPARE PART SPECIALIST.** **M**

## BIRMINGHAM

Highbury  
3237

**KINGS HEATH MODELS**

5 York Road, Birmingham 14.

Everything for the modeller: Boats, Cars, Planes, Railways, Kits, etc. Meccano sets and reasonable stocks of spares.

## KENT

Tel: Erith 32339

**DERRETT (TOYS) LTD.,**

52/54 ERITH HIGH STREET,  
ERITH, KENT.

Aircraft, Boats, Fibreglass Hulls, Tri-ang-Hornby, Lima, H.O., H & M., Units, Scalextric, Airfix, Riko, Pactra, Plastic kits, Minitanks, Marquetry. Prompt Mail Order Service.

## LONDON

Tel: 01-560 0473

**RADIO CONTROL  
SUPPLIES**

581 LONDON RD., ISLEWORTH,  
MIDDX. **Mail Order Specialists**

Open each weekday and until  
8.30 p.m. Fridays.

Largest R/C stockists in the country.  
Own R/C service centre.

## BRADFORD

Tel. 44556

**TRAIN SHOP SUPERMARKET**

4 BERTRAM ROAD, BRADFORD 8.

All makes of Model Trains and Motorways Shop Surplus, Bankrupt and Slightly used. Catalogue 1/- Post Free.

**COLLECTORS' MODELS, Matchbox, Dinky, etc.  
WAR GAME FIGURES & ACCESSORIES**  
Minitanks, Hinchcliffe, etc. List S.A.E.

## KENT

Tel. Dartford 24155

**MODERN MODELS LTD.,**

49/51 LOWFIELD STREET,  
DARTFORD, KENT.

For all your modelling requirements. Radio/Control, Aircraft, Boats, Cars, Railways. All leading makes from The Shop with the Stock. Prompt mail order service.

## LONDON

Tel: Mill Hill 2877

**H. A. BLUNT & SONS LTD.,**

133 THE BROADWAY

MILL HILL, LONDON N.W.7. **M**

## CARLISLE

Tel: Carlisle 23142

**PALACE CYCLE STORES,**

122 BOTCHERGATE,  
CARLISLE.

Meccano Stockists for Airfix, Dinky, Matchbox, etc.

## LEEDS, I

Tel: 25739

**BRADFORD MODEL**

**RAILWAY CENTRE,**

23 ALBION PLACE  
(Off Briggate).

The North's Leading Model Railway stockists in OO and N gauges. Branches at Cloth Hall Street, Huddersfield and Frizinghall, Bradford.

## MANCHESTER

Tel: Blackfriars 3972

**THE MODEL SHOP**

7-13 BOOTLE STREET,

OFF DEANSGATE,  
MANCHESTER 2.

THE NORTH'S LEADING MODEL, HOBBY AND TOY SHOP. MECCANO SETS AND SPARE PARTS A SPECIALITY. **M**

**MIDDLESEX**

**Hodgson's Toys & Models Ltd. (MEC)**  
 44/46 Hounslow Rd., Twickenham TW2 7EX.  
 Wide range of Meccano Sets & Accessories,  
 Dinky Toys, Plastic Meccano, Corgi Toys also  
 Model Railways, Boats & Aircraft.  
 Early closing Wednesdays  
 No parking restrictions

**ST. ALBANS**

Tel: Bowmansgreen 2442  
**HOBBIES & SPORTS**  
 5 HASELDINE ROAD,  
 LONDON COLNEY, HERTS.  
 Aircraft, Boats, Model Railways, Wargaming  
 stockists. Comprehensive stocks of Plastic  
 Models. R/C equipment.

**WATFORD** Tel: Watford 44222

**CLEMENTS,**  
**THE PARADE, WATFORD.**

Always a comprehensive range of Meccano  
 Sets, Accessories and Dinky Toys.

**NEW ZEALAND**

**BUNKERS LTD.,**

**P.O. BOX 58**  
**HASTINGS.**

(Mail orders from all countries welcomed.)

**SCARBOROUGH**

Tel: 3223

**"WALKERS"**

**15 ST. THOMAS STREET,**  
**SCARBOROUGH, YORKS.**

**Meccano and Dinky Toy Specialist.**  
 Mail orders welcomed.

**WELWYN**

**H. A. BLUNT**  
**& SONS LTD.**

**38 FRETHERNE ROAD,**  
**WELWYN GARDEN CITY, HERTS.**  
 Complete range of model aircraft, engines  
 and accessories, boats, cars and railways.

**READING** Tel: Reading 51558

**READING MODEL SUPPLIES**

**5 Chatham St. Car Park, Oxford Road,**  
**READING, BERKSHIRE.**  
**BERKSHIRE'S MODEL CENTRE**  
*You can drive right to us.*

**STOCKTON-ON-TEES**

Tel: 67616

**LESLIE BROWN**

**95 HIGH STREET,**  
**STOCKTON-ON-TEES, TEESIDE ST518BD**  
 Super Toy and Model Store. Meccano Range  
 and Spare Parts. Mail Orders welcome.

**WORLD WIDE**

coverage assured by a regular  
 insertion in this directory  
 For full details write to:  
**MECCANO MAGAZINE**  
**13-35 BRIDGE STREET**  
**HEMEL HEMPSTEAD**  
**HERTS**

**MODEL RAILWAYS**

Gresley's "Great Northern"—the first of his many 'Pacificals'—went into service 50 years ago this March. John Edgson, the well-known locomotive modeller, commemorated this event by building a super-detailed replica of 1470 to 4 mm. scale. How he tackled construction is revealed in a two-part feature to be read in Model Railways (superstructure—April issue; chassis and running gear—May issue).

Thoughts on the combustion of various fuels in small locomotives is another side to the coverage offered by "M.R.", the magazine which aims at stimulating the most essential equipment for any hobby—the imagination.

**MODEL RAILWAYS**

published the second Friday every month at 20p is a product of

**MODEL & ALLIED PUBLICATIONS LTD**  
**13/35 Bridge Street, Hemel Hempstead, Herts.**

**MECCANO**

Excellent stocks and By Return, World wide mail order, from one of the countries leading specialists.

**WE STOCK**

Sets 1 - 10

Spares 1 - 235f

All motors, special sets and add on sets.

S.a.e. for lists. P. & P. free over £5 (U.K. only).

Sets only tax free for export

**JOHN W. BAGNALL LTD.,**

**18 SALTER STREET,**  
**STAFFORD**

Est. 1936

Tel: 3420

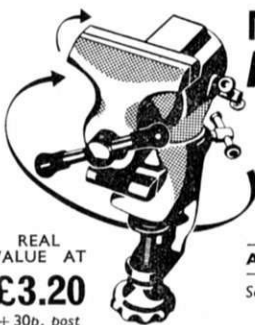

REAL  
 VALUE AT

**£3.20**

+ 30p. post  
 C.W.O.

**MULTI-ANGLE  
 ALL PURPOSE VICE**

VEE JAWS—VERTICAL AND HORIZONTAL FOR BETTER GRIP

Twin 2½" & 1½" jaws. Rotates 360°

Lock in any position.

Head rotates 360° and locks.

Silver blue hammer finish.

EASY CLAMPING OR SCREW FIXING

**A MUST FOR ALL MODELLERS**

Sent by return with our money back guarantee

**D. GLOVER** (Dept. ME3)

203 Scholes Lane, Cleckheaton, Yorks.

**TESTORS**

**KEILKRAFT**

# Silver Wind Trainer

£10.49



Two beautiful ready-to-fly control liners, one in gorgeous red and white trim, the other in an all-over gleaming silver finish.

Almost unbreakable! Rubber band assembly allows parts to separate on impact without breakage.

Stable flight—so stable that even the most inexperienced pilot can learn to fly with these models.

Versatile—controls can be adjusted to make the plane an aerobatic trainer.

Unbreakable nylon propeller—cushion-action landing gear with wheel spats.

£9.68



Big 22½" wingspan  
21½" fuselage.

A most comprehensive Instruction Manual is included, also control line and handle.

Powered by  
McCOY .049  
engine



# Cosmic Wind Trainer

AVAILABLE AT **KEILKRAFT** AGENTS

# NEW DINKY POWER!

**CLOSE DOWN HATCHES!**



**ROCKET FIRING POWER**



With flip-up hatch and revolving rocket-firing platform!



## SHADO 2 Mobile

- Flexible tracks
- Moulded seats and windows

Model No. 353

FROM GERRY ANDERSON'S TV SERIES

# UFO

**SHADO 2 - DEVASTATING FIRE POWER TO DESTROY THE ALIENS!**

**DINKY ACTION KITS**

**NEW**



**BUILD IT YOURSELF!**



## The racy VOLVO 1800S

- Opening doors
- Opening bonnet
- Opening boot
- Folding seats

Model No. 1002

**PAINT IT YOURSELF!**

## ZOOMING-SPEEDING POWER!

### MATRA 630

- Opening bonnet revealing detailed engine
- Moulded interior and seats
- Deep-set twin headlights



Model No. 200

WITH SPEEDWHEELS



leaders go for **DINKY TOYS**  
the tough, action-packed models