

MECCANO[®]

Magazine

22½p

QUARTERLY

Vol. 59 No. 2 MECCANO MAGAZINE FOUNDED 1916

April 1974

BETTER LATE...

IT WILL NOT have escaped the notice of readers that the last MMQ was dreadfully late. Thankfully, the majority of you understood the reason for this, but for the benefit of those who didn't, as well as for overseas readers, I feel some explanation is due.

The fact is that the delay was entirely beyond our control. At the time the last issue was prepared, Britain was in the throes of an industrial dispute which resulted in industry being allowed to use electricity on only three days a week. This meant that we were able to work fully on only the three 'power' days as the type-setter, plate-maker and printer rely on electrically-operated machines and we, of course, need light.

This in itself was enough to delay the Magazine, but in our case, the situation was even worse: we were allowed power for the first half of the week; the type-setter and plate-maker for the second half! The implications are obvious. In producing the Magazine, the various articles and pages pass back and forth between ourselves, the type-setter and the plate-maker several times as the various production stages are reached. Because of the different working days, any material we passed to the others, say, at the beginning of the week could not be actioned until the Thursday at the earliest. Equally, anything they passed to us in the latter half of the week could not be processed here until the following Monday. Thus, over the various stages, the delay was cumulative, with the result that the January issue was so very late. But better late than never!

M. E. CUP WINNER

Our heartiest congratulations go to Mr. Michael Martin of Ilford, Essex, for winning the Meccano Cup at this year's Model Engineer Exhibition, held in London at the beginning of the year. His winning model was a giant steam-driven Block-setting Crane (see photo above), based on two actual crane illustrations in a 1929 M.M. All movements operate authentically, with power coming entirely from a Meccano Steam Engine.

The M.E. Exhibition is organised annually by Model & Allied Publications Limited and, regrettably, it was not made clear that there was a Meccano section in the Exhibition this year. *Would you believe we didn't even know!* However, we will monitor the situation on your

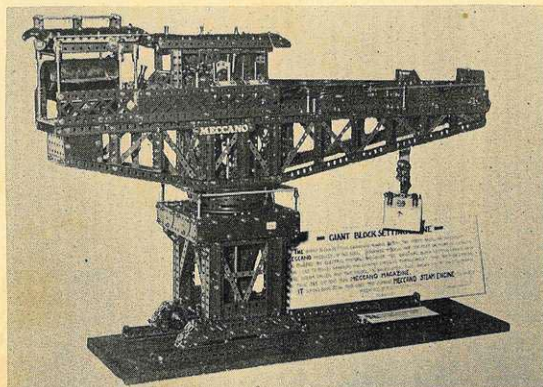

M.E. Cup-winner: Giant Block-setter by Michael Martin

behalf for next year and will let you know the facts in plenty of time. A big Meccano entry would be fine.

PAST MASTERS

Reading through this Magazine, you will see that we have not included a 'Past Masters' feature. Reason: we had too many other things to fit into our limited space this issue – besides, because of the already-mentioned 3-day week, we did not have time to build and describe a suitable offering! We hope to have something for you in July, however, so please bear with us.

MOGUL

Also included in the July issue will be a short review of a brand new product line – Mogul Steel Toys – which was shown at the Brighton Toy Fair in January and which will be on sale later in the year. Mogul are the first large-scale, custom-made steel toys to be produced by Meccano Limited and, although they do not fall into the Meccano constructional system, they will be of interest, not only as a new Company product, but also because three of the initial range of vehicles have been specially designed to receive add-on sections built out of Meccano! Meccano has many uses you know ...!

The Editor

EDITORIAL DIRECTOR: J.D. McHard

EDITOR: C. J. Jelley

ASSISTANT EDITOR: M. K. Peddie

PUBLISHED FOUR TIMES PER YEAR IN
JANUARY, APRIL, JULY AND OCTOBER

CONTENTS

- | | |
|------------------------------|---------------------------|
| 30. Hydraulic Alligator | 40. Full-size Beach Buggy |
| 32. Collectors' Corner | 42. Digital Clock |
| 34. Among the Model-Builders | 46. Dinky Toys News |
| 37. Mobile Trolley Crane | 47. Moon-drive Mechanism |
| 38. Meccano Miscellany | 48. Meccano Club Roundup |

SET 5 MODEL . . SET 5 MODEL . . SET 5 MODEL

Hydraulic ALLIGATOR

'Spanner' describes a model of a Belgian Metal-shear

YES! BELIEVE IT or not, this model is based on a machine which is actually called a "Hydraulic Alligator!" Before anybody starts thinking that we are advocating the construction of the latest thing in fiendish mechanical monsters, however, I hasten to explain that it is not the star of a bloodthirsty horror film, but an industrial shearing machine used for cropping metal. The particular original on which our model is based is a Lefort C.600mm. Shear as manufactured by the Lefort company of Gossiels, Belgium. It is a modern, mobile machine with its own built-in power unit to make it totally independent of all Mains supplies.

Our Model, of course, is meant only as a representation, but it is

nonetheless pretty accurate in overall outline and, most important, it reproduces the main "jaw-snapping" motion of the original. It is built from the contents of a No. 5 Meccano Set, with power for the jaw motion being supplied by a Magic Clockwork Motor. The chassis is built up from a 5½" x 2½" Flanged Plate 1 (flanges pointing downwards), to the centre of the forward flange of which a 2½" x ½" Double Angle Strip 2 is rigidly attached by one lug. A 2½" x 1½" Flanged Plate 3 is bolted to the other lug of this Double Angle Strip.

Bolted to one side flange of Plate 1 is a 5½" x 2½" Flexible Plate 4 extended five holes forward by a 5½" x 1½" Flexible Plate 5. Note that

the upper edge of the latter Flexible Plate is overlaid on the inside by a 5½" Strip 6. The forward ends of both the Strip and the Plate are secured to the nearby flange of Flanged Plate 3.

Secured to the other flange of Plate 1 is a 6" x 2½" compound flexible plate, built up from one 2½" x 2½" Flexible Plate 7 and one 4½" x 2½" Flexible Plate 8. The compound plate is also extended five holes forward by a 5½" x 2½" Flexible Plate overlaid along its upper inside edge by a 5½" Strip, the Strip and the Plate again being bolted to the remaining flange of Plate 3. It will be found that the rear end of the compound plate projects one hole past the rear end of Plate 1 and it is then further extended by a 2½" x 1½" Flexible Plate 9 and a 2½" x 1½" Triangular Flexible Plate 10, arranged as shown, the securing Bolts helping to fix a vertical 2½" Strip 11 to the inside of the Plates. The Strip projects one hole above the Plates. A horizontal Fishplate 12 is bolted to the top of the Strip, the securing Bolt passing through the elongated hole of the Fishplate. A 2½" x 2½" Flexible Plate 13 is bolted to the centre of Flexible Plate 8 in such a position that this also projects one hole above the top of the Plate.

Returning to the opposite side of the model, the upper rear corner of Flexible Plate 4 is connected to Flexible Plate 8 by a 2½" x ½" Double Angle Strip. Bolted between this Double Angle Strip and the rear flange of Plate 1 is a 2½" x 1½" Plastic Plate 14, the lower securing Bolt also holding a Trunnion 15 in place. Bolted to this Trunnion are a 2½" x 1½" Triangular Flexible Plate 16 extended upwards by a 2½" x 1½" Flexible Plate, both overlaid by a vertical 2½" Strip corresponding with Strip 11. As before, a horizontal Fishplate 17 is bolted to the upper end of the Strip to align with Fishplate 12. The rear corners of the 2½" x 1½" Flexible and Triangular Flexible Plates are connected to the rear

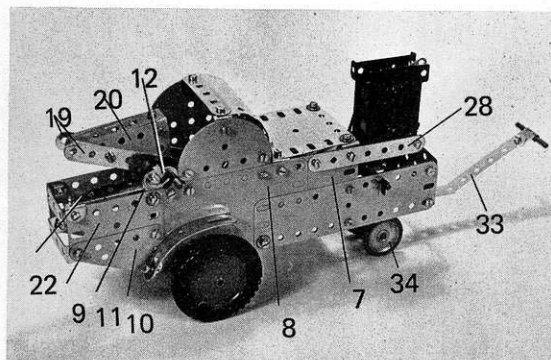

This model (left), built from a No. 5 Set, is based on the full-size Lefort C.600 mm. Shear pictured below. The comparative realism of the model is clearly evident. Although Lefort is a Belgian company, our photo is reproduced by kind permission of Vanesco Ltd., of Morden, Surrey — sole British agents for Lefort.

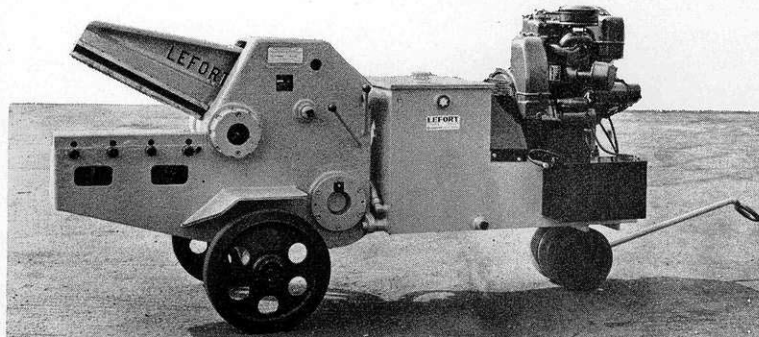

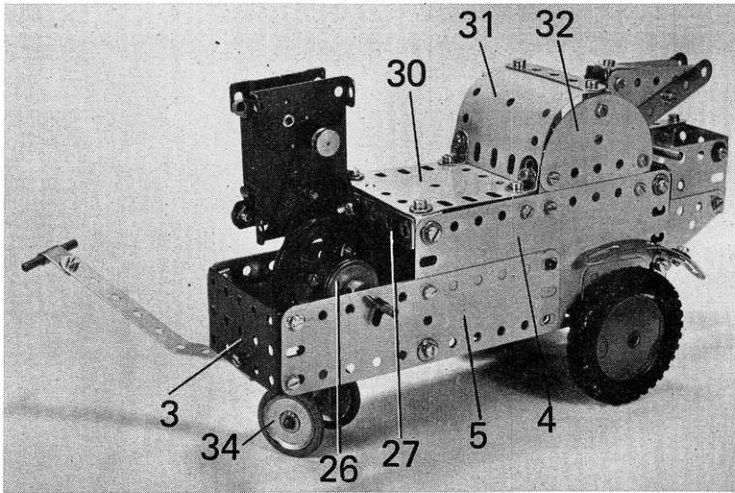

Hydraulic Alligator – not the latest thing in fiendish mechanical monsters, but a powerful metal-shearing machine! Our model will not actually cut, of course, but it is a good reproduction which goes through the motions, powered by a Magic Motor.

corners of Plates 9 and 10 by two $1\frac{1}{2}$ " x $\frac{1}{2}$ " Double Angle Strips 18.

Journalled in the circular holes of Fishplates 12 and 17 is a $3\frac{1}{2}$ " Rod which serves as the pivot for the cutting jaw. This is simply built up from two $5\frac{1}{2}$ " Strips 19, connected together through their third holes from the rear by a Double Bracket, the securing Bolts also fixing two $2\frac{1}{2}$ " x $1\frac{1}{2}$ " Triangular Flexible Plates 20, one to each Strip. The upper corners of the Plates are connected together by another Double Bracket, to the back of which a $2\frac{1}{2}$ " Strip 21 is bolted. Another $2\frac{1}{2}$ " Strip 22 is attached by Angle Brackets to the top of Flexible Plate 9.

Now lock-nutted through the second hole of the forward end of right-hand Strip 19 are two Angle Brackets 23 arranged to form a built-up double bracket. Journalled in the lugs of the double bracket is a 2" Rod carrying a $\frac{1}{2}$ " fixed Pulley on its upper end and a Rod and Strip Connector on its lower end. The Rod and Strip Connector is free to revolve on a lock-nutted Bolt held in one hole in the face of an 8-hole Bush Wheel 24, fixed on the inner end of a 2" Rod which is journalled in the apex hole of a Flat Trunnion (bolted to Flanged Plate 1) and in the centre hole of Flexible Plate 4. A 1" fixed Pulley 25 is also carried on the Rod, this being connected by a crossed-over 10" Driving Band to a 1" Pulley 26 fixed on a 3" Rod journalled in the upper fourth holes of Flexible Plates 5 and Strips 6, where it is held in place by Spring Clips. A 2" Pulley also fixed on the

Rod is connected by a 6" Driving Band to the output pulley of a Magic Motor bolted to a $2\frac{1}{2}$ " x $\frac{1}{2}$ " Double Angle Strip 27, secured between the upper forward corners of Flexible Plates 4 and 7. An additional securing point is supplied by a $3\frac{1}{2}$ " Strip 28 bolted to Plate 7, as shown.

Note that the Bolts fixing Double Angle Strip 27 to the Flexible Plates also hold Angle Brackets in place. Attached to these Angle Brackets and to another $2\frac{1}{2}$ " x $\frac{1}{2}$ " Double Angle Strip 29, bolted between the upper fifth holes of the Flexible Plates, is a $2\frac{1}{2}$ " x $2\frac{1}{2}$ " Flexible Plate 30. This is extended, via Angle Brackets, by a $2\frac{1}{2}$ " x $2\frac{1}{2}$ " Curved Plate 31, the upper end of which is overlaid by a $2\frac{1}{2}$ " Strip and bolted to a $2\frac{1}{2}$ " x $\frac{1}{2}$ " Double Angle Strip which is in turn bolted between two Semi-circular Plates 32. One of these Semi-circular Plates is bolted to Flex-

In this high view of the Alligator, the upper plating has been removed to show the jaw-movement control mechanism. Note that double bracket 23 is built up from two Angle Brackets, fixed together and lock-nutted to the nearby $5\frac{1}{2}$ " Strip. Drive is transferred from the Motor by Driving Bands and Pulleys.

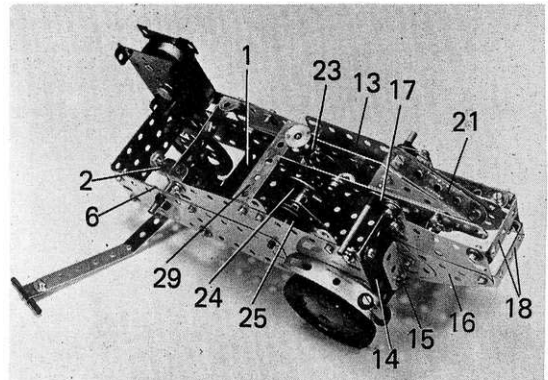

ible Plate 13, while the other is bolted to Fishplates which are in turn attached to the upper edge of Flexible Plate 4.

The jockey wheels and handle are next simply built up from a 1" x $\frac{1}{2}$ " Double Bracket, lock-nutted to the centre of Double Angle Strip 2, the lock-nutting Bolts also fixing a $5\frac{1}{2}$ " Strip 33 between the lugs of the Double Bracket. This Strip is bent to shape, as shown, and its forward end is extended by a right-angled Rod and Strip Connector in which a $1\frac{1}{2}$ " Rod is held to serve as the handle. Another $1\frac{1}{2}$ " Rod is journalled in the end holes in the Double Bracket lugs, where it is held in place by 1" fixed Pulleys 34, fitted with Rubber Rings. The main wheels are simply $2\frac{1}{2}$ " Road Wheels on a $3\frac{1}{2}$ " Rod journalled in the apex holes of two Flat Trunnions bolted to the sides of the model. The finishing touch is then provided by two main wheel mudguards, each supplied by a Formed Slotted Strip attached to the relevant Flexible Plate 4 or 8 by an Angle Bracket.

When the Magic Motor is run, the jaws of the model should snap open and shut in a realistic manner. Needless to say, of course, the model will not actually cut anything, but it nonetheless makes a very interesting construction!

PARTS REQUIRED

5- 2	1-20a	1- 51	3-190
1- 3	4-22	1- 52	1-191
5- 5	1-23a	1-111c	1-192
4-10	1-24	2-126	1-194
2-11	5-35	2-126a	1-200
1-11a	77-37a	2-155	1-212
10-12	71-37b	2-186a	1-212a
3-16	18-38	2-187	2-214
2-17	2-48	2-188	2-215
2-18a	5-48a	2-189	4-221
1 Magic Clockwork Motor			

COLLECTORS' CORNER

by B. N. Love

"PRIMUS" ENGINEERING

MODEL RAILWAY rolling stock has been manufactured on a grand scale since the beginning of the century and one coach more or less hardly seems significant. However, the item shown in Fig. 1 below is a pretty rare bird because of its age and unique method of construction.

Just over half a century ago when Meccano had already reached an advanced stage and was being pirated by rival manufacturers overseas, a U.K. firm distributed a constructional system known as Primus Engineering. The first two illustrations show little evidence of any similarity to Meccano and the reader would be forgiven for assuming that the model was basically a wooden construction. No doubt the original manufacturers had this in mind and they made their wooden parts in an ingenious manner so that they were easily assembled and versatile enough to be interchangeable to a degree. These parts had a mahogany-like appearance with a fairly coarse grain and the finish on them was a little crude in places. It is obvious that hand labour was involved to a considerable degree and, as the outfits were made for the toy trade and hence had to be competitive, a fineness of finish was understandably lacking. The sample shown in Fig. 1 has been restored a little by judicious use of various grades of glasspaper and a transparent liquid wax polish.

If we consider Figs. 2 & 4 the similarity to Meccano as the basic constructional elements becomes apparent

The heading illustration above, showing a completed railway coach, is reproduced from an original Primus Engineering manual of 50 years ago. Below left: Fig. 1, the author's completed version and, below right, Fig. 2, general construction showing sliding section and hinged door.

Model No. 254.

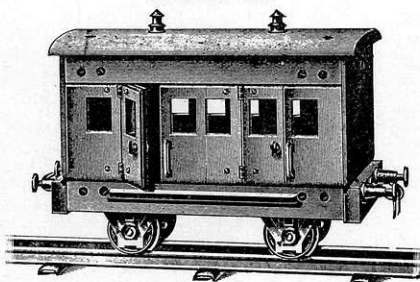

but there are various differences as follows. Eagle-eyed readers will have spotted the slightly different design of bent trunnions supporting the wheel axles, while the flanged wheels themselves have eight holes apiece whereas their Meccano equivalents have only four holes. Less noticeable are the $6\frac{1}{2}$ " perforated strips and angle girders forming the upper and lower sections of the framework, this size of strip and girder having never been listed as a Meccano item. Hole size and spacing is identical with that of Meccano and, to complete the restoration for photographic purposes, two of the four upright $3\frac{1}{2}$ " strips were replaced by early Meccano Perforated Strips in their original nickel plating. The original Primus strips were very badly rusted as were the buffers and axle rods.

The ingenuity of the system lay in the fact that all of the wooden parts could be attached *after* the truck framework has been assembled. The constructor could therefore build his model in skeleton form, complete with wheels, as a working model before adding any of the wooden components. The secret lies in having two types of holes in certain of the wooden parts. The coach ends and side rails had $\frac{1}{4}$ " holes drilled right through so that they could be located over the heads of bolts already securing the metal framework. A second set of holes in the wooden components were recessed half way with a $\frac{1}{4}$ " dia. and then reduced to the fit of the bolt shank, so that bolts inserted here would fix the

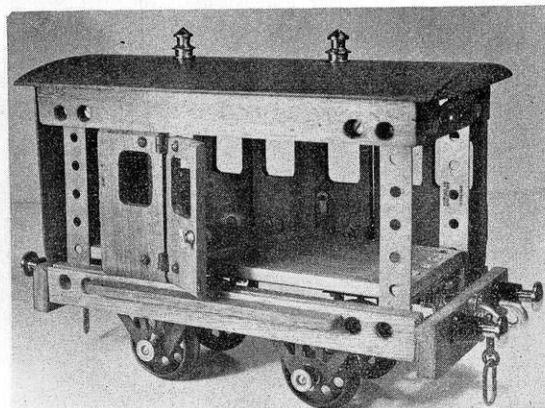
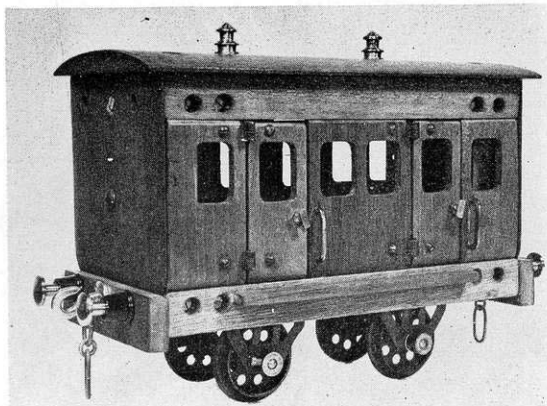

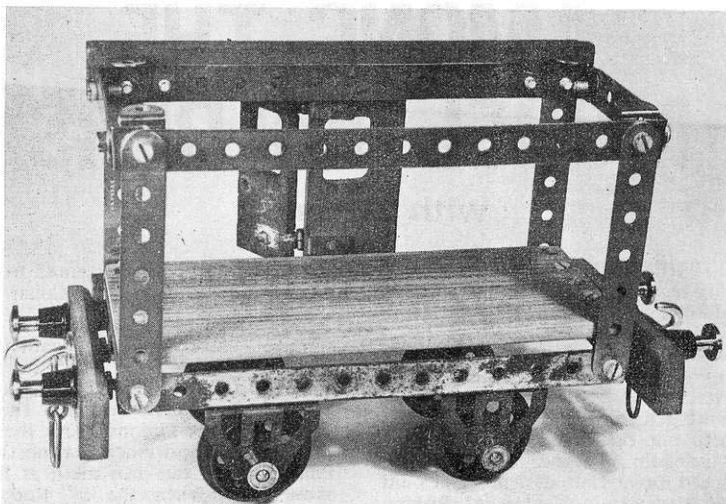
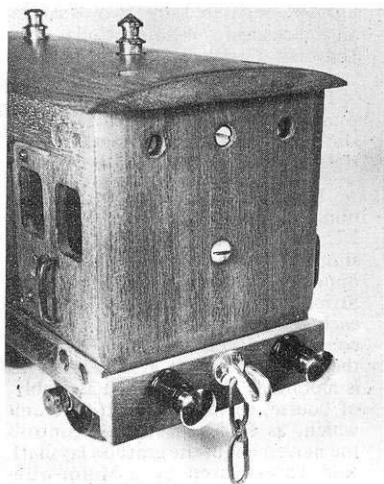

Above left: Fig. 3 showing close-up view of pre-formed wooden parts secured to inner metal framework by recessed bolts. Above right: Fig. 4, basic framework showing striking resemblance to Meccano parts.

wooden parts to the strips etc. Corner assemblies were completed with $\frac{1}{2}$ " x $\frac{1}{2}$ " angle brackets, very similar to Meccano parts, but in a slightly thicker gauge of steel. Nuts and bolts had an identical thread with their Meccano counterparts, but certain anomalies were found in Primus Outfits. Their original bolts were slightly longer and not very convenient at the corner assemblies where they tend to foul each other inside the angle brackets. In addition, wheel bosses and the narrow collars used in the Primus system had a tapped hole of 6BA size thread.

Instruction manuals included in Primus Outfits showed various models of railway trucks and motor lorries in which a coach end doubled up as the roof of the lorry cab, etc. Fig. 2 shows the passenger coach construction in which the door sections could be slid into place between upper and lower vee grooves cut into the wooden side rails. Hinged floors were provided, these being cut slightly shorter than the sliding sections so that they could be swung open. Again, a further change in screw size was employed for the door hinges and latches, these being 8BA size in plain brass.

The buffer beam, illustrated in Fig. 5, carried a substantial draw-hook in brass and generous sized buffers in steel. These latter were very rusty at the time of acquisition, but after a good spinning in the lathe or electric drill chuck against some coarse and fine emery they were restored to a bright lustre, while the buffer cylinders were provided with a coat of glossy black enamel. The roof ventilators received similar polishing and these, like the buffers and draw-hook, had standard threads similar to Meccano although in general scale they are much larger components than their contemporaries in Meccano. Fig. 6 shows the view from below with the peculiar squared-off ends of the $6\frac{1}{2}$ in. angle girders. Readers may also note that one axle rod is secured by Primus Collars and the other by Meccano Collars for comparison.

Similar models, or pieces, still survive to-day in various collections of old toys, bric-a-brac, trunks in attics, etc. and some variations will be found such as polished brass for ventilators and buffers instead of bright steel, but this all adds interest to establishing the lore of yesterday's toys and to-day's treasurers.

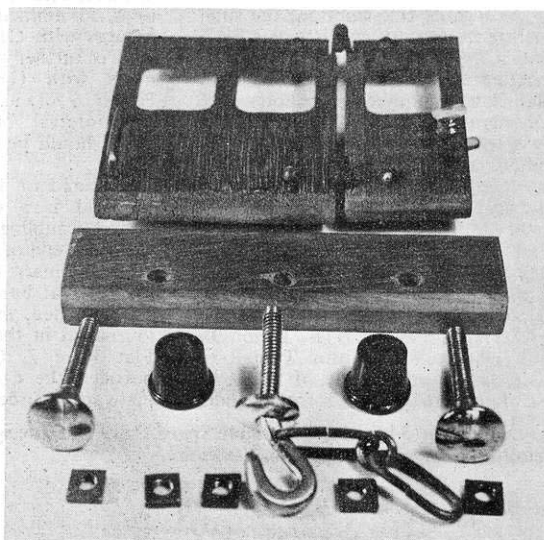

Above: Fig. 5, buffer beam and components of Primus Engineering Passenger Coach. Hooks and buffers have $\frac{5}{32}$ " BSW thread as for Meccano. Below: Fig. 6, underside view of Coach showing Primus flanged wheels and trunnions. Note squared-off girder ends and narrow collar on axle.

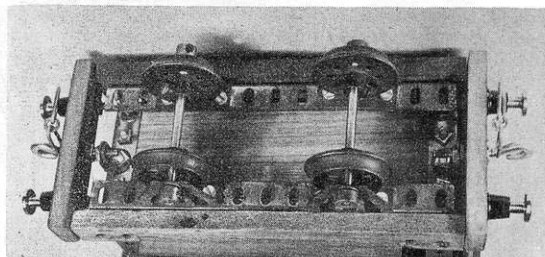

AMONG THE MODEL BUILDERS

with "Spanner"

WHEN SETTling down to write this regular feature, the temptation often is to waste the first paragraph or two on general "idle" chatter — which I must admit I thoroughly enjoy. In this issue particularly, however, space is at a premium, so I must get straight down to business with our first contributed item: an Automatic 3-speed and Variable Speed Drive Unit designed and built by Mr. Harold Taylor, of Birkby, Huddersfield, who has been a valued friend of Meccano Magazine for very many years.

As regards construction, the supporting framework consists of a 9½" and a 7½" Angle Girder connected together at one end by a 5½" x 2½" Flat Plate 1, the securing Bolts also holding a 2½" Angle Girder in place. Two more 2½" Angle Girders are bolted, as shown, between the first two Girders, then three 1½" x 1½" Flat Plates 2, 3 and 4 are bolted one each to the vertical flanges of each of the 2½" Angle Girders. Journalled in the top centre holes of Plates 3 and 4 is a 5" Rod carrying, in order between the Plates, a ¾" Pinion 5, a ½" Pinion 6 and a 7/16" Pinion 7. A 1" Pulley with Motor Tyre 8 is fixed on the outer end of the Rod and note that the Rod is free to slide

in its bearings, being prevented from excessive movement by a Collar 9.

Journalled in the centre holes of the 2½" Angle Girders beneath the 5" Rod is a 3½" Rod which carries a 50-teeth Gear 10, a 57-teeth Gear 11 and a 60-teeth Gear 12. These Gears, and the Pinions above them, should be so positioned that no two Pinions and Gears can mesh at the same time. When the 5" Rod is moved as far outwards as Collar 9 will allow, Pinion 7 should mesh with Gear 12. Then, when the Rod is slid inwards, Pinion 6 should mesh with Gear 11 immediately Pinion 7 disengages with Gear 12 and, when the Rod is further slid, Pinion 5 should mesh with Gear 10 immediately Pinion 6 disengages with Gear 11. The interval of neutral between gears should be as short as possible.

Secured on the inner end of the 5" Rod is a Collar, on which a Socket Coupling 13 is held. Fixed in the other end of this Socket Coupling is an ordinary Coupling 14, in the longitudinal bore of which 4½" Rod 15 is carried, free. This Rod is also journalled in the top centre hole of Flat Plate 2. Carried on the Rod between the Coupling and the Flat Plate are, in order, three Compression

Springs, separated by two Washers, an electrical 4-hole Collar (or Universal Coupling "spider") 16 and three Washers. Note that the Collar is fixed on the Rod, the Rod being prevented from sliding in Plate 2 by another Collar on the other side of the Plate.

Lock-nutted through two opposite bores of Collar 16 are two 1½" Strips 17, another two 1½" Strips 18 being similarly lock-nutted through two opposite bores of Coupling 14. The Strips are arranged as shown, then each pair of Strips are pivotally connected together by a ¾" Bolt, on the shank of which a ½" Pinion 19 is mounted. The completed assembly, of course, serves as a centrifuge unit which, as Rod 15 revolves, controls the movement of the gearbox layshaft. Rod 15 is driven by a Motor-with-Gearbox, bolted to Flat Plate 1, a 1" Pulley on the motor output shaft being connected by a 10" Driving Band to a 1½" Pulley 20 on Rod 15. At slow speeds, the action of the Compression Springs on the Rod hold the mechanism in low gear. However, as speed increases, the centrifuge comes into operation and draws the layshaft inwards, thus causing the higher gears to be engaged.

The friction drive feature of the mechanism is taken from Pulley-with-Motor Tyre 8. The Pulley simply makes contact with a Face Plate 21 on a Rod journalled in a 2½" x 2½" Flat Plate (bolted to the outer end of the 9½" framework Angle Girder) and in a Double Bent Strip bolted to the back of the Plate. Note that a Compression Spring is carried on the Rod between the Face Plate and the Flat Plate to hold the Face Plate in contact with the Motor Tyre. In operation, as the centrifuge unit varies the position of the gearbox layshaft, the position of the Pulley with Motor Tyre on the Face Plate is also varied.

An Automatic 3-speed and Variable Speed Drive Unit, designed and built by Mr. Harold Taylor of Huddersfield, Yorkshire.

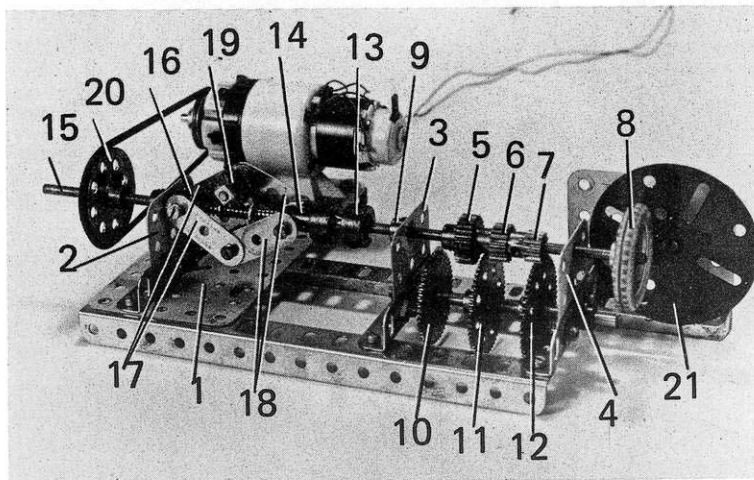

PARTS REQUIRED

4- 6a	1-21	1-27d	1- 70
1- 8a	2-22	28-37a	1- 72
1- 8b	1-25	24-37b	3- 74
4- 9d	3-26	5-38	1-108
2-15a	1-26c	1-45	1-111
1-16	1-27	7-59	4-120b
1-17	1-27a	1-63	1-142d
			1-171
1 Motor-with-Gearbox			1-186c

MAGIC LIGHT

On a totally different subject, now, I would like to draw attention to the first diagram reproduced here. This is re-drawn from an original

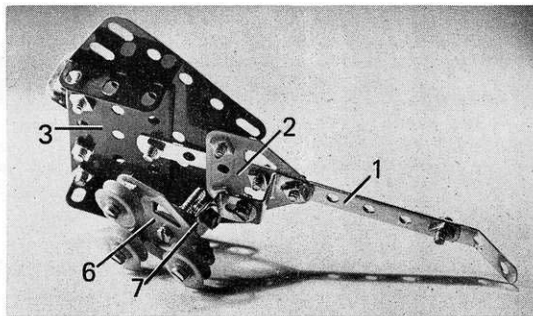
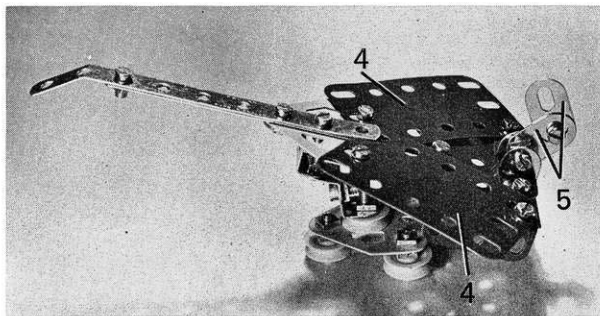

Two views of a miniature model of 'Concord' built from a Pocket Meccano Set by Mr. Roger Le Rolland of Stoke-on-Trent, Staffs. Although very simple, the basic arrow shape of the famous Anglo-French aircraft is easily recognisable.

plan submitted by Mr. Don Blakeborough of Ngaio, Wellington, New Zealand and it gives all the information required to build a light-hearted "fun" model to mystify the children.

"Some time ago", explained Mr. Blakeborough. "I built up entirely in Meccano what I called a Magic

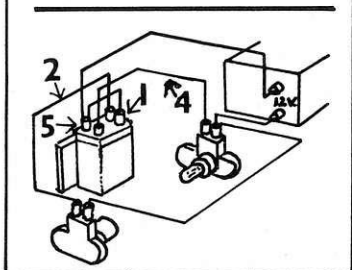
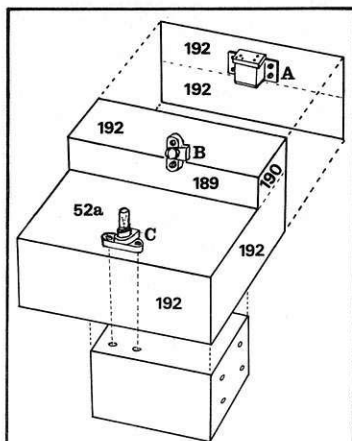

Light which has fascinated many of my friends and mystified many children. It is very simple to construct, using only a few standard parts, plus the Meccano Electronic Control Set. The "Magic" light can be lit by placing a lighted match (or torch) near the bulb; take the match away, and the light will stay on! To extinguish the light, just cover the bulb

with your fingers and the light will go out!

"To anyone watching, it would appear that the light from the match "jumped" into the magic bulb and that it was extinguished by being pinched out". (It's magic! Ed.)

The actual operation, of course, depends on the Photo Cell and the Relay in the Electronic Set. As Mr. Blakeborough explained in his letter, the match or torch shining on the Photo Cell activates the Relay which, when wired in the circuit shown in the diagram, switches on the Lamp. The light from the Lamp then takes over from the match and, by shining on the Photo Cell, keeps the circuit open to remain lit. When the light is apparently pinched out, the fingers in fact break the light beam to the Photo Cell and thus switch the circuit off. It's a simple idea, but put to an entertaining use. Construction, as mentioned, is evident from the diagram, although the various Plates must of course be fixed together. This can be achieved by Angle Brackets, or by bolting the Plates to a suitable Girder framework.

BI-STABLE SWITCH

Still on the subject of Electronic Control components, I have received a suggestion on a way of using the

components to produce an interesting Bi-Stable Switch. The idea, shown in the accompanying diagram, comes from Mr. A. Farina of Torino, Italy and I felt that it could prove very useful in various Meccano models. Purely by way of an example of just one use, however, Mr. Farina has supplied a description of it fitted to a grandfather clock where it provides the controlling switch for a motorised automatic re-wind feature.

"A Photo Cell, with Hood, and a Lamp (Part No. 608)," he writes, "are located in the clock-case so that the driving weight cuts the light beam from the Lamp to the Cell as soon as the rewinding is finished. In the bottom of the clock-case, a push-button type of switch (for instance, made from a Part No. 543 and a Part No. 532 such as Model No. E2 in the 4EL Set Manual) is located directly under the weight so that the weight, when fully down, presses on the switch and closes the electrical circuit to bring the winding motor into action".

POCKET CONCORD

Moving on to the miniature scene, next, the Secretary of the Stevenage Meccano Club, Mr. Dennis Higginson,

OVER →

Above left: diagram showing construction of a 'Magic Light' designed by Mr. Don Blakeborough of Wellington, New Zealand. A = Relay; B = Photo Cell; C = Lamp. The wiring arrangement appears in the lower diagram. Right: wiring diagram showing use of Electronic components to provide a Bi-stable Switch, from an idea by Mr. A. Farina of Torino, Italy. A = power source; B = push-button switch; C = Relay; D = Lamp; E = Photo Cell; M = Motor.

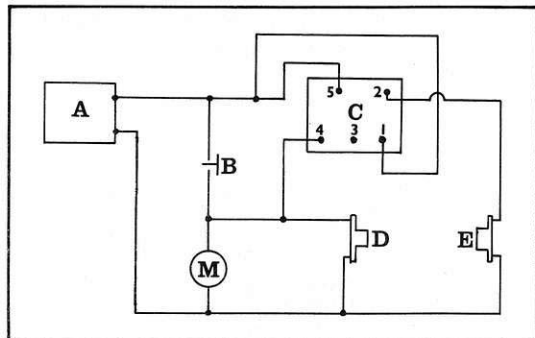

recently sent me details of a Pocket Meccano model based on the Anglo French Concord aircraft and it appealed to me so much that I felt it well worth including here for the benefit of young readers. The model was designed by Mr. Roger Le Rolland, who is a member of the S.M.C. and who has the special knack of being able to "knock up" tiny, yet very realistic constructions. Indeed, examples of his work have been featured in these pages in the past and a glance at the accompanying illustrations will show that his Concord is well up to standard.

Construction is easy. The fuselage consists of two 4½" Narrow Strips 1, overlapped three holes, with the fixing Bolts also holding a Flat Trunnion 2 in place. A 2½" x 1½" Flanged Plate 3 is bolted to the rear end of rear-most Strip 1, then bolted between this and the base corner holes of Flat Trunnion 2 are 2½" x 1½" Plastic Plates 4, angled as shown to represent the wings. The inner front corners of these Plates are also sandwiched in the overlap between Narrow Strips 1. The fin is built up from two Fishplates 5, arranged as shown and held by Nuts in the centre of a ½" Bolt held by further Nuts in the spare lugs of two Angle Brackets bolted to the rear edge of Flanged Plate 3. Narrow Strips 1, of course, serve as the fuselage and the front end of the forward Strip is bent down slightly to represent the "droop snout" of the real-life aircraft.

An effective display stand for the model is provided by a Flat Trunnion 6, in the corner holes of which three ½" Bolts are held by Nuts, a ½" loose Pulley being held on the shank

of each Bolt by further Nuts. Fixed to the centre of the Trunnion by a ¾" Bolt is another ½" Pulley and an Angle Bracket 7, the spare lug of this Angle Bracket being extended by an Obtuse Angle bracket. Bolted to the spare lug of this Obtuse Angle Bracket is a Double Bracket, the other lug of which is bolted to the underside of Concord.

MORE ABOUT THAT. . . DIFFERENTIAL ANALYSER

In the October issue of the MMQ you may remember we featured a "real" Differential Analyser which had been built in the 1930's and which had recently come to light in New Zealand. At the end of the item I asked if any readers had any more information, but I must admit I had little hope that, as the machine was built so long ago, any replies would be forthcoming. You can imagine my surprise – and delight – therefore, when I received a most informative letter, full of interesting facts, from Mr. S. Barcroft, an engineer living in Havant, Hants. Mr. Barcroft actually worked on one of the original machines under the direction of its designer and I am very pleased to be able to publish his letter below:

"Your brief article (writes Mr. Barcroft) on the Meccano Differential Analyser in the October issue was of special interest to me. I have pleasant memories of working with one of these machines in the Ministry of Supply at the Air Defence Research and Development Establishment (A.D.R.D.E.) Malvern, Worcs., in

about 1942 under the direction of Dr. A. Porter, whom you referred to as being the first person to build one from Meccano parts. The Malvern machine, I believe, had originated with Doctor Porter in his earlier days at Cambridge University so this was quite possibly the original version regarding which you are now seeking information.

"My job as a Laboratory Assistant at that time included the maintenance and operation of the Differential Analyser; having been a great Meccano enthusiast in boyhood I found the work extremely enjoyable.

"The entire machine was laid out on the frame of a four-legged table about 10' x 4' x 3' high. The main non-Meccano parts were:

1. Intergrator discs – plate glass.
2. Intergrator wheels – steel, ground to a knife edge.
3. Torque amplifiers had chromium-plated capstan drums and fabricated brass torque-arms for the input and output shafts. The first stage input shafts ran in dual bearings and were carefully balanced. The driving cords of the capstans consisted of finishing twine for the first stages and cat gut for the second stages.
4. The right-angled drives from intergrators to bus-shafts were 1:1 helical brass gears in one-piece brass housings which floated on the interesting shafts.

"I recall an amusing incident when Mr. S. K. Runcorn (now Prof. Runcorn of Durham University) was using the Differential Analyser to solve one of his problems. In leaning too far over the machine, his University tie became trapped between a pair of spur gears with the result that his head was slowly, but relentlessly being hauled in the machine! The computation had to be interrupted while I extracted him with the aid of a screwdriver, his tie by this time having collected a greasy set of teeth marks over much of its length!

"I'm afraid I don't know what became of this machine subsequently, but it could easily have ended up at the Science Museum. These machines were, of course, the forerunners of present day analogue computers. Digital computers had their origin (with Babbage?) much earlier".

I am indebted to Mr. Barcroft, not only for his very interesting letter, but also for his permission to reproduce it here. (The accompanying sketches, by the way, have been re-drawn from Mr. Barcroft's originals).

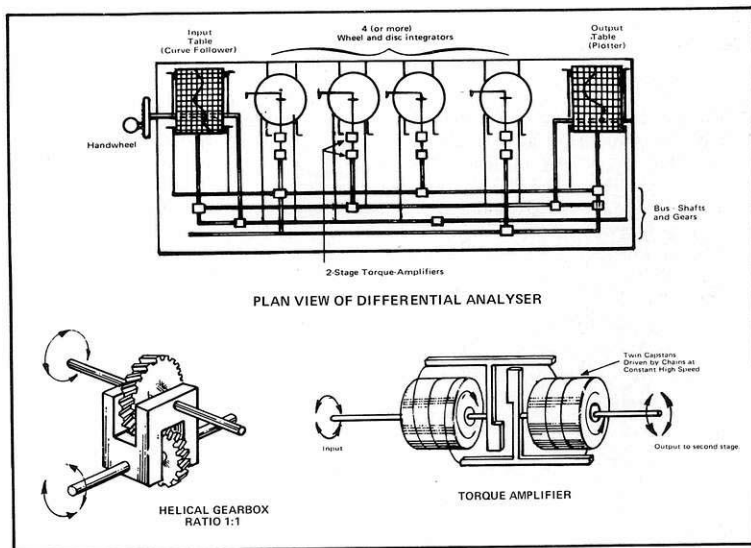

SET 1 MODEL .. SET 1 MODEL .. SET 1 MODEL

Mobile Trolley Crane

by 'Spanner'

IF ANYBODY had asked me, I would have said that every conceivable type of crane had at some time been featured in model form in the pages of Meccano Magazine – or I would have said so before I saw the model pictured here! This one is new to me. It's a Mobile Trolley Crane, based on a type we use in the factory at Binns Road for lifting heavy machine tools and, to the best of my knowledge, we have not featured such a model before (Meccano historians will no doubt be able to prove me wrong!) It is built from a No. 1 Set and construction is not difficult.

Two Trunnions 1 are bolted to the underside of a $5\frac{1}{2}$ " x $2\frac{1}{2}$ " Flanged Plate, the securing Bolts also fixing four Angle Brackets to the top (inside) of the Flanged Plate. Bolted to the spare lugs of these Angle Brackets are two horizontal $5\frac{1}{2}$ " Strips 2, two upward-pointing $5\frac{1}{2}$ " Strips 3 and two $2\frac{1}{2}$ " Strips 4, arranged as shown. The upper end holes of Strip 4 coincide with the fifth holes of Strips 3, but note that, instead of the Strips being bolted together, the holes serve as the journals for a $3\frac{1}{2}$ " Crank Handle 5 which is held in place by Spring Clips. The upper ends of Strips 3 are extended by two $2\frac{1}{2}$ " Stepped Curved Strips 6 which are locked together at their upper ends by three Nuts on a $3/8$ " Bolt.

A distance of $\frac{1}{4}$ " should separate the ends of the Curved Strips and this is achieved by passing the Bolt through the first Strips, adding two Nuts to the Bolt, passing the Bolt through the second Strip and then adding the third Nut. The first Nut is locked against the first Strip; a space is left between the first and second Nut, then the second Strip is locked between the second and third Nuts. A length of Cord is wrapped around the appropriate part of the shank of Crank Handle 5, the end being run over the jib-head Bolt and fitted with a Wire Hook.

Turning to the jockey wheel assembly, this is built up from two $2\frac{1}{2}$ " x $\frac{1}{2}$ " Double Angle Strips 7, fixed together by their lugs to form a box shape. Note that the inner securing Bolt also fixes a Double Bracket by one of its lugs inside the inner end of the box. Now bolted to

each side of the box are a $2\frac{1}{2}$ " Strip 8 and a Flat Trunnion 9, and note particularly the unusual angle of the Flat Trunnion: the outer securing Bolt does not pass through one of the round holes in the Trunnion, but through one of the large main holes and then through the lower hole in Strip 8. The inner securing Bolt, however, does pass through the round corner hole of the Flat Trunnion, with the result that the Trunnion is angled upwards, as shown. Journalled in the apex holes of the Flat Trunnions at each side is a 1" Rod on which an 8-hole Bush Wheel 10 is fixed, between the Flat Trunnions, to serve as the jockey wheel, itself.

Strips 8 are angled as shown and a 2" Rod 11 is held by Spring Clips in their upper end holes to serve as the jockey handle. The completed assembly is then pivotally attached to the Flanged Plate by a $3/8$ " Bolt which is passed up through the earlier-mentioned Double Bracket and through the Flanged Plate, where it is lock-nutted in place.

The main wheels are provided by two 1" Pulleys, fitted with Motor Tyres, which are mounted on a $3\frac{1}{2}$ " Rod journalled in the apex holes of Trunnions 1. The real machine, incidentally, is moved about from place to place by hand, but the actual lifting winch is powered by an electric motor. On our model, this motor is simply represented by two curved $2\frac{1}{2}$ " x $1\frac{1}{2}$ " Plastic Plates 12, overlapped one hole and bolted between Strips 2. Although they cannot be seen in the photographs, the securing Bolts also fix Fishplates in position

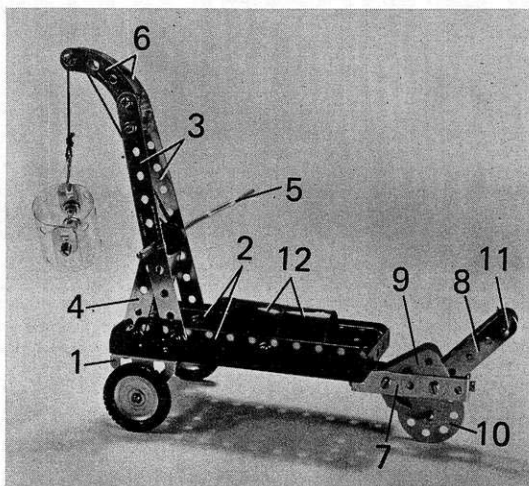

inside the Plates to help hold the Plates against the Strips.

This, then, completes the model, but, to use up a few more parts in the Set, we provided a demonstration "load". As can be seen, this is built up from two $2\frac{1}{2}$ " x $1\frac{1}{2}$ " Transparent Plastic Plates, bolted together to form a cylinder, with two opposite securing Bolts also holding two Fishplates in place. We thought the load added a nice finishing touch to a very interesting little model!

PARTS REQUIRED

4- 2	1-18b	23-37b	2- 90a
4- 5	1-19s	6-38	2-111c
4-10	2-22	1-40	2-126
1-11	1-24	2-48a	2-126a
4-12	4-35	1-52	2-142c
1-16	28-37a	1-57d	2-193
1-17			2-194

Illustrated here and in the photograph above is a Mobile Trolley Crane based on a type used in the Meccano factory. It is built from a No. 1 Set.

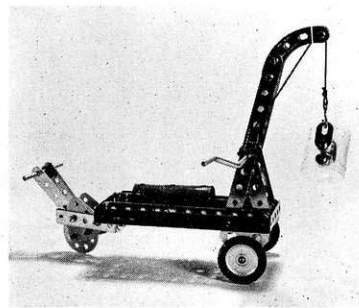

MECCANO MISCELLANY

by MIKE NICHOLLS

Electronic Control

Many people have asked me just what the Meccano Electronic Control Set will do for them, so I would like to devote the first part of this feature to an answer to this question.

First of all, we must understand what is meant by the word 'electronics'. It is a much-used, but little-understood word. To most people it means masses of tangled wire, printed circuits and computers, but these are only by-products of the (so-called) 'electronic age' in which we live.

Electronics is the science of ELECTRONS and their practical uses. Electrons are one of the smallest particles

known to man; they are the tiny 'satellites' that orbit the nucleus of the atoms of which all matter is composed. However, I will not go into detail about the principles of the atom and of electricity (this subject is covered in depth in "The Junior Meccano Engineer" No. 3); it will be sufficient for our purposes here to say that electricity 'flows' due to the atoms of a conductor *passing on* electrons rather like a row of firemen passing buckets of water to each other down the line.

That is the *science* of electrons, but what of their *practical uses*?

There are three main effects of electricity that are used to advantage in our everyday lives:

1. The *Heating* effect (electric fires, kettles, etc.)
2. The *Magnetic* effect (coils, motors, etc.)
3. The *Lighting* effect (lamps)

The first and second effects are closely related, but only the lighting and magnetic effects are used in Meccano modelling.

Everyone is familiar with the lighting effect of electricity, whereby the filament of an electric lamp is made to light up as electrons flow through it at sufficient pressure. The pressure is provided by a battery (or other means) which 'pumps' the electrons round the circuit in a similar way to that in which a water pump causes water in a pipe to circulate. Disconnect the battery (pump) and the flow of electrons stops and the light goes out. This simple circuit is shown in Fig. 1.

The magnetic effect of electricity is well known to those model-builders who have used the Meccano Electrical Parts. When a current is passed through a *Coil* the Coil becomes magnetic, and a *Core* placed inside the Coil becomes a powerful magnet. In Fig. 2, a Coil has been placed close to the switch of the circuit that we had in Fig. 1. If switch 2 is now closed, the current flows through the Coil which becomes magnetic and pulls switch 1 shut. We now have the position shown in Fig. 3. The coil and switch 1 together form a *Relay*.

A relay is a *magnetically-operated switch*. The Electronic Control Set Relay (Part 606) contains a switch that is able to pass electrons in a sufficiently high volume to operate Meccano Coils (Parts 520, 522 or 614) or a Meccano motor. The important point about the Meccano Relay is that it requires very little electron flow to operate its switch.

The Meccano Photo-Electric Cell (Part 602) is also a switch. It contains a small piece of cadmium sulphide (CdS) which is a chemical substance that will not participate in our flow of electrons unless a light is shone upon it. It is as if one of the firemen in our line refuses to work in the dark! The Photo-Electric Cell is

This is the first in a regular series of articles by Mike Nicholls who is Editor of "The Junior Meccano Engineer" and leader of the Henley Society of Junior Meccano Engineers. Mike's articles will cover a wide variety of subjects, as he tells us he is likely to touch on almost anything of interest to the Meccano modeller - and that leaves a lot of scope!

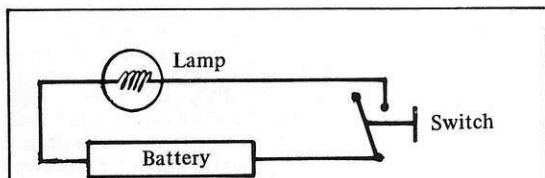

Fig. 1

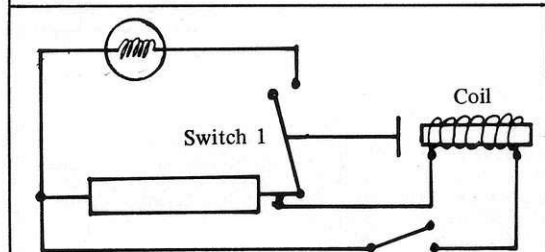

Fig. 2

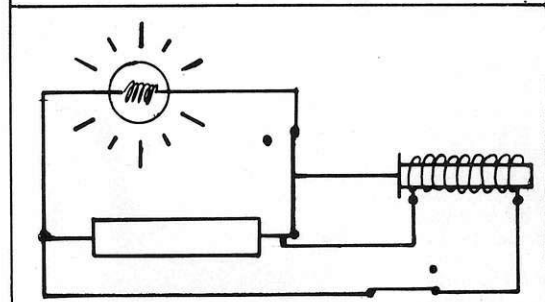

Fig. 3

therefore a *light-operated switch*. However, the Cds is not capable of passing electrons at a high volume, but it will pass a sufficient volume to operate the Meccano Relay, so, with the arrangement in Fig. 4, we have a 'low-volume' light-controlled circuit operating a 'high-volume' circuit. Note that the Photo-Electric Cell can only be used in conjunction with the Relay.

On the base of the Meccano Relay the sockets are numbered 1 to 5. These sockets correspond to our circuits as shown in Fig. 5. It will be seen that sockets 1 and 2 are the ones to be connected to the 'low-volume' or 'sensing circuit'. Socket No. 5 is the 'common' pole of the Relay's switch, and one of the 'high-volume' circuit's wires is always connected to this socket. In our diagrams we have always connected the other 'high-volume' wire to socket No. 4, so that, when the Photo-Electric Cell is illuminated, the 'high-volume' circuit is completed and the Lamp (or Motor) works. If we connect the wire to socket No. 3 however, it is obvious that the Lamp or Motor will work only when the light to the Photo-Electric Cell is *interrupted*. In this way we can switch *on* OR *off* by interrupting the light.

That, then, is what the Electronic Control Set will do for you. It will enable you to control models with a light beam. The possibilities of this cannot be stated better than in the opening paragraph of the Electronic Control Set Manual:

"Just as electronics in real life enable scientists to build better, more sophisticated machinery than would otherwise be possible, so the special electronic components ... enable you to build better, more sophisticated models when used with existing Meccano parts".

One of the reasons why Meccano is still popular after 73 years is that the parts in the system are in themselves abstract. They may be built into models to reflect the design trends of any period. A boy in 1920 would build models in the style of 1920, just as modellers using the same parts in the 1970's build models that reflect the designs of the Space Age.

This unique versatility of Meccano parts is brought to mind dramatically by the model shown in Figs. 6 and 7, which uses the latest Multikit parts to represent a vehicle built for use in the first world war! The model is the work of Kim Fisher, a member of the Henley Society of Meccano Engineers, and I am indebted to Kim for the photographs of, and information on the tank.

The original MK1 Tank (known affectionately as "Mother") was built by a Lieut. Wilson and William Tritton at the Foster Works early in 1916. The shape of the lower track approximated to an arc of a 60 foot (18m) diameter wheel which allowed it to cross trenches up to 8 feet (2.5m) wide, and mount parapets 4 feet (1.2m) high. To limit the height and keep the centre of gravity low, the guns were placed in sponsons, one on each side of the vehicle. 150 MK1 tanks were built and were first used on September 15, 1916 at the battle of Flers-Courcelette.

The trailing wheels were designed to assist steering and trench crossing, but in fact became quickly bogged down in the mud in France or were shot away! They were not incorporated in later tanks.



The Super Highway Multikit announced in the January MMQ sees the introduction of four more

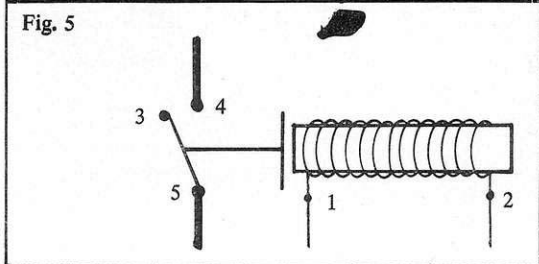
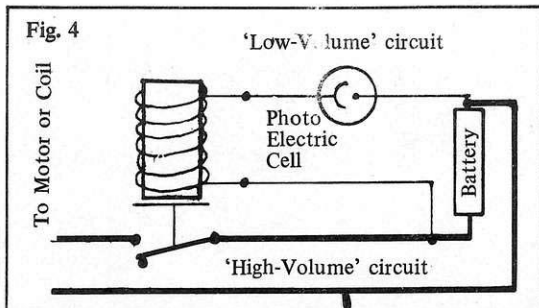

standard parts in "Highway colours", these are as follows:

- Part 335 Formed Slotted Strip (as 215) Yellow.
- Part 336 Angle Bracket 1/2" (as 12) Brass Plated.
- Part 337 1-1/8" Bolt (as 111d) Brass Plated.
- Part P98 Small Plastic Sprocket Wheel (as P84) Red.

In addition, the original set of "Highway" Stickers has been extended in this outfit, and carries the part number 334.



Talking of Meccano parts, did you realize that there are 466 different spare parts to the Meccano range? What a system!

Fig. 6

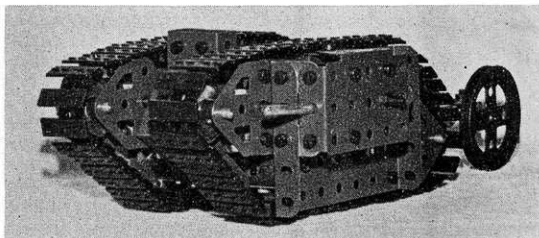
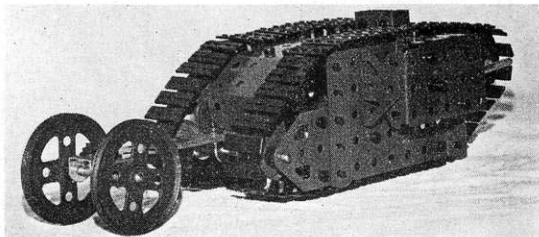

Fig. 7





REGULAR READERS of Meccano Magazine will know of the fabulous demonstration models made in Meccano by the Father and Son team, Giuseppe and Gianguido Servetti of Italy. Indeed, those readers who attended the Henley Meccano Exhibition last summer will have seen an example of their work at first hand – the full-size motor scooter which also featured on the front page of a recent MMQ. If you thought the scooter was amazing, though, then hold on to your hats: the Servettis have now produced a full size Motor Car! It comes in the shape of a “Beach Buggy”, constructed throughout in standard Meccano parts with the exception of the four tyres, sparking plugs and distributor lead wires.

Looking at our heading photograph (Fig. 1), which shows the Buggy in a realistic outdoor setting, those readers who are familiar with the general outlines of a

Fig. 1 above: No! Not trick photography, but a life-size Beach Buggy built by the Servettis of Italy. Below: a frontal view taken at the Brighton Toy Fair.



Trick Photography ?
Or is this really a

FULL - SIZE CAR IN MECCANO

Beach Buggy either from seeing one ‘in the flesh’ or by reference to various scale models, will be impressed by the fidelity of reproduction. Not only does the model look full-size, it will also accommodate the weight and proportions of two people. The photo (originally taken for publicity purposes) shows a couple of youngsters, but it will easily take two full-grown adults! Additional pictures shot by Bert Love at the Brighton Toy Fair in January show something of the detail which the Servetti genius has incorporated in the model.

Fig. 2 shows the general frontal view of the Buggy where its generous proportions and styling are clearly illustrated. The headlights are fully functional, being made from Circular Girders in a Flexible Plate fairing and utilising standard Meccano Electrical Lamp Holders on Wheel Flanges for illumination. Wheel camber and independent four-wheel suspension is faithfully modelled and working disc brakes are featured all round!

Tail-end features (see Fig. 3) are equally well reproduced, the whole of the rear panelling being hinged for opening to reveal a highly detailed simulated air-cooled Volkswagen 4-cylinder engine which is open-vented to atmosphere as shown in the picture and as exists in the prototype. Eagle-eyed readers will have spotted a lorry cab pressing from the Highway Multikit serving as a tail-lamp housing unit. This is fitted with three Lamp Holders on either side of the car at the rear to provide a red tail lamp, an amber flashing direction indicator (working authentically from the steering column flip-switch) and a further red stop light connected to the foot brake pedal switch.

Wheel construction to hold the full-size, real-life tyres makes use of sets of Large-toothed Quadrants secured to double-thickness 6” Circular Plates by Flanged Sector Plates and Perforated Strips, giving a genuine likeness to the ‘spoked’ alloy wheels commonly found on sports cars today. Fig. 4 gives the ‘inside story’ of the wheel construction where large Flanged Rings and Flat Trunnions are used to hold the tyre beading. Note the telescopic simulated independent suspension. Some of the engine details are also shown in Fig. 4, notably the cylinder radial cooling fins built up from many spaced layers of Curved Strips.

The Servetti ingenuity is further illustrated by the use of a plastic Road Wheel from a Multikit set as the head

of the ignition coil and by the use of a large Plastic Meccano Gear Wheel for the distributor head. Standard Insulated Bushes form the ignition lead insulators.

Fan, fan belt and generator are also neatly modelled in the engine compartment and the moving parts one would expect to see on the original engine come to life when the model car is started. This procedure follows the normal practice and readers are referred to Fig. 5 which shows the neat side fairing, the leather-clad seats, working hand brake, gear-lever, steering wheel and dashboard. Fitted to the right-hand side of the dashboard is a small glove compartment with pull-open flap and inside is an ignition key made from a Slotted Coupling and a 1" Corner Bracket with Grub Screws fitted strategically. The dashboard 'keyhole' for the ignition key is formed from an inverted Wheel Flange on the dash and this can be seen in Fig. 5 through the spokes of the steering wheel. When the ignition key is turned, all the electrical circuits are "opened" ready for use. Then, press a starter button on the dash, and the 'engine' springs into life! It runs at tick-over speed, but, when the foot pedal accelerator/ is pressed, the engine speed increases and is accompanied by the appropriate increased engine-revving noise simulated by a simple Plastic Plate 'soundbox' mechanism in the engine compartment.

Not content with the degree of realism already achieved, the Servettis built in a bowden drive rev. counter (on the left of the steering wheel) which operates a swinging pointer as the revs. pick up!

Hand brake and gear-lever are also included and of appropriate size and appearance, the hand brake lever running up one Large-toothed Quadrant with disengaging pawl controlled by a thumb button at the top of the lever. Plastic Meccano parts make up the gear-lever which moves in a realistic manner. Further bowden drives (Meccano connecting wire in Spring Cord) operate disc brakes all-round from the foot brake pedal. The 'discs' are 6" Circular Plates and the 'pads' are Wheel Discs which straddle the Circular Plates. Seating employs Braced Girder-work on adjustable slides, a plastic type leather-cloth being bolted to the framework in the interests of realism and passenger comfort!

A rear-view mirror and working windscreen wipers are included and, as the Servetti Beach Buggy is of Continental origin, it is naturally fitted with left-hand

drive. The final touch of authenticity is provided by an Italian Road Fund Licence attached to the windscreen!

Between them, Giuseppe and Gianguido built the Buggy in less than 100 working hours, which is no mean feat considering its size and complexity. It uses more than 12,300 parts, including Nuts and Bolts, and measures some 7'3" long by 3'8½" wide by 3'4" high. Weight is in the region of 250 lb. The Beach Buggy is not, of course, a road-running machine - being mounted clear of the floor on a sturdy plinth - but its detail and working mechanisms represent an outstanding achievement in Meccano.

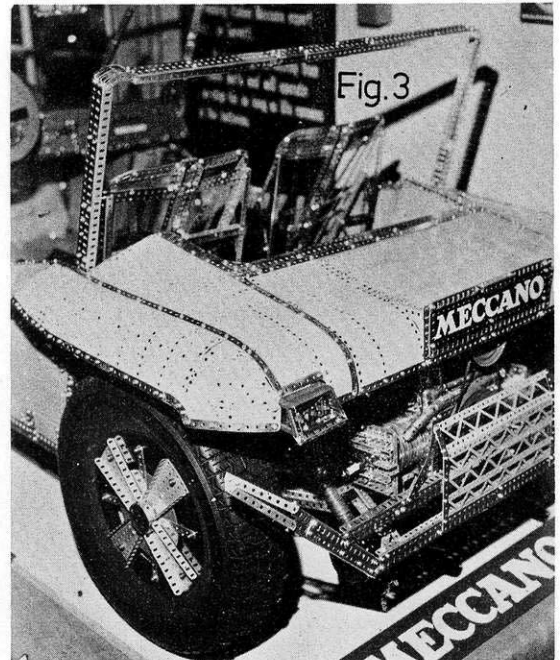
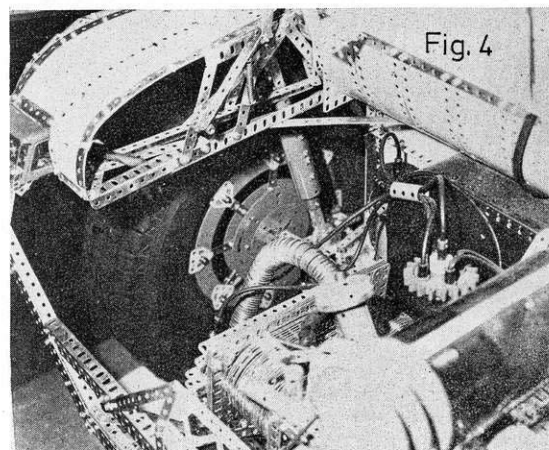

A close-up view of the rear of the Beach Buggy. Note the use of a Multikit Cab for the rear light console.

drive. The final touch of authenticity is provided by an Italian Road Fund Licence attached to the windscreen!

Between them, Giuseppe and Gianguido built the Buggy in less than 100 working hours, which is no mean feat considering its size and complexity. It uses more than 12,300 parts, including Nuts and Bolts, and measures some 7'3" long by 3'8½" wide by 3'4" high. Weight is in the region of 250 lb. The Beach Buggy is not, of course, a road-running machine - being mounted clear of the floor on a sturdy plinth - but its detail and working mechanisms represent an outstanding achievement in Meccano.

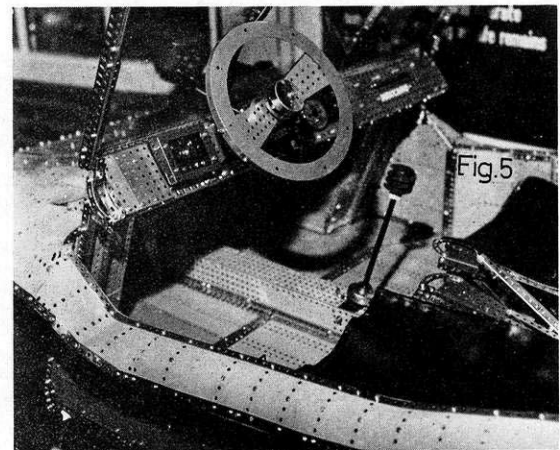

Below left: looking through the engine compartment to one of the rear wheels. Note the simulated shock absorbers and the use of Flanged Wheels for the engine exhaust pipe. Below right: the inside of the Buggy showing the dashboard, steering wheel, etc.

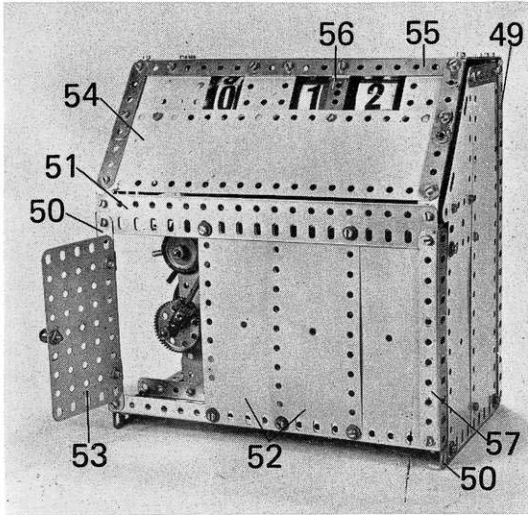

Look - No Hands!

DIGITAL CLOCK

Up - to - the - minute model by 'Spanner'

ONE OF the most impressive models we have featured in MMQ since its launch last year was Bert Love's Grandfather Clock, featured in the October 1973 issue. Built out of the entire contents of a No. 10 Set, the model was a working tribute, not only to the skill of its designer, but also to the tremendous capabilities of Meccano as a constructional medium.

It occurs to us, however, that, because a grandfather clock is a traditional instrument with its origins in clock-making history, the uninitiated observer might think that Meccano, itself, was good only for historic subjects. If this should happen, then the Digital Clock featured here will dispel all such incorrect illusions! Digital Clocks are very much a part of ultra-modern life - as a glance in any clock-seller's window will show - therefore this model again proves the 'forever-modern' nature of Meccano.

CONSTRUCTION

Leaving the outer casing until later, a framework for the main clock mechanism is built up from a $5\frac{1}{2}$ " x $2\frac{1}{2}$ " Flanged Plate, to each side flange of which two $5\frac{1}{2}$ " x $3\frac{1}{2}$ " Flat Plates 1 are bolted to form a $6\frac{1}{2}$ " x $5\frac{1}{2}$ " compound flat plate. Note that the Bolts fixing the "front" plate to the Flanged Plate also hold a $9\frac{1}{2}$ " Angle Girder 2 in place, while the "back" plate fixing Bolts help to hold two $2\frac{1}{2}$ " Angle Girders 3 in position. Bolted to each upper corner of each plate is a 3 " Angle Girder 4 projecting a distance of three holes horizontally beyond the plate. The outer ends of each pair

of Girders 4 are connected together by a $5\frac{1}{2}$ " Angle Girder, to the vertical flange of which a Corner Gusset 5 is tightly fixed in the position shown. Plates 1 are further connected by three $2\frac{1}{2}$ " x $\frac{1}{2}$ " Double Angle Strips, one bolted through the top row, centre holes of the plates and the other two through the second row down, second and fourth holes in from the right when looking at the front plate. Note that the inner of these latter two Double Angle Strips (numbered 6 in the illustration) will later serve as one of the bearings for one of the operating Rods. Two 3 " Strips 7, one on top of the other for increased strength, are bolted to front plate 1, in the position shown, to project four holes above the plate, while a 2 " Strip 8 is bolted in a corresponding position to back plate 1, this Strip projecting two holes above the plate. A Crank is fixed to the back of Strips 7, its boss coinciding with the upper holes in the Strips.

SYNCHRONOUS MOTOR

Dealing, now, with the motor which drives the clock, this is a synchronous unit built up from standard and electrical parts. Four Electrical Cylindrical Coils 9 are each fixed to a $1\frac{1}{2}$ " Angle Girder, the securing Bolts passing through the round holes in the Girder. A Core is carried in each Coil, being held in place by a Bolt screwed through the centre round hole in each Angle Girder and into the threaded centre of the Core. Using the slotted holes of the Girders, the Coils are then tightly fixed to back plate 1 in the positions shown, but note that each

Angle Girder is spaced from the plate by four Washers on the shank of each securing $\frac{1}{2}$ " Bolt.

Freely revolving between the electro-magnets formed by the Coils-with-Core, is an 8-pole armature 10, built up from two 8-hole Bush Wheels, to each of which eight Rod and Strip Connectors are bolted, the shanks of the Rod and Strip Connectors radiating outwards uniformly. The armature is mounted on a 4 " Rod journaled in the centre holes of plates 1 and carrying at its other end a $\frac{1}{2}$ " Pinion.

It is as well to wire up the motor at this stage and ensure that it operates correctly. Looking at the motor as it appears in the appropriate photograph, one power source terminal is connected to the "S" terminal of the lower Coil and the "E" terminal of the left-hand Coil. The other power source terminal is connected to the "E" terminal of the upper Coil and the "S" terminal of the right-hand Coil. The "E" terminal of the lower Coil is connected to the "S" terminal of the upper Coil, while the "S" terminal of the left-hand Coil is connected to the "E" terminal of the right-hand Coil.

The motor requires an input of 15 volts AC and, to set it operating, the armature should be spun anticlockwise at 750 r.p.m. This speed is "synchronous" with Alternating Current and, when it is reached, the armature should continue spinning unaided. Needless to say, the armature must be extremely free-running as, indeed, should be all the Rods and gear trains of the Clock. With this point in mind, it is advisable to take

special care in selecting the Rods and Gears, etc. for the remainder of the Clock, ensuring that all the Rods are perfectly straight and that the Gears run quite true.

CLOCK MECHANISMS

Dealing next with the clock drive mechanisms, it is as well to follow things through in their natural operating sequence. In mesh with the Pinion on the front end of the armature shaft is a 57-teeth Gear Wheel 11 on a 3½" Rod journalled in plates 1, vertically beneath the armature shaft. Fixed on the Rod, behind the front plate, is a ¾" Pinion 12 which meshes with a 50-teeth Gear Wheel 13 on a 3½" Rod journalled in the plates alongside the previous Rod. A Collar is mounted on the Rod, in front of the plate, followed by a ½" Pinion 14. This Pinion meshes with a 2½" Gear Wheel 15 on another 3½" Rod, above it, this Gear also being spaced from the plate by a Collar. A ½" Pinion 16 is carried on the same Rod, behind the plate, this also meshing with a 2½" Gear Wheel on a 3½" Rod journalled above the previous Rod. A ½" Pinion 17 on the front end of the Rod meshes with yet another 2½" Gear Wheel 18 on a further 3½" Rod, journalled alongside the previous Rod to the right, viewed from the front of the mechanism. A Collar behind the front plate holds the Rod in place.

A Threaded Pin 19 is tightly locked in one of the slotted holes in the face of Gear Wheel 18 and, as this Pin activates the "click-over" movement of the unit-minutes digit wheel, its position in the slot is critical. It lies approximately in the centre of the slot, but its exact final

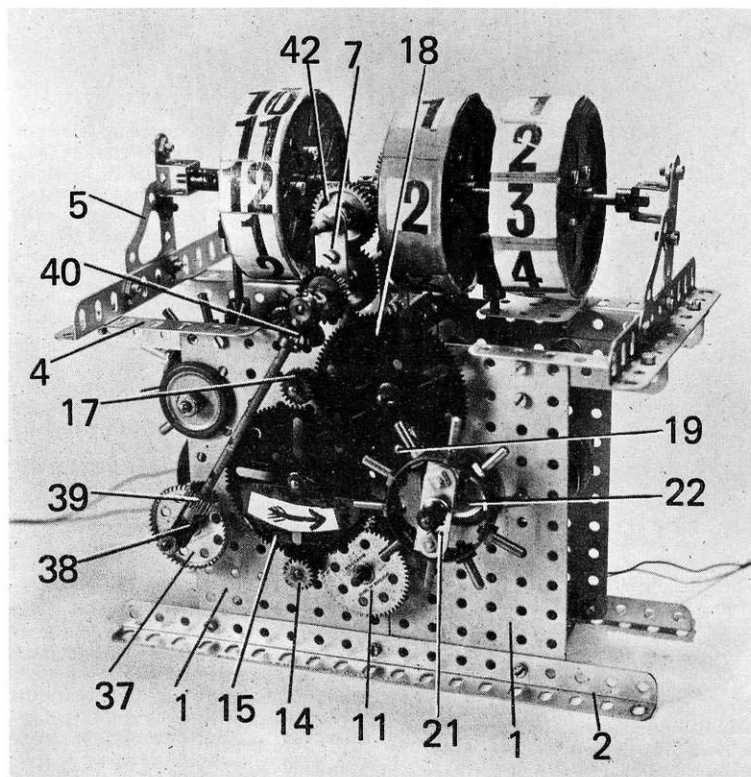

position should be determined under test when the completed mechanism is running.

"PRONG WHEEL"

The Threaded Pin makes contact with the arms of a "prong wheel"

which is built up from a 5½" Strip 20 which is very carefully shaped to form a ring, the ends of the Strip overlapping and being fixed together by a Threaded Pin which also fixes an Angle Bracket to the inside of the Strip. Another Angle Bracket, positioned diametrically opposite the first, is fixed to the Strip by another Threaded Pin, then the two Angle Brackets are connected by a Double Arm Crank 21. Eight further Threaded Pins are secured in the remaining holes in the Strip, then the complete unit is fixed on the outer end of a 4½" Rod journalled in plates 1. The Rod is free to slide a short distance in its bearing, but is prevented from excessive movement by a friction plate provided by a 1" Pulley 22, fitted with a Rubber Ring and mounted on the Rod in front of front plate 1. The Pulley is held against the plate by the action of a Compression Spring carried on the Rod behind the plate and held in place by a Collar.

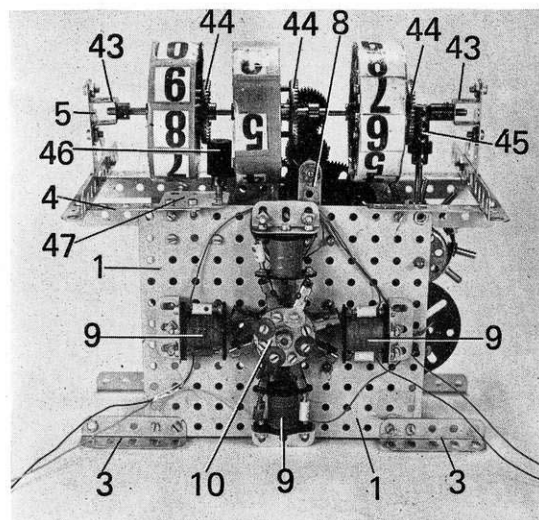

Opposite page: the finished 15 volt electric Digital Clock described in this article. Above: a front view of the Clock mechanism. To start the synchronous motor, Gear 15 is turned in the direction indicated by the arrow; a lot of very patient "flicking" may be necessary to reach the exact speed. Left: a rear view of the clock mechanism showing the built-up synchronous motor.

Also mounted on the Rod, between the plates, is an 8-hole Bush Wheel 23 and a 1½" Contrate Wheel 24. Fixed by two Nuts in one of the holes in the face of the Bush Wheel is a 1-1/8" Bolt, its head

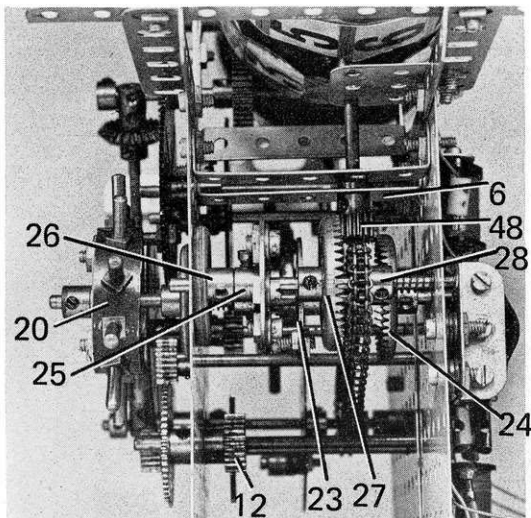

A close-up view of the Digital Clock mechanism, looking into the right-hand end of the unit. Prong wheel 20 controls the 'click-over' movement of the unit-minutes digit wheel, while Sprocket Wheel 28 extends drive, via Sprocket Chain, to the ten-minute digit train at the other end of the unit.

projecting approximately $\frac{1}{4}$ " outwards. As the Bush Wheel revolves, this bolthead makes intermittent contact with the heads of six ordinary Bolts fixed in the holes in the face of a 6-hole Bush Wheel 25, mounted on a 3" Rod journalled alongside the previous Rod. Also mounted on this last Rod, in addition to Bush Wheel 25, are a 1" Pulley with Rubber Ring 26, a $\frac{1}{2}$ " Contrate Wheel 27, a $\frac{3}{4}$ " Sprocket Wheel 28 and a Compression Spring. Pulley 26 with the Rubber Ring again serves as a friction plate, being held against the back of front plate 1 by the action of the Compression Spring.

Sprocket Wheel 28 is now connected by Chain to another $\frac{3}{4}$ " Sprocket Wheel 29 fixed on a $\frac{1}{2}$ " Rod 30 held by Collars in plates 1 at the other end of the mechanism. Mounted on the Rod, between the plates, is a Face Plate 31, in one of the slotted holes in the face of which a $\frac{3}{4}$ " Bolt is fixed by lock-nuts. Revolving, free, on the protruding shank of this Bolt are three Washers and a Collar 32, this unit serving as the "Click-over" activator for the digital hour wheel. As with the previous unit-minutes wheel, this activator engages with the arms, or teeth, of a "prong wheel" 33, this one built up from two $\frac{3}{2}$ " Strips curved to shape and fixed together to form a ring of $6\frac{1}{2}$ " (thirteen holes) circumference. As before, Threaded Pins are tightly fixed in all the holes of the ring to radiate outwards and a Double Arm Crank is fixed across the diameter of the ring by two Angle Brackets, secured in diametrically opposite positions. Note that the Double Arm Crank is bolted to the

elongated hole lugs of the Angle Brackets.

The prong wheel is fixed on a $3\frac{1}{2}$ " Rod journalled in the end row, third holes down of plates 1. Also mounted on the Rod, between the plates, are a fixed $\frac{1}{2}$ " Contrate Wheel 34, a loose Coupling 35 (the Rod passing through its lower transverse bore), a Collar and a Compression Spring, with a 1" Pulley with Rubber Ring 36 being fixed on the front end of the Rod. Again, the Pulley with Rubber Ring acts as a friction plate being held in contact with the front Flat Plate by the action of the Compression Spring.

Coupling 35 acts as the lower bearing for a vertical Rod, but, before dealing with this, it is better to complete the initial drive to the ten-minute digit wheel. Mounted on Rod 30 in front of front plate 1 is a fixed $\frac{1}{2}$ " Contrate Wheel 37 and a loose Short Coupling 38 held on the Rod by a Collar. The Rod passes through one transverse bore of the Coupling. Journalled, free, in the longitudinal bore of the Coupling is a $4\frac{1}{2}$ " Rod, carrying a $\frac{1}{2}$ " Pinion 39 (meshing with Contrate 38) and a $\frac{7}{8}$ " Bevel Gear 40. The upper end of the Rod is also journalled in the longitudinal bore of a Short Coupling, this one held by a Collar on a $4\frac{1}{2}$ " Rod mounted in the third holes down of Strips 7 and the upper end hole of Strip 8. Fixed on the Rod in front of Strips 7 is a $\frac{7}{8}$ " Bevel Gear, which meshes with Bevel 40, while a 1" Gear Wheel 41 is fixed on the Rod behind the Strips.

In mesh with Gear Wheel 41 is a second 1" Gear 42 on a 2" Rod

journalled in the boss of the Crank bolted to the back of Strips 7, where it is held in place by the Gear Wheel and a Collar. A $\frac{1}{2}$ " Pinion, boss inwards, is fixed on the inner end of the Rod.

DIGIT WHEEL

Now bolted to the vertical arms of Corner Gussets 5 are two Double Bent Strips 43, which serve as bearings for an 8" Rod on which the three digit wheels are mounted, free. Each wheel is similarly built up from two 3" Pulleys, boss to boss, fixed together by $1\frac{1}{8}$ " Bolts, on the outer ends of the shanks of which a $1\frac{1}{2}$ " Contrate Wheel 44 is fixed. The wheels, being free to turn on the Rod, are held in position by Collars at each side. Strips of cardboard are wrapped around the wheels and fixed in place with sticky tape. Stuck to the card are the necessary clock numerals which must be evenly spaced around the wheels. We used $\frac{3}{4}$ " numerals cut from some number-sheets we had available, but the numerals included in the Letraset or similar rub-on ranges would be ideal.

Also located, free, on the supporting Rod is a Coupling 45, the Rod passing through the end transverse bore of the Coupling. Revolving in the longitudinal bore of this Coupling and in the longitudinal bore of Coupling 35 is a 2" Rod on which two $\frac{1}{2}$ " Pinions are fixed. The lower Pinion engages with Contrate Wheel 34, while the upper Pinion engages with the Contrate Wheel incorporated in the hour-digit wheel. The Contrate incorporated in the ten-minute digit wheel meshes with the $\frac{1}{2}$ " Pinion on the same Rod as Gear Wheel 42, while the Contrate incorporated in the unit-minute digit wheel meshes with a $\frac{1}{2}$ " x $\frac{3}{4}$ " Pinion 46 on the upper end of a $2\frac{1}{2}$ " Rod journalled in Double Angle Strip 6 and in the corner hole of a $1\frac{1}{2}$ " x $1\frac{1}{2}$ " Flat Plate 47 bolted to nearby Angle Girder 4. A $\frac{1}{2}$ " Pinion 48 on the lower end of the Rod meshes with Contrate Wheel 24 and note that the Rod is prevented from sliding in its bearing by this Pinion and a Collar above the Double Angle Strip.

This completes the Clock mechanism and, before proceeding any further, it is advisable to test it thoroughly. Pay particular attention to the three friction plates provided by 1" Pulleys with Rubber Rings, making quite sure that they do not make too strong a contact with the Flat Plates. The friction plates are of

course provided to hold the digit wheels steady when stationary and the tension used should be no greater than the minimum required to ensure this.

CASE

Turning now to the case, this can of course be built to your own design to conform to your own artistic tastes. In our model, however, the back is supplied by a simple square framework, built up from four 9½" Angle Girders 49, enclosed by four 9½" x 2½" Strip Plates, suitably overlapped. For the vertical front panel, a smaller rectangle is built up from two vertical 5½" Angle Girders 50, connected at top and bottom by two 9½" Angle Girders, the upper securing Bolts also holding a 9½" Flat Girder 51 in position. Three 5½" x 2½" Flexible Plates 52 are bolted between the 9½" Girders, the remaining space being enclosed by a door provided by a 4½" x 2½" Flat Plate 53 attached to one Girder 50 by two Hinges. A Handrail Support serves as the door knob.

The upper corners of Flat Girders 51 are extended by Obtuse Angle Brackets, to which is bolted a 9½" x 2½" Strip Plate 54, each end of which is overlaid by a 4" compound strip, built up from two 2½" Strips. The upper ends of these compound strips are connected by a 9½" Strip 55, the securing bolts also holding Obtuse Angle Brackets in place. Bolted between Strip 55 and Plate 54 are four 2½" x 1½" Flexible Plates and a 2" Strip 56, all arranged to leave appropriate "windows" for the clock numerals. Bolted to the Obtuse Angle Brackets and to upper Girder 49 is the case top, provided by a 9½" x 2½" Strip Plate with its ends overlaid by 3" Strips. The base is not enclosed, but the lower corners at front and back are connected together by a 5½" Angle Girder 57 in each case. Each side is built up from a 9½" x 2½" Strip Plate, a 5½" x 2½" and a 2½" x 1½" Flexible Plate and a 3½" x 2½" Triangular Flexible Plate, all bolted together and edged along the top by a 3" Strip. The lower end of the assembly is bolted to Angle Girder 57.

Needless to say, the clock unit must be fixed in place before the case is completed! Mounting is perfectly straight-forward: Angle Girders 3 and 4 are bolted to Girders 57, while the front end of the 5½" Angle Girder carrying Corner Gusset 5 is bolted to the 9½" Angle Girder behind Flat Girder 51 in the case front. With the Clock fixed in the completed case, of course, the arm-

Another close-up view of the clock mechanism, this time looking into the left-hand end of the unit. Prong Wheel 33 controls the 'click-over' movement of the hour digit wheel. Care should be taken when selecting all gears for the Clock to ensure that they are in no way bent or distorted.

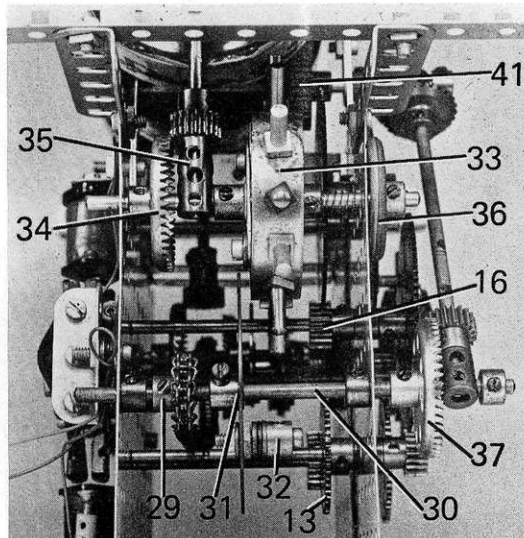

ature is inaccessible for spinning to start the synchronous motor. However, the same effect is achieved by turning Gear Wheel 15 in the direction indicated by the arrow and door 53 is, in fact, provided to allow easy access to the Gear.

Taken as a whole, the Meccano Digital Clock is an interesting and very useful model. It may not be as large, or as visually impressive as Bert Love's Grandfather Clock, but it does do the same job - keep the time - and it does it remarkably well. A good example of advanced Meccano modelling!

PARTS REQUIRED

1- 1a	7-16	2-31	1-103a
1- 2	2-16a	170-37a	2-108
2- 3	1-17	152-37b	9-111
4- 4	6-19b	60-38	12-111d
4- 5	3-22	2-45	2-114
3- 6	3-24	3-48a	23-115
8- 8a	1-24b	1-52	2-120b
6- 9	1-25	4-52a	3-155
4- 9c	5-26	17-59	6-188
2- 9d	1-26b	2-62b	5-192
4- 9h	1-27	1-63	8-196
4-12	1-27a	2-63d	16-212
4-12c	3-27c	1-74	2-226
1-13a	6-28	1-94	4-522
1-15a	2-30	2-96a	4-528
2-15b			10-612

THIRD ANNUAL MECCANO EXHIBITION

HENLEY-ON-THAMES Open Friday & Saturday,
TOWN HALL. 10 a.m. - 6 p.m. 30th & 31st August.

Friday will be a special MECCANO enthusiast's day when readers of the MMQ, club members, model builders generally, and their families are invited to meet each other and display their work. On Saturday the Exhibition will also open to the general public.

Admission: Adults: Friday 25p. Saturday 10p.
Exhibitors Free Children: Friday 10p. Saturday 5p.

MW Models 165, Reading Road, Henley-on-Thames, Oxon, RG9 1DP., England.



Above and below, No. 2253 Ford Capri Police Car – second in the new range of big 1/25th scale models. Finished in the livery of 'Lancashire Constabulary', the model is packed with fine detail and sports a wealth of action features ranging from opening doors, bonnet and boot, through fully-fitted-out interior, engine, underbody and exhaust details, right down to scale reproductions of the original's 'mag' wheels. Overall finish is in white with orange stripes down either side and a "LANCASHIRE CONSTABULARY" decal on each door. A roof-console sports a simulated blue flashing-light, siren representations and "POLICE" labels, whilst a console on the boot lid forms an "ACCIDENT" label.



Below, No. 291 City Bus is based on the existing "Yellow Pages" Atlantean Bus casting with a new livery. Features include glazed windows, seats, a driver representation and Speedwheels. Produced to 1/76th scale, it has an overall length of 123.5 mm and is finished in orange with a white engine cover and interior. It sports "KENNING CAR, VAN AND TRUCK HIRE" labels on the sides, a "KENNING MOTOR GROUP" label at the rear and a route number/destination label at the front. Although not illustrated, the Atlantean Bus has been released in unpainted form under Sales No. 1018 Atlantean Bus Kit. The Kit comprises thirteen components, including Speedwheels, and the metal parts are pre-treated ready for painting. The Kit includes a phial of white enamel and a sheet of waterslide transfers of the red and blue "NATIONAL" bus company name and insignia.



DINKY TOYS NEWS

A look at the new Dinky Toy models released since the last issue of "Meccano Magazine Quarterly".



Above, No. 692 Leopard Tank produced to 1/50th scale. Action features include working crawler tracks, a simulated engine noise which is emitted when the model is pushed along, a revolving gun turret and an elevating, breach-loading, spring-operated gun which fires small plastic "shells". Other features include twin whip-type aerials and a machine gun representation. Overall finish is in matt olive drab, with black ancillaries and grey tracks.

MECCANO SETS & PACK PARTS 1-235f POST FREE

(UK ONLY)

MECCANO orders for Sets or packs of standard parts are simple to deal with, so we are happy to pass on the benefit of this saving to you by sending all such orders POST-FREE anywhere in the UK.

Other items or odd quantities can of course be sent at the same time, but you will understand that we will have to reserve the right to charge postage on the whole order in such cases.

Special Form available showing all pack quantities (mainly sixes & threes).

M.W. MODELS

165, Reading Road, Henley-on-Thames, Oxon, RG9 1DP. Tel (04912) 3342.
Open Monday to Saturday, early closing Wednesday.

MOON-DRIVE MECH.

as fitted to Bert Love's No.10 Set Grandfather Clock (Oct. '73 MMQ)

SINCE THE GRANDFATHER Clock was first featured in M.M.Q. No. 3 (writes Mr. Love) some slight alterations to the moon mechanism have been incorporated to give yet another dial to the Clock, although still keeping within the No. 10 Set limitations. In following this description, readers are advised to consult the original article in issue No. 3 as several references to previous illustrations are important.

Referring to Fig. 4 on page 63 of MMQ No. 3, showing the main clock dial, the lower small dial is the 24 hour dial (not the seconds hand dial as was mistakenly indicated in the original article) and it is from this 24 hour dial, which turns on what is known as the "diurnal" shaft, that we take off the moon drive in stages. A 2½" Rod forms the diurnal shaft which runs through to the front clock plate behind the dial and is located so that it does not foul the external gears of the main winding drum revolving behind the clock plate. This diurnal shaft carries a 1½" Sprocket Wheel (which receives a 2:1 step-down motion from an hour shaft via a ¾" Sprocket Wheel) and behind the 1½" Sprocket, a Worm takes up most of the remaining portion of the 2½" Rod.

Now referring to Figs. 5 & 6 on page 64 of MMQ No. 3 we can see

the ¾" Sprocket Wheel just mentioned, plus two more Sprocket Wheels which carry the moon drive in its second stage up to the top of the clock. The lower Sprocket Wheel is 1" diameter and has 18 teeth. It is fixed to a 4½" Rod carried in Trunnions at either end of the lower front clock plate. Towards the inner end of this Rod, a ½" Pinion is secured to engage with the Worm on the diurnal shaft. This means that, in 19 days, the 1" Sprocket will revolve once.

As the upper Sprocket Wheel is ¾" diameter and has 14 teeth, it speeds up the motion of the lower Sprocket and is fixed to another 4½" Rod carried in a 2½" x 1½" Double Angle Strip attached to a 3" x 1½" Flat Plate as shown in Fig 1 on this page. Both ends of this Plate are attached to the inside ledge of the ornamental clock top by Trunnions, the middle Trunnion carrying a 5½" Strip running to the top rear of the clock and holding a 5½" x 2½" blue Plastic Plate which forms an excellent curved background 'sky' for the moon globe.

To accommodate the new dial shown in Fig. 2 here, a slight change in gear positioning is required, the two Bevel Gears going inside, while the large Contrate and 50t Gear are mounted outboard as shown in

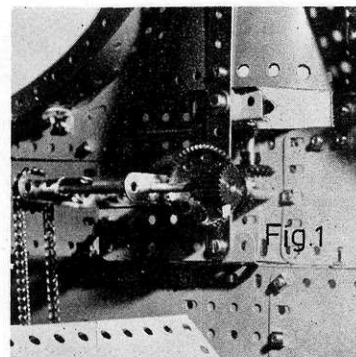

Fig. 1. It is necessary to have the 50t Gear running on the far side of the Contrate as shown to give correct rotational direction to the 'Age of Moon' indicator. The dial requires 29½ divisions.

Fig. 2 should make all of the final stage moon drive clear. Two sections of the Age of Moon shaft are provided, linked with a Rod Connector as shown to give a 'slip' drive to the indicator hand for resetting the Age of Moon without back-winding the whole clock mechanism. So far, the gear train gives us the following ratio:

$$\frac{\text{Worm}}{19t} \times \frac{18t}{14t} \times \frac{25t}{50t} = 29.555$$

Thus the moon globe will rotate once in 29.555 days which is more accurate than most domestic grandfather clocks with simple moon motion. Credit for the moon train gear used goes to Pat Briggs - well known in Meccano clock-building circles.

Perhaps a word on making the moon globe will be welcome. A standard table tennis ball is used, but this should be pierced with care, using a darning needle to probe for a central axis. If the ball spins eccentrically, correct with a fresh hole at the tip of the needle until rotation is reasonably concentric. Open up the holes with a fine rat-tail file until they are a free-running fit on a Meccano Axle Rod. The Compression Spring shown in Fig. 2 gives a positive grip on the ball, but allows re-setting as required. Indian ink, brushed on with a small sable brush, should be used for shading one half of the table tennis ball. When faced squarely, the ball will present the correct moon phase to the observer. N.B. If any of our friends in the antipodes build this clock they will need to reverse the lower level of Fig. 2 for correct moon phase!

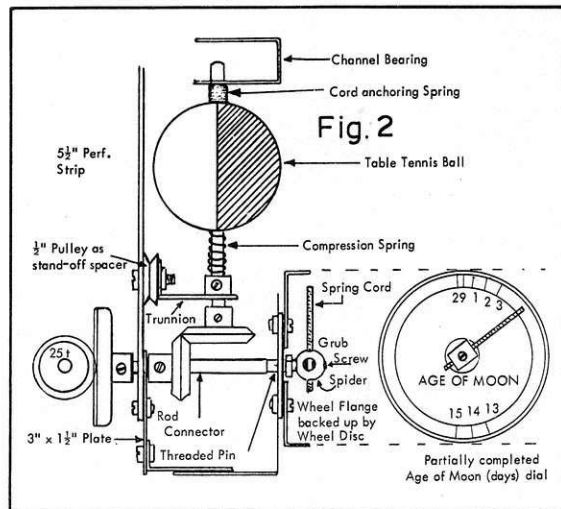

Alterations to moon-drive in No. 10 Set Grandfather Clock to add 'Age of Moon' dial with existing parts in Set. With Age of Moon pointer rotating clockwise, moon phase appearance of half-black table tennis ball is correct for observer in Northern Hemisphere. For Southern Hemisphere observers, lower Bevel Gear would have to be changed over from left to right to reverse moon globe direction.



A PRIZE TO BE TREASURED

This picture shows the Stuart H. Wilson Cup which has been donated to the Holy Trinity Meccano Club by its President, Mr. Stuart H. Wilson. The Cup serves as a model-building trophy which is presented half-yearly to the H.T.M.C. member who, in the opinion of fellow members, has produced the most meritorious model in any qualifying six-month period. First, and current holder (at the time of writing) of the trophy is Club Sec. Tony Homden, but a new winner for the second term will be chosen by vote at the next Club meeting to be held on 27th April. Judging by the high standard of models appearing at meetings, the choice will be a difficult one! (We have no written report from the H.T.M.C. this issue).

ACORN MECCANO CLUB

The acorn has not yet begun its growth to Oak Tree proportions, but interest and enthusiasm within the Club increases continuously! Most of the lads received some Meccano as Christmas presents in 1973, and there is a strong urge to save-up for electric motors to add more fun to their activities. It is encouraging to see that they all bring models along to meetings, although the meetings are primarily intended as building sessions using the Club's stock of parts.

The display at the local school has been postponed until July 1974, when it will be a side attraction at the annual sports day. We hope to have a fair range of models to put on show by then. A short lecture with demonstrations on mechanisms is planned for the near future — it is hoped that this will broaden the lads' horizons a little, and render them "brassware-conscious".

Bernard Dunkley.

CAPE TOWN MECCANO CLUB

Since the last Cape Town M.C. report appeared in MMQ, the Club has held a number of regular meetings and also an exhibition at the Booth Memorial Home, the latter last November in conjunction with a Fete for Salvation Army funds. We were able to mount an impressive array of models — some 31 in all — ranging from the very small, through the intermediate, to the large and complex. Unfortunately, lack of space prevents descriptions being given, but suffice it to say they were all worthy of mention. Public attendance at the Exhibition, however, was disappointing and raised doubts as to the point in putting on a show unless it was fairly certain that a large number of people would attend. The Hon. Sec., Colin Cohen, had better results, however, when he mounted a display of 13 models at the Post Office Hobbies Exhibition. This was well-attended, despite sparse advertising by the organisers.

The last official gathering of the Club at the time of

MECCANO CLUB ROUNDUP

All Meccano Clubs are invited to submit reports for these pages. Reports should be approximately 350 words long, and should reach us by the end of the second month before month of publication.

writing was the 26th Meeting, held on 19th January. The venue was the recently-established Club Headquarters, a room 18' x 13' attached to the Secretary's home. The walls are painted yellow and two trestle tables, on which models are displayed, are finished in french grey. A bookcase is filled with Meccano literature, while photographic memoirs of past events and models in both the Cape Town M.C. and the Old Cape Peninsula M.C. adorn the walls.

It was reported at the meeting that the Secretary had written to the Lady Buxton Home on behalf of the Club, offering to mount a Meccano display at the forthcoming Lady Buxton Home Fete. The Home had replied, expressing interest in the offer and requesting details of Club requirements. These were discussed and the Sec. undertook to take the matter further. (*The Fete was due to take place on March 2. We have not heard the outcome at the time of writing — Ed.*)

Among other things discussed were some specially-designed signs which had been produced to guide visitors to Club displays. It was also decided that some large signs were required, possibly made out of polystyrene, and it was agreed that this would be looked into. The Sec. also reported on the surprise visit on Christmas Eve of a Meccanoman from England — Ian Newton of the Holy Trinity M.C. Ian and his brother had been visiting the Country and, being in the area, they dropped in for a chat. Despite having over-celebrated at a party that morning, the Sec. was able to uphold the tradition of international Meccano friendship!

After displays of members' models, brought along for the occasion, the meeting finally broke up with the last word going in thanks to Marion Cohen for her much-appreciated refreshments.

CHRISTCHURCH MECCANO CLUB

The British Commonwealth Games did not stop Christchurch Meccano Club members from continuing to build a fine selection of Meccano models in preparation for their biggest and best-ever Meccano display. Variety was the keynote, with well over 30 models on display. Some which stood-out from the rest were a beautifully-detailed model of a Block-Setting Crane, a 7ft. tall Eiffel Tower, a stationary Steam Engine and a Chess Set. However, all models were of a very high standard and all added to an overall impressive effect. The Club was very fortunate in being loaned six 'working' models from Meccano Limited, and these added their own special attraction to the display. We were also very lucky in having articles about the display appear in two local newspapers and having a mention in the local news on television — all of which helped to advertise both the display and our Club which, incidentally, has gained about 12 new members.

The display was held from the 11th-22nd February in the Christchurch Building Centre (a display centre for building materials and techniques). This gave us an extra week as it was originally meant to run for only one week. At times, people stood five-deep gazing at the models, and many stayed and watched for up to quarter-of-an-hour at a time.

Overall, the Club was very pleased with the success of our display, but members have no time to "rest on their laurels" as they are busy building new models for another display to be held during the May school holidays in a large departmental store in Christchurch City.

Kingsley Burrell.

HENLEY SOCIETY OF MECCANO ENGINEERS

One of the many agreeable features of the modern Meccano societies is the freedom members feel to visit clubs other than their own. We certainly enjoyed our visit to the Holy Trinity M.C. last year.

We try to make our meetings as open-house as possible; all you have to do is be enthusiastic about Meccano — and pay your meeting sub. We have found that what most people seem to enjoy is the opportunity to meet and talk Meccano, whether they bring a model or not. The topics of conversation are extraordinarily varied

and listening to one group after another resembles leafing through an old Meccano Magazine!

Around 40 of us were present on February 2nd and once again, it was our pleasure to welcome distinguished members from the fraternity far afield, with their models. We were also very pleased to see so many of the juniors who stayed on from their afternoon meeting with Mike Nicholls. Dennis Thomas was the Chairman on this occasion and he set a literally shining example with his enormous Japanese Gantry Crane, all built from gleaming new parts. Peter Wilson showed a large fairground Dive Bomber with full automatic programmed control. He also brought a caterpillar chassis with track built-up from standard and Multikit parts. Amongst many splendid models we noted Esmond Roden's large Block-setting Crane and a re-build of a well-known Tank Loco from the vintage years. There was a similar model of the Midland "Spinner" from Paul Jack. Bob Ford brought an impressive 8-wheeled Lorry Chassis and Tony Homden came from Kent with the old H.M.S. Dreadnought. Battleships always make magnificent models, but this one is going to be outstanding. The screws work from a Meccano Steam Engine which exhausts up the smoke stacks; there is a remote-control of the turrets and even a remote stoking device for the meths. A lorry from pre-war No. 8 Manual was shown by Tony Knowles.

The centre spot of the evening was a film, shown by Mike Nicholls, about Liverpool and including shots of the Meccano factory. We also had a slightly chaotic race of Clockwork Tractors: the result was apparently inconclusive.

Alf Reeve.

Enquiries please to Geoff Wright, 165 Reading Road, Henley-on-Thames, Oxon.

HENLEY SOCIETY OF JUNIOR MECCANO ENGINEERS

The December meeting was well attended despite foul weather, petrol shortages and a ban on the electrical heating of our hall!

The usual wide range of members' models were on show at the meeting, including a 5'4" Contractor's Crane by Paul Smith. Christopher Reeve showed his beautifully-proportioned 57 Pannier Locomotive which was powered by an obsolete Embo Motor. Our "novelty" modeller, Peter Roberts, brought along a model of the famous Trojan Horse, complete with model soldiers inside! As if this was not enough, Peter also showed us a model of the "Loch Ness Monster".

A picture in a library book gave the inspiration for a Tram built by Neil Packer, whilst the Meccano Magazine Quarterly was the point of origin for Ian Henwood's Grandfather Clock. Ian's model is based on the superb construction by Bert Love seen in MMQ No.3. Ian had completed the frame of the clock at the time of the meeting, and we look forward to seeing the model at a later stage.

An in-depth discussion on clock-building was the main "organised" part of the meeting, and the text of the talk was later published in the "Junior Meccano Engineer" No. 2.

Although the January meeting was attended by only 27 members, some extremely interesting models were brought along. Dominating the display was an enormous Level-luffing Crane by Stuart Matthews. Two other types of crane were represented: a Contractor's Crane by Peter Simpson and a Lorry-mounted Crane by Nigel Robb. Nigel Colverson had a beautiful model of a GWR Parcels Van, and Timothy Ball had a steam-operated Roundabout. A model of the Moscow TV Tower was brought by Paul Smith, but the model was so tall and slender that it spent the meeting in a horizontal position! The main talk at this meeting was about gearing, and was given by Steve Sawarjyn.

The February meeting was centred around a discussion about electricity and magnetism and their uses in Meccano modelling. Both this talk and the one on gearing will appear in the "Junior Meccano Engineer" No. 3.

Two other interesting points at the February meeting

were the appearance of Ian Henwood's completed Grandfather Clock and a production sample of the new Super Highway Multikit, kindly loaned to us by M.W. Models. This was the first public viewing of this new outfit, occurring only a few days after the first trade showing at the Brighton Toy Fair. The outfit was obtained by the very kind co-operation of Meccano Limited.

The HSJME continues to flourish and the "Junior Meccano Engineer" magazine, which was originated in the society, is proving very popular with members and non-members of all ages.

Mike Nicholls.

NORTH WESTERN MECCANO GUILD

Saturday 5th January was the date fixed for the first full meeting of the newly-formed North Western Meccano Guild. The Chairman, Sidney Whiteside, kindly provided space at his home in Clitheroe, but although the room was quite large, it soon became evident that it wasn't large enough - especially when Martyn Brown from Leyland proceeded to assemble his huge Level-Luffing Crane. It was so big that he had to rack the job down to prevent it hitting the ceiling! Among the model's features were remote-controlled luffing, slewing, hoisting and travelling from a hand-held control box. His brother, Graham, (13) showed a superb model of a Tractor Shovel. Powered by a mains motor, and working through a frighteningly-complex gearbox, Graham's model copied every function of the original, even down to a sliding seat in the cab!

Bill Barker exhibited a model Tank with functional tracks driven through a differential, and a "working" gun. He also demonstrated a model of an American long-range Howitzer, again mounted on caterpillar tracks. John Nuttall's high standard of modelling was displayed in a unique design of Meccanograph, totally different from any seen before. Also in evidence was his impressive Lorry-mounted Crane. Sidney Whiteside, who is a devoted fairground enthusiast, showed a model of a Waltzer and explained the unusual method of driving the model. The chairs fitted to the revolving platform swing round in a haphazard fashion when the model is working. The Secretary showed a model of a fastback high-powered American Car.

All present voted the meeting a tremendous success for our first attempt, and we look forward to our next meeting which is in July.

Michael J. Walker.

SOCIETY OF ADVANCED MECCANO CONSTRUCTORS

The inaugural meeting of the S.A.M.C. was held in Hall Green, Birmingham, on Saturday 16th March 1974. Cars loaded with models arrived from all over the country and the tables in the Baptist Church Hall were soon filled with advanced models of all descriptions.

At about 2.10 p.m. Leslie Dougal, this year's Chairman, opened the meeting with apologies from James Grundy, Tom Masters, John Palmer, Bert Shaw and Peter Dixon, and fraternal greetings from overseas members. Leslie then introduced Hubert Lansley, "Spanner" of the 1923-1930 Meccano Magazines, as the newly-appointed President of the S.A.M.C. Hubert gave a short address expressing his thanks and delight at being appointed President and promised to continue providing articles for the Society's magazine, the DRIFT, on the early days at Liverpool. He then declared the meeting open, and left Bert Love to give out notices. That concluded all the formalities of the meeting and the tour of models began.

David Whitmore showed an array of models, including an early French Reciprocating Steam Engine, a Feathering Paddle Wheel, a Miniature Sports Car and two Ellipse Drawing Trammels. Roger Wallis, this year's Vice Chairman, showed an L.C.C. Double Decker Tramcar, a "Karrier" type Trolley Bus and a Leyland "Atlantean" Omnibus between them covering the period 1924-1974 in transport. A Table Clock with second-hand and moon motion working throughout by "economy" gearing was shown by Pat Briggs; he also showed a sample of the No. 10 Grandfather Clock built entirely unaided by his 15 year old son, John, from the instructions published in last October's MMQ.

Leslie Dougal had several models on display including a working Rack Railway, a module-constructed Synchronous Motor, "Dufour's Geometrical Apparatus" (1918 Model) and a novel Pedometer, operated by body motion in walking and small enough to fit inside a pocket! Eric Jenkins had a Mobile Coles Crane, Paul Blythe a full automatic version of the S.M.L. Grabbing Crane, while Michael Martin gave a showing of his reduced-scale steam-operated Block-setting crane.

Jim Gamble provided the novelty of the meeting with an "O" Gauge Tramcar Circuit, the Meccano Tram running with authentic pick-up from overhead, but being programmed with stop/start mechanism which rang the appropriate bells inside the tram car for correct conductor/driver signals! Clive Hine's outstanding fairground models included a Satellite illuminated with more than 100 coloured lamps - and a lorry-mounted travelling Electric Fairground Organ with lights, organ pipes, band

master, etc., fully detailed and fed with piped music to an internal speaker.

The President produced a very interesting Coupling Mechanism for driving crankshafts, while Bert Love showed yet another Grandfather Clock - electrically driven with provision for day and date drives. Ralph Clark had a finely-detailed Wood Burner alongside a giant American Goods Loco built to the same scale, but more than twice the size.

Space precludes full justice to all the other models provided by Barry and Leslie Clay, Bill Winter, Paul Brecknell, David Guillaume and Roger Lloyd.

Refreshments were provided by member's wives and the meeting concluded with a presidential visit to thank them all.

Bert Love

(Details of the Society's meetings, activities and membership conditions may be obtained from the Hon. Sec. - 61 Southam Road, Hall Green, Birmingham 28. Please enclose a s.a.e. with any enquiries).

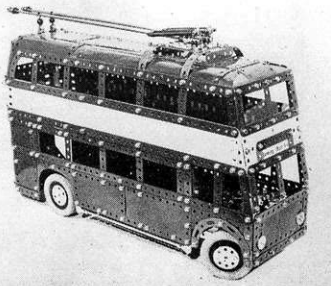

Roger Wallis's "Karrier" type Trolley Bus displayed at the inaugural meeting of the S.A.M.C. Pick-up via twin overhead insulated trolley poles. Full scale steering lock is provided.

STEVENAGE MECCANO CLUB

The Club membership continues to grow, 20 new members having been admitted during 1973. Recent newcomers include: John Kyle (12), Andrew Shields (10) and Michael Aldridge (7). A welcome also to new adult members, Robert Faulkner of Abingdon, Berks, and Peter Randall of Bromham, Beds., well known for his Hornby Train activities.

The programme of model-displays is already well-booked for 1974, so it is just as well that S.M.C. members received plenty of Meccano for Christmas!

As regards news of members, congratulations to Peter Walton and his wife Janet who married in 1972; they now have a baby son, Christopher - a future S.M.C. member we hope!

Traction Engine and Fairground Organ model by Jack Farrington were displayed at Xmas bazaars in Cross Keys, Monmouth, to raise funds for an old people's charity. A simple yet most realistic Pocket Meccano model of Concord, designed and built by Roger Le Rolland is featured in the British Aircraft Corporation factory magazine, "Airframe".

On January 4th a chartered coach took 34 members and 11 guests to the "Model Engineer Exhibition" at the Seymour Hall, London. The display of models, although interesting, contained little that was new; and the rationing of electricity meant that both heating and lighting were severely restricted. Nevertheless, an enjoyable day was had by one-and-all, enlivened by an unexpected close-up view of the Meccano "advertising" bus on London Transport route 159, as the S.M.C. coach drove along Baker Street.

Additional adult members are always welcome, and should contact the Secretary, Dennis Higginson, at 7 Buckthorn Avenue, Stevenage, Herts., or phone: Stevenage 53392.

John Foord

TRANSVAAL MECCANO GUILD

The tenth meeting of the Transvaal Meccano Guild took place on 9th February, 1974. The members eagerness to enjoy yet another meeting was certainly shown by the fact three members were already waiting outside the hall when the Hon. Sec. arrived and this has never happened before. Further evidence to this effect was that once again we had a record attendance of 24 members. As we have 33 members, 4 of whom live great distances away, we only had 5 members who couldn't make it.

An article on the Meccano Museum which appeared in

the Star newspaper was shown to members who were also told that the Star are interested in a further article on the Transvaal Meccano Guild at some future date.

Due to Pierre Marais's hard work and influence with the Pretoria librarian, the librarian has purchased a quantity of both of the books by B.N. Love for the lending libraries. When it is known that these books are in circulation I hope to persuade the Johannesburg librarian to do the same.

One of the first major subjects discussed was the forthcoming Rand Hobby Show, which will run from the 21st-28th September inclusive. An appeal was made for much more support from members than was given last year. Those members who assisted last year know that their fine help and enthusiasm was greatly appreciated. Remember this is *our* show!

After discussing various other subjects, we had tea and sandwiches which were prepared, as usual, by Anne and Frances Matthews. I then made a tour of the models.

There was a large selection of models displayed, including a Meccano 'O' Gauge Loco and Coach, built by Pierre Marais, the Servetti Magician and an extremely nice radio-controlled D.C.3. (Dakota) with a 5 ft. wingspan. Both models were built by Charlie Roth. Charlie had 3-speed control on each motor and working rudder, ailerons and elevator, all operated by radio-control.

My sincere apologies for not mentioning all the other wonderful models that you brought along to the meeting, but space does not permit.

Paul Hatty showed members a very nice moulded tray with many 2 1/2" x 3/4" compartments, the whole tray being at a guess about 2' x 1 1/2". Each side of the tray is extended outwards by about 1/2" and this could easily be used to slide a suitable groove cut into the side of the cabinet.

Next to show members yet another answer to the storage problem was Frank McClement. Frank showed us a metal storage cabinet from the KROST Evermanns Tool-box Range - these are very strong, very smooth-running drawers and there is a complete range of cabinets ranging from 3-drawer to 10-drawer free-standing, and two other large cabinets with deep drawers and mounted on 4" castors.

As our membership steadily increases so, of course, does our attendance at each meeting. It seems to me that the size of the models increases also, with the result that the hall and supply of tables is no longer adequate to meet our needs! In view of this, I have approached the Salvation Army for the use of their hall and have received a favourable reply. Our next meeting will be held at this hall on 20th April, and members will receive a map showing the location of the hall at a later date.

Peter Matthews.

PROPOSED NEW MECCANO CLUBS

Meccano enthusiasts in Yorkshire and Eire will be pleased to hear that a fellow enthusiast in each of these areas wishes to form a Meccano Club if response is favourable. The gentlemen to contact, if interested, are as follows :-

Yorkshire: Mr. B. Charleson, 5, Kirkstone Drive, Gomersal, Cleckheaton, Yorkshire BD19 4QG.

Eire: Mr. T. McCabe, Cliffoney, Co. Sligo, Eire.

While the decision to join or not to join a Club is, of course, the private choice of the individual, we do strongly recommend that enthusiasts in these areas give the matter some serious thought. Joining a Meccano Club is a good way of getting the maximum enjoyment from the hobby: you meet people with a similar interest; you see the constructional work of others; you have the chance to swap ideas and you can discuss ways of overcoming particular modelling problems of your own. In short, Meccano Clubs are worthwhile phenomena!

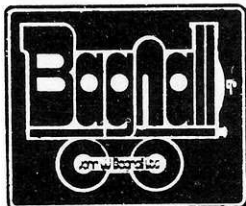

THE BIG NAME IN MECCANO

WE STOCK

MECCANO	SETS	Nos. 1 – 10
MECCANO	SPARES	FULL RANGE
MECCANO	MOTORS	ALL SIZES
MECCANO	CONVERSION SETS	1X – 8X
MECCANO	SPECIAL SETS – Inc. GEARS & ELECTRONICS	
MECCANO	PLASTIC SETS AND CONVERSIONS	

WE SELL

MECCANO	ALL OVER THE WORLD.
MECCANO	BY ACCESS & BARCLAYCARD
MECCANO	BY MAIL ORDER.
MECCANO	TO SCHOOL AND INDUSTRY.

John W Bagnall Ltd
18 Salter Street
Stafford Tel 3420

P.&P. FREE OVER £5 (U.K. Only). SHOP CLOSED ALL DAY WEDNESDAY. PUBLIC CAR PARK AT REAR OF SHOP.

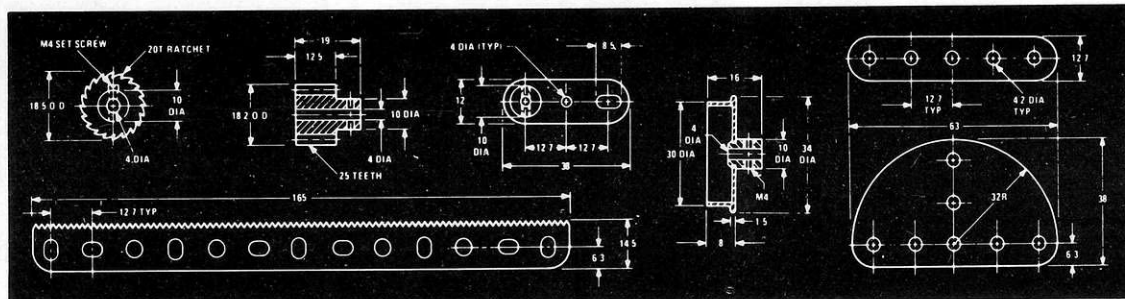

Add a new dimension to **MECCANO**®

Our brand new Meccano catalog features the complete line of standard mechanical parts with detailed dimensions and specifications.

The catalog is a must for creators of original Meccano models and for those who are using Meccano components in other areas, such as the construction of industrial and scientific prototypes, educational models, and for building that "better mouse trap".

To get your copy of the fully-dimensioned Meccano parts catalog, send 30¢ ppd. (for airmail outside the U.S., \$1.00 ppd.) to STOCK MODEL PARTS, 54 South Denton Avenue, New Hyde Park, New York 11040.

Also Available: A new, comprehensive handbook of metric small drive components. The handbook features hundreds of off-the-shelf components, such as gears, shafts, bearings, couplings, pulleys, linkages, etc., plus an extensive technical reference section for working with metrics. Send 95¢ ppd. (for airmail outside the U.S., \$1.95 ppd.) to Stock Model Parts.

Exclusive U.S. distributors of customized kits and industrial products for MECCANO

**STOCK
MODEL
PARTS**
 Division of Designatronics

HOBBIES

for everything the
model maker requires

There's no doubt about it. For model railway and Meccano enthusiasts, a visit to our showroom is an exciting event. Full range of Meccano spare parts always in stock

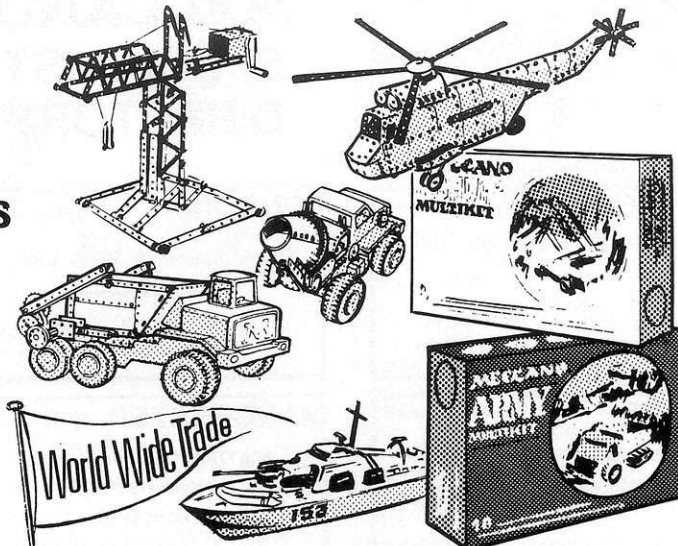

Liverpool's leading model and toy store

Lucas's

HOBBIES

7/9 Tarleton St. Liverpool L1 1DS
(off Church St.) 051-709 7562



DO YOU READ
THE
JUNIOR **MECCANO** ENGINEER
?

The "JME" is aimed at the younger enthusiast but is guaranteed not to harm adult readers!

In the March Edition:-

How Electricity and Magnetism works
Using Gears

Electrikits Parts that were planned but not marketed

A New Front-Wheel Drive Unit
Plus lots more

The "JME" is published quarterly.

March Edition (10p. + 4p. postage) now on sale
(Back Numbers:- No. 1 5p.; No. 2 10p. + postage).

Available from:

MW MODELS, 165, Reading Road, Henley-on-Thames,
Oxon, RG9 1DP, England.

THE PRESENT OF A LIFETIME...

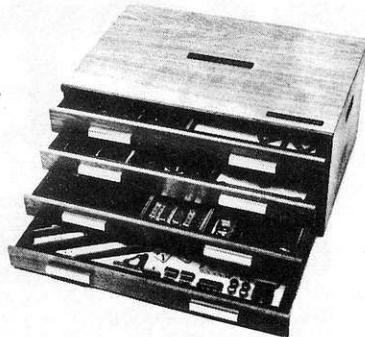

...FOR A LIFETIME!

MECCANO No. 10 OUTFIT
in FOUR DRAWER
OAK FINISH CABINET £135.

Sent anywhere in U.K. CARRIAGE FREE (VATax
free, but sea or freight extra. to overseas).

M.W. MODELS

165, Reading Road, Henley-on-Thames, Oxon, RG9
1DP. Tel: (04912) 3342.

Open Monday to Saturday, early closing Wednesday.

MECCANO
Magazine

52

HENLEY (049 12) 3342
M. W. MODELS
"EVERYTHING MECCANO"
165 Reading Road,
HENLEY-ON-THAMES
Oxon RG9 1DP.
Retail and world wide mail order

HOLBORN 01-405 6285
BEATTIES OF LONDON LTD.
112 High Holborn,
LONDON WC1
For the COMPLETE Range
of Meccano Sets & SPARES.

LEEDS 0532 28611
BEATTIES OF LONDON LTD.
16/18 King Charles Street,
LEEDS 1
For the COMPLETE Range
of Meccano Sets & SPARES.

LONDON 01 734 1846
JEREMY
16 Princes Arcade,
Jermyn Street, London S.W.1
MECCANO specialist in sets, accessories
and spare parts.

MECCANO SPECIALIST DIRECTORY

LONDON Tel: 01-959 2877
H. A. BLUNT & SONS LTD.,
133, The Broadway,
Mill Hill,
LONDON N.W.7 4RN

MANCHESTER 061-834 0229
BEATTIES OF LONDON LTD.
14 Spring Gardens,
MANCHESTER 2
For the COMPLETE Range
of Meccano Sets & SPARES.

PORTHMADOG 2802
SIOP MADOC
41 High Street, Porthmadog,
Caerns.
MECCANO
and OO/HO Model Railway
specialists.

SOUTHGATE 01-886 4268
BEATTIES OF LONDON LTD.
10 The Broadway,
Southgate,
LONDON N14
MAIL ORDERS TO SOUTHGATE
For the COMPLETE Range
of Meccano Sets & SPARES.

WELWYN 26884
H. A. BLUNT
& SONS LTD.
38 FRETHERNE ROAD,
WELWYN GARDEN CITY, HERTS.
Complete range of model aircraft, engines
and accessories, boats, cars and railways.

NEW ZEALAND
BUNKERS LTD.,
P.O. BOX 58
HASTINGS.
Mail orders from all countries welcomed

WEST AUSTRALIA
JACK STANBRIDGE'S
"Hobbyshop",
19 Guildford Road, (at subway),
Mount Lawley, (Perth),
Western Australia.
Full range MECCANO Sets.
Spare Parts available.

BEATTIES

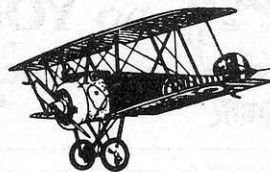
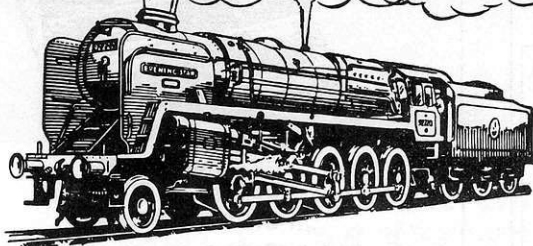

England's Leading Model Shops



BRANCHES:

10, The Broadway Southgate N.14
112, High Holborn London W.C.1
14, Spring Gardens Manchester 2
18, King Charles Street Leeds 1
363, Lewisham High Street London S.E.13

SEE THE COMPLETE RANGE OF MECCANO SPARE PARTS AND SETS AT ANY
BEATTIE SHOP ALL THE YEAR ROUND.

W.R.I. PARTS

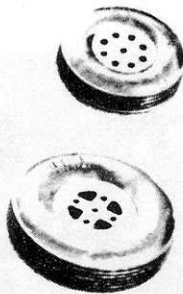
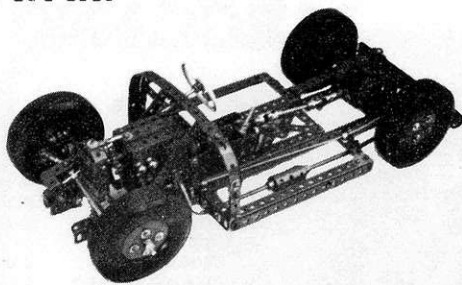

Increase the scope of your Meccano Modelling activities by the use of W.R.I. tyres and Replica Obsolete Meccano Parts.

- | | |
|------------------------------------|-----------------------------------|
| P/N 142m, 4" diam. | P/N 142s, 3" diam. |
| Tyre \$1.25 ea. | Tyre 80¢ ea. |
| P/N 57a, Scientific Hook . 25¢ ea. | P/N 106a, Sand Roller. \$2.00 ea. |
| P/N 119, Channel | P/N 127, Simple Bell |
| Segment \$1.00 ea. | Crank 30¢ ea. |
| P/N 156, Pointer 75¢ ea. | P/N 174, Grease Cup. 60¢ ea. |

All prices in Australian Currency, Postage extra.

Obtainable from certain specialized Meccano Spare Parts stockists or direct from W. R. Inglis, 219 Blackburn Road, South Blackburn, Victoria, 3130, Australia.

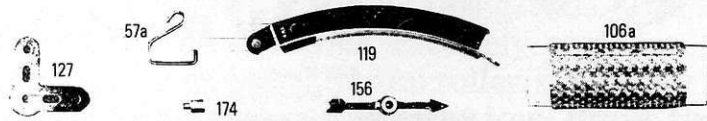

CLASSIFIED ADVERTISEMENTS

Rates: Private, 2p. per word; Trade, 3p. per word. Please send advertisements to: Meccano Magazine Quarterly, Binns Road, Liverpool | L13 1DA.

FOR SALE: Meccano Magazines 1937 bound \$15.00. One battery charger, charges battery 2, 4, 6 volts with knob control for setting volt charger \$12.00. One 1930 M.M. and six 1932 MM. All items are in good condition. Mr. Emile Amirault, Box 201, Edam, Sask. Canada, SOM OVO.

WANTED: Obsolete Dinky and Corgi Toys lorries, trucks, tractors, buses, coaches, trailers, caravans, circus models. Any condition. Also old catalogues. Your price paid. Tor Olaisen, Storgaten 53, 2000 Lillestrom Norway.

DINKY AIRCRAFT WANTED: Good prices paid for pre-war types in mint condition. Specially wanted - 60F and 66F Autogiros; 66 series camouflaged models Atalanta and Monospar. Also presentation Boxes 64, 65, 66, 68, (with or without contents) and other original boxes. Any Dinky items made under licence in India also required. Full details to Alan Dimmock, 2 Wynter Road, Bitterne, Southampton, SO2 5NY.

WANTED: Meccano parts; must be in very good condition; also Meccano Magazines. Wilkie, 58A Craiglockhart, Gardens, Edinburgh, EH14 1LY.

KENT SNYDER/GOODTHINGS, 437 Cambridge Avenue, (at Mimosa Lane), Palo Alto, Calif. 94306 (Tel: (415) 328 81550) solicits the patronage of Meccano enthusiasts of the Bay Area.

WANTED: Dinky 30/36/38/39 Series. Models Racing/Record - Crescent. Please write including price to Roberto Bertolini - V. Garibaldi 57, 10123 Torino, Italy.

WANTED: 1929 Meccano Steam Engine. William Fisher, 619 Centre Street, Ashland, Pa., 17921, U.S.A.

FOR SALE: Electrical Set, early 1920. Enclose two International Reply coupons for airmail letter giving details. Kowal, 6615 South Bell, Chicago, Ill. 60636, U.S.A.

EVERYTHING MECCANO®

WORLD-WIDE MAIL ORDER SETS - PARTS - LITERATURE

NEW SPECIAL 1974 POST FREE SERVICE (U.K. Only)

Any Meccano Set; Multikit, or order for Standard Spare Parts 1-235F in Pack Quantities.

Sent POST FREE (U.K. Only)

Special Order Form Available SORRY! all other orders and overseas orders - POSTAGE EXTRA. Please include a good margin with your order - all surpluses credited or refunded.

WRI TYRES now available.

- | | | |
|------|------|------|
| 142m | each | 1.09 |
| 142s | each | 0.76 |

ARGENTINE MECCANO PARTS

Sample selection from full available list:

CURRENT (LIVERPOOL) FINISH	E	P
11b Double Angle Strip 1" x 1/2"	05	
26d Pinion 15 teeth 1/2" face 7/16" dia	30	
A30a Bevel Gear 16t. 1/2" D.		1 30
A30c Bevel Gear 48t. 1 1/2" D. (machined)	1 each	20
54a Flat Sector Plate 4 1/2" long	20	
71 Flat Plate 3 1/2" x 2 1/2"	10	
74a Flat Plate 2 1/2" x 1 1/2"	08	
A126 Slotted Trunnion	07	
A126a Slotted Flat Trunnion	06	
A211e Helical Gear 14t. 1/2" D		1 20
A211b Helical Gear 35t. 1 1/2" D (A211b Drilled)	1 each	20
RED/GREEN FINISH		
G1a Perforated Strip 9 1/2"	09	
G1b Perforated Strip 7 1/2"	08	
G6 Perforated Strip 2"	05	
G6a Perforated Strip 1 1/2"	05	
G7 Angle Girder 24 1/2"	34	
G8 Angle Girder 12 1/2"	16	
G8a Angle Girder 9 1/2"	13	
G8b Angle Girder 7 1/2"	11	
G8c Angle Girder 5 1/2"	09	
G8d Angle Girder 4 1/2"	09	
G8e Angle Girder 3 1/2"	08	
G8f Angle Girder 3"	06	
G8g Angle Girder 2 1/2"	06	
G8h Angle Girder 2"	06	
G8i Angle Girder 1 1/2"	06	
G8j Angle Girder 1"	06	
G11a Double Bracket 1" x 1/2"	05	
G11b Double Angle Strip 1" x 1/2"	05	
G12b Angle Bracket 1" x 1/2"	05	
R53a Flat Plate 4 1/2" x 2 1/2"	10	
R54a Flat Sector Plate 4 1/2" long	20	
G62 Crank	15	

LATEST MECCANOMAN'S CLUB SUPERMODEL LEAFLETS.

- | | | |
|---------|--------------------|-----|
| No. 45. | Fairground Skyride | 60p |
| No. 46. | Grandfather Clock | 75p |

THE MECCANOMAN'S JOURNAL (quarterly)

No. 35 April 1974. 34p.

For April Newsletter and lists of MECCANO SETS, Parts, Replica Parts and Literature Send:- Home - Large 4p S.A.E.

Overseas - 4 Reply Coupons. Overseas orders sent U.K. V.A. Tax free

M.W. MODELS, 165, Reading Road, Henley-on-Thames, Oxon, RG9 1DP, England. Tel: Henley (04912) 3342.

EVERYTHING

MECCANO

STANDARD SETS

POCKET SET	0.50
No. 1 SET	1.65
No. 2 SET	2.65
No. 3 SET	3.65
No. 4 SET	4.85
No. 5 SET	7.25
No. 6 SET	9.75
No. 7 SET	12.15
No. 8 SET	14.95
No. 9 SET	31.65
No. 10 SET	135.00

CONVERSION SETS

1x	1.05
2x	1.15
3x	1.55
4x	2.85
5x	3.00
6x	2.85
7x	4.05
8x	11.05

ANY SET SENT

POST FREE

(V.A. Tax free, but postage extra, to Overseas)



SPECIAL SETS

No. 3M	5.95
No. 4M	8.15
No. 4EL	13.70
No. 5ME	18.30
GEARS SET	2.75
ELECTRONICS CONTROL	5.85
MECHANISMS SET	4.65
SUPER TOOL SET	1.60

CLOCK KITS

No. 1 CLOCK KIT	4.35
No. 2 CLOCK KIT	8.80

MULTIKIT

HIGHWAY MULTIKIT	5.25
ARMY MULTIKIT	5.95
SUPER HIGHWAY	7.75

M.W.models

165 Reading Road, Henley-on-Thames,
Oxon, RG9 1DP. Tel: (04912) 3342

Open Monday to Saturday, early closing Wednesday

MECCANO® MULTIKIT®

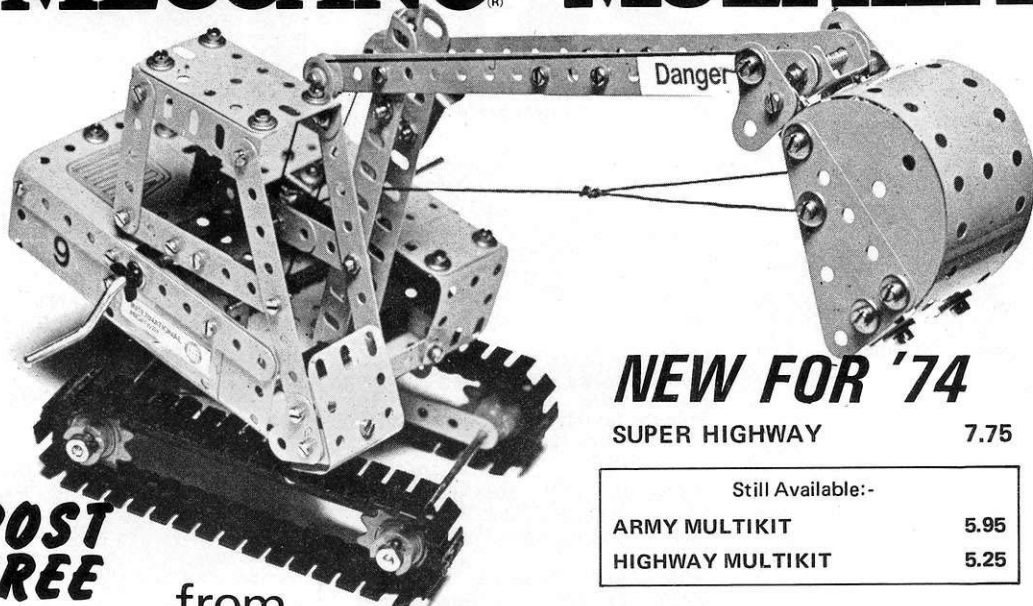

NEW FOR '74

SUPER HIGHWAY 7.75

Still Available:-

ARMY MULTIKIT	5.95
HIGHWAY MULTIKIT	5.25

POST FREE

from

(V.A. Tax Free,
but postage extra to Overseas)

M.W.models

165, Reading Road, Henley-on-Thames
Oxon, RG9 1DP. Tel: (04912) 3342

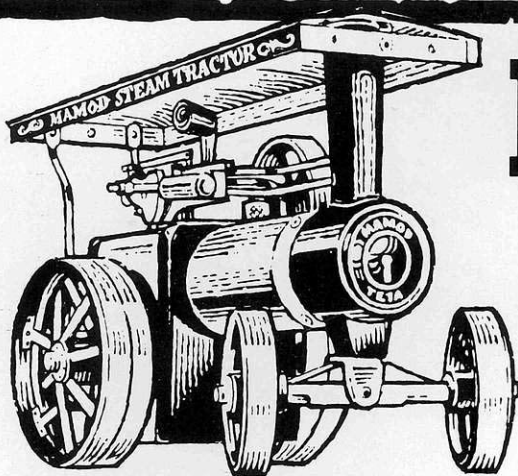

For boys of all ages

For kids, dads and grandads, a Mamod working steam model is something to get really steamed up about all the year round. Precisely engineered traction engine, steam wagon, steam roller, stationary steam engines and accessories, wagons to tow. Prices from £2.82 (tractor £8.95, steam roller £8.70). From all leading toy shops.

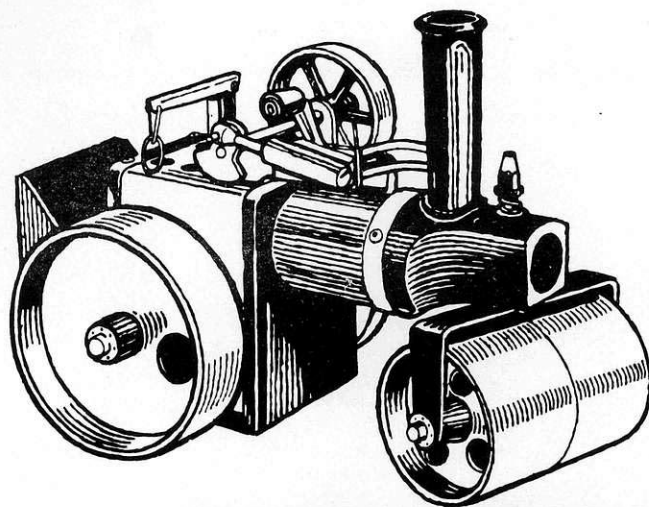

Malins (Engineers) Ltd.,
Brierley Hill,
Staffordshire.

Mamod

**U.S.
READERS**

**JUST 3 OF THE LATEST
Dinky
TOYS®**

**MULTI-ROLE
COMBAT
AIRCRAFT**

MODEL No. 729



*WITH LINKED
SWING-WING ACTION AND
RETRACTABLE UNDERCARRIAGE*

**BELL
POLICE
HELICOPTER**

Model 732



- Freely rotating rotor blade and rudder blade
- Clear perspex cockpit

211 mm long

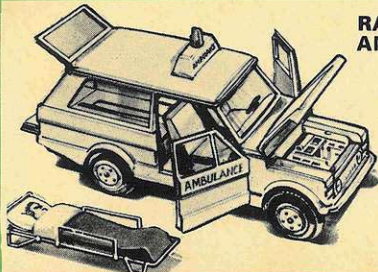

**RANGE ROVER
AMBULANCE**

Model 268

- Opening doors and bonnet
- Folding seats
- Opening tailgate
- Casualty on stretcher

109 mm long

**GREAT
NEW
MECCANO
MULTIKIT**



**MECCANO
HIGHWAY
MULTIKIT**

8 DIFFERENT MODELS FOR YOU TO BUILD
IN THE NEW EXCITING COLOUR PHOTO STEP-BY-STEP INSTRUCTION BOOK



**MECCANO
ARMY
MULTIKIT**

10 DIFFERENT MODELS FOR YOU TO BUILD
IN THE NEW EXCITING COLOUR PHOTO STEP-BY-STEP INSTRUCTION BOOK

MECCANO HIGHWAY MULTIKIT

Load up and hit the road! Each Highway Multikit makes 8 great commercial vehicles. Interesting and easy to build – great fun to play with.

MECCANO ARMY MULTIKIT

One kit that makes 10 fantastic army vehicles. Great fun to build – great fun to play with. Kids never get bored with Meccano Multikit – there's so much to do with them!

AVA INTERNATIONAL, INC.

FOR INFORMATION CONTACT:

**6500 DEPOT DRIVE
P.O. BOX 7611
WACO, TEXAS 76710
817-772-4530**