

Snippet. 'New' System: MECÂNICA RECREATIVA

Two sets of this name were offered in one lot on the Argentine Ebay but the words are Portuguese (meaning Mechanical



FIG.1

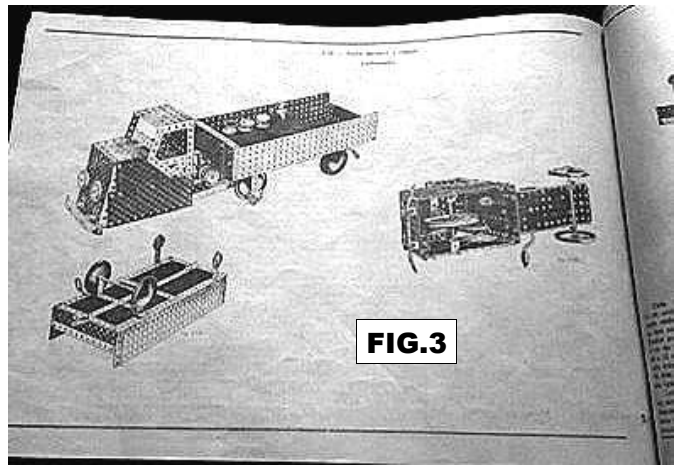

FIG.3

Recreation) and the maker was given as Fabrica Bonsucesso of Rio de Janeiro.

One box is shown top left; the second is slightly smaller with a similar label that almost covers the lid. The parts from the two, or what remains of them, were mixed together and most types are shown far left with the remainder inset. They are obviously a copy of MECCANO (even to the brass grip on the Crank Handle) though there is no confirmation that the hole pitch, thread, etc are identical.



FIG.2

One page (above) of the manual was shown and the photos on it are those of Liverpool's 6.13, Mechanical Horse and Trailer, from the years 1937-47, though without the original's 4th view, notes & list of parts. The next model in the MECCANO manual is Sydney Harbour Bridge and one can just see the tip of its left end on the next page.

Given the models in the manual and the red/green colour scheme of the parts, the system most likely appeared after rather than before WW2.

OSN 44/1351

MECÂNICA RECREATIVA: S1

A STATO-BAU Nr.49 Outfit The Contents of Set 49 were given in 37/1121 and illustrations of the various parts were shown in 40/1209-10; now Jürgen Kahlfeldt has kindly sent details of an actual set.

The Box It measures 527*364*23mm, and is in the same style as the Nr.48 in OSN 40 but with partitioning that gives 5 narrow compartments along the bottom, 2

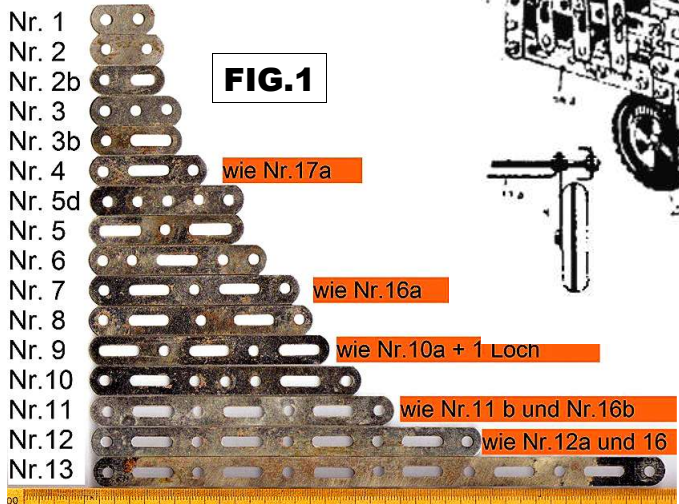

FIG.1

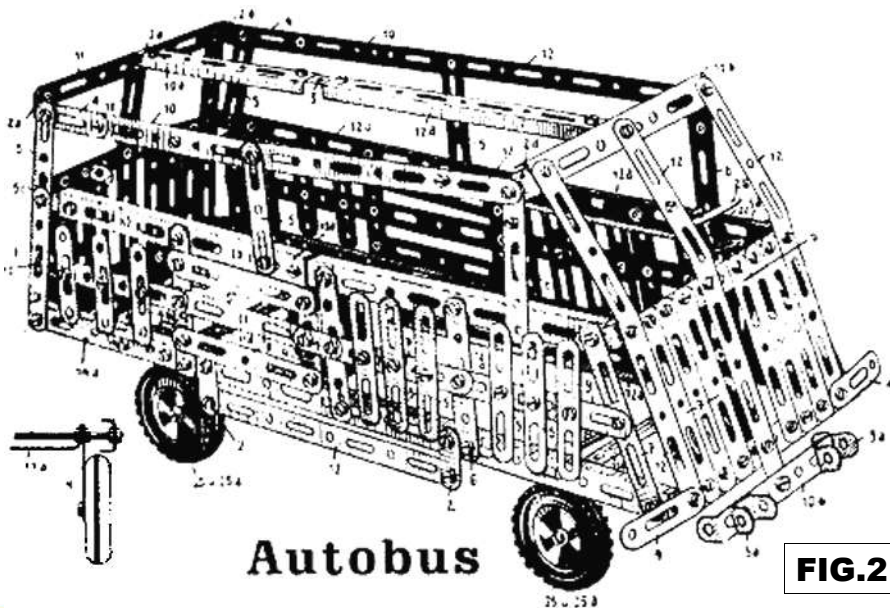

FIG.2

along the left, and 4 along the right side. The N&B etc are in 3 of the round, blue-lidded boxes, 2 as in the Nr.48 but one smaller, about 5cm Ø.

The Parts Their piercing is not always obvious from the illustrations and Jürgen sent a photo (Fig.1) to clarify matters.

OSN 44/1351

STATO-BAU: S6